



Centuri

MAGNUM-D

Jayhawk

This model is an accurate 1/5 scale model of the Navy version of the AQM-37A target drone. The AQM-37A is used in all branches of the service and each gives it its own "working name". The Navy has called theirs the Jayhawk.

Centuri's designers chose the materials used in this kit for two reasons: by using paper and balsa instead of molded plastic for detailing, it provides a challenge for the modeler and holds down the purchase price of the kit.

The airframe and markings are very accurate on the entire model except for some subtle differences in the nose cone. The AQM-37A when finished according to the instructions is an excellent model for scale competition. The scale data booklet included with the kit gives accurate detailed information about the real AQM-37A.



CONTENTS

Exploded View.....	4,5
Assembly.....	2,3,6,7
Decals.....	8
Recovery System.....	4
Flying Instructions.....	4

CENTURI Engineering Co., Inc., P.O. Box 1988, Phoenix, AZ 85001



The Centuri JAYHAWK was developed with the help of two leading NAR rocketeers: Chris Pocock (left) and Doug Frost (right). Chris and Doug are widely regarded as the country's most expert Jayhawk scale modelers, having won many regional and national rocketry awards. Their research, scale data and field-testing helped our engineers make this great kit even better.

MODEL ROCKETEER'S SAFETY CODE

CONSTRUCTION

My model rockets will be made of only lightweight materials such as paper, wood, plastic, and thin metallic foils, with the exception of payloads and engine holders made of wirelike material.

ENGINES

I will use only pre-loaded factory made model rocket engines in the manner recommended by the manufacturer. I will not change in any way nor attempt to reload these engines.

RECOVERY

I will always use a recovery system in my model rockets that will return them safely to the ground so that they may be flown again.

WEIGHT LIMITS

My model rocket will weigh no more than 453 grams (16 oz.) at liftoff, and the engines will contain no more than 113 grams (4 oz.) of propellant, as prescribed by Federal Regulations.

STABILITY

I will check the stability of my model rockets before their first flight except when launching models of already proven stability.

LAUNCHING SYSTEM

The system I use to launch my rockets will be remotely controlled and electrically operated, and will contain a switch that will return to "off" when released. I will remain at least 15 feet away from any rocket that is being launched.

LAUNCH SAFETY

I will not let anyone approach a model rocket on a launcher until I have made sure that either the safety interlock key has been removed or the battery has been disconnected from my launcher.

FLYING CONDITIONS

I will not launch my model rocket in high winds, near buildings, power lines, tall trees, low flying aircraft or under any conditions which might be dangerous to people or property.

LAUNCH AREA

My model rockets will always be launched from a cleared area, free of any easy to burn materials, and I will only use non-flammable recovery wadding in my rockets.

BLAST DEFLECTOR

My launcher will have a blast deflector device to prevent the engine exhaust from hitting the ground directly.

LAUNCH ROD

To prevent accidental eye injury I will always place the launcher so the end of the rod is above eye level or cap the end of the rod with my hand when approaching it. I will never place my head or body over the launching rod. When my launcher is not in use I will always store it so that the launch rod is not in an upright position.

POWER LINES

I will never attempt to recover my rocket from a power line or other dangerous places.

LAUNCH TARGETS AND ANGLE

I will not launch rockets so their flight path will carry them against targets on the ground, and will never use an explosive warhead nor a payload that is intended to be flammable. My launching device will always be pointed within 30 degrees of vertical.

PRE-LAUNCH TEST

When conducting research activities with unproven designs or methods, I will, when possible, determine their reliability through pre-launch tests. I will conduct launchings of unproven designs in complete isolation from persons not participating in the actual launching.

HOW IT WORKS

Your Jayhawk model rocket is designed to fly in the same manner as other model rocket kits. The electrically ignited engine provides the power to boost the rocket to peak altitude. The rocket is guided off the launcher by two launch lugs. At peak altitude the engine's ejection charge is activated to eject the parachutes for recovery. The Jayhawk returns to Earth ready for another flight.

WHAT IT TAKES TO FLY

You will need engines, igniters, an electrical launch system and a 3/16" DIAMETER LAUNCH ROD to launch your Jayhawk. These supplies are not included in individual rocket kits. Engines, igniters, and launch systems are included in every Centuri Starter Set or Rocket Outfit. A 3/16" launch rod is available from your local Centuri retailer or direct from Centuri.



We recommend the use of Magnum D engines; each package includes the famous "Sure-Shot II" igniters, acclaimed as the world's most reliable model rocket igniter.

The popular Centuri Power Tower launch stand and Powr-Control launch system are ideal for launching your Jayhawk. In addition, they can be used to launch any other kit Centuri makes.

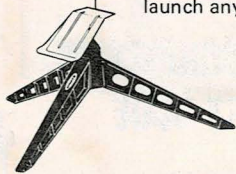

Always use standard remote-control electrical ignition and follow the engine recommendations. Be sure to comply with any laws that may apply in your area, for the good of Model Rocketry and your own enjoyment.

RIGHT MATERIALS FOR THE JOB

Different model rocket kits are made out of a variety of materials, depending on the needs of each kit. The chart below explains why this particular kit is designed using certain materials.

PART	REQUIREMENTS	MATERIAL
Body & Fins	<ul style="list-style-type: none"> • Light Weight • Strength 	Balsa & Paper
Nose Cone	<ul style="list-style-type: none"> • Strength 	Plastic

TOOLS YOU WILL NEED

In addition to the parts supplied, you will need the following tools to assemble and finish this kit.



Wire Cutters

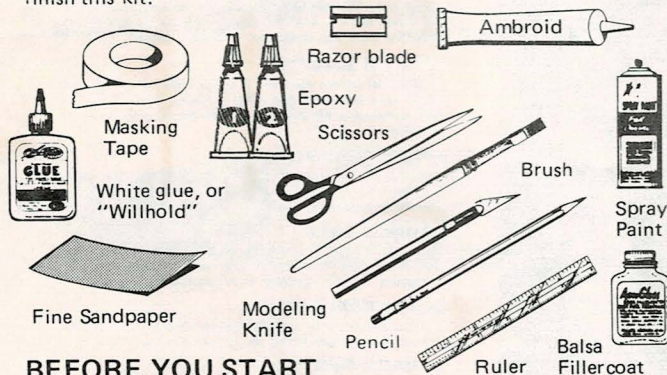

BEFORE YOU START

If you are new to model rocketry, here are some general tips to get you off to a good start.

- Choose a practical assembly area: well lighted, big enough to work in, and out of the way of relatives or pets who might accidentally mess up your work.
- Cover your worktable with plywood or heavy cardboard to protect the table from glue, paint, cuts, etc.
- Remove the entire contents of your kit package carefully to avoid losing or damaging small parts. Lay them out neatly and identify each by referring to the "exploded view" drawing on this instruction.
- NOTE: Sometimes certain parts are packed INSIDE of other parts, such as tape discs inside parachutes, decals or couplers inside body tubes, etc.

ASSEMBLY INSTRUCTIONS

You **MUST** follow these instructions for satisfactory flights. The shape and placement of the model's parts has been carefully engineered for safe flights. **DO NOT** try to change the design, "customize" it, or leave off any parts.

- 1 To assemble the paper boat-tail (shiny side out), pre-curl the paper by gently pulling up from under a ruler on a clean, flat surface. Note the little tick marks on one end for aligning overlap. Form into a cone and apply glue opposite the overlap area. Line up the edge of the paper with the tick marks exactly and press together on a flat surface. Wipe away excess glue.

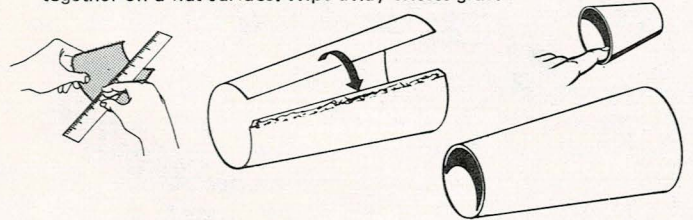

- 2 Locate the clay weight, 1/8 inch dowel and the nose cone. Form clay into thin "worms" and insert one into the open end of the nose cone. Use only one end of the wooden dowel to tamp the clay into the front of the nose cone as far as possible. Tamp all the clay "worms" into the nose cone in this manner.



- 3 Stand boat-tail on end with smaller opening facing down. Drop the smaller die-cut ring from thick die-cut sheet into boat-tail. Tamp gently into place so ring is flush with edge of boat-tail. **THIS IS VERY IMPORTANT!**—Make sure tick mark is lined up with seam on boat-tail. After you are sure of proper alignment, apply a fillet of glue along inside seam of ring/boat-tail.

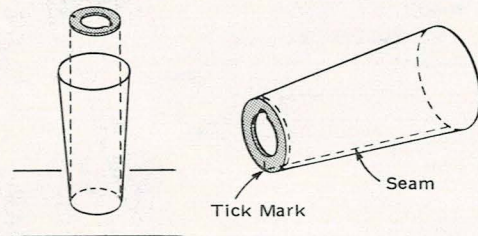

- 4 Locate 2 of the 3 identical centering rings from the thick die-cut sheet and one of the tube couplers. Glue one ring to the end of the coupler making sure it is flush all the way around. Repeat with 2nd ring on the other end.

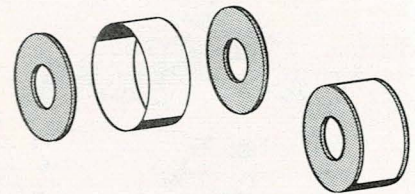

- 5 Place a bead of glue on the inside of the stuffer tube about 2" from the end of the tube. Insert thrust ring into end of tube. Using the engine spacing tube push the thrust ring into the tube until 1/4" of spacing tube remains showing. Remove spacing tube quickly before glue sets.

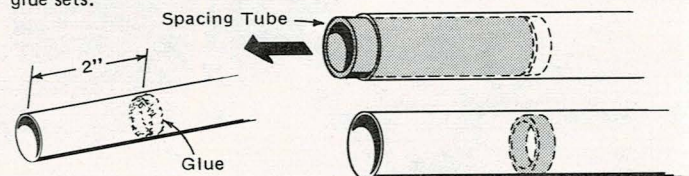

- 6 Mark stuffer tube 2-1/2" from end. With a sharp hobby knife make a 1/8" wide slit. Bend the engine lock slightly and insert one end into slit as shown. Lift engine lock slightly and run a bead of glue underneath it. Lay lock back down into glue and wrap a piece of masking tape around entire tube as shown.

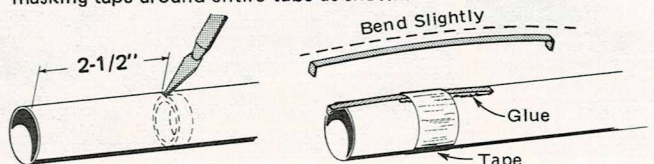

- 7** Slide boat-tail onto stuffer tube from forward end. Slide tube coupler assembly onto stuffer tube and test fit into the boat-tail. Slide back, place a ring of glue just inside edge of boat-tail and slide tube coupler back into place. Place boat-tail on edge of desk top with engine lock overlapping. Slide stuffer tube until end of tube is flush with rear of boat-tail. Apply ring of glue around boat-tail/stuffer tube joint.

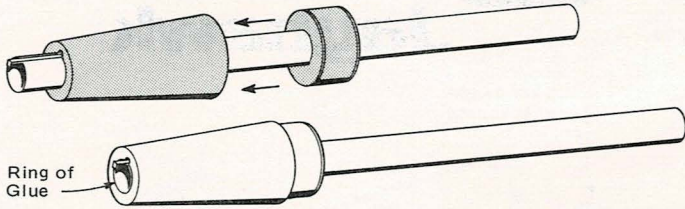

- 8** Glue the 3rd remaining identical ring to tube coupler making sure ring is flush with edge of coupler. Mark coupler 1/2" from edge. Run a line of glue along the inside edge of one of the main body tubes. Carefully insert coupler into tube up to mark. Apply glue line along inside edge of 2nd half of main body tube and join 2 halves together. Roll entire tube along a flat surface to be sure the tube halves are joined straight.

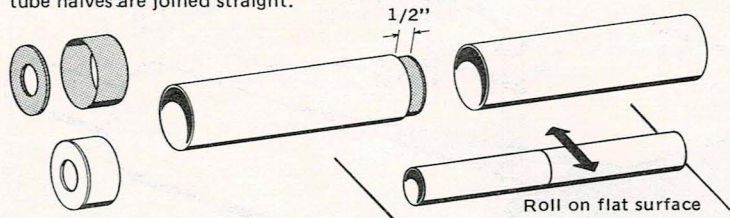

- 9** Stand main body tube on end and place on fin guide. Mark tube at all positions shown. Find a convenient groove or channel such as a door jamb or open drawer. Very carefully extend all marks down entire length of tube making sure they are straight.

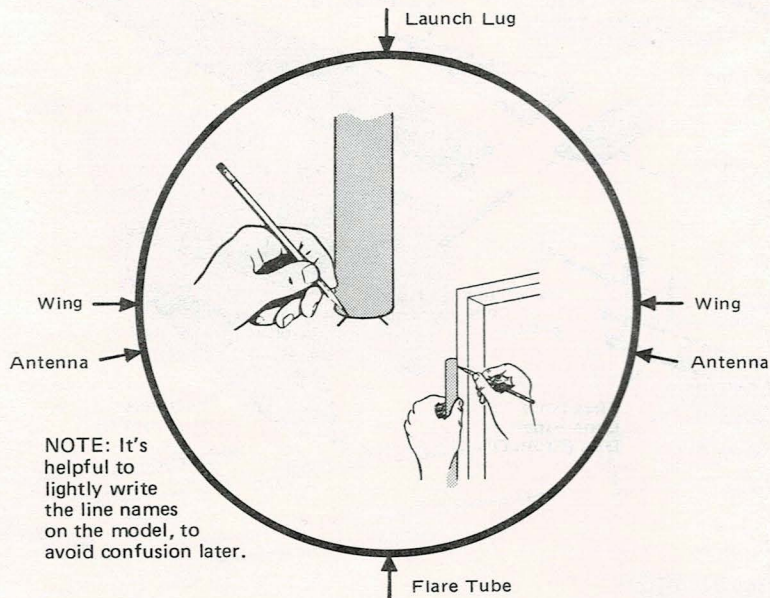

- 10** Test fit boat-tail/stuffer tube assembly into main body tube. Align seam of boat-tail with flare tube line. Remove assembly part way, apply glue along inside edge of main tube and push assembly back in place. Make sure boat-tail seam is aligned with flare tube line.

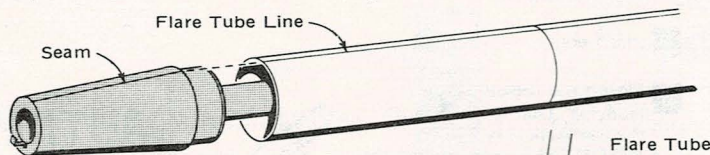

- 11** Remove nose cone shape from flare tube cut-out guide. Tape guide to front end of main body tube making sure forward edge is flush with front of main body tube. Trace along inside of nose cone cut-out with a ball point pen. Remove guide. Using a sharp modeling knife, cut along the lines you've just drawn and remove cut piece.

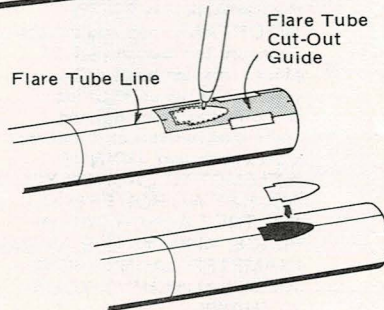

- 12** Carefully remove balsa wing sections from die-cut sheet. Holding identical sections together, sand all edges with a sanding block or on a piece of sandpaper on a flat surface. Lay a piece of waxed paper on a flat surface and glue wing sections together as shown. Repeat this procedure for rudders.

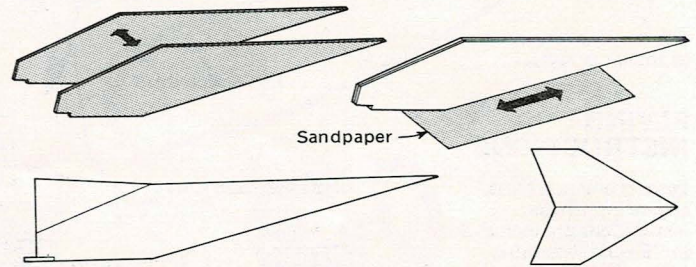

- 13** Remove flare tube inner support pieces from thick die-cut sheet. Glue pieces together as shown.

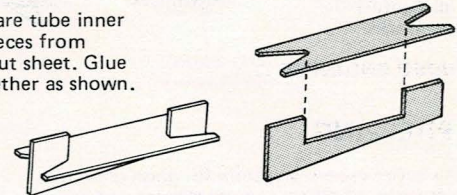

- 14** Remove flare shroud plate from thin die-cut sheet. Apply a thin film of glue on back side (dull) and glue into position on boat-tail using tick marks and boat-tail seam for alignment. Be sure plate is set back 1/4" from rear edge of boat-tail.

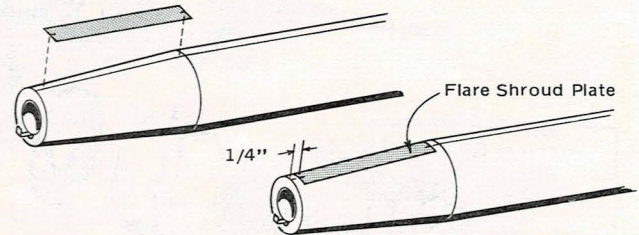

- 15** Stand flare tube on the guide below and place two marks where the arrows indicate. Find a convenient groove or channel such as a door jamb or open drawer. Very carefully extend marks down entire length of flare tube, making sure they are straight on tube. Using a single edge razor blade, carefully make a light scribe down line by pulling razor towards you slowly. Repeat with several light scribes until you cut through tube. DO NOT ATTEMPT TO MAKE CUT IN ONE STROKE. Repeat this procedure along remaining line. You will end up with 2 halves, only one will be used in this kit.

Note: When cutting tube NEVER place hands or fingers in front of path of razor blade.

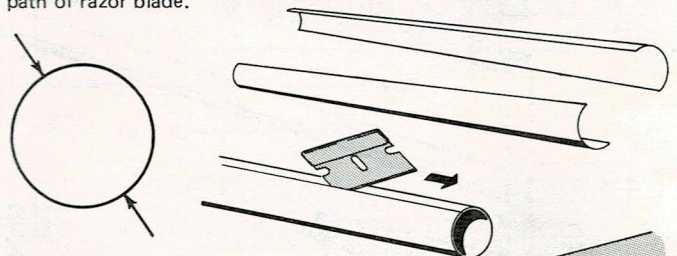

- 16** Glue flare tube inner support piece into one end of flare tube with edge flush with edge of flare tube.

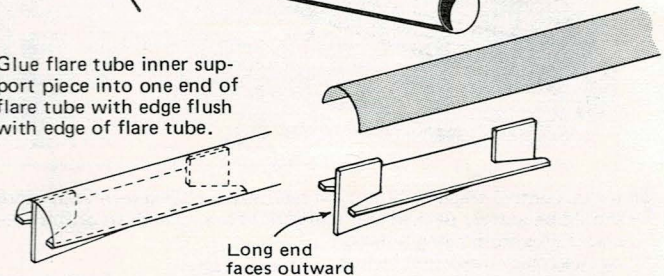

- 17** Locate the flare nose cone paper disc from the thick die-cut sheet. Using epoxy or Ambroid cement, glue flare nose cone paper disc into base of cone as shown. Glue entire nose cone into flare tube.

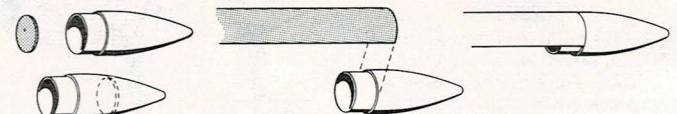

NOTE: ASSEMBLY CONTINUED ON PAGE 6

RIGGING THE RECOVERY SYSTEM

Assemble the two parachute kits enclosed, following the instructions printed right on the chute material. Save the left over shroud line for the next step.

Rig the recovery system as shown at right.

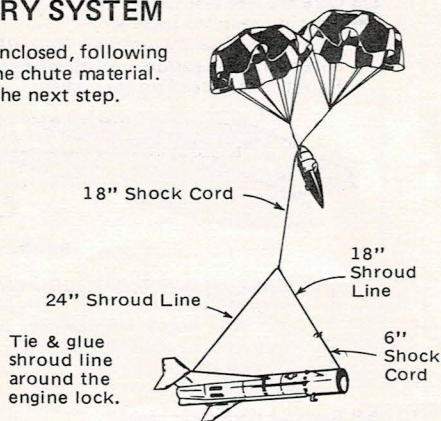

FLYING INSTRUCTIONS

Igniters and complete engine installation instructions are included in "Engine Operating Instructions" which accompany all Centuri Magnum-D engines.

RECOMMENDED ENGINE: D12-3

FLIGHT PREPPING

- 1 Inspect the entire recovery system for good condition before each flight. If recovery system is tangled from last flight, untangle by cutting it apart and then reattach. (Remaining steps below Exploded View).

Exploded

Centuri MAGNUM-D™ Jayhawk

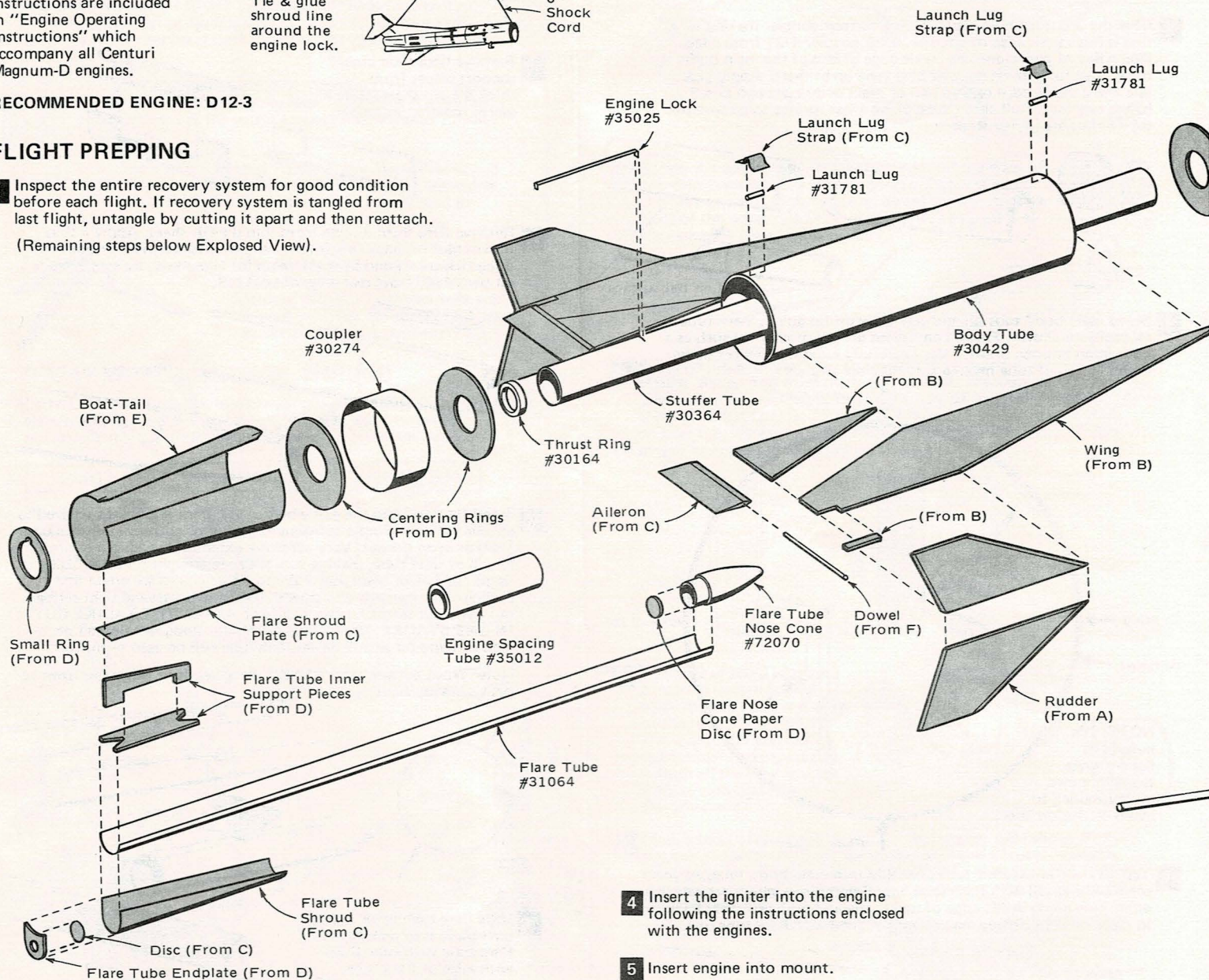

- 2 Insert Centuri crepe or fibre type recovery wadding into your model. This should be loosely packed and you should use enough to protect your parachutes from being burned by the engine's ejection charge. Do not pack too lightly. Use 8 sheets of crepe wadding or a loosely packed 3" ball of fibre.

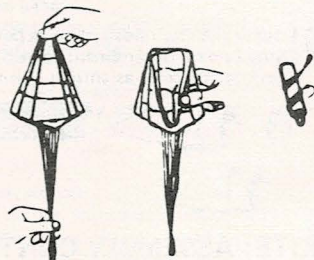

- 3 Fold the parachutes as shown and insert them into the body tube. Place the nose cone in place, making sure the fit of the nose cone is correct. It should fit snugly.

4

- 4 Insert the igniter into the engine following the instructions enclosed with the engines.

- 5 Insert engine into mount.

- 6 Mount the rocket on your launcher. Due to the size of the Jayhawk it is VERY IMPORTANT that you weight or secure the launch pad in place. This can be done by placing a brick on each leg of the launcher or by cutting apart coat hangers and making stakes as shown. DO NOT ATTEMPT TO LAUNCH YOUR ROCKET WITHOUT SECURING THE LAUNCH PAD IN PLACE. ALWAYS USE A 3/16" DIAMETER LAUNCH ROD WHEN LAUNCHING YOUR JAYHAWK.

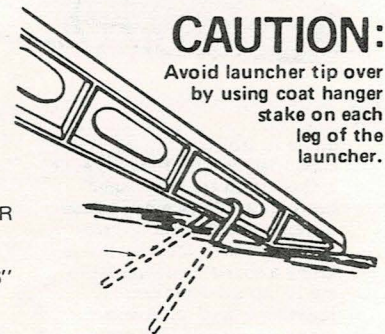

CAUTION:

Avoid launcher tip over by using coat hanger stake on each leg of the launcher.

RIGGING THE RECOVERY SYSTEM

Assemble the two parachute kits enclosed, following the instructions printed right on the chute material. Save the left over shroud line for the next step.

Rig the recovery system as shown at right.

FLYING INSTRUCTIONS

Igniters and complete engine installation instructions are included in "Engine Operating Instructions" which accompany all Centuri Magnum-D engines.

RECOMMENDED ENGINE: D12-3

FLIGHT PREPPING

- 1 Inspect the entire recovery system for good condition before each flight. If recovery system is tangled from last flight, untangle by cutting it apart and then reattach. (Remaining steps below Exploded View).

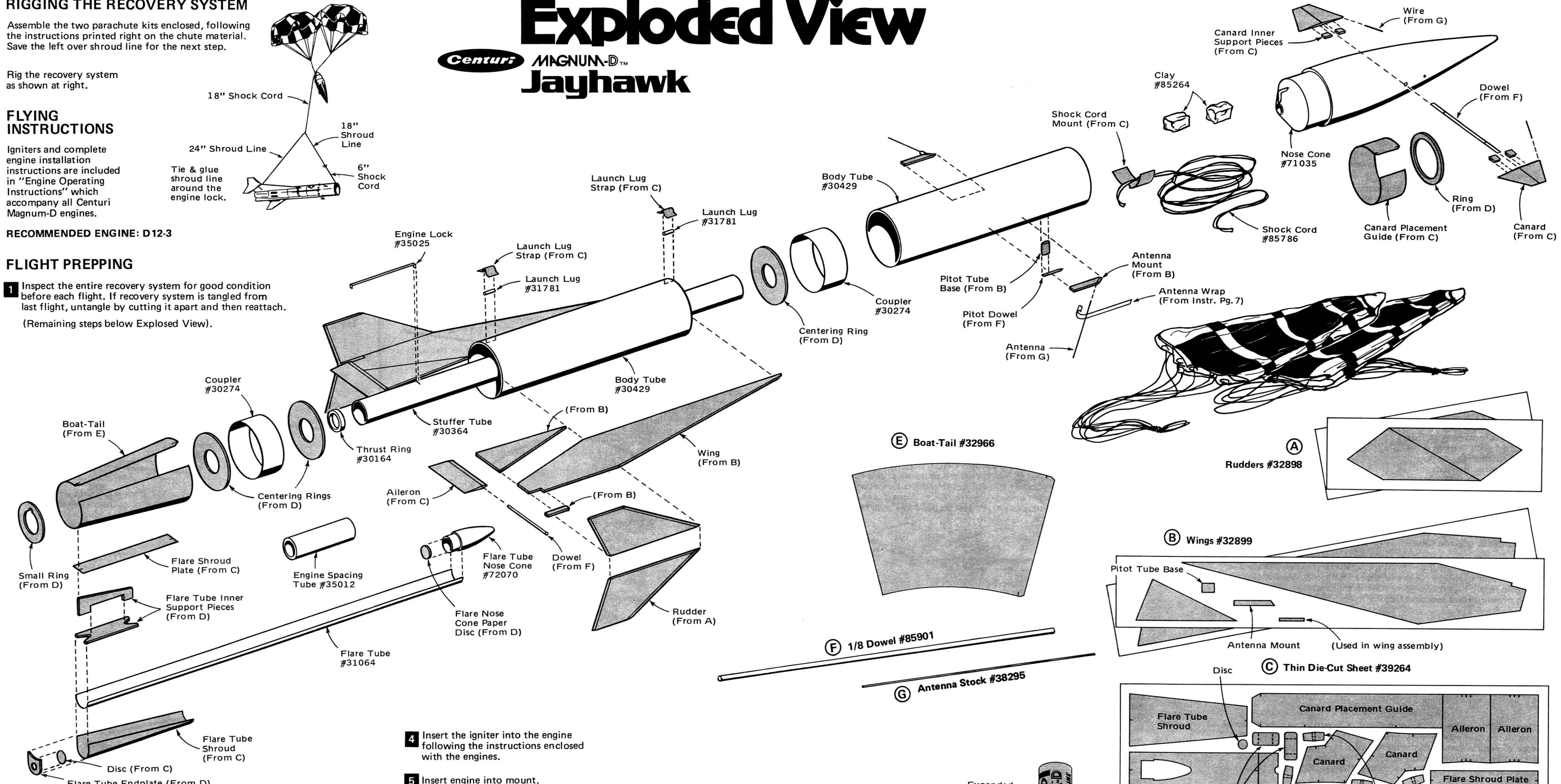

- 2 Insert Centuri crepe or fibre type recovery wadding into your model. This should be loosely packed and you should use enough to protect your parachutes from being burned by the engine's ejection charge. Do not pack too lightly. Use 8 sheets of crepe wadding or a loosely packed 3" ball of fibre.
- 3 Fold the parachutes as shown and insert them into the body tube. Place the nose cone in place, making sure the fit of the nose cone is correct. It should fit snugly.

- 4 Insert the igniter into the engine following the instructions enclosed with the engines.
- 5 Insert engine into mount.
- 6 Mount the rocket on your launcher. Due to the size of the Jayhawk it is VERY IMPORTANT that you weight or secure the launch pad in place. This can be done by placing a brick on each leg of the launcher or by cutting apart coat hangers and making stakes as shown. DO NOT ATTEMPT TO LAUNCH YOUR ROCKET WITHOUT SECURING THE LAUNCH PAD IN PLACE. ALWAYS USE A 3/16" DIAMETER LAUNCH ROD WHEN LAUNCHING YOUR JAYHAWK.

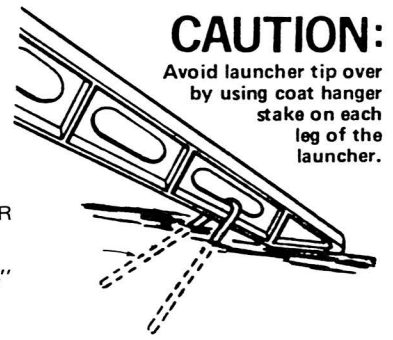

RECOMMENDED LAUNCH SYSTEM:
 #5601 Power Tower Launch Stand
 #5623 Powr-Control Controller
 #5803 Heavy-Duty 3/16" Launch Rod (Rod available by mail order for \$1.75 plus \$1.50 handling). May substitute 3/16" pianowire or welding rod.

Avoid eye injury by capping the exposed tip of the launch rod when not actually launching. Follow the instructions and the Safety Code, and have many happy hours with model Rocketry.

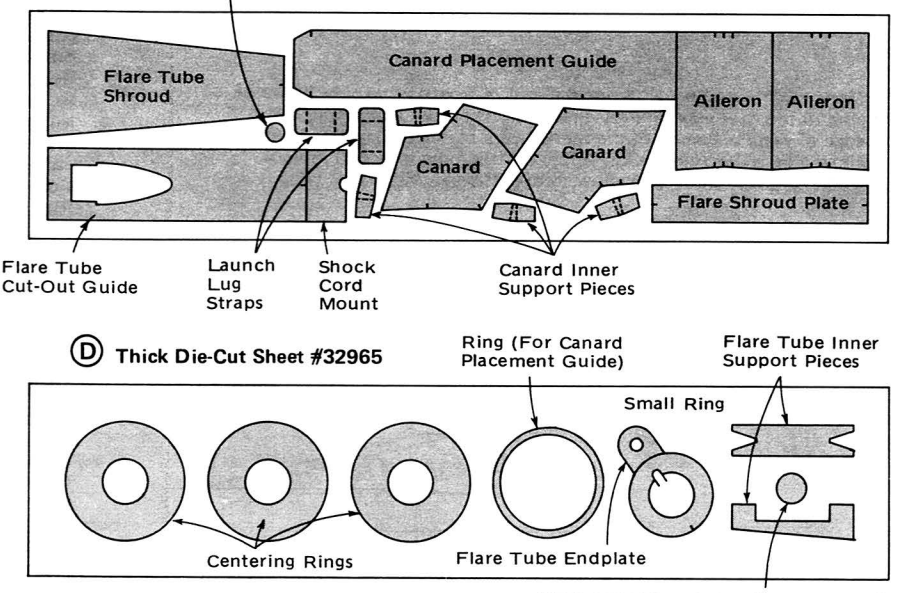
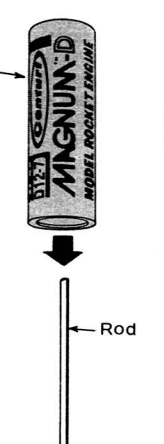

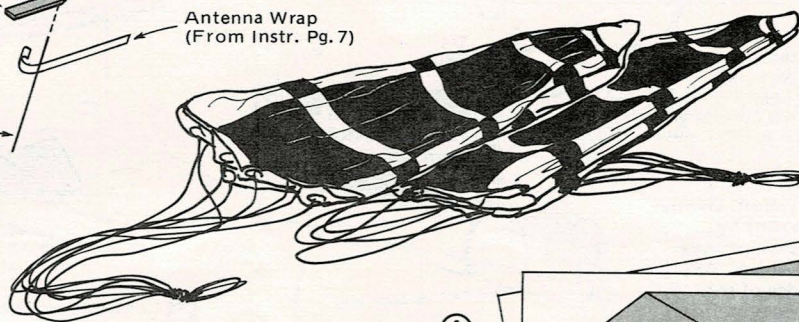
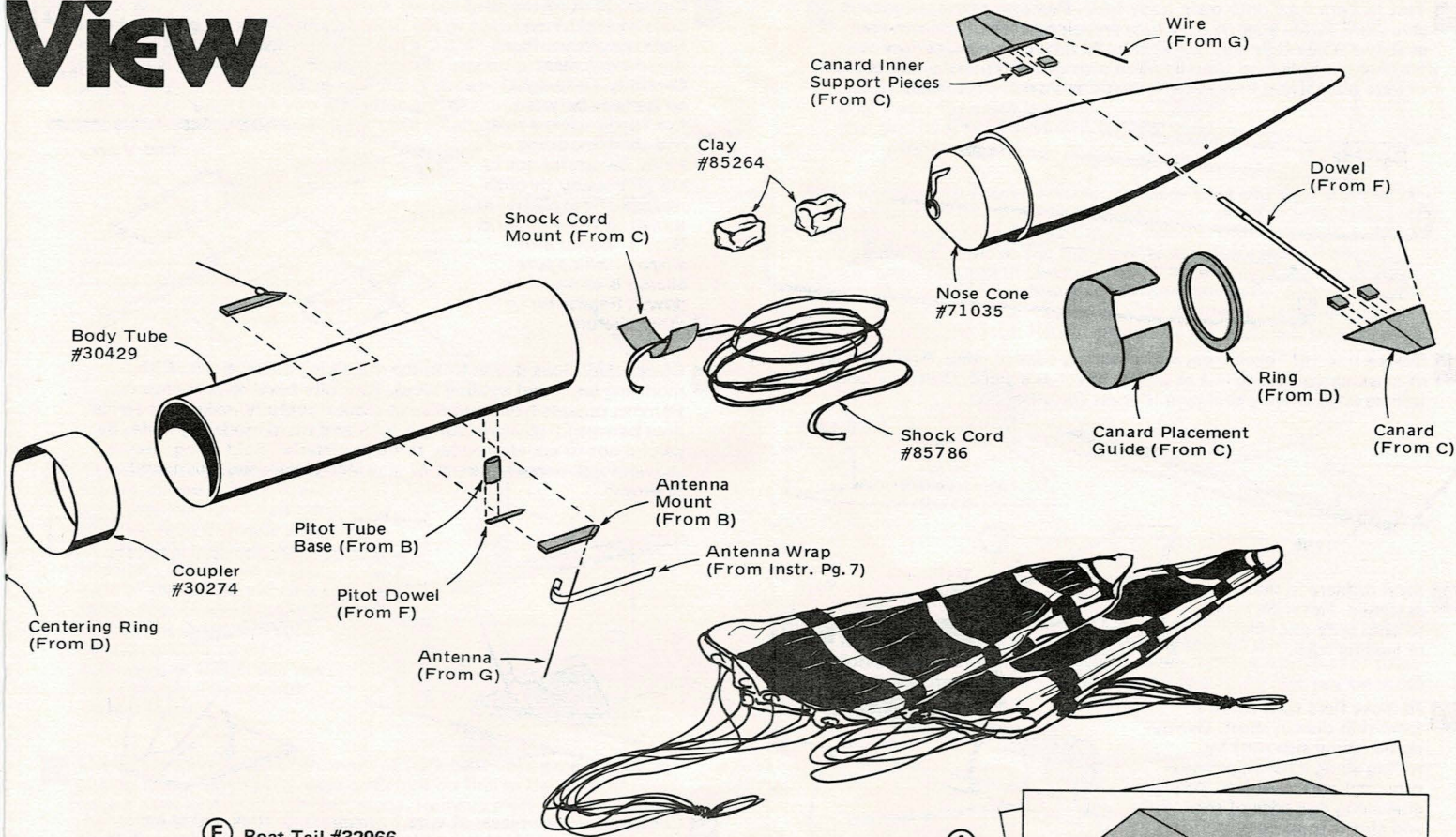

E Boat-Tail #32966

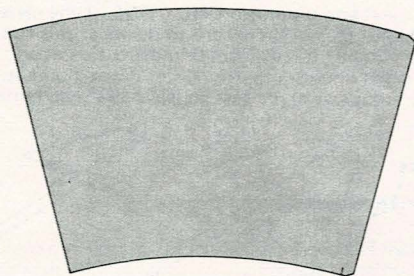

A Rudders #32898

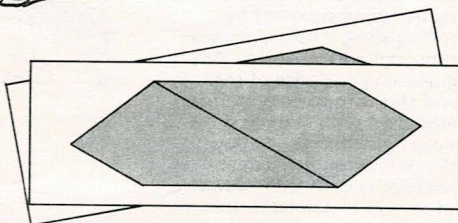

B Wings #32899

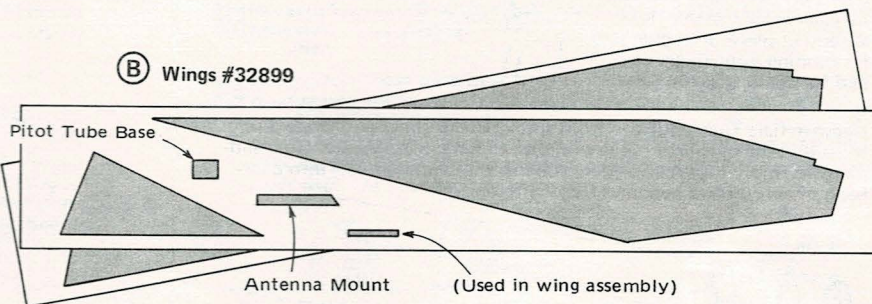

F 1/8 Dowel #85901

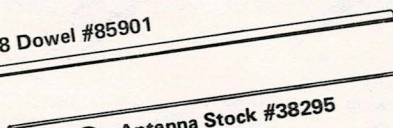

G Antenna Stock #38295

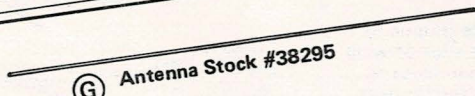

C Thin Die-Cut Sheet #39264

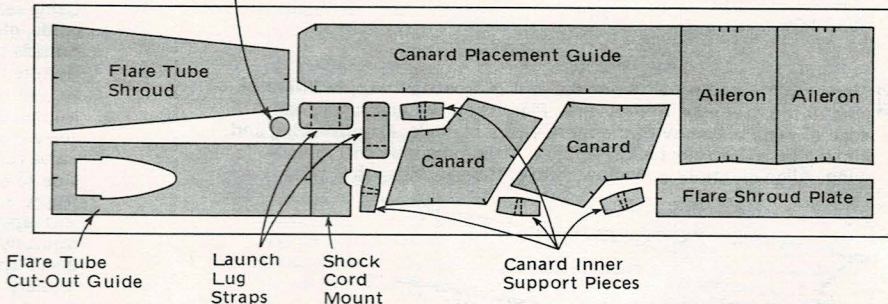

D Thick Die-Cut Sheet #32965

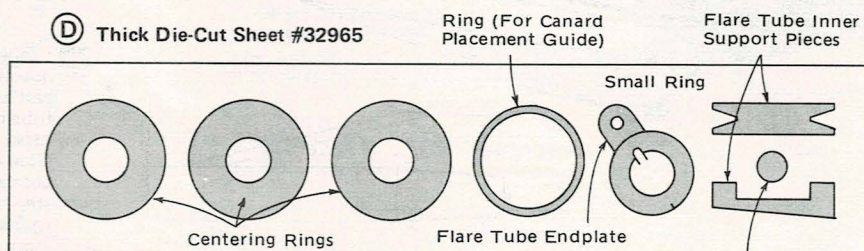

RECOMMENDED LAUNCH SYSTEM:

- #5601 Power Tower Launch Stand
- #5623 Power-Control Controller
- #5803 Heavy-Duty 3/16" Launch Rod (Rod available by mail order for \$1.75 plus \$1.50 handling). May substitute 3/16" pianowire or welding rod.

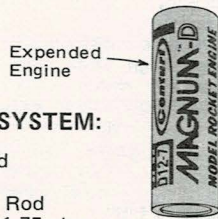

Avoid eye injury by capping the exposed tip of the launch rod when not actually launching. Follow the instructions and the Safety Code, and have many happy hours with model Rocketry.

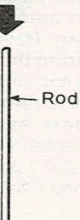

- 18** Test fit flare tube onto main body tube. Remove and apply a line of glue along inside edge of flare tube and along edge of support piece as shown. Glue flare tube to main body tube making sure nose cone fits into cut hole, and support piece aligns with centering tick marks or base plate. Hold in place with masking tape or rubber bands.

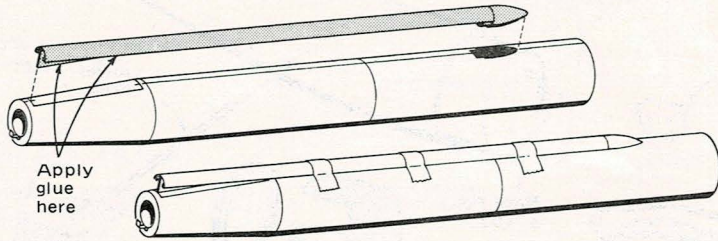

- 19** Draw a line 1/2" back from entire leading edge of wing. Apply 3-4 layers of masking tape along line as shown to act as a guide. Carefully bevel leading edge of wing as shown. Repeat for other side.

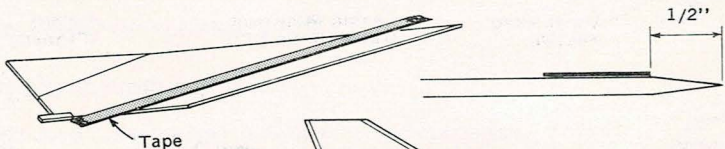

- 20** Sand rudders to shape as shown. Note: Be sure to sand only one side of leading edge.

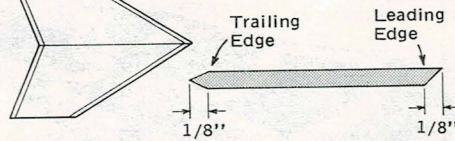

- 21** Remove flare tube shroud from thin die-cut sheet. Gently shape (shiny side out) by rolling along a pencil or some other cylindrical object. Apply glue along one edge of shroud and glue into place with front edge even with seam as shown. Apply glue fillet and allow to dry. When the first side is dry, apply glue to second edge of shroud and bend shroud over flare tube until it butts up against base plate. Hold shroud in place until glue sets by running your finger back and forth along seam.

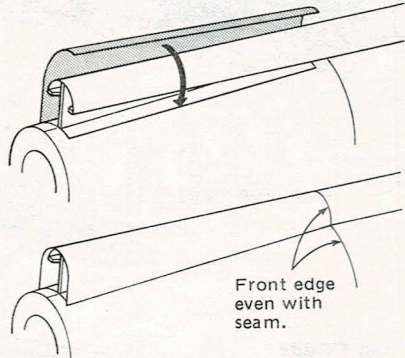

- 22** Remove flare tube endplate from thick die-cut sheet and small disc from thin die-cut sheet. Glue thin disc to back of endplate. Glue endplate assembly into rear of flare tube so that endplate fits into overhang of shroud and becomes flush with end.

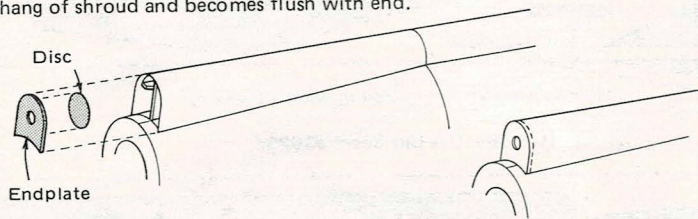

- 23** Mark each wing line 1" from the end of boat-tail. Apply a line of glue to the root edge of one wing. Place it on the line so the rear edge of wing is even with the mark you just made. Remove wing and allow glue to become tacky. Apply a little more glue and replace wing. Align carefully and allow to dry. Repeat with other wing.

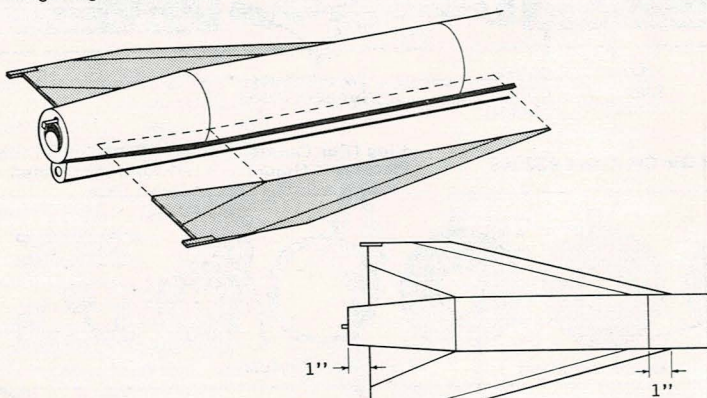

- 24** Cut two 3" long sections of 1/8" dowel. Remove ailerons from thin die-cut sheet. Carefully make light scribe lines between tick marks using a ruler and sharp modeling knife. Be careful not to cut all the way through material. Fold aileron as shown and glue together. Glue 3" dowel into aileron making sure aileron is centered on dowel. Repeat for other aileron.

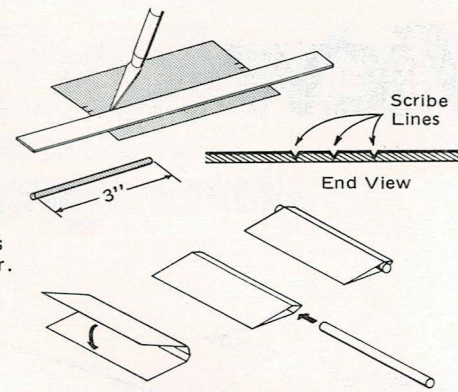

- 25** Cut a 5-1/4" long dowel from the remaining dowel stock. With a modeling knife and sanding block, carefully bevel ends as shown. Remove canards from thin die-cut sheet. Carefully make light scribe lines between tick marks using a ruler and sharp modeling knife. Be careful not to cut all the way through material. Fold along lines as shown. Place a small amount of glue along edges and glue together as shown.

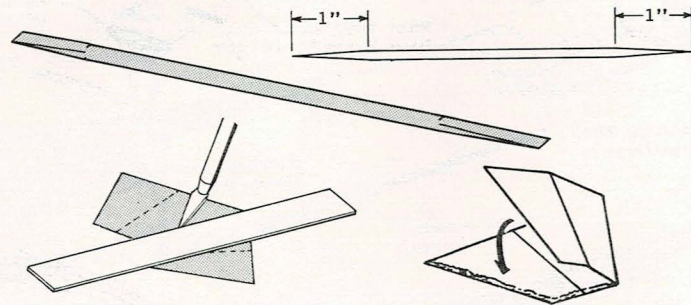

- 26** Cut two one inch pieces of wire from antenna stock. Using epoxy or Ambroid cement, glue into leading edge of canard (edge with fold) so that 1/8" sticks out. Repeat with second canard. Apply glue to one end of beveled dowel and push into ONLY ONE of the canards until its a snug fit. Do not glue other canard to dowel at this time! Remove canard inner support pieces from thin die-cut sheet and fold as shown. Glue into place in both canards. Note: When gluing support pieces into canard without dowel, be sure to leave 1/8" gap between pieces.

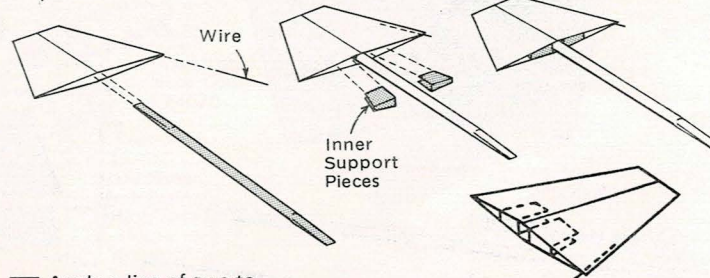

- 27** Apply a line of glue to the outside edge of wing. Using seam in balsa as guide, glue rudder onto outside edge of wing. Be sure to glue rudder so that the bevel on the leading edge is facing away from model. Remove rudder and allow glue to become tacky. Apply a little more glue and replace rudder. Align carefully and allow to dry. Repeat with other rudder.

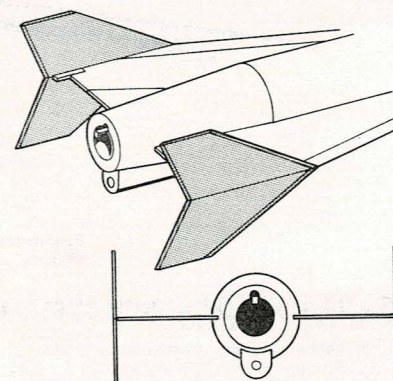

- 28** Cut a 1" long piece of 1/8" dowel from stock. Bevel one end as shown. Remove pitot tube base from thick die-cut balsa sheet and sand to shape. Glue dowel to pitot tube base as shown. As an optional step for strength you may wish to insert a short piece of wire from antenna stock into base as shown.

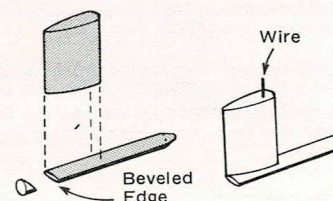

- 29** Remove antenna mounts from thick die-cut balsa sheet. Sand bevel into front edge as shown. With a push pin or sewing needle, carefully make a pilot hole at angle shown. Cut a 2-3/4" length antenna from wire stock. Cut antenna wraps (bottom of second column page 7) from instructions and glue to antenna as shown. Carefully insert antenna into pilot hole you just made and glue in place with epoxy or Ambroid cement. Repeat for second antenna.

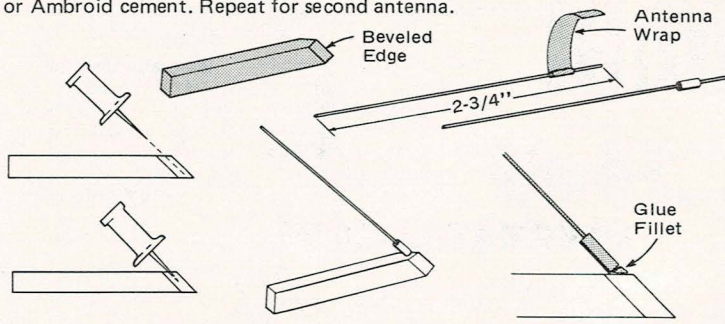

- 30** Test fit aileron into place as shown. If dowel is too long, sand each end until you get a snug fit. NOTE: Inside edge of aileron is angled to follow boat-tail. Apply glue to the ends of the dowel and along inside edge (angled) and position as shown. Be sure to align aileron straight with wing or model will not fly correctly. Repeat with other aileron.

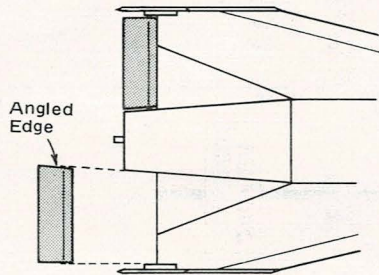

- 31** Mark flare tube line 3/4" from tip of flare tube nose cone. Apply glue to root edge of pitot tube and place on line so that rear of pitot tube is even with mark you just made. Remove pitot tube and allow glue to become tacky. Apply a little more glue and replace making sure of proper alignment.

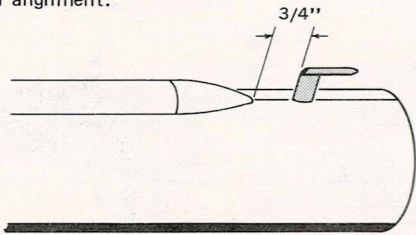

- 32** Mark antenna lines 3-1/4" from front edge of main body tube. Apply glue to root edge of antenna mount and place on line so front edge is even with mark you just made. Remove antenna mount, allow glue to become tacky. Apply a little more glue and replace antenna. See end view for proper alignment. Repeat for other antenna.

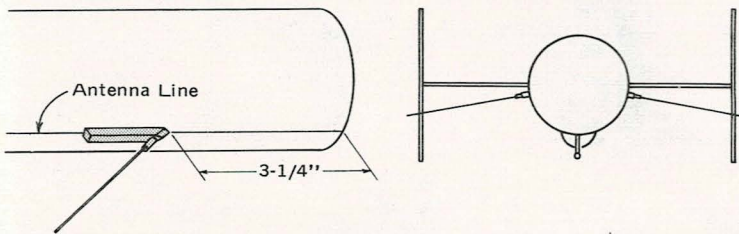

- 33** Mark the inch long launch lug at the midway point and cut with a sharp modeling knife by pressing on a hard surface. To fix crunching caused by cutting, simply place launch lug on end of pencil and rotate back and forth until round. Glue lugs onto main body along drawn line as shown. Remove launch lug straps from thin die-cut sheet and glue one over each lug as shown.

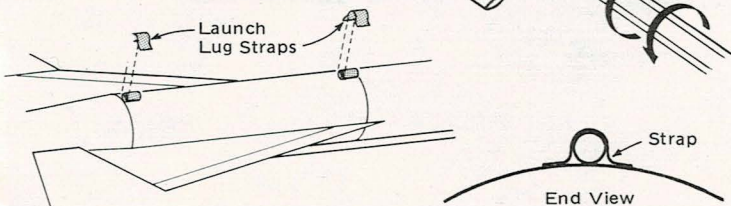

- 34** Remove canard placement guide from thin die-cut sheet and ring from thick sheet. Glue placement guide together using tick marks for proper alignment. Glue ring into the end that does NOT have the tick marks.

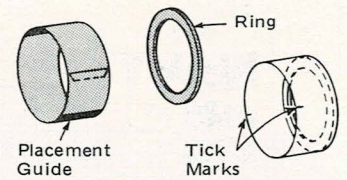

- 35** Slide canard placement guide onto nose cone and align tick marks with seam in plastic. Mark nose cone with pencil at both nicks (one on each side). Remove guide. Make a 1/8" hole (just wide enough for dowel to slip through) by rotating a sharp modeling knife back and forth as shown. Mark seam 1 inch forward of hole you just made. Like above, with a modeling knife, make another much smaller hole on the mark. Hole should be just large enough for wire to slip into. Repeat procedure for other side of nose cone.

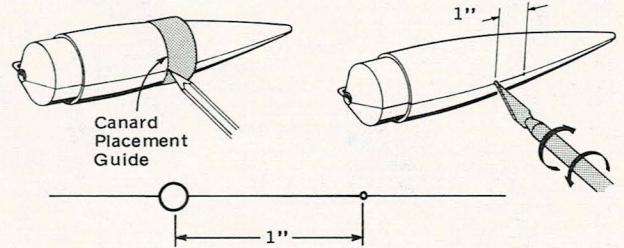

- 36** Locate the shock cord and mount. Tie the shock cord around the mount as shown. Apply glue to the mount and glue in place in forward end of main body tube at least 2 inches from end of tube. Tamp the mount firmly in place and allow to dry. Do not tie shock cord and nose cone at this time.

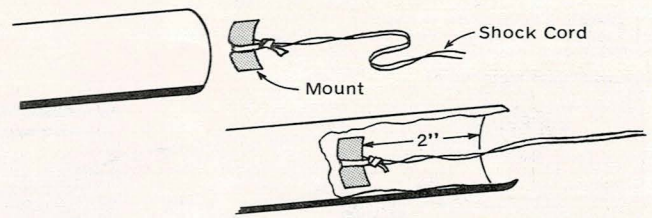

- 37** Apply a final set of fillets to all glue joints and allow to dry thoroughly before further handling.

- 38** Wash plastic nose cone in soapy warm water to remove any mold residue that might be left. This will keep paint from peeling during masking. Mask off base of nose cone and paint entire cone gloss black. After paint is thoroughly dry, slide canard placement guide back on nose cone. Wrap a piece of masking tape all the way around cone with 1/8" overlapping onto cone.



- 39** Place nose cone in front end of body tube and spray entire model with white primer. After primer dries, paint several light coats of orange over entire model and one final finish coat.

RECOMMENDED COLORS:
Krylon Mandarin Orange
Krylon Gloss Black

- 40** The canards should be painted orange, and done separately from rest of model. When paint is dry, slide the dowel/canard assembly through the 1/8" hole. Glue on the remaining canard by inserting the wire into the hole first as shown at right.

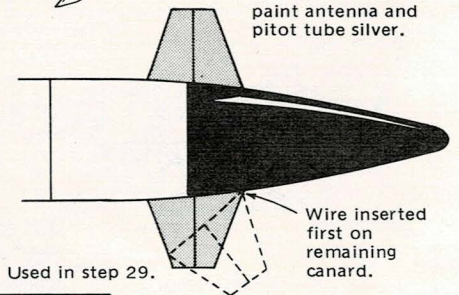
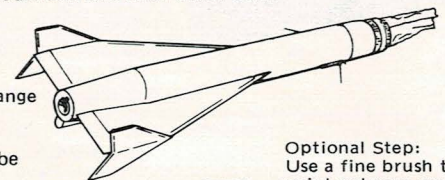

ANTENNA WRAPS: Used in step 29.

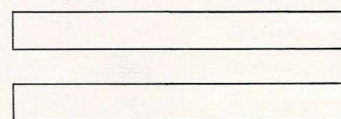

.012"

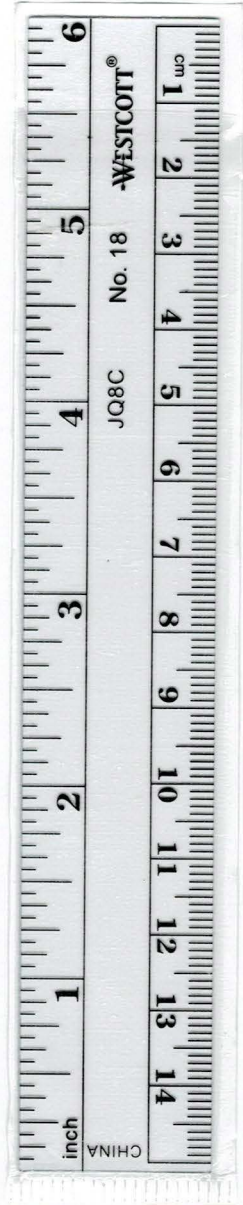

.012"

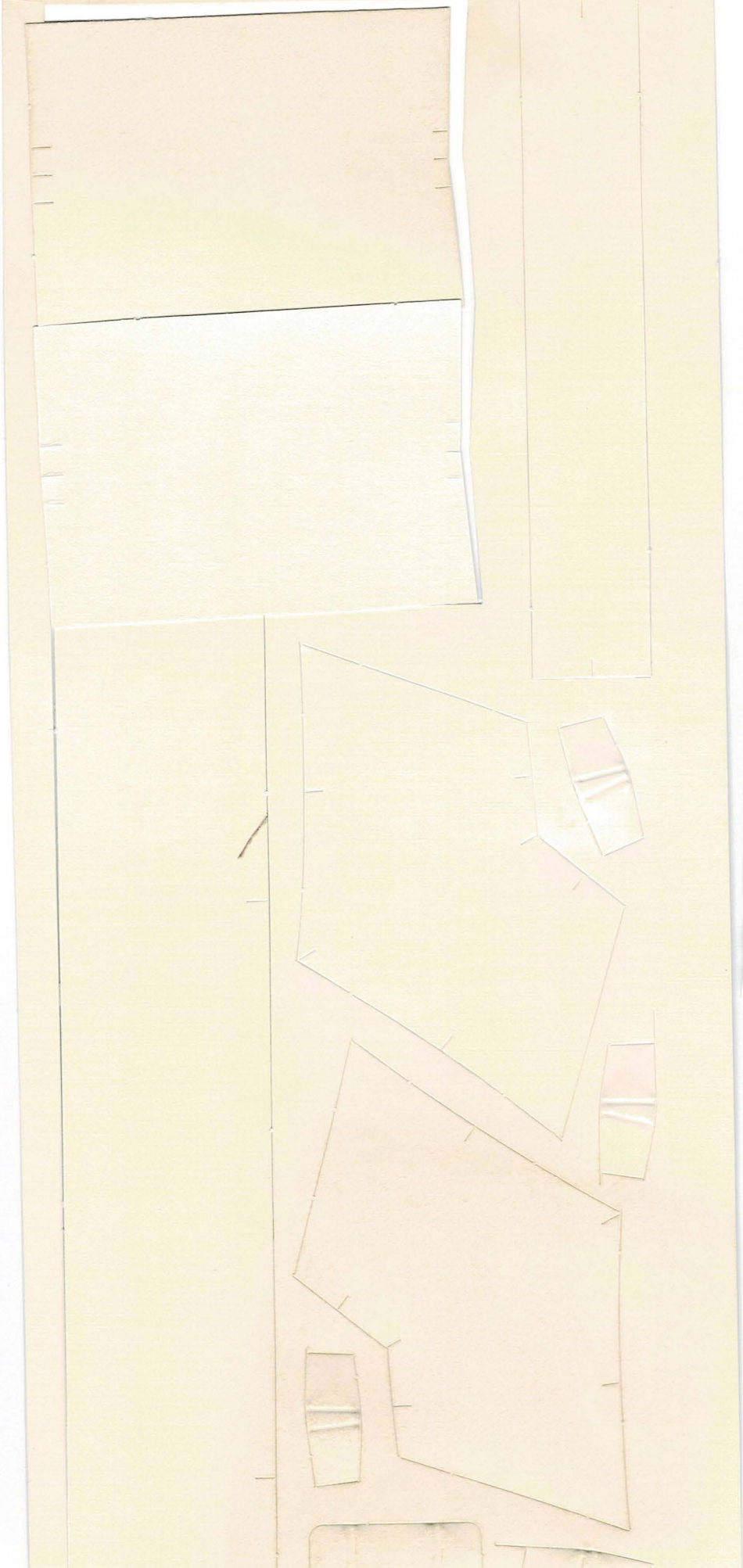
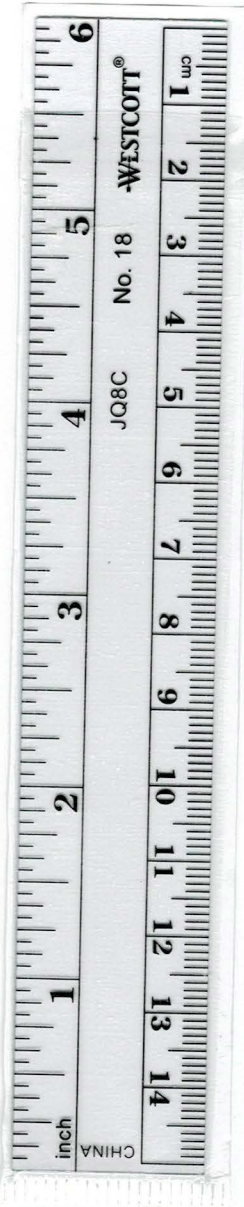

.012"

PN 82964

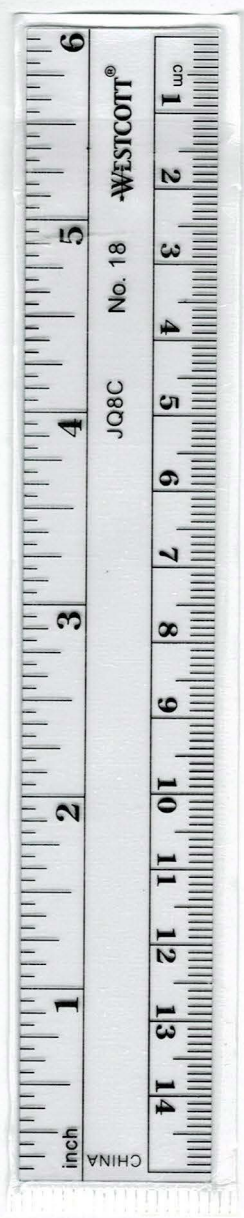
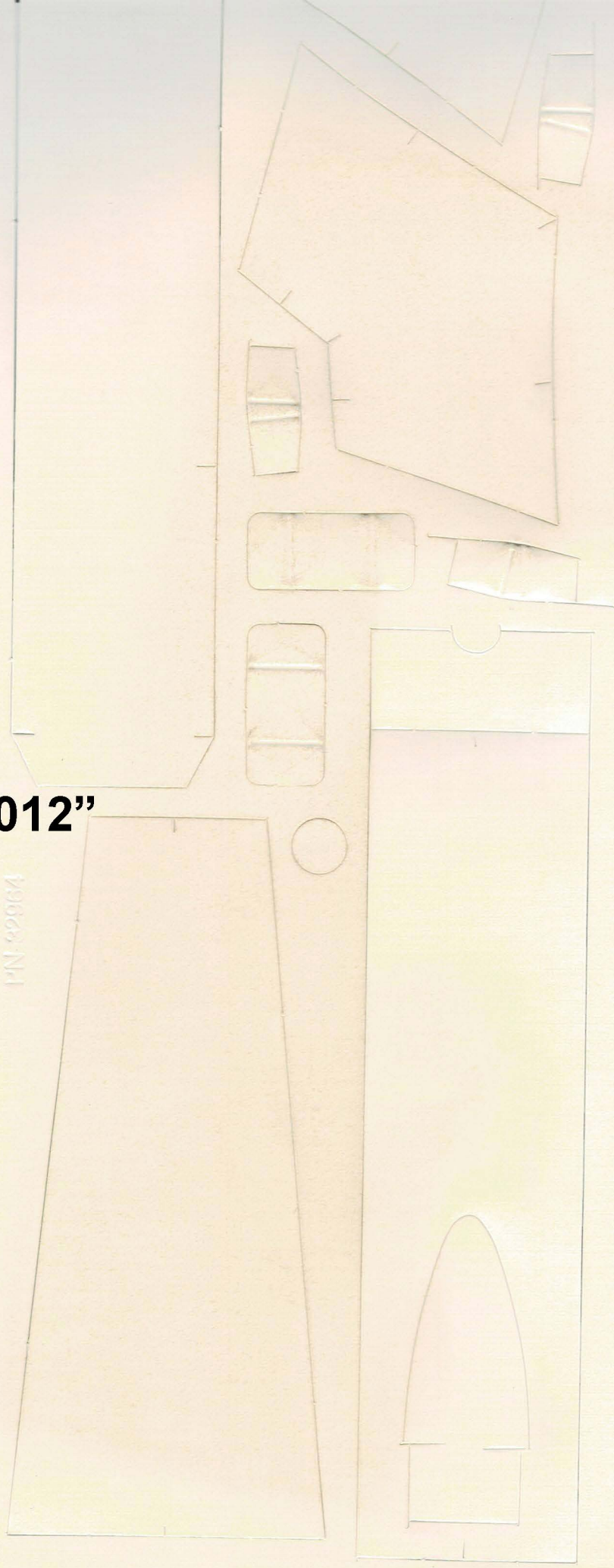

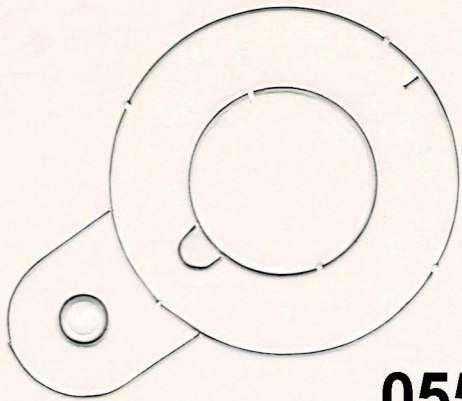
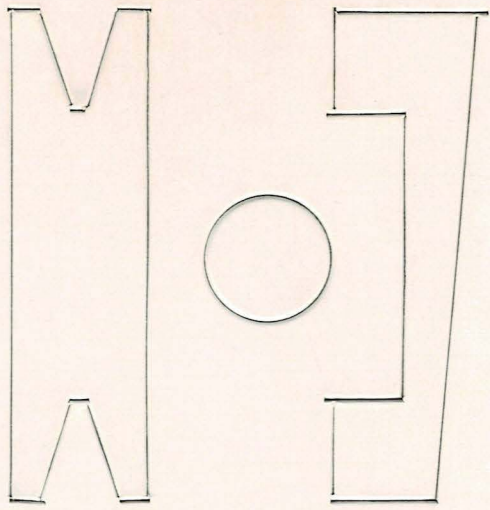

.055"

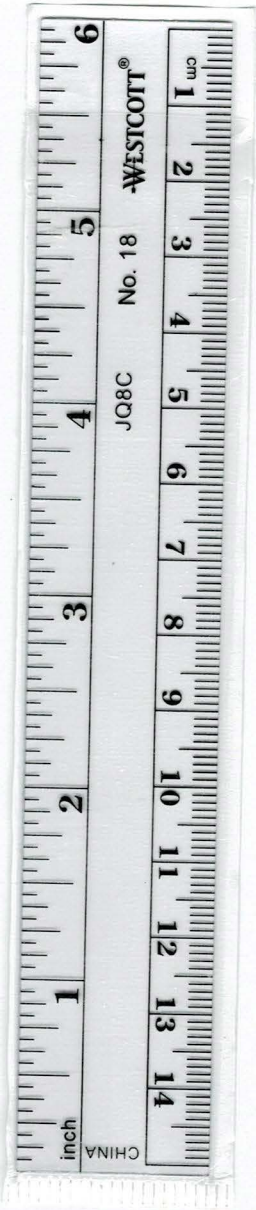
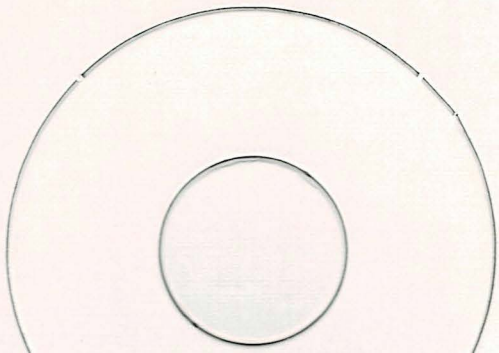
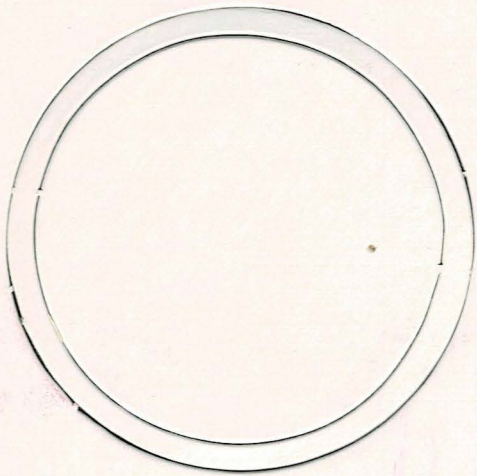

PN: 82365

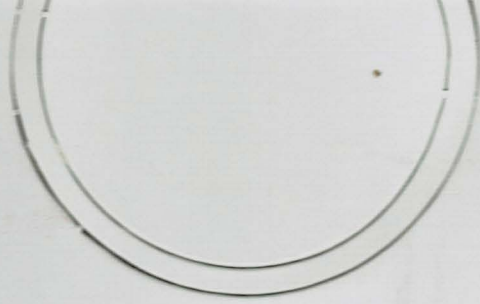
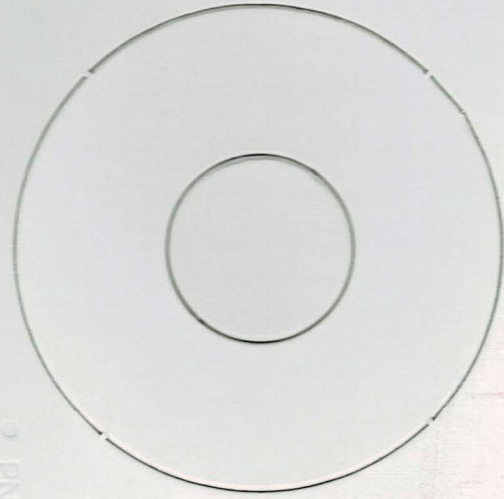
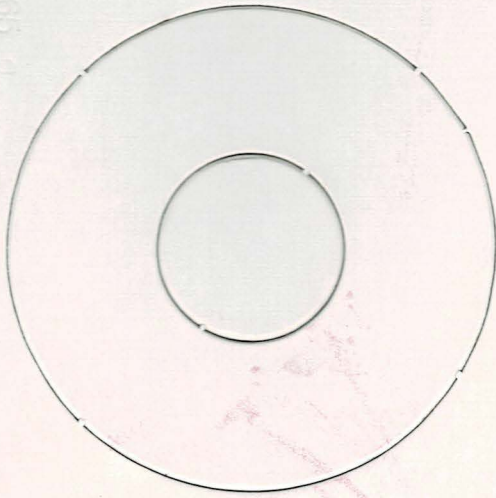
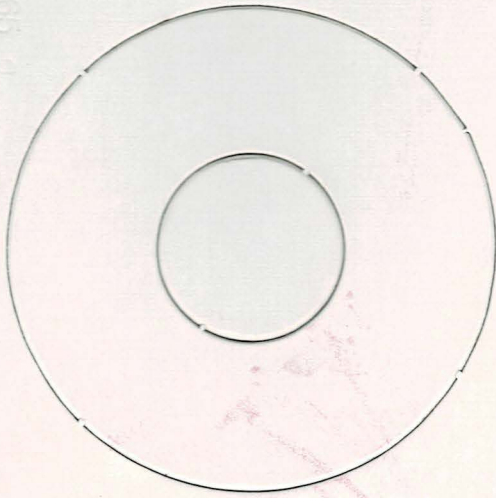
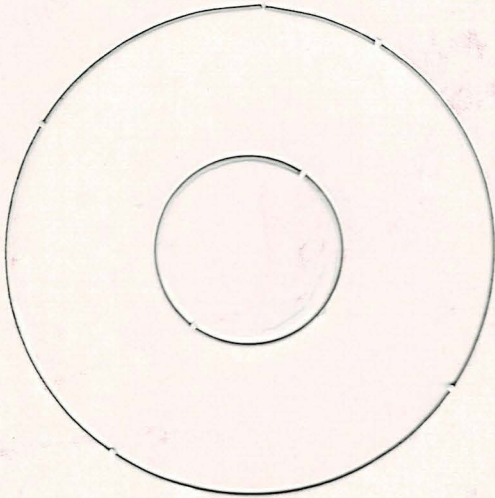

.055"

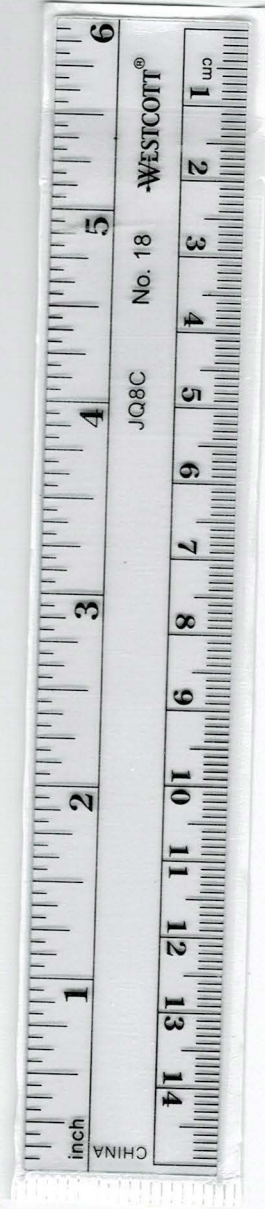

1/8"

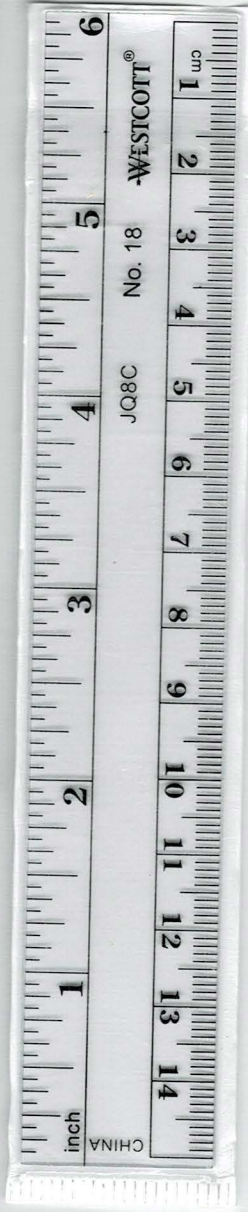

1/8"

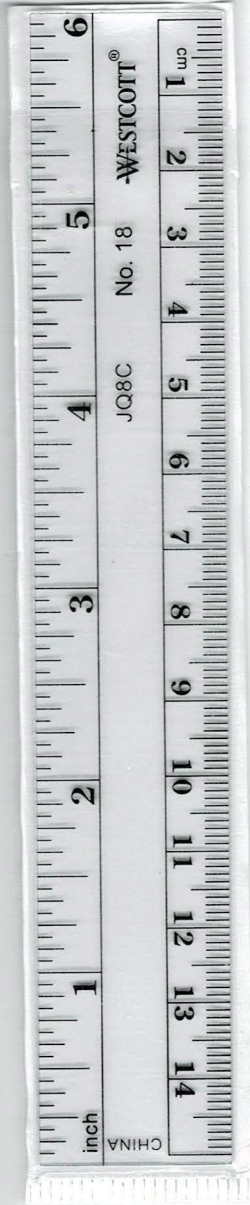

3/32"

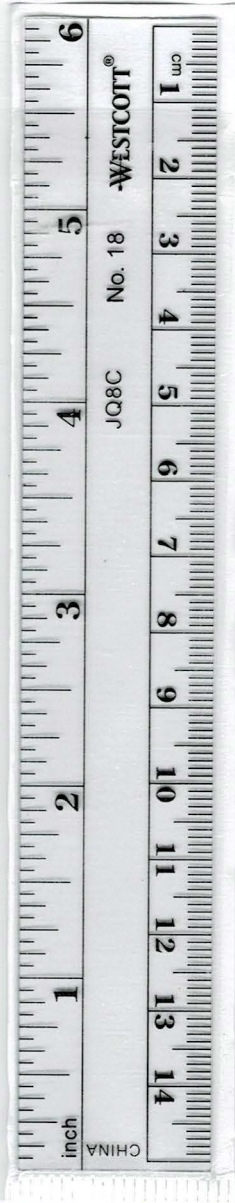

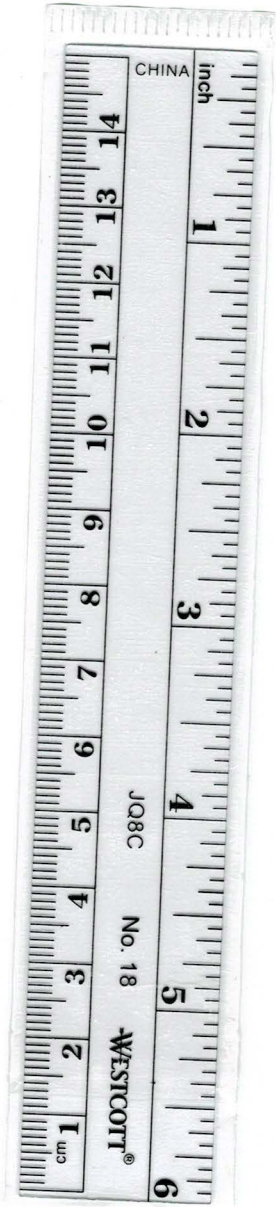
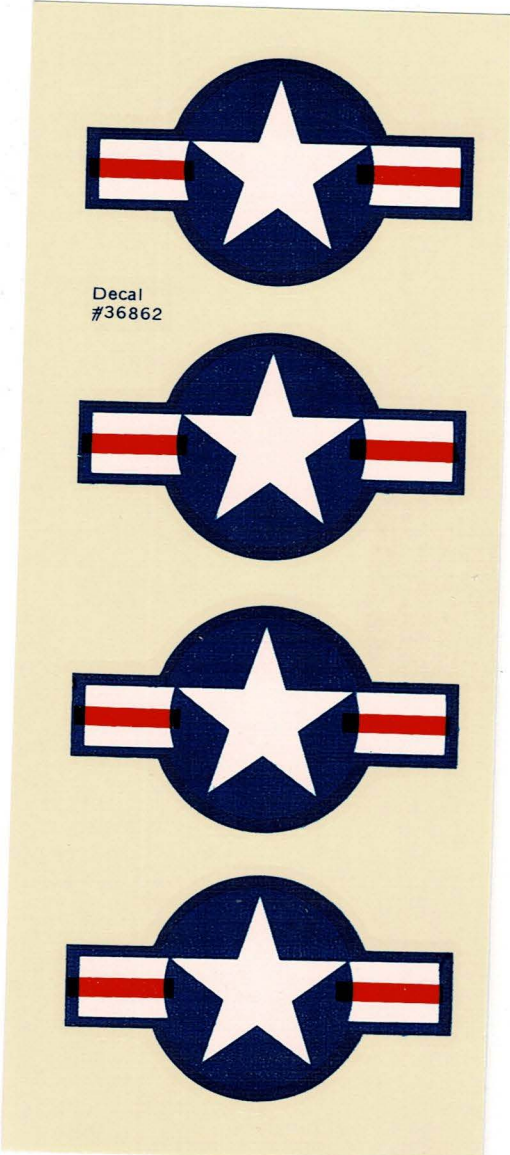

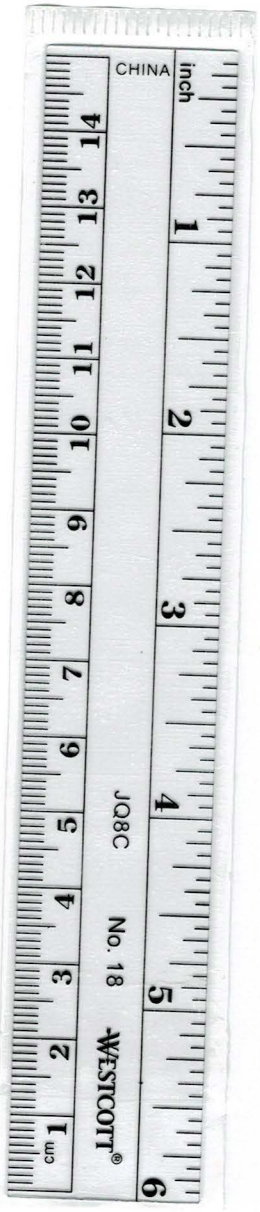

NAVY

TARGET

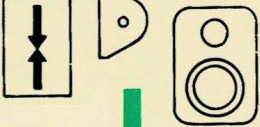

DANGER
MIXED AMINE FUEL
FLAMMABLE - TOXIC
DO NOT PUNCTURE

TARGET

DANGER
FUMING NITRIC ACID
DO NOT PUNCTURE

TARGET

Decal #36863

DANGER
MIXED AMINE FUEL
FLAMMABLE - TOXIC
DO NOT PUNCTURE

DANGER
FUMING NITRIC ACID
DO NOT PUNCTURE

ACCESS
PROPELLANT CARTRIDGES

UMBILICAL CONNECTOR
J101
28V DC 26 AMP MAX



ACCESS
BOOSTER AND SUSTAINER SELECT
PRESSURE REGULATOR
NITROGEN PRESSURE CARTRIDGE
BOOSTER SHUTOFF CARTRIDGE
AERO DESTRUCT CARTRIDGE
G.W.S.

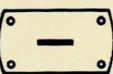

HARD AREA
CRADLE HERE

HARD AREA
CRADLE HERE

HARD AREA
CRADLE HERE

HARD AREA
CRADLE HERE

HARD AREA
CRADLE HERE

AQ-10200

WING ATTACH BOLT - MAX TORQUE 150 IN. LB

WING ATTACH BOLT - MAX TORQUE 150 IN. LB

WING ATTACH BOLT - MAX TORQUE 150 IN. LB

WING ATTACH BOLT - MAX TORQUE 150 IN. LB

FLIGHT CONTROL
PANEL ACCESS

NITROGEN FILL

SWAY BRACE PAD

SWAY BRACE PAD

AQM-37A

AQM-37A

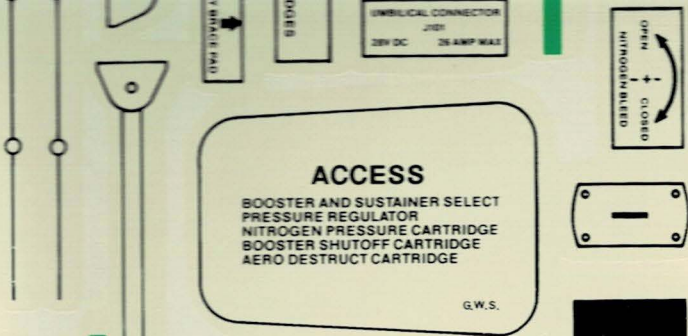

AQ-10206

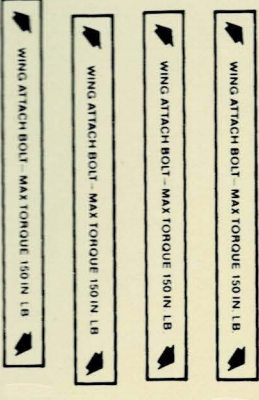

NAVY NAVY

TARGET TARGET TARGET TARGET



BATTERY AND TRANSPONDER ACCESS

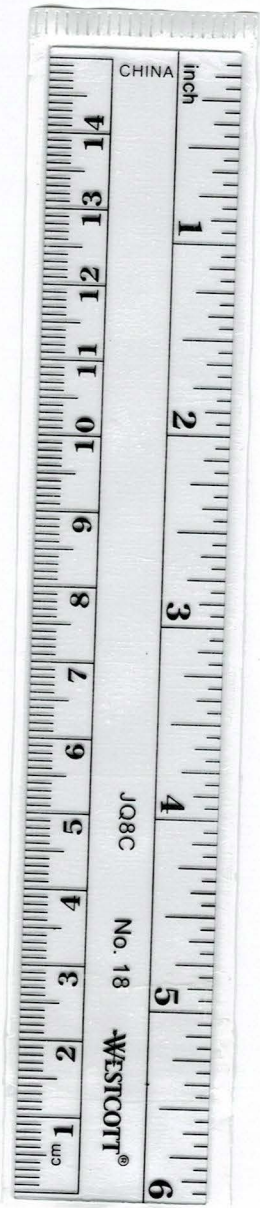
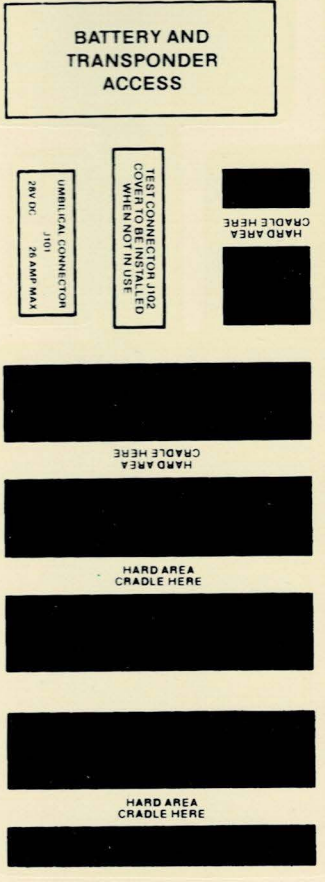

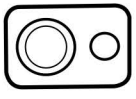

BATTERY AND
TRANSPONDER
ACCESS

AQ-10206

AQM-37A



ACCESS
BOOSTER AND SUSTAINER SELECT
PRESSURE REGULATOR
NITROGEN PRESSURE CARTRIDGE
BOOSTER SHUTOFF CARTRIDGE
AERO DESTRUCT CARTRIDGE

UMBILICAL CONNECTOR
J101
28V DC
26 AMP MAX

WING ATTACH BOLT --- MAX TORQUE 150 IN. LB.

WING ATTACH BOLT --- MAX TORQUE 150 IN. LB.

WING ATTACH BOLT --- MAX TORQUE 150 IN. LB.

WING ATTACH BOLT --- MAX TORQUE 150 IN. LB.

NAVY

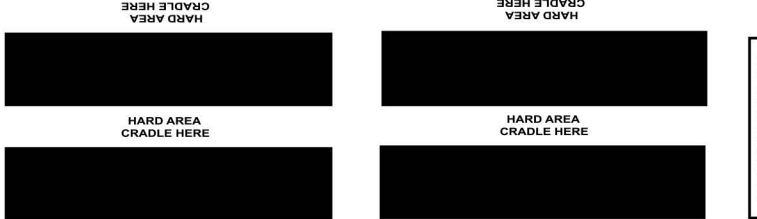
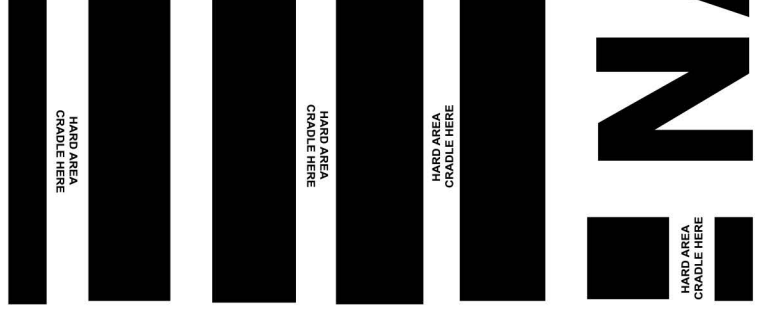

TEST CONNECTOR J102
COVER TO BE INSTALLED
WHEN NOT IN USE

FLIGHT CONTROL
PANEL ACCESS



NAVY NAVY

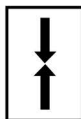

UMBILICAL CONNECTOR
J101
28V DC 26 AMP MAX



NITROGEN FILL

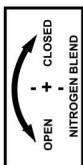

↑
SWAY BRACE PAD

ACCESS
PROPELLANT CARTRIDGES

↑
SWAY BRACE PAD



TARGET TARGET



DANGER
MIXED AMINE FUEL
FLAMMABLE--TOXIC
DO NOT PUNCTURE



DANGER
MIXED AMINE FUEL
FLAMMABLE--TOXIC
DO NOT PUNCTURE

TARGET
TARGET

TARGET



TARGET

DANGER
FUMING NITRIC ACID
DO NOT PUNCTURE

TARGET

DANGER
FUMING NITRIC ACID
DO NOT PUNCTURE

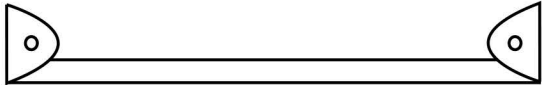
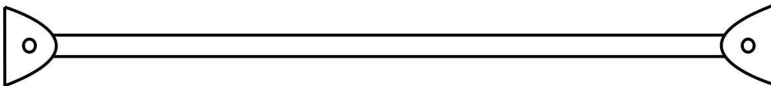

ENGINEERING COMPANY

CP-20

Chute Pak

PARACHUTE ASSEMBLY DIRECTIONS

Cut out plastic canopy carefully, following dashed lines. Cut shroud line into four 32" lengths.

1

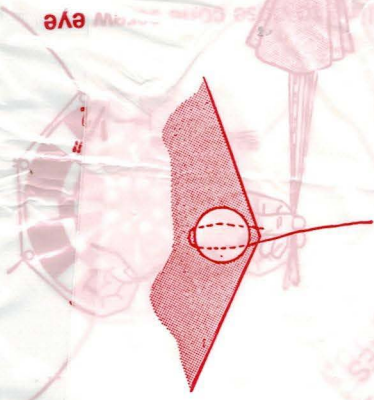

CUT OUT CAREFULLY ALONG DOTTED LINES

ATTACH SHROUD LINE HERE

CUT OUT CAREFULLY

ATTACH SHROUD LINE HERE

ATTACH SHROUD LINE HERE



ATTACH SHROUD
LINE HERE

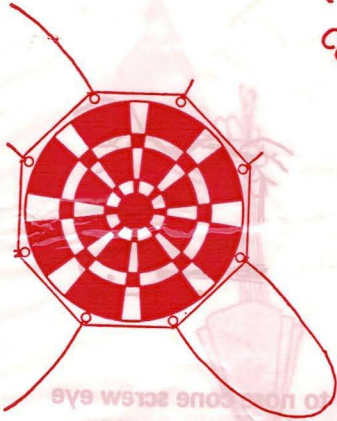

2

As shown in Figure 1, form a 1/2" loop in the end of shroud line, place loop over indicated dot, and position tape disc over loop. Press disc firmly onto plastic. Attach free end of shroud to adjacent dot. Repeat for all shroud lines as shown in Figure 2.

CUT OUT CAREFULLY ALONG DOTTED LINES



ATTACH SHROUDA
LINE HERE

LONG DOTTED LINES

ATTACH SHROUD
LINE HERE

Hold canopy at its center, printed side out.
Pull all lines together and even up ends. Tie
all lines together with a single knot near the
end.

3



CUT OUT CAREFULLY ALONG DOTTED LINES

ATTACH SHROUD
LINE HERE

DOTTED LINES

7UR1

ATTACH SHROUD LINE HERE

CUT OUT CAREFULLY ALONG DOTTED LINES

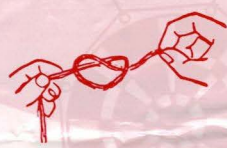

Tie shroud line to nose cone screw eye on your model rocket

4



ENGINEERING COMPANY

CUT OUT CAREFULLY



NAVY

DANGER
FLAMMING NITRIC ACID
DO NOT PUNCTURE

TARGET
Overall Length 11.5"

DANGER
FLAMMING NITRIC ACID
DO NOT PUNCTURE

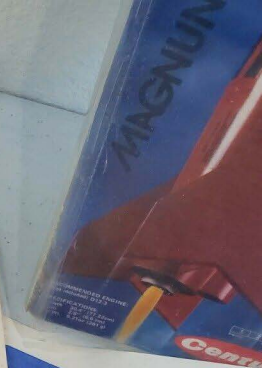
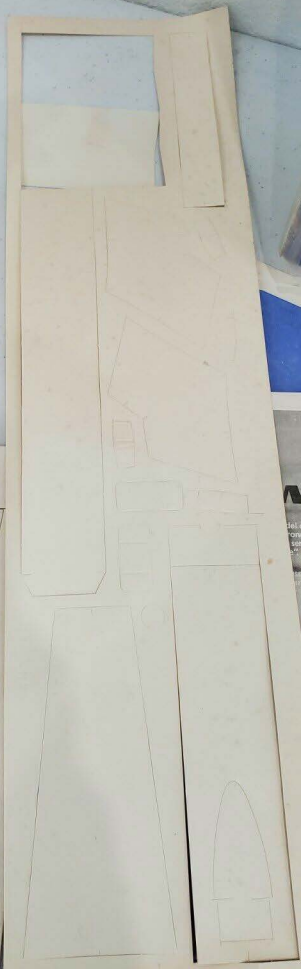

AQM-37A

ET ENTHUSIASTS BY CENTURI ENGINEERING COMPANY, PHOENIX, ARIZONA

MODEL OF THE... The service... The...

nk

19 and 1102 (AQM-37A)

... Choice of two miss...

... and missile threat...

... since 1963... Operational cre...

... the... customers search...

... for... in 1966 by...

... AQM-37A... which...

... produce... (and...

... (missile) has exceeded...

... One... under...

... 1102-174... for... to...

... to evaluate...

... further 10...

... described...

... State...

... 1977

INTENTS
 Engineered View...
 Assembly...
 Decals...
 Recovery system...
 Flying Insurance...

CENTURI Engineering Co., Inc., P.O. Box 1989, P...

Decal
 #1-2

Engines SAFETY CERTIFIED
 Centuri offers over two dozen different engine types in many sizes, power ranges and delay times.

ENERJET STANDARD ENGINES
SUPER G BUILT FOR THE BIG ONES
MAGNUM-D FLY BIGGER - HIGHER - FASTER!

NAR The National Association of Rocketry is the official non-profit organization which promotes model rocketry. Membership includes competition license, contest rule book, decals, subscription to model Rocketeer magazine. Flying insurance is available. For information write: NAR Headquarters, Dept. CB1 182 Madison Dr. Elizabeth, PA 15037

Payload Carriers
 Multi-Stage Rockets
 Space Ships
 Guiders





M-37A

INVENTS
Expanded View
Assembly
Orbits
Recovery System
Firing Instructions

ing Co., Inc., P.O. Box 1988, Ph



MODEL ROCKETS





STANDARD WEIGHT BOND
Catalog



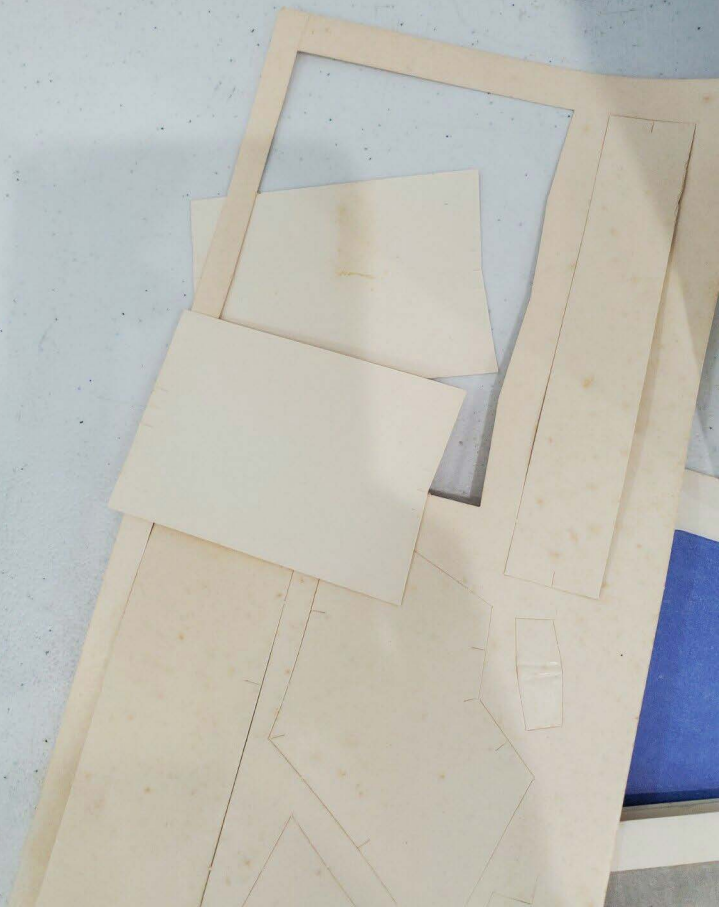

INTRODUCTION

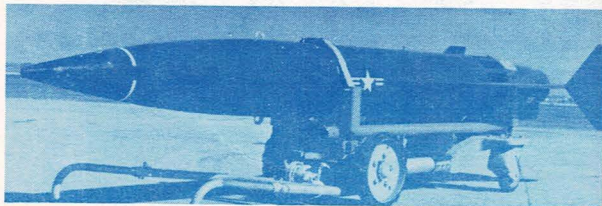

The Jayhawk is a frone type of cruising missile used as a target in aerial combat training. The Jayhawk, shown resting on its handling dolly, gives U.S. Navy pilots practice at supersonic aerial interception. It's low cost and high maneuverability made it ideal for aerial target practice, where fighter pilots could develop lightning fast reflexes.

The AQM-37A Target Missile System has been in continuous use by the U. S. Navy since 1963 with over 2,500 targets having been launched in support of weapon development. The A-4, F-4 and F-8 have been qualified to carry and launch this target. The AQM-37A can be carried in single or multiple loads. The multiple carriage provides wide flexibility and economy of operation.

The Navy AQM-37A Target Missile has great versatility. Its utilization can provide a wide variety of threat simulations for the training of defensive weapon systems crews. It does realistically simulate enemy airborne threats for optical, radar or infrared guided missile systems such as the Sparrow III, Falcon, Sidewinder, Standard and Improved Hawk. Its high performance enables it to provide realistic high rates of closure so that defensive systems are exercised to their limits. Crews that are trained against this target can attain a true "combat ready" status. Radar augmentation enhances the AQM-37A target for most types of missile and tracking systems. The flexibility of the operational envelope is further enhanced by the fact that it is air launched. This allows the mission profile to be orientated in any manner to accommodate the range or specific training and performance requirements.

GENERAL DESCRIPTION

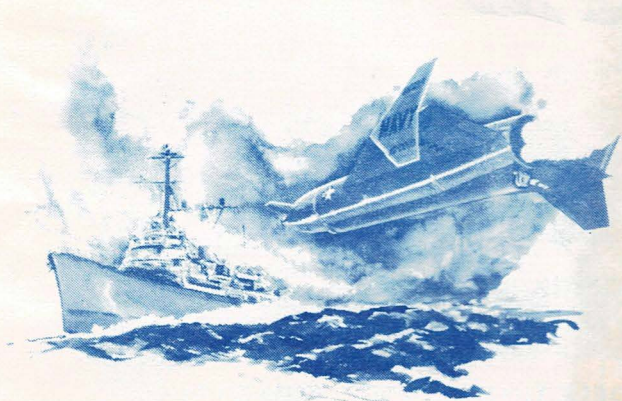

The AQM-37A Target Missile is an expendable rocket powered target missile that is capable of flying missions between 1000 feet and 70,000 feet at speeds ranging from Mach 0.7 to Mach 2.1. It is designed for straight and level flight at various pre-selected altitudes, simulating high performance aircraft and missile threats for evaluation and training of air-to-air and surface-to-air defensive weapons systems. The AQM-37A is air launched from subsonic or supersonic carrier or land based aircraft by the means of an airborne ejection launcher that adapts the target to the aircraft.

The AQM-37A weighs 565 pounds, is 150.8 inches long, 13.0 inches in diameter, and has a highly swept (75°) clipped delta wing with a span of 39.5 inches mounted on a cylindrical streamlined fuselage. Pitch and roll control is maintained by canard surfaces mounted on the nose and full span ailerons located on the trailing edges of the wings. Swept fixed vertical stabilizers are mounted on each wing tip to provide lateral stability. Turns are accomplished by a "roll-to-turn" technique.

The target is equipped with a self-contained guidance system, radar and infrared augmentation systems and a destruct system for flight termination. It is powered by a dual thrust chamber, liquid bi-propellant rocket engine. The bi-propellants are contained in stainless steel pressure vessels that form an integral part of the fuselage. The fuel and oxidizer tanks are fueled during final manufacture of the target and the fueled target can be stored for two years.

AIR DEFENSE SYSTEMS

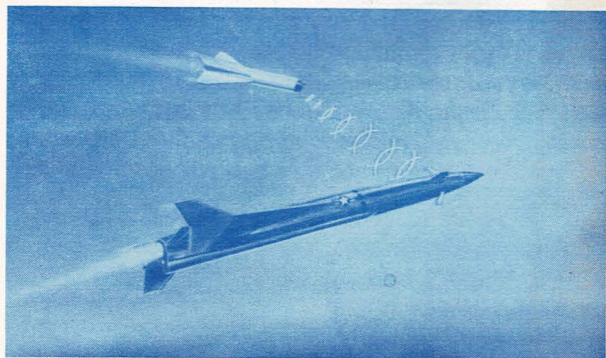

To evaluate the effectiveness of air defense systems with confidence that they will be effective under combat environments it is necessary to simulate the threat as nearly as possible. The more exact the simulation the more accurate the evaluation can be. Operational crews which are an integral part of the weapon systems must be trained under the same exact simulation. At the same time it is necessary that the greatest economy be practiced. The performance and augmentation features of the AQM-37A allows simulation of the widest range of threats. The high altitude and supersonic speed achieved by this rocket powered target are not obtainable by any other target in production.

It is a safe, reliable, suitable target system with a performance envelope of speeds and altitudes suitable for all types of air defense systems. It provides targets for surface-to-air, air-to-air, and ship-to-air defensive systems.

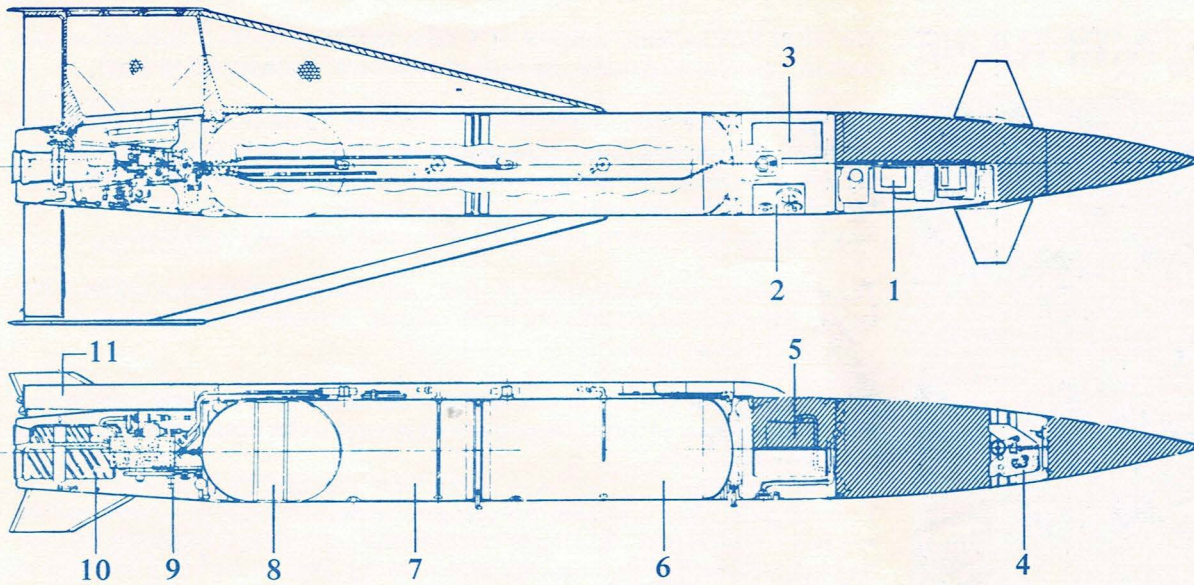

1. Electronic Components
2. Flight Control Panel
3. Batteries
4. Canard Controls
5. Radar Beacon (Optional)
6. Oxidizer Tank (Irfna)
7. Fuel Tank (Maf-4)
8. Pressurant Tank (Nitrogen)
9. Aerodynamic Destructor
10. Rocket Engine
11. Flare Container (Optional)

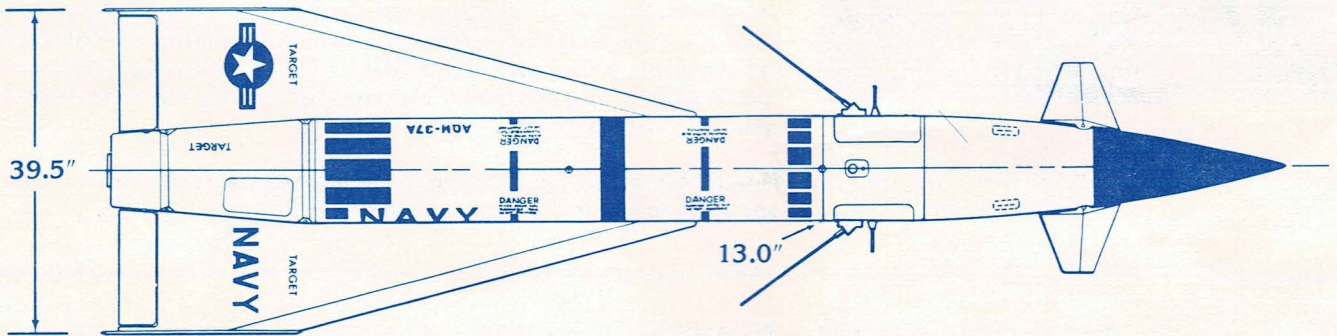

TOP VIEW

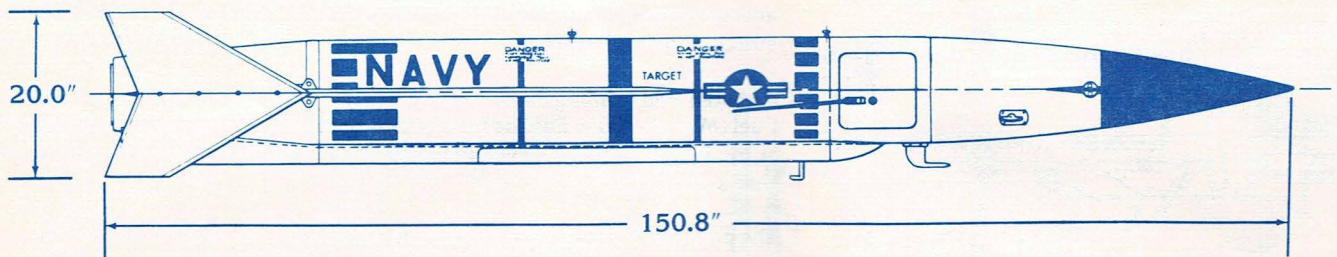

SIDE VIEW

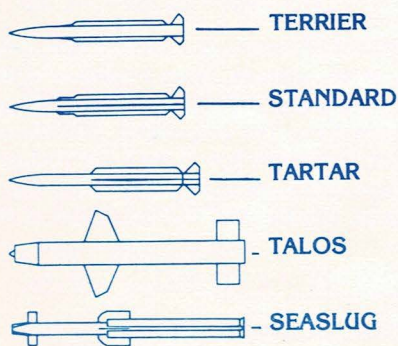

SHIP TO AIR

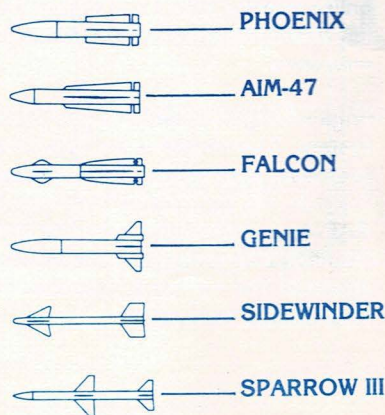

AIR TO AIR

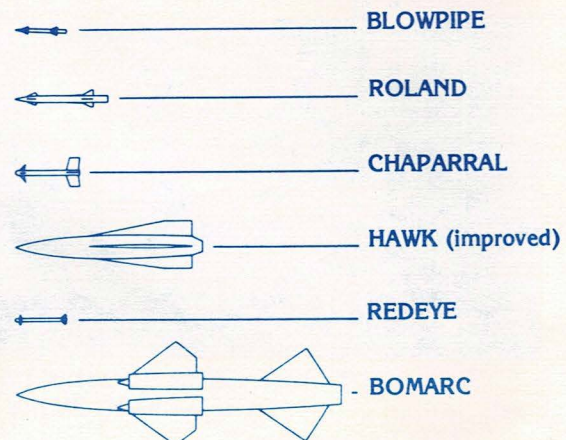

SURFACE TO AIR

AIRFRAME

The AQM-37A airframe consists of a nose section, propellant tankage, engine section, canards, wings, ailerons, vertical stabilizers, and a tunnel section.

The tangent ogive monocoque nose contains the equipment support panel and electronic components. A fiberglass radome nose houses the C-X band radar reflecting lens. The middle nose supports the canard actuator drive assembly and encloses the equipment support panel. The aft nose section contains removable doors for access to the flight control panel, battery assembly and MDI equipment.

The nitrogen pressure tank, fuel tank, and oxidizer tank form an integral part of the target's airframe. These tanks are highly efficient pressure vessels fabricated from 17-7 PH stainless steel.

A tunnel on the lower side of the fuselage houses the rocket engine start valves, plumbing and infrared flares. An access door is provided for installation of propellant start valve cartridges.

The engine section contains the rocket engine, related electronic equipment, and the aileron control assembly. The thrust chambers are enclosed by a removable tail cone fairing. An access door on the engine section hatch provides access for adjustment of the propellant orifice selector valves, and installation of the engine start and aero destruct cartridges.

The wings are one-inch thick, bonded aluminum honeycomb construction with a bonded-in-place aluminum casting for structural attachment. Full span ailerons are attached to the trailing edge of each wing for roll control. Vertical stabilizer end plates mounted at the wing tips provide high level yaw stability. The vertical stabilizers and wings are interchangeable.

Movable canard surfaces, installed on the nose section provide the necessary altitude and pitch control to stabilize the target.

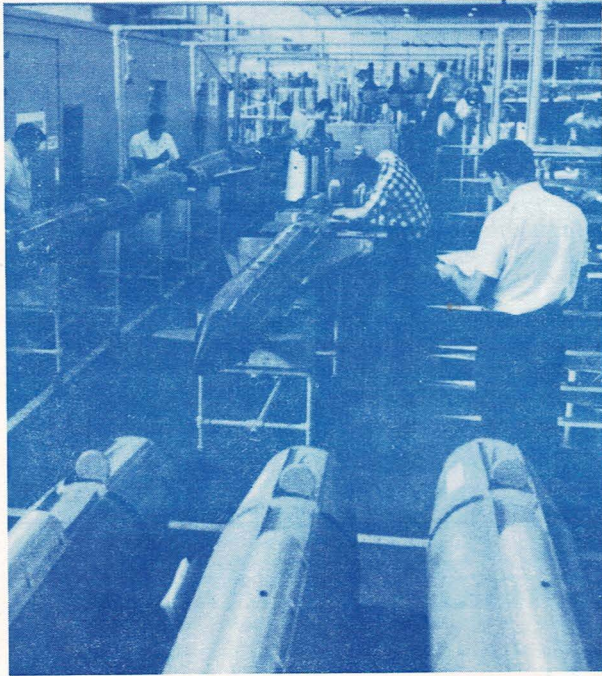

PROPULSION

The AQM-37A Target Missile has a liquid bi-propellant rocket propulsion system. The engine is a prepackaged system consisting of one booster and one sustainer thrust chamber, and orifice selector valves for propellant flow control; fuel, oxidizer, and nitrogen tankage; regulator and start valves; and the necessary interconnecting structure and plumbing.

Inhibited Red Fuming Nitric Acid (IRFNA) is used as an oxidizer and a Mixed Amine Fuel (MAF-4) is used as the fuel. The propellants are hermetically sealed in the tanks at the Beech fueling facility and do not require additional servicing. They have a two year storage life.

The propellant tanks have cartridge operated start valves to permit dry line storage for maximum safety. During operation, propellants are delivered to the thrust chambers under pressure supplied by the nitrogen gas pressurization system. The nitrogen is normally added to the target prior to its installation on the launch aircraft. Boost and sustainer thrusts are then selected for the target mission to be flown by presetting the orifice selector valves and nitrogen pressure regulator. Thirty-two thrust levels ranging from 86 to 860 pounds are available from the booster and sustainer thrust chambers.

Engine firing is initiated shortly after release from the launch aircraft by a time delay system. The engine is capable of starting at any altitude. Upon actuation of the propellant start valves, the propellants feed out of the tanks under pressure through the selected flow orifices into the thrust chambers. The propellants, IRFNA and MAF-4, are hypergolic and ignite upon contact. Propellant flow to the boost rocket is cut off by a cartridge operated valve energized when the preset target Mach number is attained. The sustainer chamber continues to operate until the remainder of the propellant is exhausted.

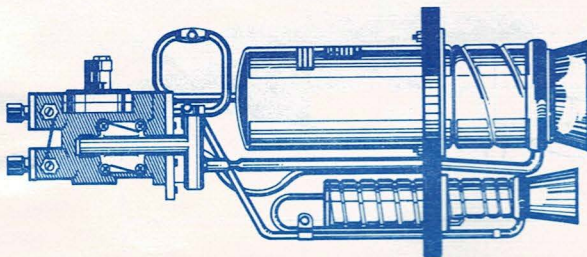

ROCKET ENGINE

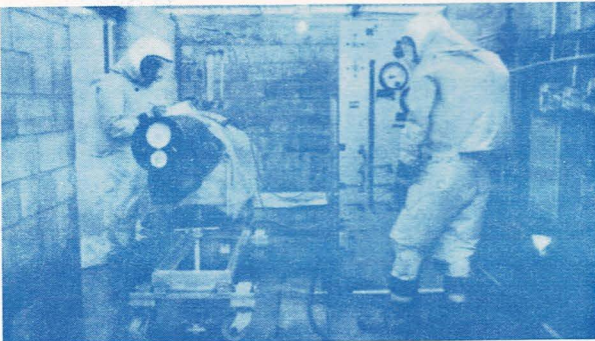

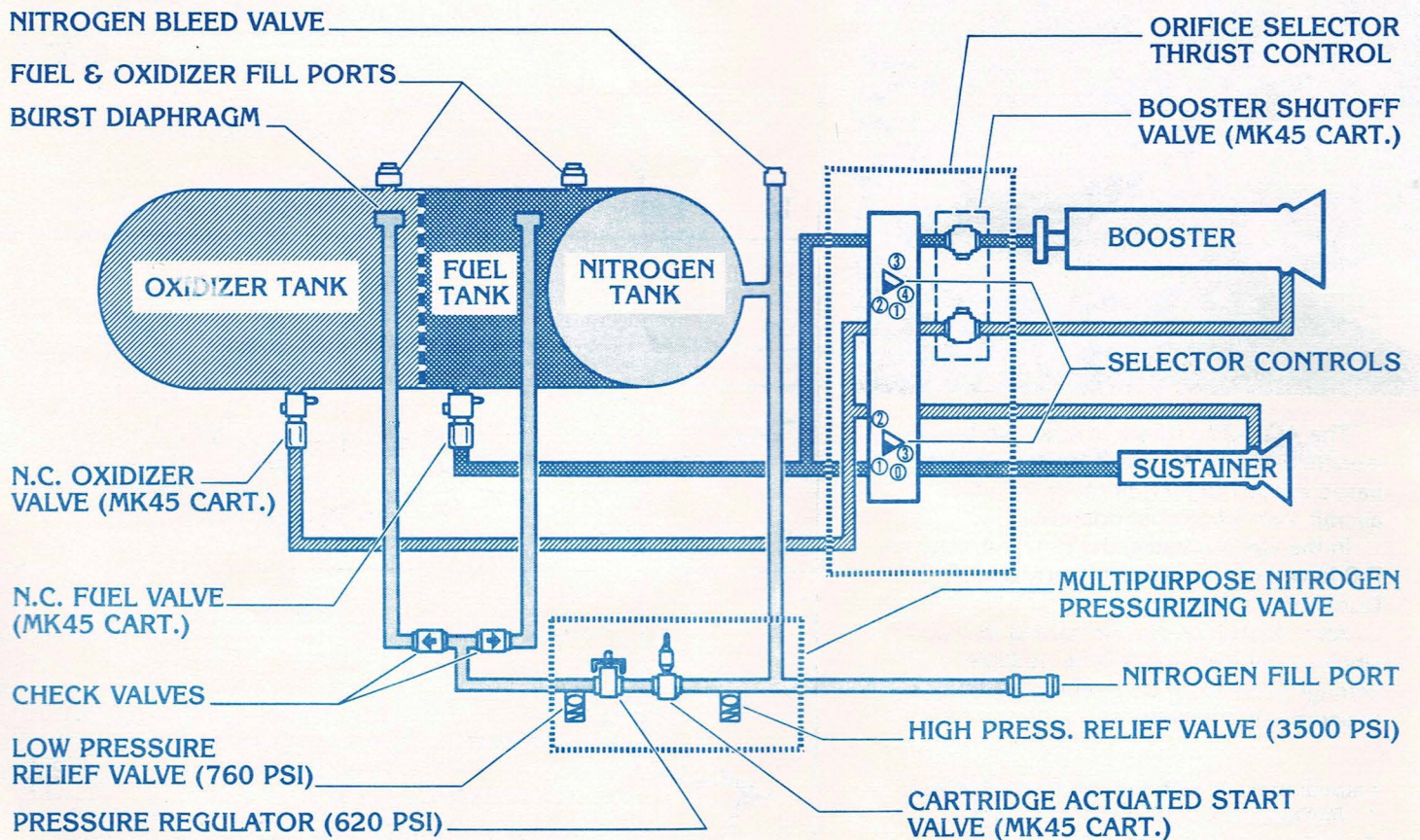
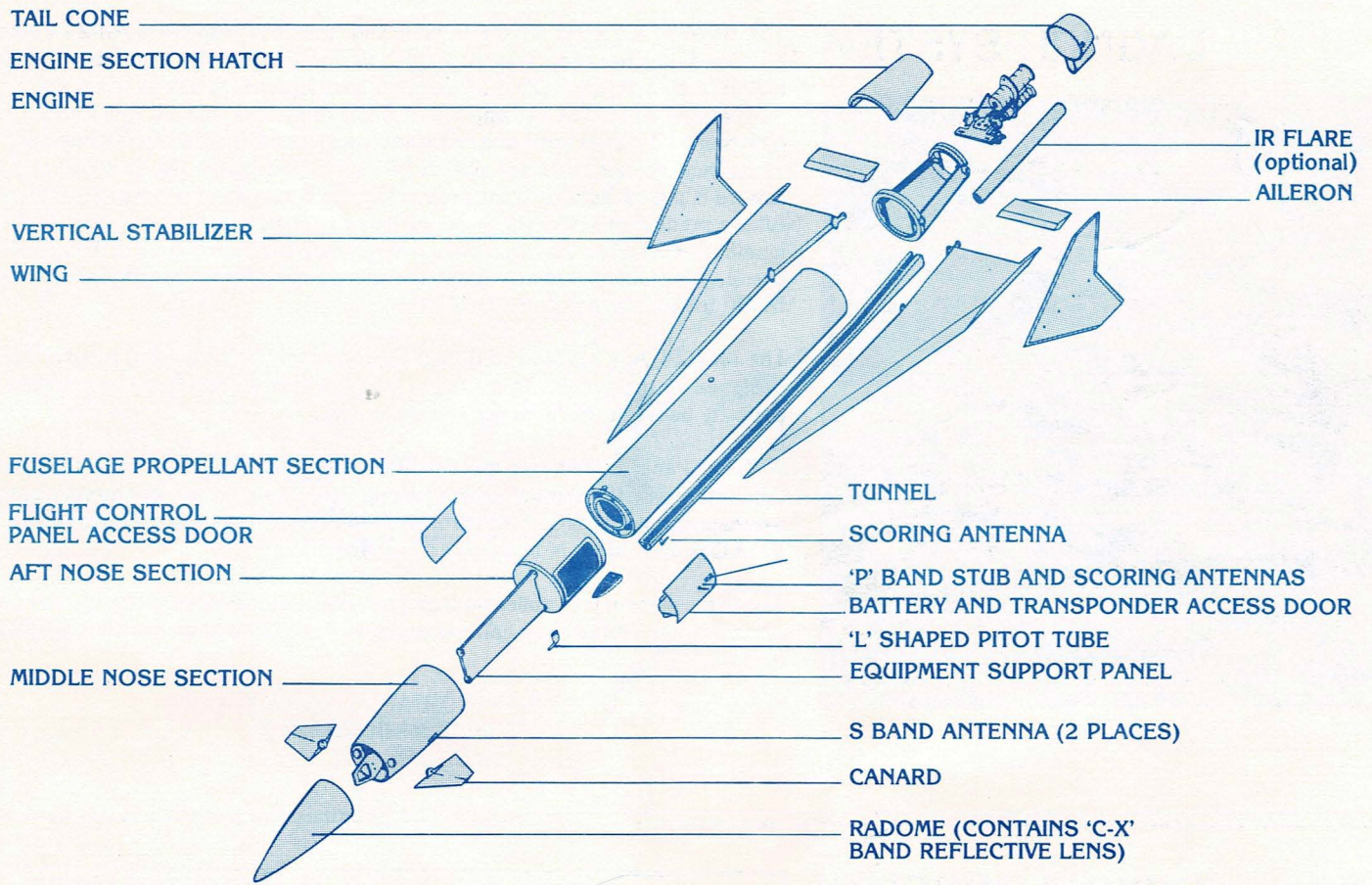

LAUNCH SYSTEM



The AQM-37A Target Missile is launched from the standard LAU-24A Airborne Ejection Launcher. The launcher which is compatible with a variety of aircraft is activated by a MK-9 MOD "O" launcher cartridge which drives a trapeze ejection mechanism downward causing target separation. The trapeze mechanism travels downward 12 inches providing sufficient forces to cause the target to separate from the launch aircraft in a level altitude. As the target leaves the launcher trapeze, a lanyard is pulled, activating the propulsion system pressurization and ignition cycle. After a predetermined delay to assure safe separation from the aircraft, final motor ignition occurs. This system is highly reliable and has been utilized in the launching of over 2,000 AQM-37A missile targets at speeds and altitudes ranging from Mach .6 at 5,000 feet to Mach 1.5 at 55,000 feet.

The LAU-24/A is adapted to different type aircraft by a launcher adapter specially designed for the aircraft. This adapter provides both electrical and mechanical compatibility between the launcher and the aircraft.

A Firing Panel is installed in cockpit of the launch aircraft. This firing panel is compatible with the standard aircraft wiring. The Missile Firing Panel is packaged to fit into each individual aircraft and provides selection and system indication lights when the AQM-37A target is attached to the launcher.

The entire system is installed without permanent modification to the aircraft and the aircraft can be returned to a combat configuration in 30 minutes by the removal of this equipment.

TYPICAL MISSION



The AQM-37A target missile can be launched by any standard land or carrier based military fighter, bomber, or attack aircraft with the proper adapter.

In the United States, the F-4, A-4, and F-8 have been qualified to carry and launch this target.

Also, AQM-37A can be carried in single or multiple loads. The multiple carriage provides wide flexibility and economy of operation.

Launch aircraft with mounted AQM-37A:

1. McDonnell Douglas F-4 Phantom
2. McDonnell Douglas A-4 Skyhawk
3. Chance Vought F8U Crusader

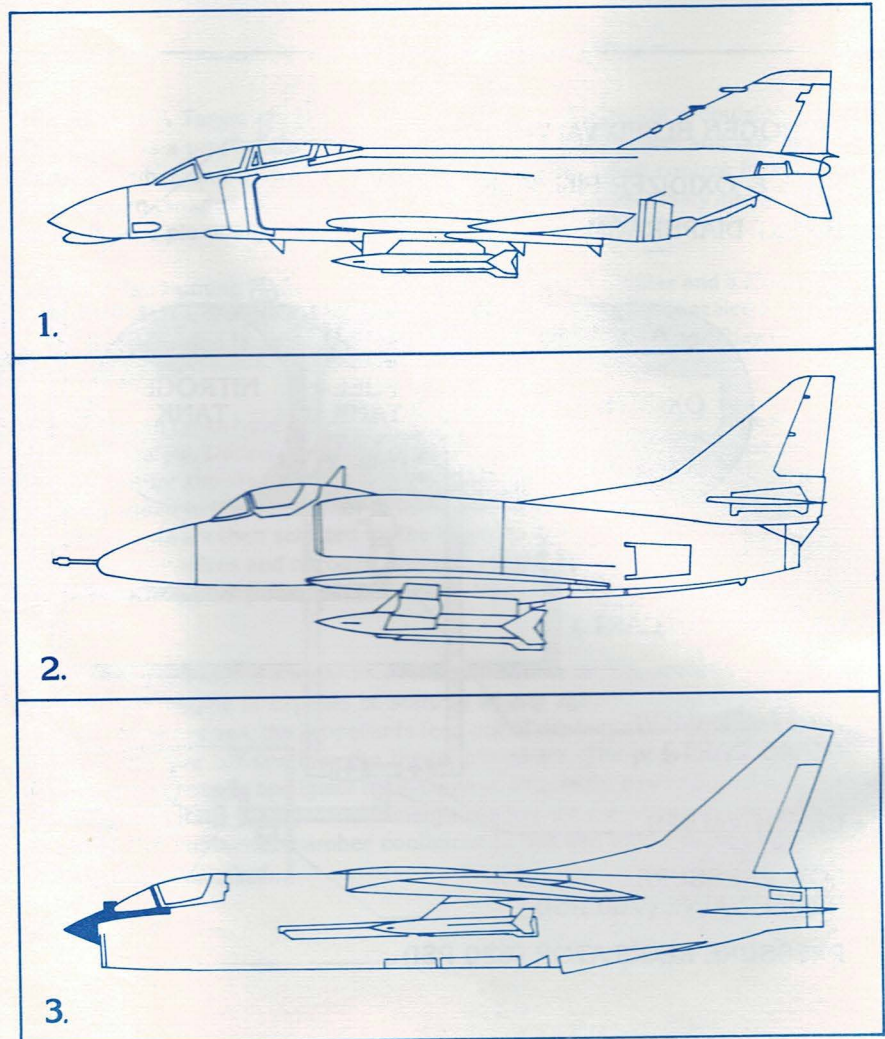

NOTE

LAUNCHER SHOWN IN EXTENDED POSITION

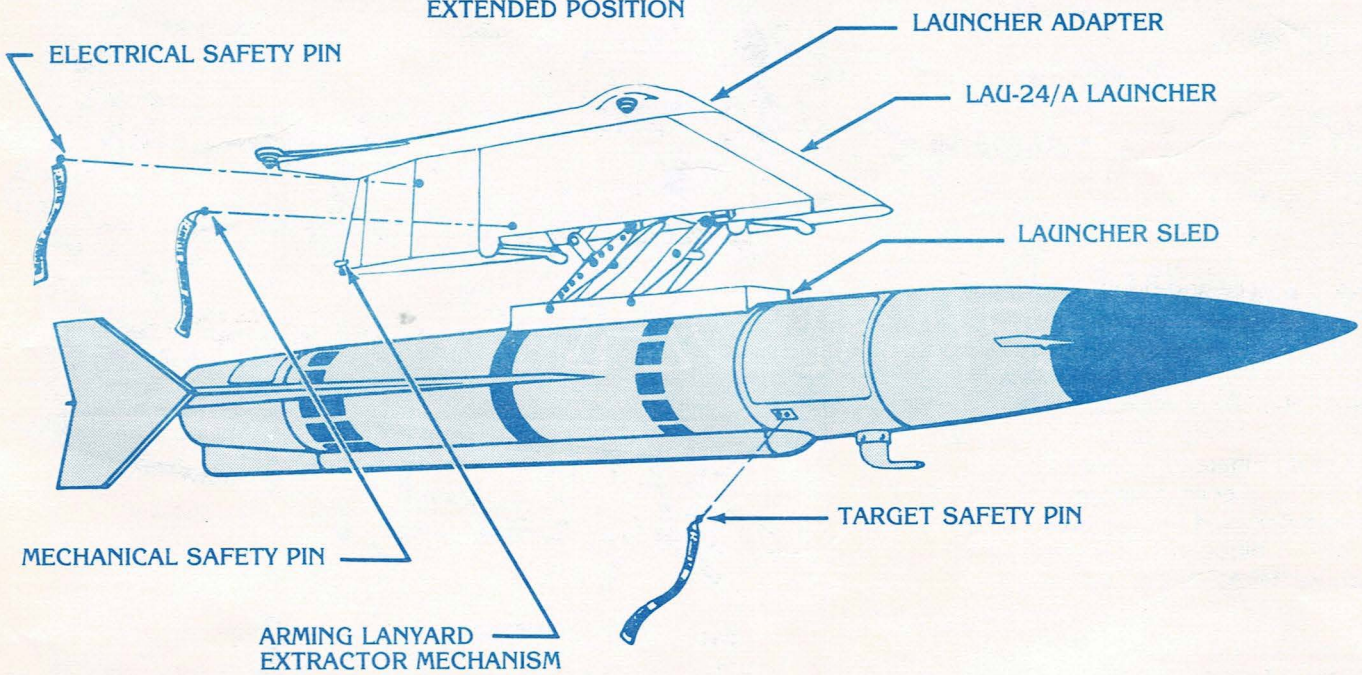

MACH 3.5 AT 100,000 FT. ALT.

MACH 3.0 AT 85,000 FT. ALT. (modified target)

MACH 2.0 AT 70,000 FT. ALT.

MACH 1.8 AT 50,000 FT. ALT.

HIGH ALTITUDE MISSIONS

--- PROJECTED
= DEMONSTRATED

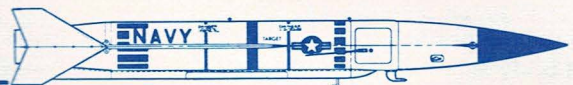

LOW ALTITUDE MISSIONS

MACH 1.5 AT 35,000 FT. ALT.

MACH 1.3 AT 20,000 FT. ALT.

MACH .95 AT 5,000 FT. ALT.

MACH .87 AT 1,000 FT. ALT.

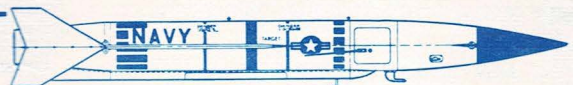

GROUND HANDLING EQUIPMENT

The AQM-37A and is handled and loaded on the aircraft with a minimum of equipment and personnel. Only two or three men are required to load the target aboard the aircraft. Maximum use can be made of existing equipment in the interest of economy. The target missile can be transported on any of numerous standard missile and bomb skids and trailers available at most military installations. Adaption of the AQM-37A shape to standard skids and trailers is accomplished by a universal cradle adapter. This cradle adapter supports the target at designated hardpoints and is used during checkout, ground transportation, and aircraft loading. Prior to launch, a nitrogen cart is required to pressurize the AQM-37A vehicle.

1. Universal Adapter
2. AQM-37A Shop Stand

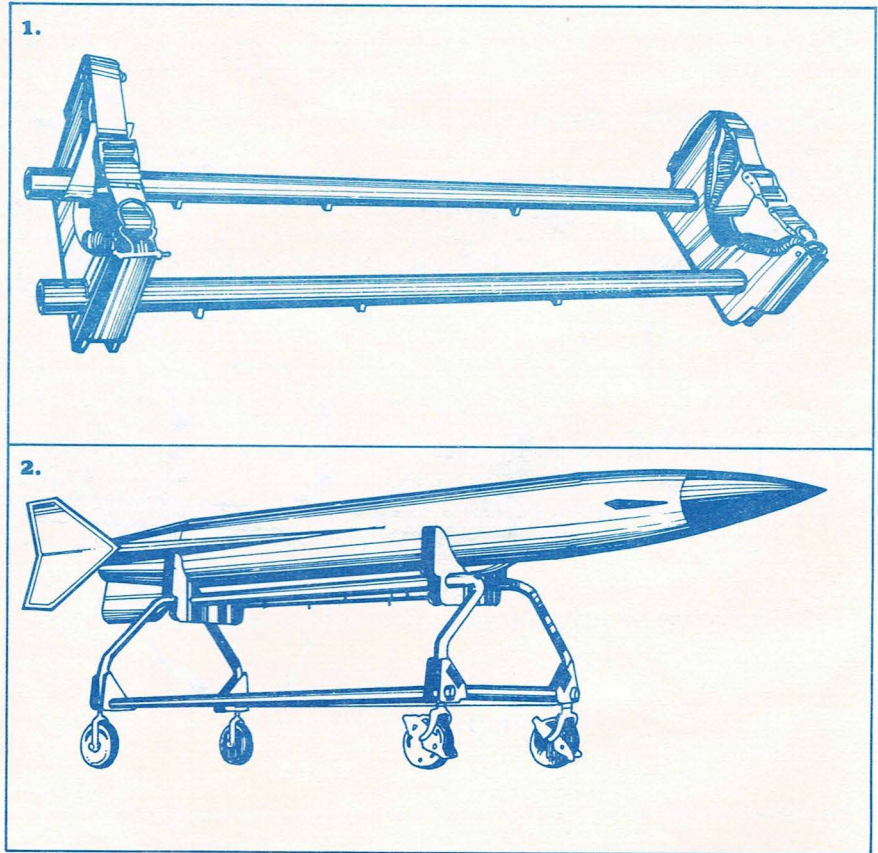

SHIPPING CONTAINERS

The complete operational missile target system may be shipped to any point in the world through the utilization of four containers.

The body of the target missile is shipped fully fueled in the body container. As a safety device, this container is equipped with indicators which will sense propellant leaks. A known atmosphere is imposed on the target body after it is sealed in the container and desiccants are packaged with the target to absorb moisture if the shipping container should leak. No special tools are required since all fasteners and latches are hand operated. The body removal required the use of a specially designed strongback hoist beam and a hoist of 1,000-pound capacity.

Wings, fins, and canards are shipped in a specially designed container. Batteries are shipped in a separate container.

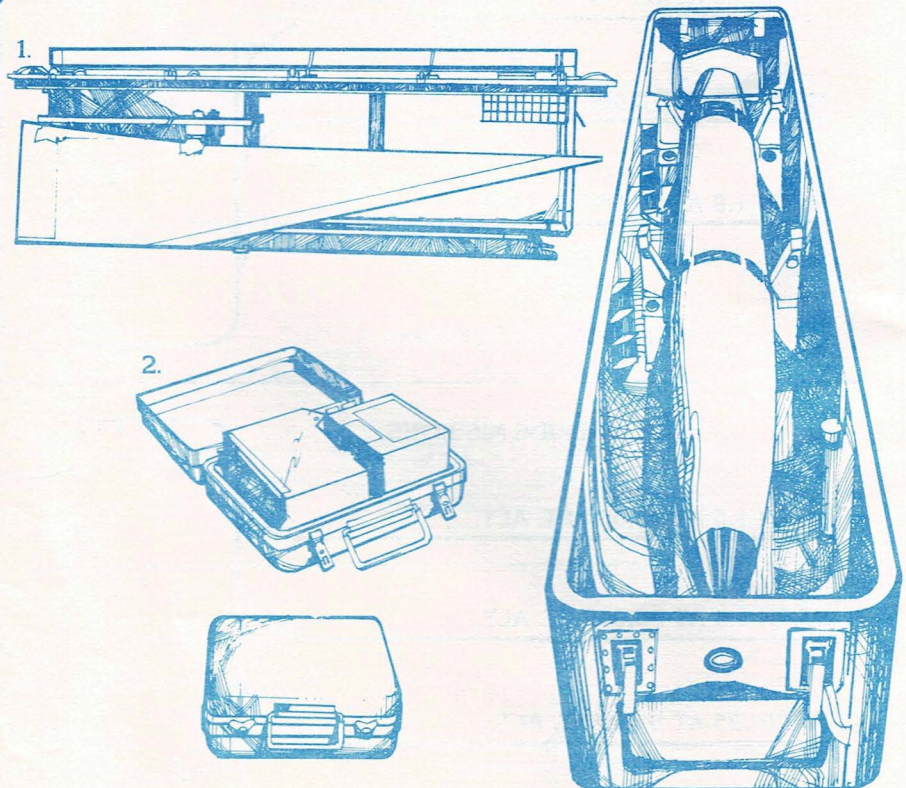

Above: Open View of Body Container
From Left Side of Page: 1. Body Container with Top in Place 2. Battery Container

Graphics & information for this booklet was extracted from publications of the AQM-37A manufacturers, and Jane's Pocketbook of Remotely Piloted Vehicles.

PARTS LIST KIT NO. 5342 - Magnum Jayhawk

Quantity	Description	Type	Number	Details1	Details2	Details3	Details4	Comment
1	PLASTIC NOSE CONE	PNC-80K	71035	9.75" long	2.600" dia.	1" shoulder	Secant-Ogive	Blow molded
1	PLASTIC NOSE CONE	PNC-20	72070	1.5" long	.736" dia.	.5" shoulder	Fits BT-20	Centuri PNC-70
2	PAPER BODY TUBE	BT-80A	30429	9" long	2.560" ID	2.600" OD	0.021" wall	
1	PAPER BODY TUBE	BT-50KE	30364	15" long	0.950" ID	0.976" OD	0.013" wall	
1	PAPER BODY TUBE	BT-20	30316	18" long	0.710" ID	0.736" OD	0.013" wall	
2	STAGE COUPLER	JT-80C	30274	2.50" ID	2.55" OD	1" long	fits BT-80	
1	Dummy Engine Casing - "D"		35012	2.75" long	.945" OD			
1	CENTERING RING	AR-2050	30164-2	1/4" long	.737" ID	.949" OD	0.106" wall	Green
1	ENGINE HOLDER	EH-2	3141/35025	2.8" long	.100" wide	.025" thick		Reg. & D
1	LAUNCH LUG	LL-3?	38781	7/32" ID	3/16" rod	1" long		
1	Shock Cord	SC-2?	85786	1/4" wide	24" long			Elastic
2	Parachute	PK-20	?	20" dia.				Centuri CP-20
2	Shroud Line	SLT-160		160"				
16	Tape Disc	TD-3	2298	1/2" dia.				
2	BALSA FIN STOCK	BFS-30	3168	3/32" thick	3" wide	9" long	Rudders	Scan
2	BALSA FIN STOCK	BFS-40W	32146	1/8" thick	4" wide	18" long	Wings	Scan
1	Thin Die-cut sheet		32964	.012" .3mm thick	4" wide	18" long	67 lb cardstock	Scan
1	Thick Die-cut sheet		32965	.055" 1.4mm thick	3" wide	18" long	Ring Stock	Scan
1	Boat tail Die-cut sheet		32966	.012" .3mm thick	6" wide	9" long	67 lb cardstock	Scan
2	NOSE CONE WEIGHT	CB-M4	85264	1" wide	1" high	1/2" thick	.5 oz.	CLAY
1	DOWEL	WD-1?	85901	1/8" dia.	12" long			Wood
1	Piano Wire	?	38295	8" long	.028" dia.	Steel		
1	Decal	KD-5342A	36862	6" long	2.5" wide	Red, Wht, Blu	waterslide	scan
1	Decal	KD-5342B	36863	18" long	4.5" wide	Blk, Brn, Grn	waterslide	scan



LOADED WITH DETAIL!

THIS IS ONE OF THE MOST HIGHLY DECALED MODEL ROCKET KITS EVER!

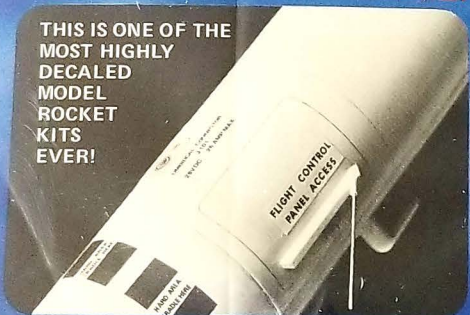

YOU WILL NEED:

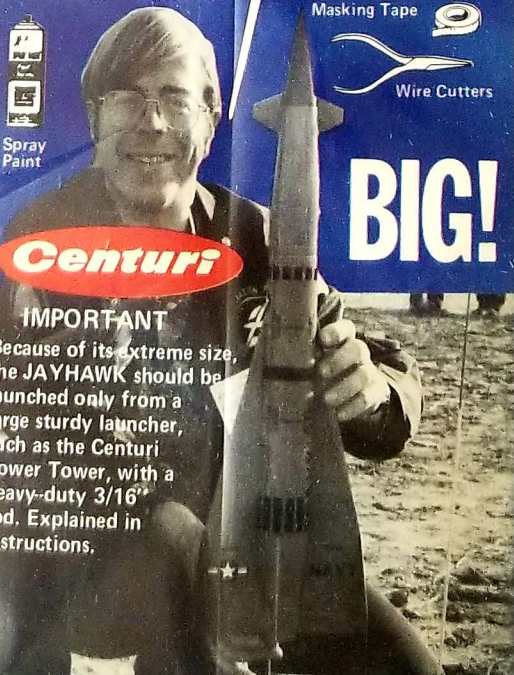

Centuri

BIG!

IMPORTANT

Because of its extreme size, the JAYHAWK should be launched only from a large sturdy launcher, such as the Centuri Power Tower, with a heavy-duty 3/16" rod. Explained in instructions.

MAGNUM-D JAYHAWK

RECOMMENDED ENGINE:
(Not included) D12-3

SPECIFICATIONS:
Length 30.4" (77.22cm)
Diam. 2.6" (6.6 cm)
Net Wt. 9.21oz (261g)



SPECTACULAR:
Big 1/5 scale model of Navy missile!

BIG! OVER 30" LONG!

CHALLENGING:
Designed for advanced model rocketeers!

COLOR DECALS:
2 big decal sheets in the 6 official colors!

PRE-CUT PARTS:
4 big balsa sheets, 3 different files!

DUAL CHUTES:
2 huge 20" chutes assure soft recovery!

INCLUDES BIG SCALE DATA BOOKLET
BONUS
ABOUT THE REAL JAYHAWK

RECOMMENDED FOR AGES 10 TO ADULT

FLYING MODEL ROCKET KIT
Hobby kit requiring assembly. Paint, tools and glue, not included.

ASSEMBLED LENGTH 30.4" (77.2 cm)

#5342

SKILL LEVEL
1 2 3 4 5
Beginner Intermediate Advanced

Centuri



AQM-37A IN ACTION!



BONUS:
INCLUDES FREE SCALE DATA BOOKLET

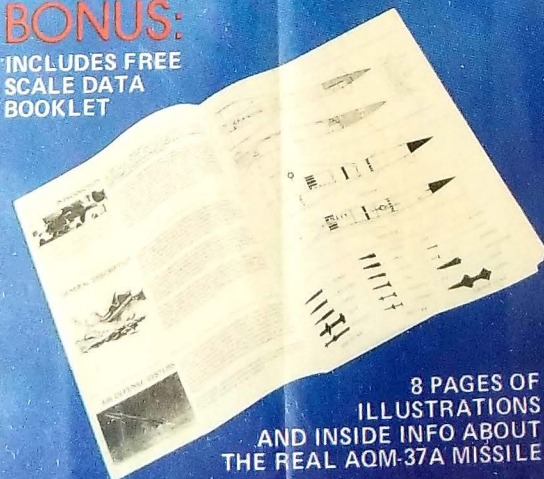

8 PAGES OF ILLUSTRATIONS AND INSIDE INFO ABOUT THE REAL AQM-37A MISSILE

The Centuri Magnum-D JAYHAWK was developed with the help of Chris Pocock and Doug Frost, two of the most expert Jayhawk scale modelers. Their research, scale data and field-testing helped make this great kit.

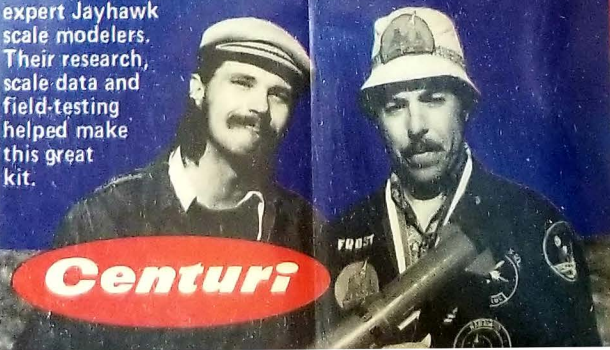

Centuri