

McKIBBIN'S SPECIAL

SKILL LEVEL 3

March 1982 Winner
Mike McKibben
Richland, WA

EXPLODED VIEW

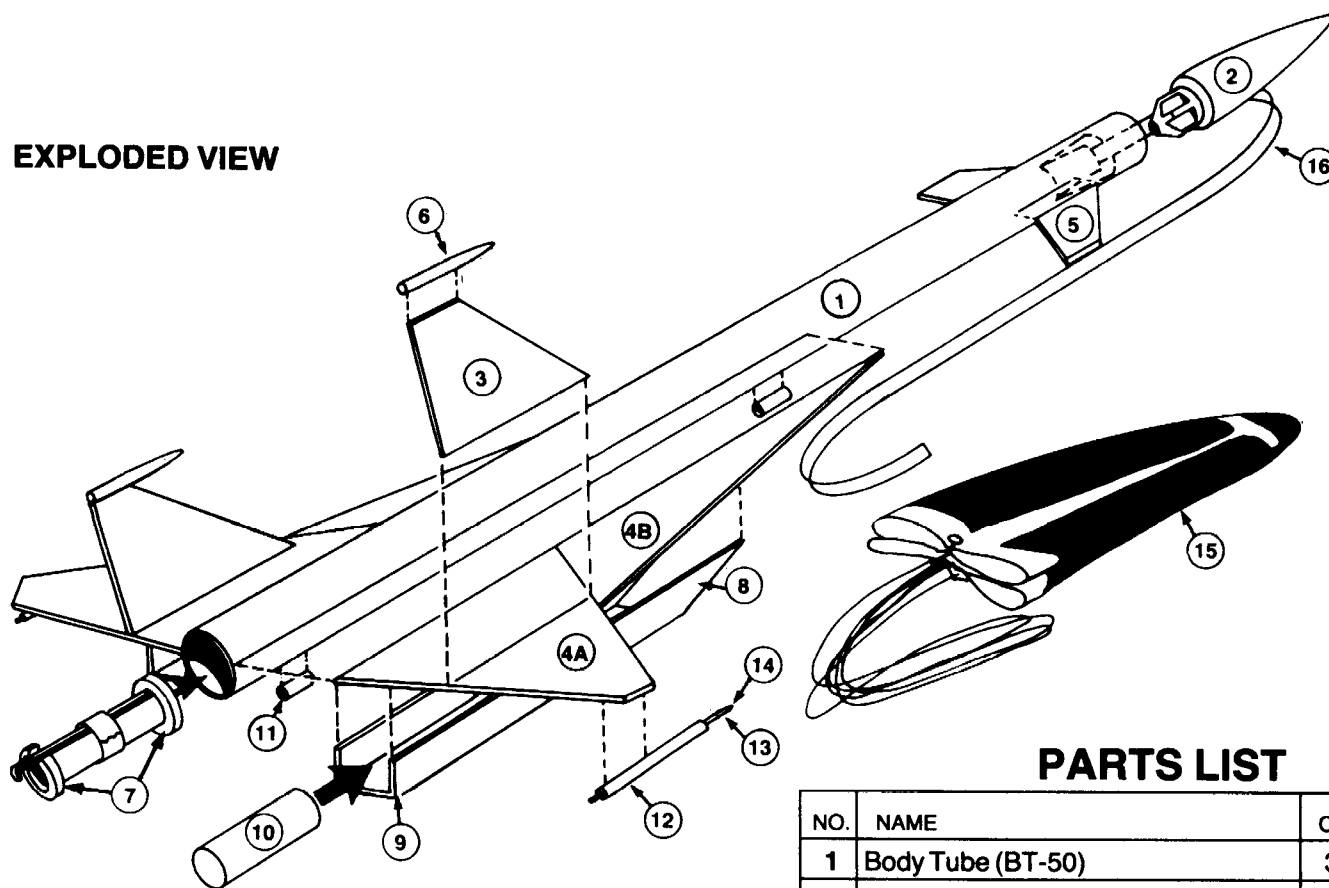

PARTS LIST

NO.	NAME	CAT. NO.	QTY.
1	Body Tube (BT-50)	30352	1
2	Nose Cone (PNC-50Y)	71009	1
3	Rudder (BFS-40L)	32118	2
4A	Wing (BFS-40L)	32118	2
4B	Wing (BFS-40L)	32118	2
5	Canard (BFS-30)	32108	2
6	Rudder Dowel 1/8"	32056	2
7	Engine Mount (EM-2050)	3154	1
8	Engine Side (BFS-30)	32108	4
9	Engine Bottom (BFS-30)	32108	2
10	Engine End (BT-5) 1 1/2"	30302	2
11	Launch Lug 1/8" (cut in 1/2" lengths)	2322	2
12	Launch Lug 3/16"	2328	2
13	Launch Lug 1/8"	2322	2
14	Dowell 1/8"	32056	2
15	PK-18	2267	1
16	Shock Cord 1/8", 18" Long	2276	1
17	Shock Cord Mount		1

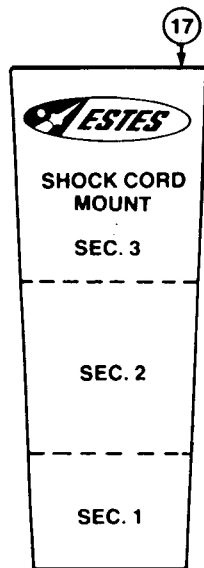

Recommended Engines:
B4-2 (first flt), C5-3, C6-3.

Additional Materials:

White glue, sanding sealer, spray paint, sandpaper, hobby knife, ruler and a sharp pencil.

DO NOT GLUE NOSE CONE IN PLACE

TOP VIEW

BOTTOM VIEW

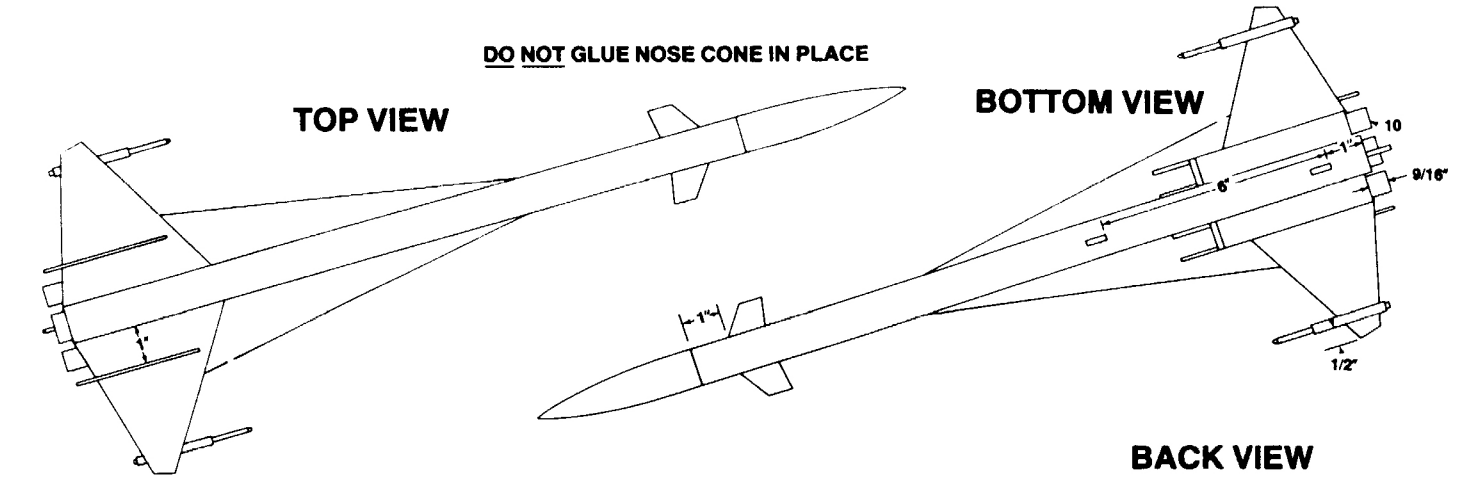

SIDE VIEW

BACK VIEW

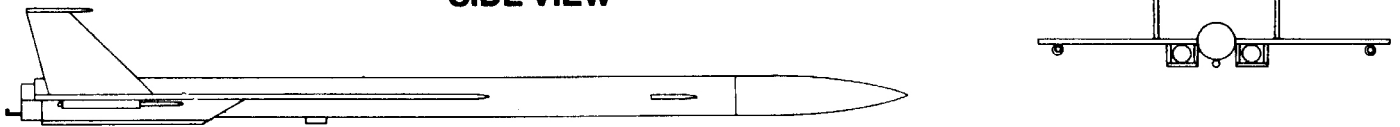

BT-50

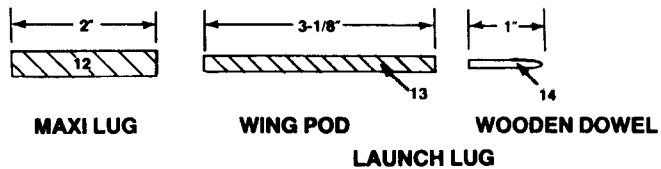
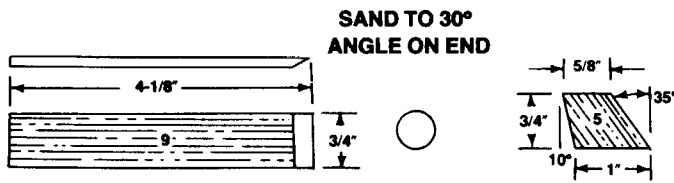
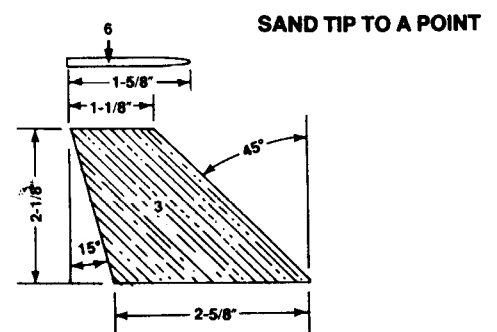
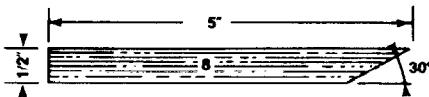
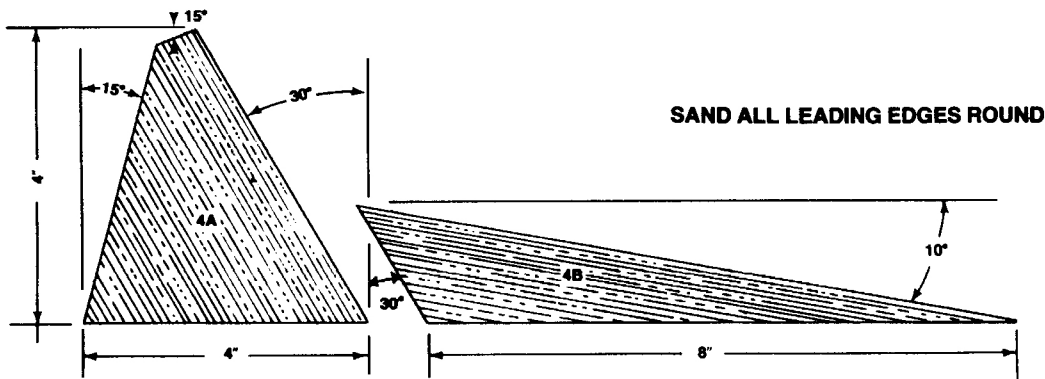

MAXI LUG

WING POD

WOODEN DOWEL

LAUNCH LUG

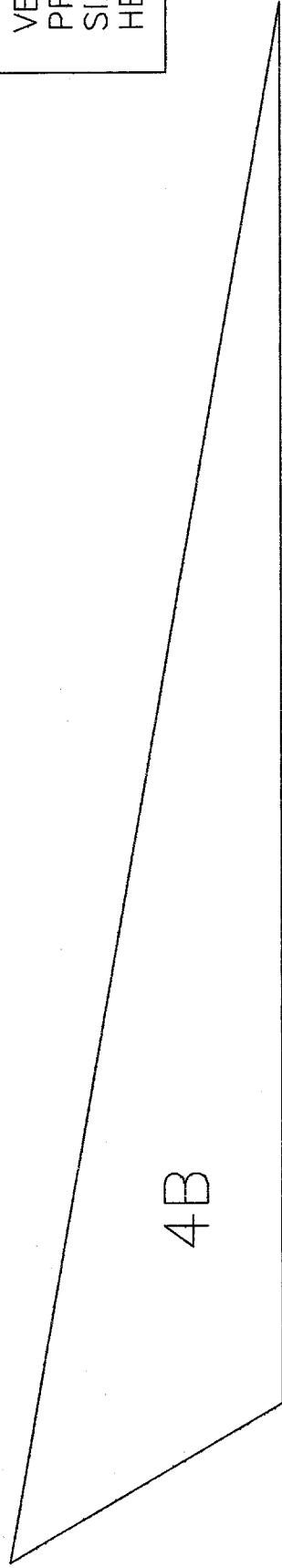
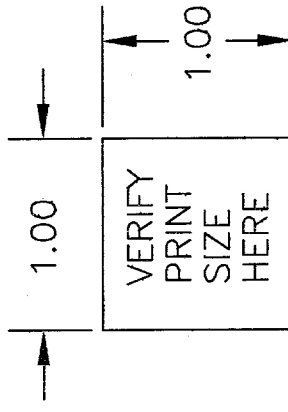
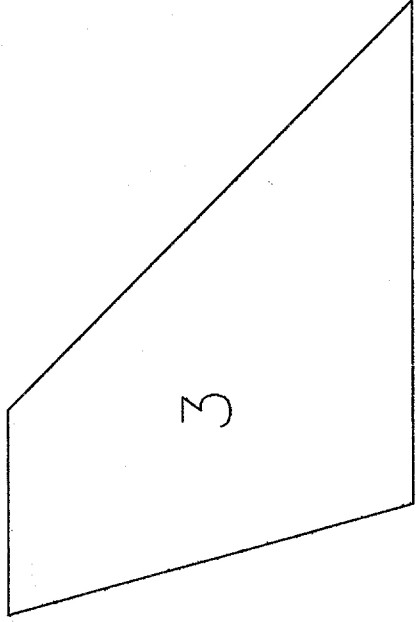
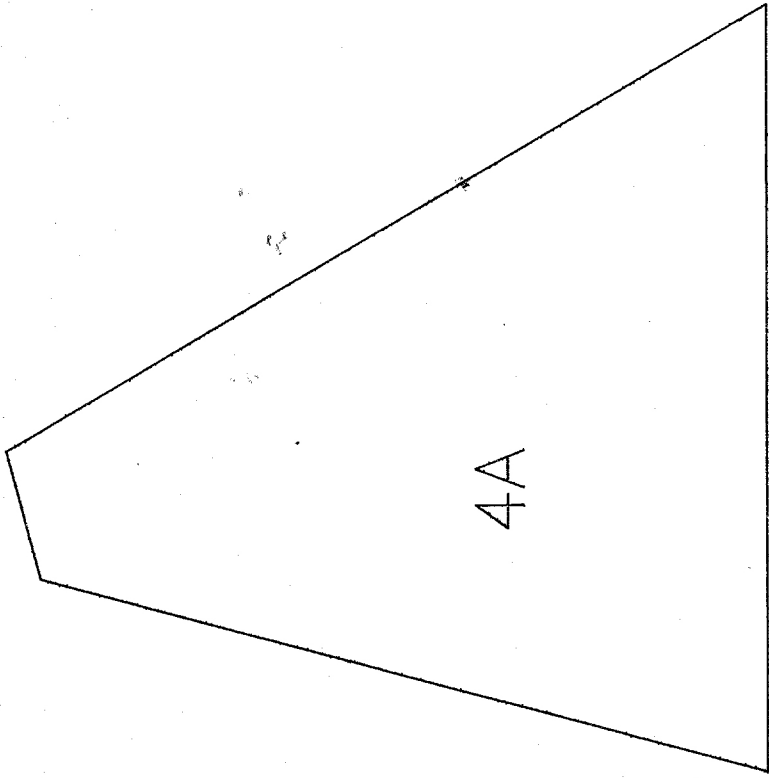

FULL SIZE TEMPLATES - MCKIBBIN'S SPECIAL
DRAWN BY JIM STUCKMAN 9/25/98