

Estes Industries Rocket Plan No. 20

MINI-X

2-Stage Payload Rocket

Published as a service to its customers by Estes Industries, Inc., Box 227, Penrose, Colorado. ©Estes Industries, 1964

Assembly Instructions

Apply glue to the last 1/4" of the inside of the 3-1/2" long booster tube. Insert an engine block and push it forward until the end of the engine block is even with the end of the tube. Select the two 20-50 rings from the adapter ring set (they should fit tightly around a BT-20 and tightly inside a BT-50). Glue one ring to each end of the JT-50C coupler. Set this assembly aside to dry.

Next mark the 3-1/2" long engine holder tube 11/16" from the end that does not have the engine block. When the ring-coupler unit has dried slide it onto the engine holder tube. The front ring should be exactly on the mark. Spread glue around both ring-tube joints. Wipe away any excess glue with your finger.

When the engine mount has dried completely smear glue around the inside of the 2-3/4" long booster body tube to cover an area 1" from one end. Insert the engine mount unit into this end of the body, engine block end first, until the engine block end is even with the bottom end of the booster body tube. Set this aside to dry.

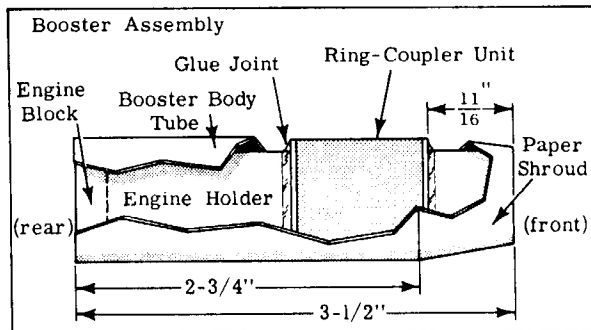

Wrap a layer of cellophane tape tightly around the joint of two rocket engines and slide them into the lower stage. Using your little finger or a brush, smear glue around the inside of the 6-1/2" long upper stage body tube to cover an area approximately 2" from one end of the body tube. Insert an engine block into the body tube and push it into place with the taped engines

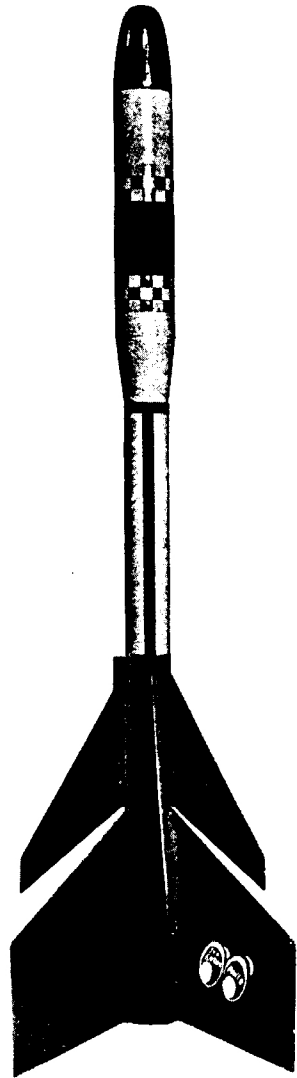

Parts List

| | |
|--------------------|-----------|
| 1 Nose Cone | #BNC-50J |
| 1 Body Tube | #BT-50S |
| 1 Balsa Adapter | #TA-2050A |
| 1 Screw Eye | #SE-1 |
| 1 Shock Cord | #SC-1 |
| 1 Parachute | #PK-12 |
| 1 Body Tube | #BT-20D |
| 2 Engine Blocks | #EB-20A |
| 1 Launching Lug | #LL-1B |
| 1 Body Tube | #BT-50J |
| 1 Body Tube | #BT-20G |
| 1 Stage Coupler | #JT-50C |
| 1 Adapter Ring Set | #TA-1 |
| Balsa Fin Stock | #BFS-20 |

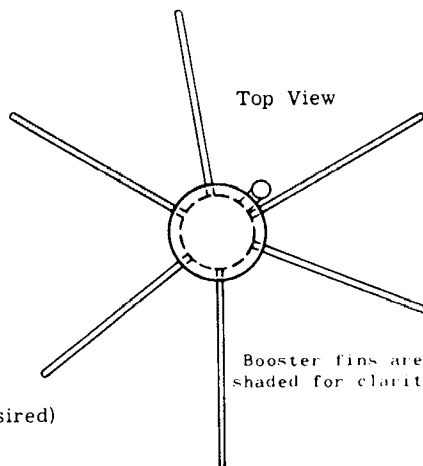
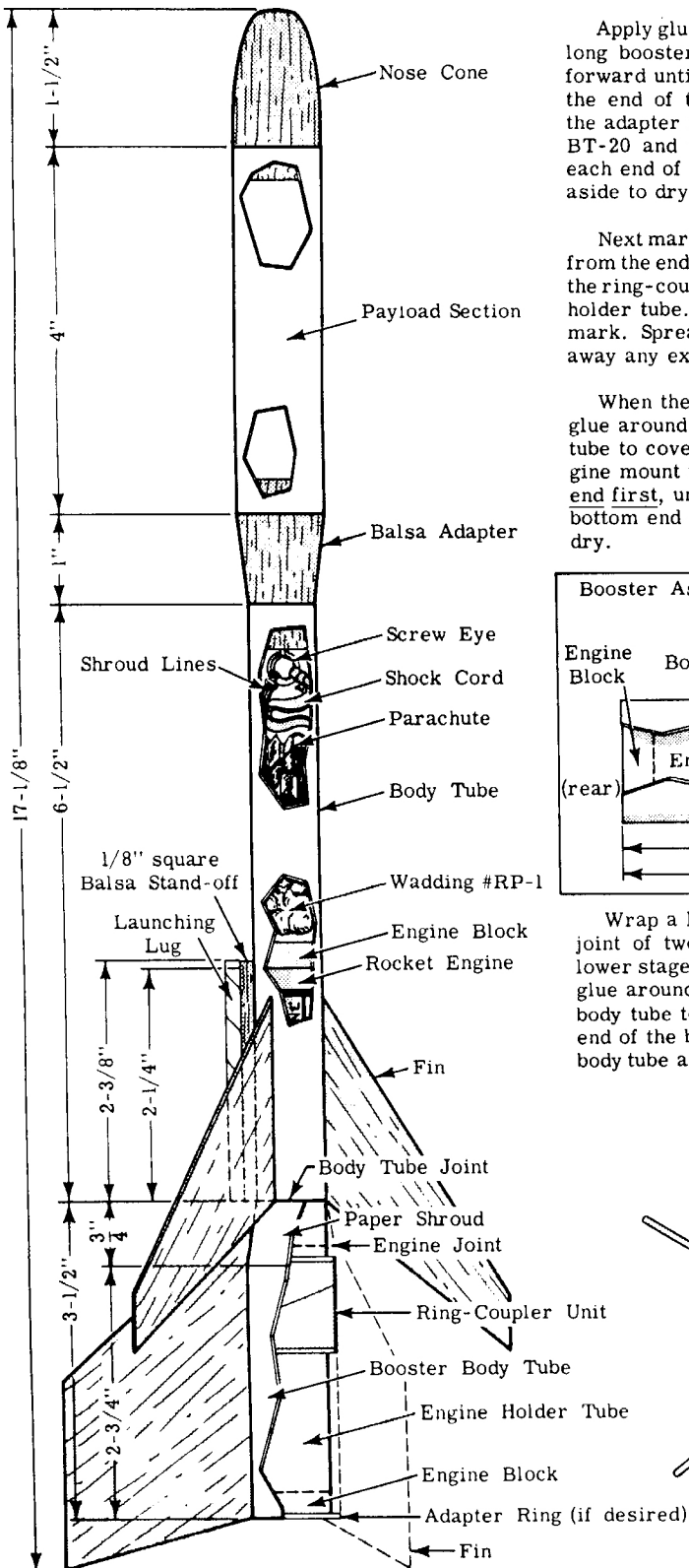

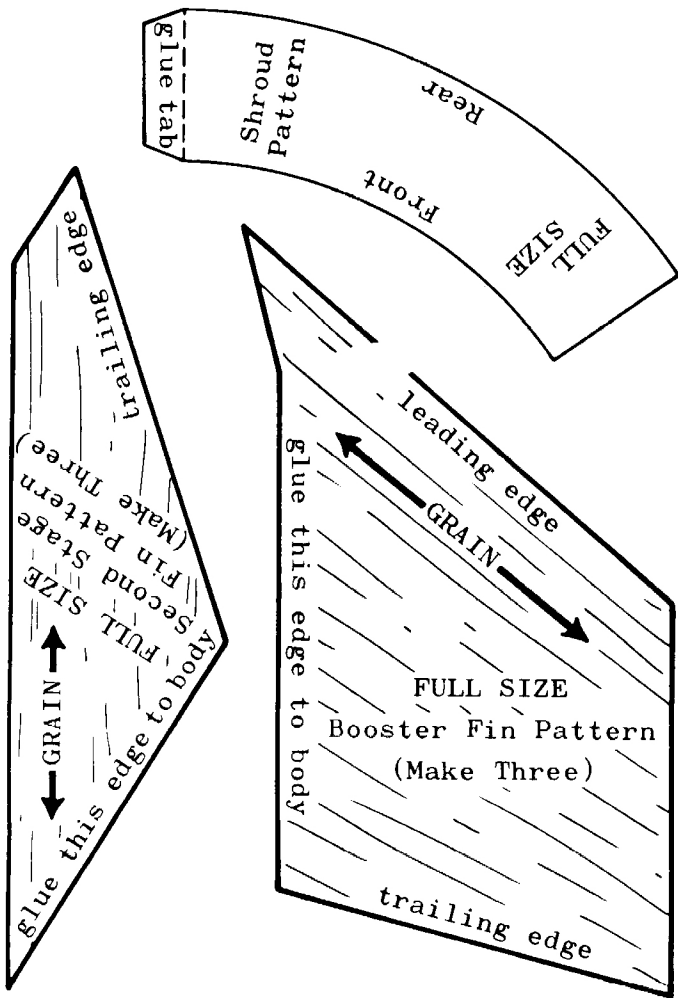

Trace fin patterns onto a separate sheet to preserve plans.

and the lower stage. Remove the engines immediately. (Another method of positioning the engine block is to mark an empty engine casing 2-1/4" from one end. Spread glue around the inside of the 6-1/2" body tube about 2" from one end. Insert an engine block and push it forward into the body tube with the engine casing until the mark on the casing is exactly even with the end of the body tube--and the engine block is 2-1/4" from the end of the body. Remove the engine casing immediately.)

Carefully trace the shroud pattern onto index paper or the heavy paper supplied in the adapter ring set. Cut out the shroud and form it to a conical shape. Apply glue to the tab and hold it in place with the joint exactly covering the tab area. When the glue has set slip the shroud onto the engine holder tube. Spread glue around the exposed part of the ring-coupler unit and slide the shroud up tightly against the booster body tube. Wipe away any excess glue.

Tapered Shroud Assembly

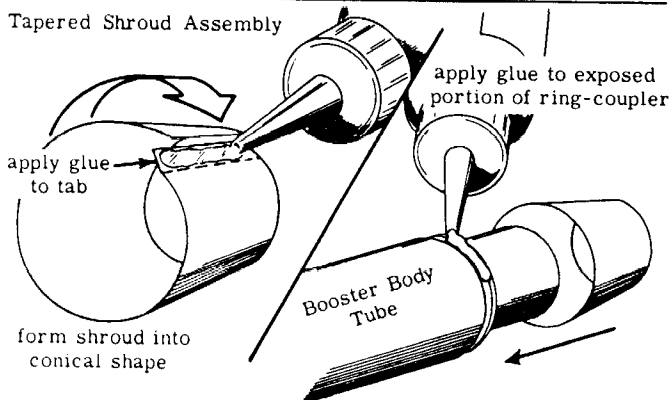

Glue the large end of the balsa adapter to one end of the payload section tube. The nose cone should fit tightly in the other end. If it is too loose wrap its shoulder with tape to increase the diameter.

Cut out three booster fins and glue them to the booster body tube. Match the grain on the balsa with the grain direction indicated on the fin pattern. Align each fin by sighting along the body and adjusting it until the fin is parallel to the body and projects straight away from it. When the glue has dried run a fillet of glue along each fin-body joint. Repeat this procedure with the three second stage fins.

Glue the launching lug to a 2-3/8" long piece of 1/8" square balsa. Glue the balsa to the second stage midway between two fins.

Attach the shock cord and recovery system as shown in the illustrations below.

Shock Cord Installation

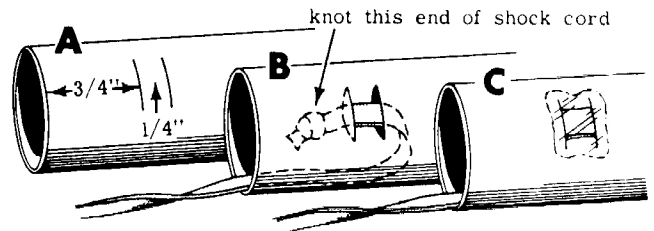

- Cut two slits 1/4" apart in the forward end of the upper stage body tube.
- Press in the section between the slits and thread the shock cord through the opening.
- Push the caved-in portion outward and seal with glue.

Attaching Recovery System

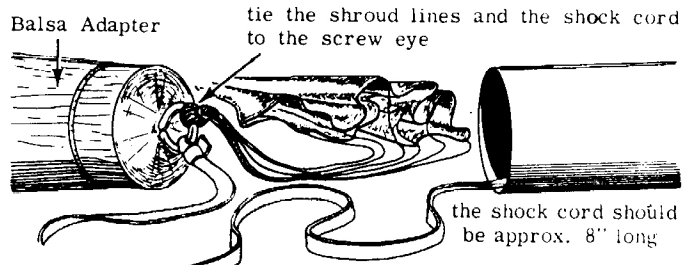

Paint the model and apply decals. Tape the upper and lower stage engines together with cellophane tape and secure tightly in the rocket as described in 'R-2' (published in the Feb. '64 issue of the *Model Rocket News*). These procedures must be followed or the rocket will not fly correctly.

Recommended Engines

| Upper Stage | | Lower Stage | |
|-------------|-----------|-------------|-------|
| 1/4A3-4 | 1/2A6-4 | 1/2A6-0 | A8-0 |
| A8-5 | A5-4 | B6-0 | B14-0 |
| B6-4 | B6-6 C6-7 | C6-0 | |

(Use 1/4A. engines for first flights.)

Use Series I and Series II engines only.

Suggested Engine Combinations

| | 1st Stage | 2nd Stage |
|--|-----------|-----------|
| Medium Altitude with light payload | 1/2A6-0 | 1/2A6-4 |
| Medium Altitude with 1/2 oz. payload | A8-0 | 1/2A6-4 |
| Medium Altitude with 1 oz. payload | A8-0 | A8-5 |
| High Altitude with light payload | B6-0 | B6-6 |
| Extra High Altitude with light payload | C6-0 | C6-7 |
| High Altitude with 1 oz. payload | B14-0 | C6-7 |

Other combinations of engines may be used to obtain desired flight performance.

(Maximum recommended payload weight is 1 oz.)