





- ① Top
- ② Cre
- ③ Sta
- ④ Sta
- ⑤ Lau
- ⑥ Port
- ⑦ Port

GENER

**PARTS LIST**

- |   |                    |         |
|---|--------------------|---------|
| 1 | Body Tube 16.35"   | BT-55V  |
| 1 | Body Tube 18"      | BT-5    |
| 1 | Nose Cone          | BNC-55F |
| 3 | Nose Cones         | BNC-5W  |
| 5 | Nose Cones         | BNC-5E  |
| 1 | Balsa Stock        | BFS-80  |
| 2 | Sheets Balsa Stock | BFS-40L |
| 1 | Wood Dowel 1/12"   | WD-2    |
| 1 | Launch Lug         | LL-2D   |
| 1 | Engine Mount       | EH-2055 |
| 1 | Engine Holder      | EH-2    |
| 1 | Screw Eye          | SE-2    |
| 1 | Shock Cord 36"     | SC-3    |
| 1 | Snap Swivel        | SV-12   |
| 1 | Parachute Kit 24"  | PK-24   |

Specify parachute color

**RECOMMENDED ENGINES**

- B4-2    B4-4    B6-4    C6-5

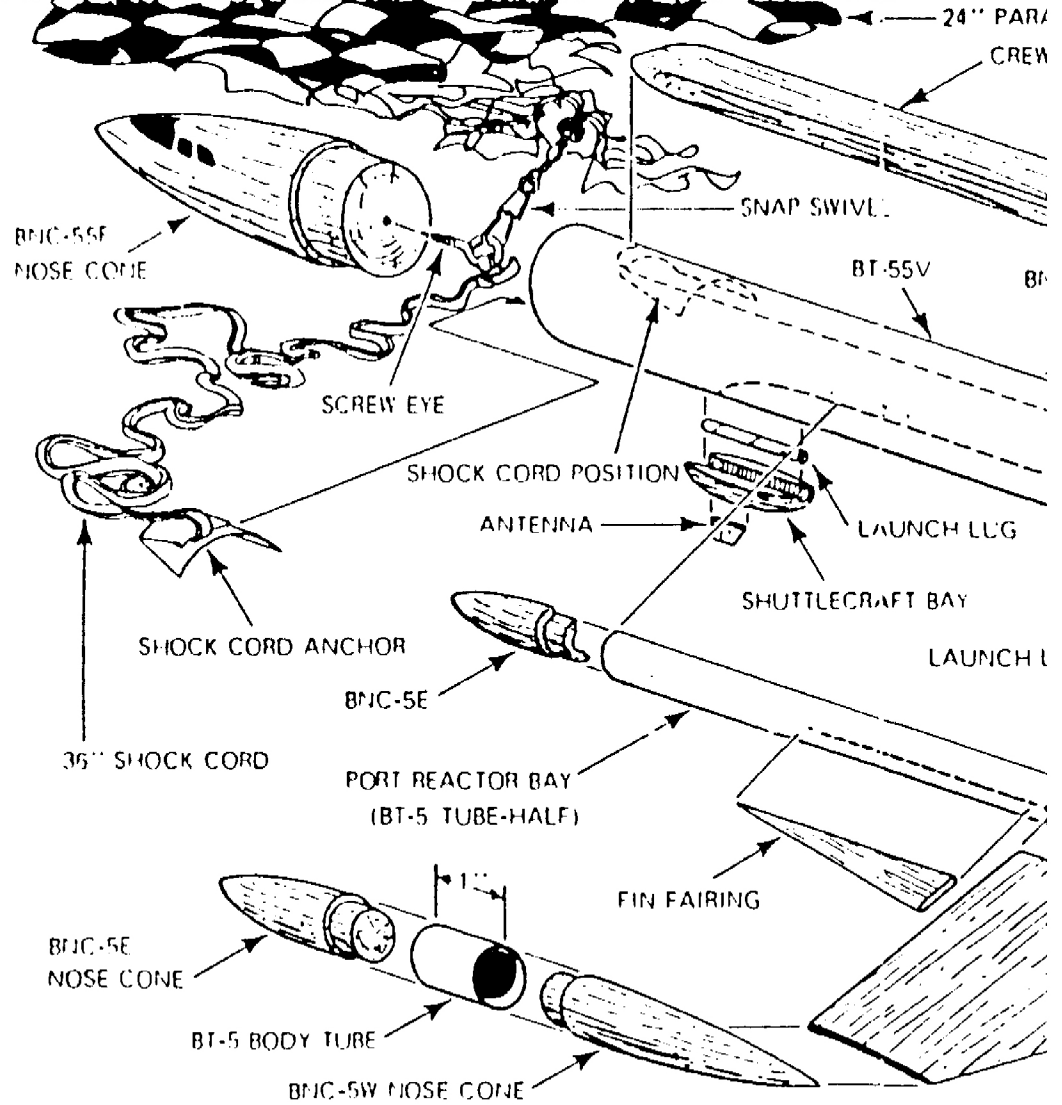

CREW MODULE



TYPICAL CROSS-SECTION

Front

**CREW MODULE PATTERN** — Top View



up Fin Alignment Line  
 Crew Module Centering Line  
 Starboard Reactor Bay Centering Line  
 Starboard Fin Alignment Line  
 Launch Lug Alignment Line  
 Port Reactor Bay Centering Line  
 Port Fin Alignment Line

**REAR VIEW**

Showing alignment and centering lines

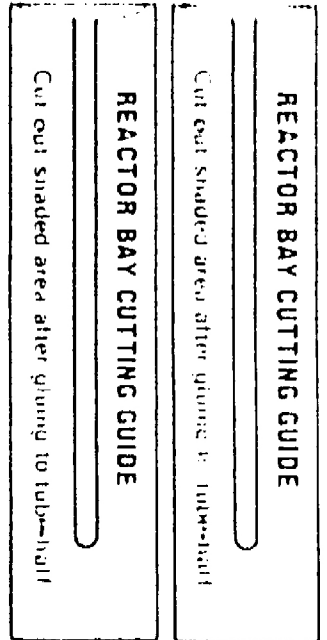
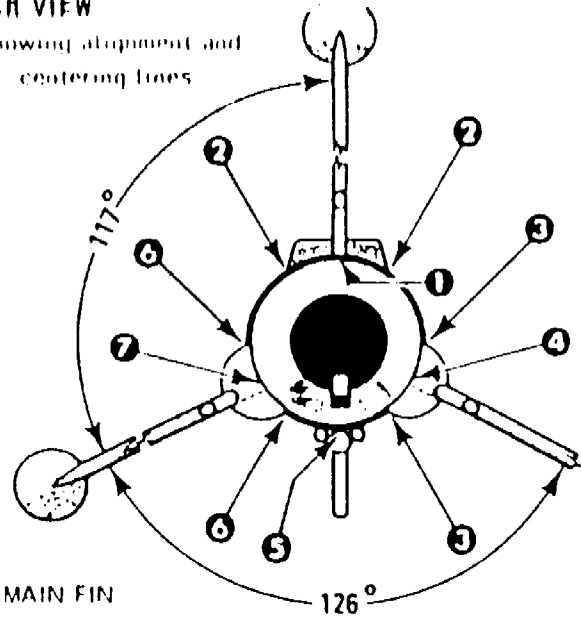

**GENERAL VIEW**

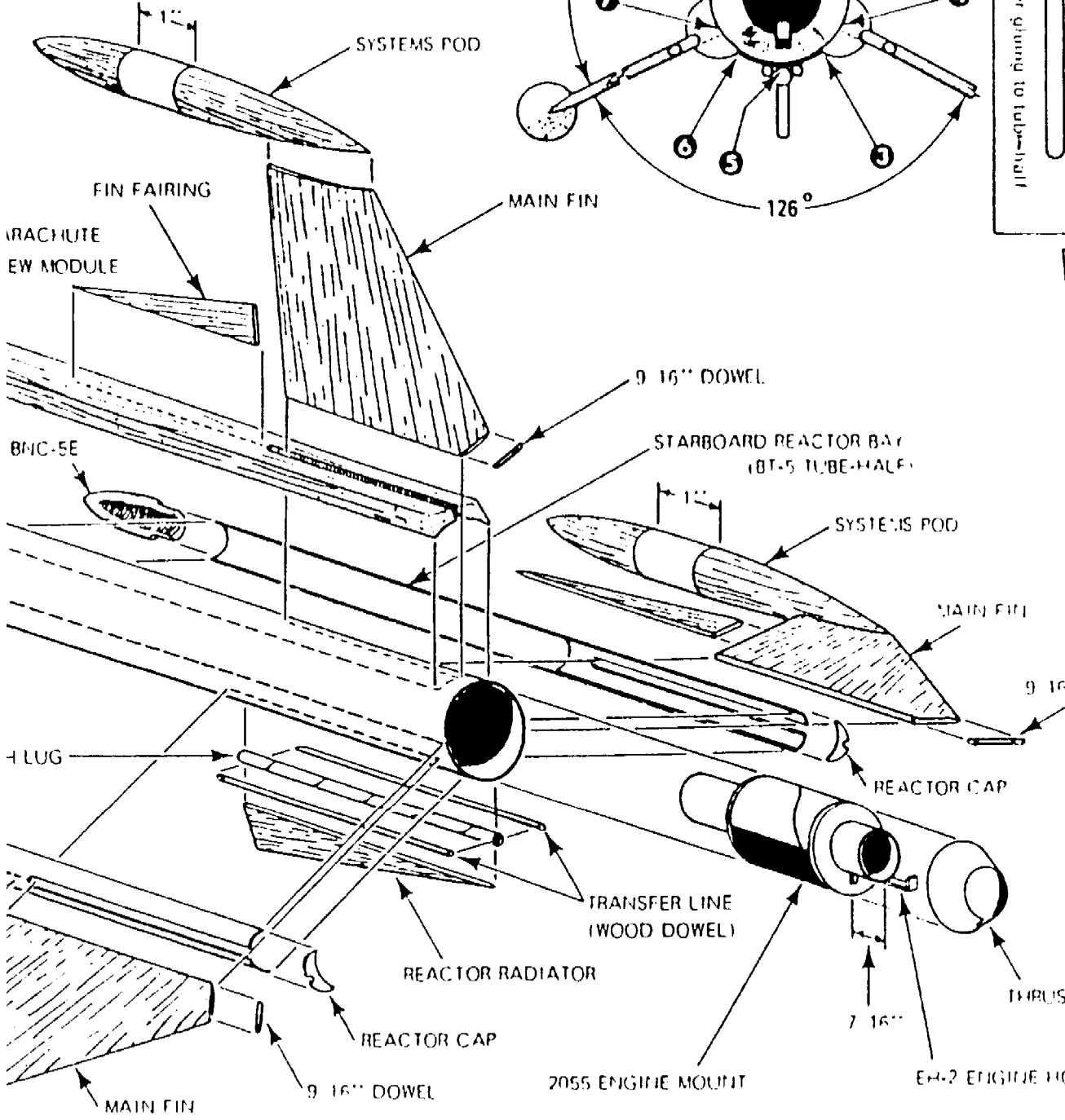

**SHOCK CORD ANCHOR**

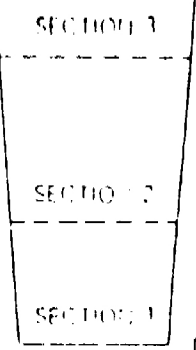

**DOWEL PATTERN**

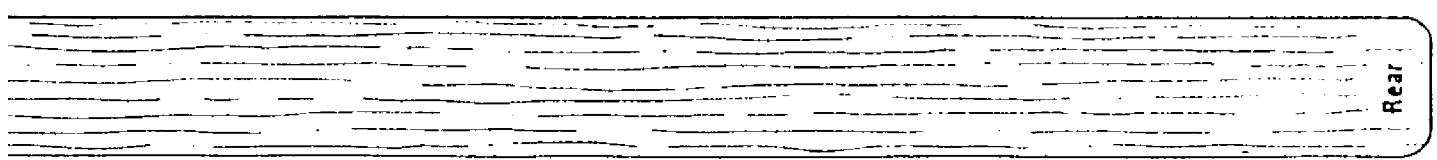

TRANSFER LINE PATTERN 1 1/2" Dowel

### 1 SYSTEMS POD ASSEMBLY

Cut three 1" lengths from the BT-5 body tube. (See "Construction Tips" and "Cutting the Body Tube" in your Estes catalog. These sections will help you in constructing your model.) Glue a BT-5E nose cone into one end of a 1" BT-5 body tube. Glue a BT-5W nose cone into the other end of this tube. Set the unit aside to dry. Assemble the two remaining Systems Pods in the same manner.

### 2 CREW MODULE CONSTRUCTION

Trace the Crew Module pattern onto the BT-80 halves. Cut and shape the piece as shown.

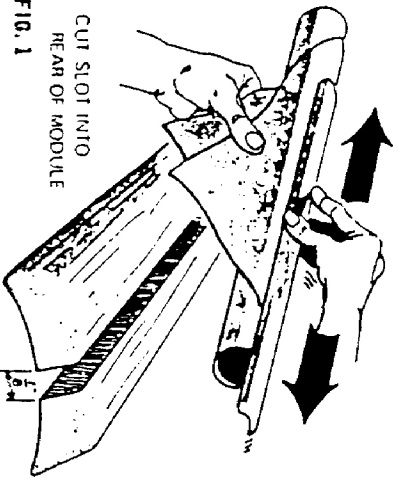

### CUT SLOT INTO REAR OF MODULE

FIG. 1

Carefully hollow its inside. Wrap a large sheet of fine sandpaper around the BT-55V body tube. Slide the module back and forth along the sandpaper until its bottom edges fit smoothly against the body tube (Fig. 1). Check the module's fit frequently as you sand. When the module is shaped and sanded, cut a slot 2-11/16" long and 1/8" wide in its rear as shown in the general view.

### 3 REACTOR BAY CONSTRUCTION

Cut a 10-1/4" length from the remaining section of BT-5 body tube. Cut out the BT-5 Marking Guide and wrap it around the body tube. Draw a line the length of the tube from arrows "A". From arrows "B" draw a line 7-1/2" long from one tube end. Carefully cut the Reactor Bay body tube in half along the two longest lines.

### CUT AWAY SHADED AREA OF NOSE CONE

HOLLOW OUT

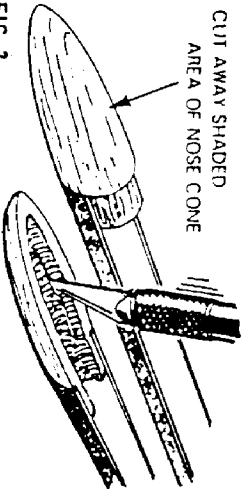

FIG. 2

Carefully cut two feet of Bay body tube to 1/4" along the lines. Glue a BT-5E nose cone into one end of a tube half. Glue another BT-5E nose cone into the other Reactor Bay body. Use masking tape to hold the cones in place and set aside until completely dry. Cut away the portion of the nose cone outside the body tube as shown in Fig. 2. Hollow the cones and sand as needed to fit smoothly alongside the BT-55 body tube. Use the same "back and forth" sanding method as you did with the Crew Module. Cut the Reactor Bay cutting guides from the plan sheet. Glue them to the inside of the Reactor Bay body tubes at the rear. Cut out the shaded area of the guides. This forms the fin slot and tapered end of the Reactor Bay.

### 4 BODY TUBE MARKING

Thread the screw eye into the nose cone, remove it, squirt glue into the hole and re-insert the screw eye. Cut the BT-55V marking guide from the pattern sheet. Wrap it around the body and hold in place with masking tape. Mark the tube at each arrow. Arrows 1, 4 and 7 require a line drawn 3-1/2" from the rear of the body tube. Arrows 2, 3, 5 and 6 require a line to be drawn along the entire body tube.

### 5 ENGINE MOUNT ASSEMBLY

Mark the EH-2055 engine mount tube 1/4" from one end. Cut a 1/8" slit into the engine mount tube on the mark as shown in Fig. 3. Slip one end of

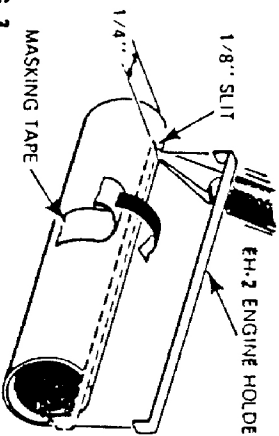

FIG. 3

the EH-2 engine holder into the slit. Hold the hook temporarily in place with a small strip of masking tape.

Cut a notch 1/8" square from the inside of one 2055 spacing ring. Spread a line of glue around one end of the stage coupler. Place a spacing ring on and wipe away any excess glue. Glue the other ring on the other end of the stage coupler. Set aside to dry completely. You may wish to assemble the parachute and shock cord mount while the glue dries. Mark the engine mount tube 7-1/6" from the rear. Remove the masking tape from the tube. Slide the engine mount tube and engine holder into the stage coupler (See General View). Set the notched ring on the 7/16" mark. Be sure the engine holder runs straight along the engine mount tube. Center the spacing ring notch over the engine holder. The rear of the engine holder should move freely up and down in the notch. Run a fillet of glue around the forward ring-engine tube joint. Apply a glue fillet around

the rear ring-engine tube joint, except at the spacing ring notch. Let this assembly dry completely. When it is dry, spread a layer of glue inside the BT-55V body tube about 1" inside from the end. With one smooth motion, slide the engine mount assembly into the body tube. Position the rear spacing ring 1-1/6" inside the BT-55 body tube. Run a fillet of glue around the body tube-engine mount joint. Cut out the Thrust Cone and glue it together. Run a line of glue around the inside edge of the small thrust cone opening. Slide the cone into place, centering the notch over the engine holder. The thrust cone fits just inside the BT-55 body tube. Run a fillet of glue around the BT-55 body tube-thrust cone joint.

### 6 FIN ASSEMBLY

Trace the fin pattern onto the BT-50L fin stock. Cut out three fins and sand to shape as shown. Glue the fins to the BT-55V body tube along the fin alignment lines. Position the rear of each fin 1/4" forward from the rear of the body tube. Let each fin dry before attaching the next. When all three joints are dry, apply a glue fillet to both sides of each fin. Cut three 9/16" lengths from the WD-2 wood dowel. Sand to shape as shown. Glue these to the fin trailing edges as indicated on the fin pattern.

### 7 MAIN ASSEMBLY

Test fit the hollow Crew Module onto the body tube, checking the fit of the fin slot. Glue the Crew Module into place, centering it along the body tube marking lines. Use masking tape to hold it until dry. Test fit both Reactor Bay sections. Glue them into place one at a time. Use short strips of masking tape to hold the Reactor Bay along the BT-55 body tube centering lines. Cut out the Reactor Bay Caps and glue them onto the rear of the reactor bays. Trace 3 fin fairings on the BT-50L fin stock. Cut them out and sand to shape as shown. Glue the first fin fairing onto the crew module top against the large fin. Glue the two remaining fin fairings onto the Reactor Bays against the fin and along the fairing centering lines.

Give the Systems Pods onto the fin tips. Slightly align each pod and hold in place with masking tape until dry. Run a glue fillet along each fin-pod joint.

### 8 FUSELAGE DETAILING

Cut a 1-1/2" length from the LL-2D launch lug. Glue this lug in position 1-3/8" from the forward end of the body tube and on the number 5 (see Rear View) alignment line. Cut a 4" length from the LL-2D launch lug and glue it on the number 5 line flush with the body tube rear.

Cut out the Shuttlecraft Bay pattern and trace it twice onto a scrap of BT-580 halves. Cut out the pieces and glue them together as shown in Fig. 6A. When this part is completely dry, sand the upper surface to fit smoothly beneath the rocket body tube.

CUT THE LAUNCH LUG

SAND TO FIT UNDER THE

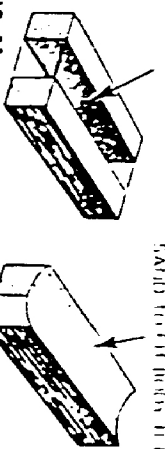

FIG. 6A

Cut a groove for the launch lug and sand to shape as in Fig. 6B. Glue into place over the forward

### CUT GROOVE FOR LAUNCH LUG

SAND TO SHAPE



FIG. 6B

launch lug. Cut out the docking antenna pattern. Trace onto the BT-540 fin stock and cut out. Sand to shape and glue to the bottom of the Shuttlecraft bay.

Cut two 4" lengths of WD-2 wood dowel. Sand one end of each dowel as indicated. Position them on each side of the rear launch lug at the launch lug-body tube joint (General View). Glue the dowels into place.

Trace the fin fairing pattern onto the BT-540 fin stock to make the Reactor Radiator. Cut out, sand and glue to the rear launch lug.

### 9 RECOVERY SYSTEM

Cut the shock cord anchor from the plan sheet. Assemble as shown in "Recovery System-Parts" in your Estes catalog. Be sure that the shock cord anchor is set back at least 1" inside the body tube. Assemble the parachute as instructed in the parachute kit. See also "Rigging a Parachute" in your catalog.

### 10 PAINTING THE EXCALIBUR

RECOMMENDED COLORS  
WHITE-OVERALL ROCKET  
BLACK-COCKPIT AND DETAILING  
ORANGE-TRIM LINES  
OPTIONAL COCKPIT  
DETAIL PATTERN



### 11 COUNTDOWN CHECKLIST

Use your Rocket Flight Data Sheet (Parachute or Streamer section) to preflight, countdown and launch your Excalibur. When preparing the Excalibur for flight be sure to wrap enough masking tape around the forward and rear ends of the engine to make a snug fit. This will prevent ejection gas leakage and insure positive chute deployment.

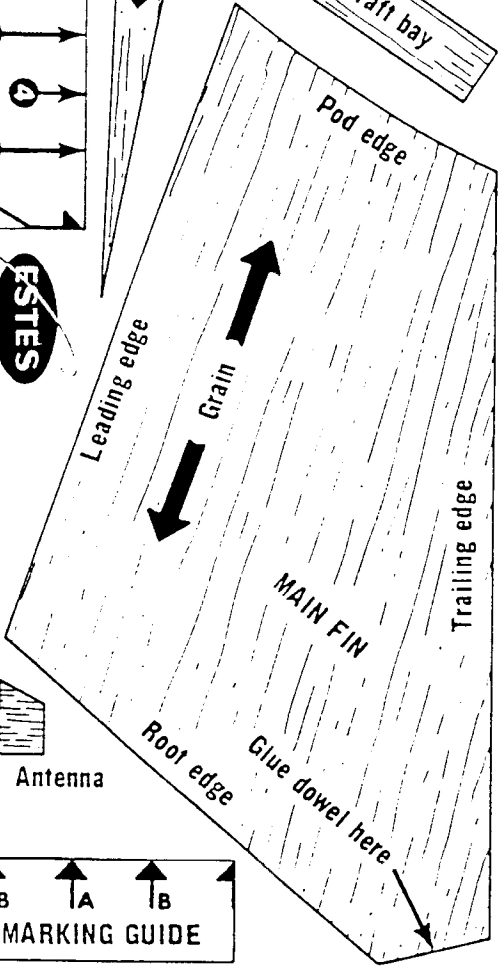
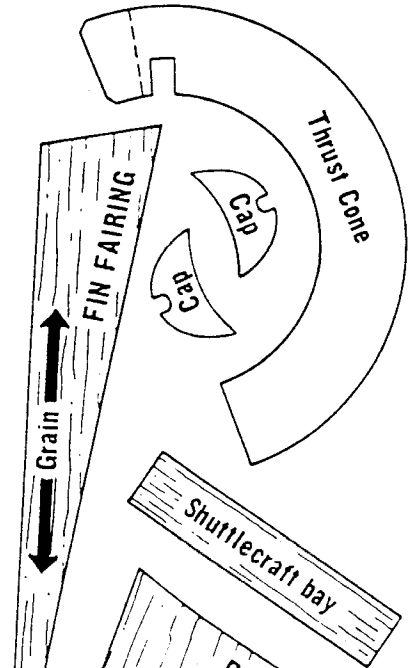
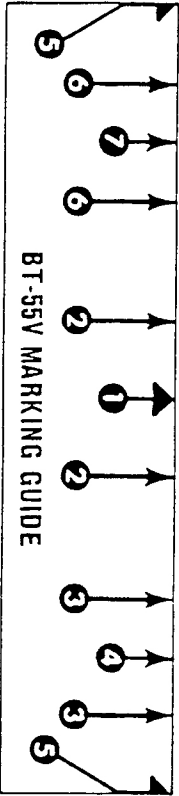

**ESTES**

STARSHIP EXCALIBUR

Rocket Plan No. 55 Pattern Sheet

Antenna

