

# Estes Industries Rocket Plan No.64

# PATNA MARK-I

MARCH 1969



DESIGN OF THE MONTH

by John Calvert Springfield, Ill.

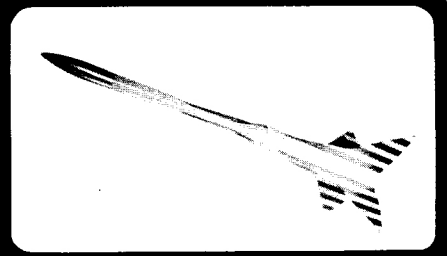

PUBLISHED AS A SERVICE TO ITS CUSTOMERS BY ESTES INDUSTRIES, INC., BOX 227, PENROSE, CO. 81240 © ESTES INDUSTRIES, INC., 1969

## PARTS LIST

- 1 Nose cone -- BNC-50Y
- 1 Body tube -- BT-60D
- 1 Body tube -- BT-50S
- 1 Body tube -- BT-20G
- 1 Body tube -- BT-20J
- 1 Tube adapter -- TA-2060
- 1 Tube adapter -- TA-2050
- 1 Engine mount Kit -- EH-2060
- 3 Sheet balsa fin stock -- BFS-30
- 1 Shock cord -- SC-1
- 2 Parachute Kit -- PK-12
- 1 Launch lug -- LL-2A
- 1 Screw eye -- SE-2

In addition to the parts above, you will need scissors, white glue, a sharp model knife (or razorblade), masking tape and paint or dope.

Assemble the engine mount according to the instructions **COUPLER** that came with the kit.

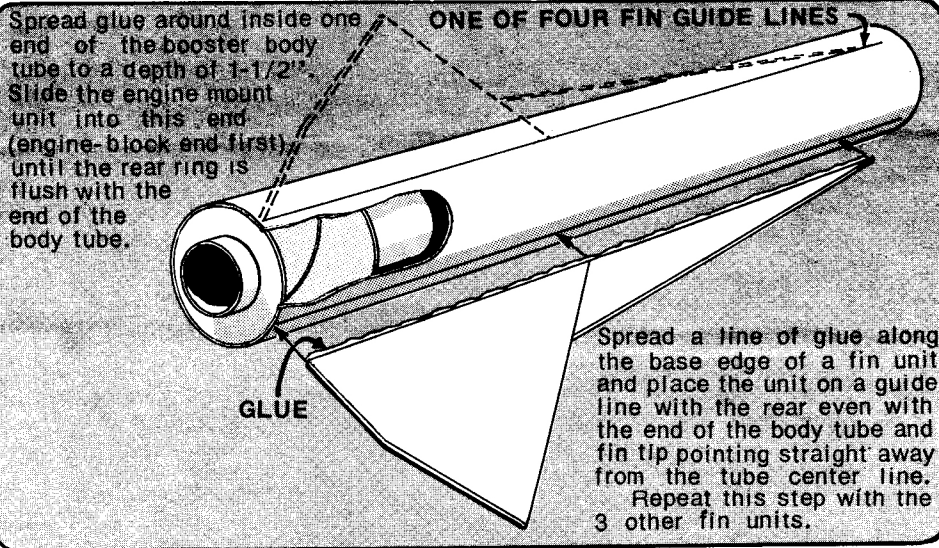
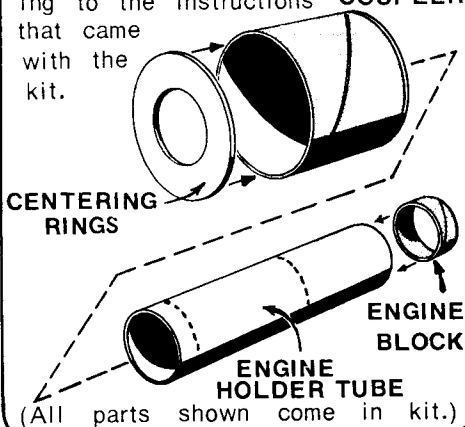

See the technical section of your catalog for installing the screw eye. Glue the BT-20G tube to the TA-2060 as shown.

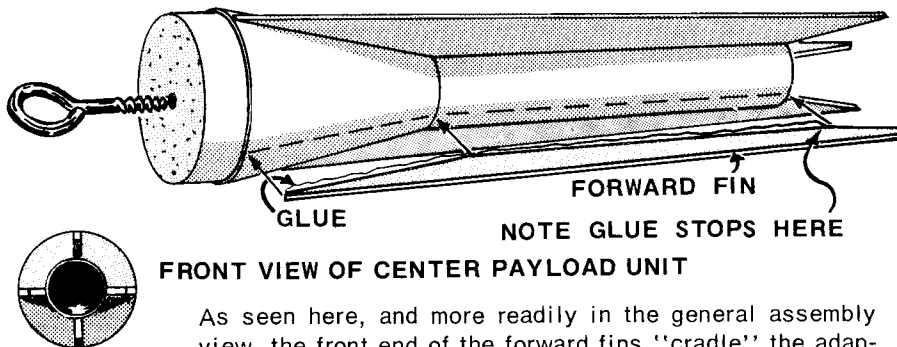

As seen here, and more readily in the general assembly view, the front end of the forward fins "cradle" the adapter base of the top payload section. Note the top payload base should fit snugly into the upper end of the center payload unit. The large end of the TA-2050 is glued into one end of the BT-50S to become the upper payload unit.

Trace and cut out main fin pattern, fin fairing and forward fairing patterns. Lay out four of each pattern on the balsa fin stock, starting with the main fins. Cut out all pieces and sand the sides smooth.

Pre-assemble the main fin and fin fairing pieces as shown.

### RULER TAPED TO FLAT SURFACE

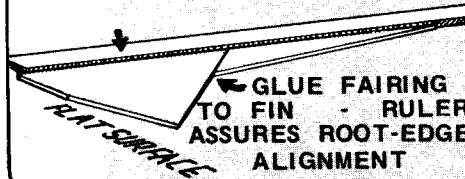

### MISC. CONSTRUCTION NOTES

General construction is "standard" . . . most of the steps are covered in the technical section of Estes' current catalog. Following are a few "specifics" for this bird.

1. Double recovery:- Tie only one 'chute to the shock cord and one 'chute to the screw eye of the center payload unit.
2. Launching lugs:- Cut the LL-2A in half and locate the pieces as shown in the view of the general assembly.
3. Painting:- Any bright or florescent color is worthwhile (this bird is a flyer) however, paint the payload units separately to get a neat job on the forward fins and upper payload adapter.

# GENERAL ASSEMBLY VIEW

# PATTERNS

