



Estes Industries Rocket Plan No. 65

SKY HIGH 3 Stage Rocket

APRIL '69

DESIGN OF THE MONTH WINNER

by Dale Olesberg Coeur D'Alene, Idaho

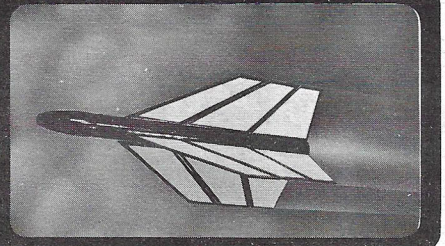

PUBLISHED AS A SERVICE TO ITS CUSTOMERS BY ESTES INDUSTRIES, INC., BOX 227, PENROSE, CO. 81240

© ESTES INDUSTRIES, INC. 1969

PARTS LIST

- | | |
|-------------------|---------|
| 3 Body Tube | BT-20-J |
| 1 Balsa Nose Cone | BNC-20B |
| 3 Balsa Fin Stock | BFS-20L |
| 1 Launching Lug | LL-2B |

In addition to the parts listed above, you will also need white glue, masking tape, scissors, a model knife or razor blade, sandpaper, carbon paper, a piece of heavy paper, a brush and paint or dope.

Mark the three body tubes for 4 fins each

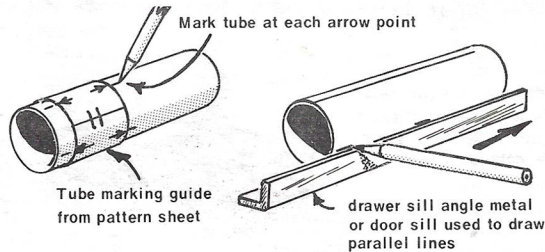

Glue the nose cone into one of the body tubes.

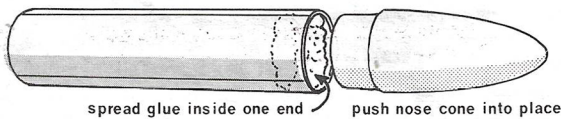

Glue the fins to the body tube for each stage.

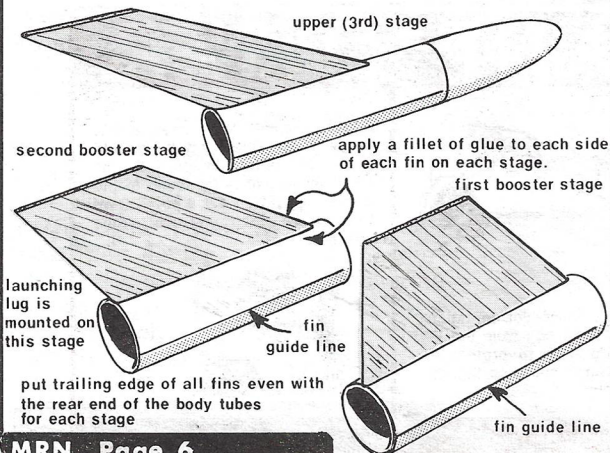

FULL SIZE FIN PATTERNS

Do part of the work necessary for a good paint job before gluing the fins on the model. When all fins have been cut from the sheet balsa stock, sand the leading, tip and trailing edges round. Sand the edges that glue to the body tube flat.

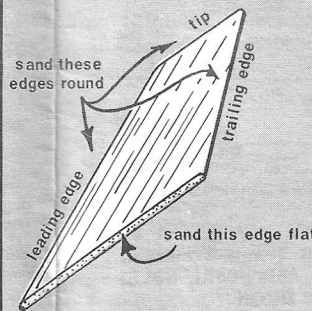

Sand the sides of each fin smooth to the touch with extra-fine sandpaper.

Trace these patterns onto heavy paper and cut them out. Lay out four parts from each pattern, matching the grain direction of the balsa with that shown on each pattern.

For additional details refer to the technical section of your current Estes catalog.

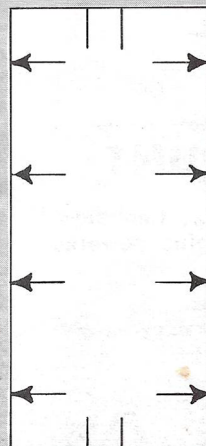
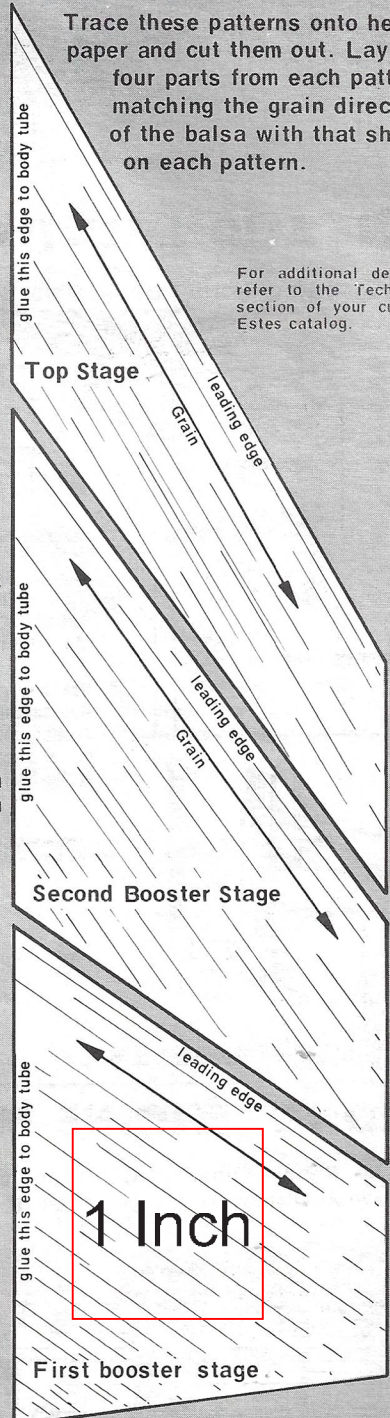

Fin Marking Guide

Trace guide onto typing paper; cut out and wrap around each body tube. Mark the tube at each arrow point, then extend a line through each pair of marks for the length of the tube. Repeat for other two tubes.

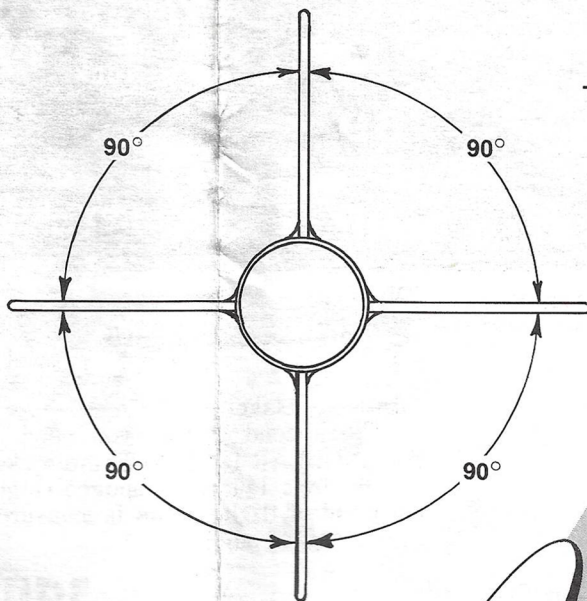
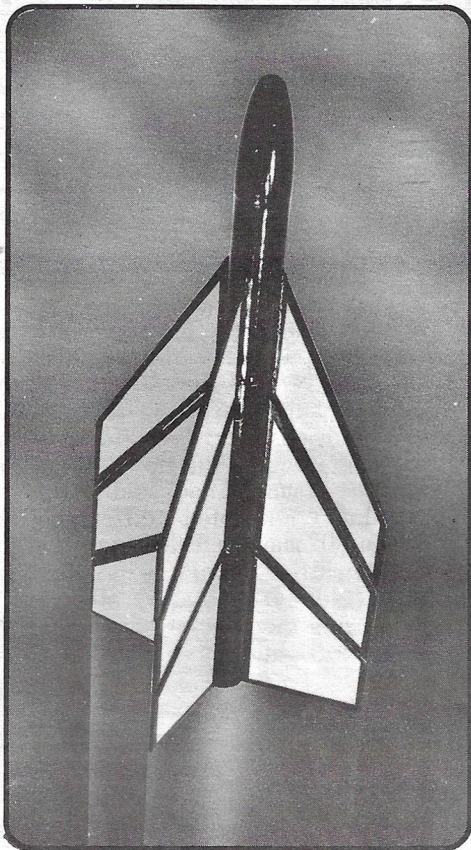

REAR VIEW
Typical of all three stages

For additional details, refer to the Technical section of your current Estes catalog.

PAINTING



Since "out-of-sight" flights are easily possible with this rocket, we suggest that you paint your bird with extra high visibility fluorescent paints or at least with colors which are not otherwise found in your flying area.

FLYING

Since the boosters use tumble recovery and the upper stage has feather-weight recovery, special attention need be paid only to preparation of the engines for stage ignition and for fit in their respective stages.

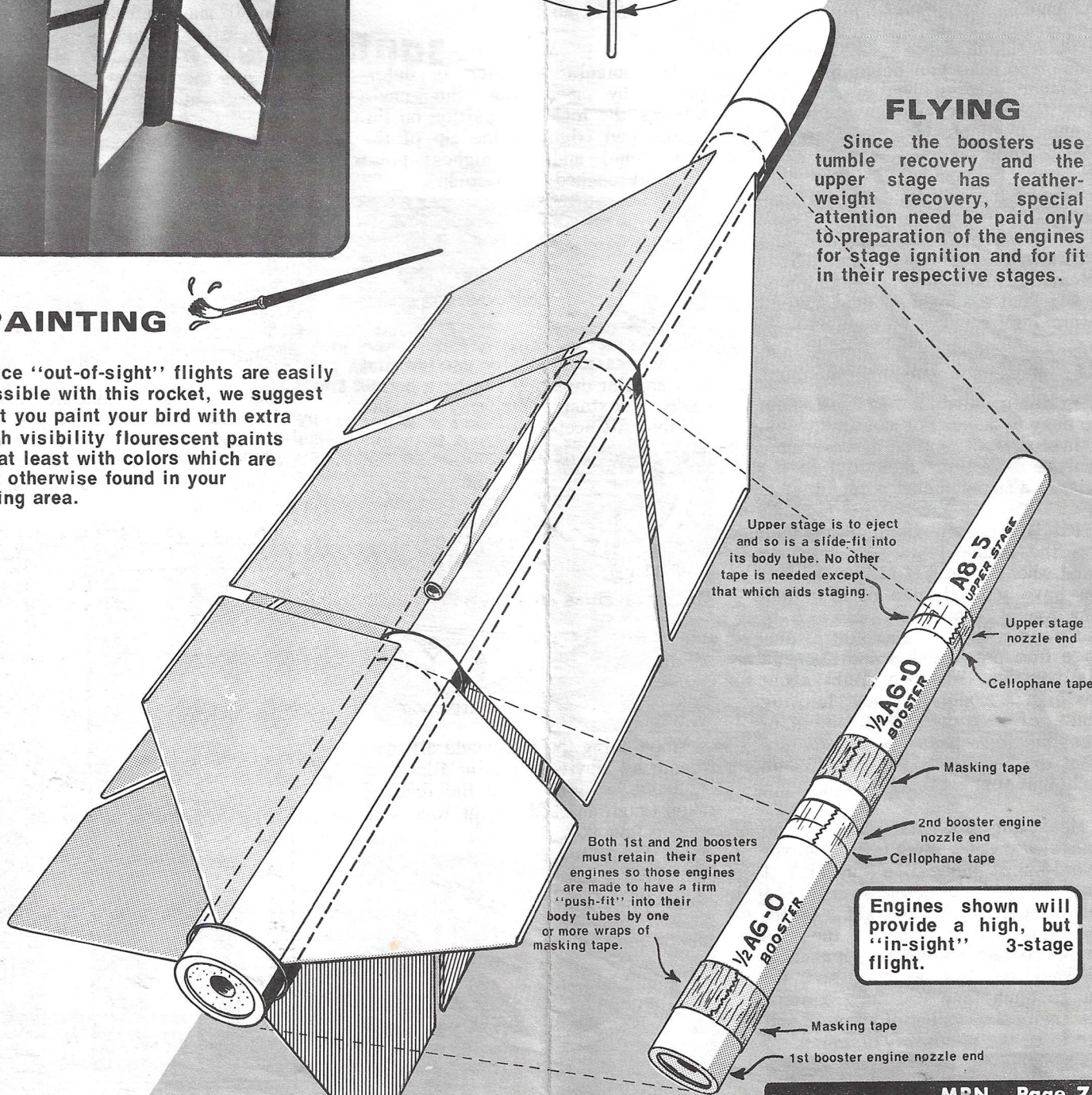

Upper stage is to eject and so is a slide-fit into its body tube. No other tape is needed except that which aids staging.

Both 1st and 2nd boosters must retain their spent engines so those engines are made to have a firm "push-fit" into their body tubes by one or more wraps of masking tape.

Engines shown will provide a high, but "in-sight" 3-stage flight.