

Estes Industries Rocket Plan No. 71
BLACK KNIGHT
 JAN. '70

DESIGN OF THE MONTH WINNER
 by Joseph Aitken, APO San Francisco, Calif.

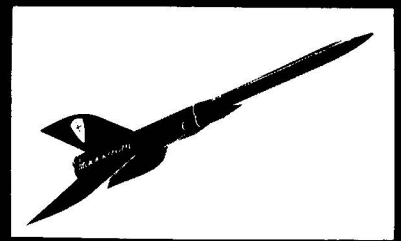

PUBLISHED AS A SERVICE TO ITS CUSTOMERS BY ESTES INDUSTRIES, INC., BOX 227, PENROSE, CO. 81240

© ESTES INDUSTRIES 1970

PARTS LIST

- | | | |
|---|-------------------|----------|
| 1 | Body Tube | BT-50W |
| 2 | Body Tubes | BT-50H |
| 1 | Body Tube | BT-20D |
| 1 | Body Tube | BT-20J |
| 1 | Body Tube | BT-5P |
| 1 | Nose Cone | BNC-20N |
| 2 | Nose Cones | BNC-5S |
| 1 | Tube Adapter | TA-2050A |
| 2 | Tube Adapters | TA-550 |
| 2 | Nose Blocks | NB-50 |
| 3 | Fin Stock | BFS-20 |
| 1 | Engine Holder | EH-2 |
| 5 | Centering Rings | RA-2050 |
| 2 | Parachute Kits | PK-8 |
| 2 | Screw Eyes | SE-3 |
| 2 | Shock Cords | SC-1 |
| 2 | Snap Swivels | SV-12 |
| 1 | Launching Lug | LL-2B |
| 3 | Nose Cone Weights | NCW-2 |
| 1 | Fin Pattern Sheet | FP-1-71 |
- (Fin pattern will be sent free with order if requested, or send a stamped self-addressed envelope.)

You will also need a model knife, glue sandpaper, a brush and paint.

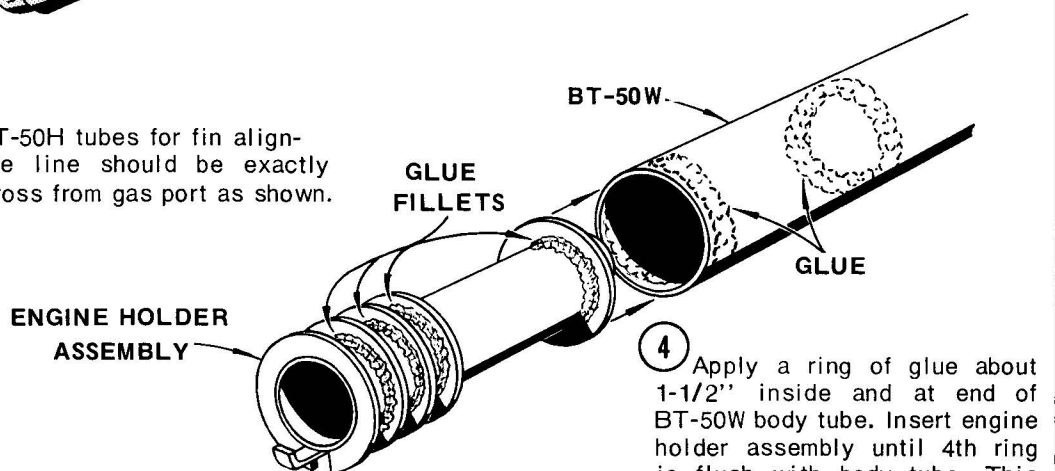
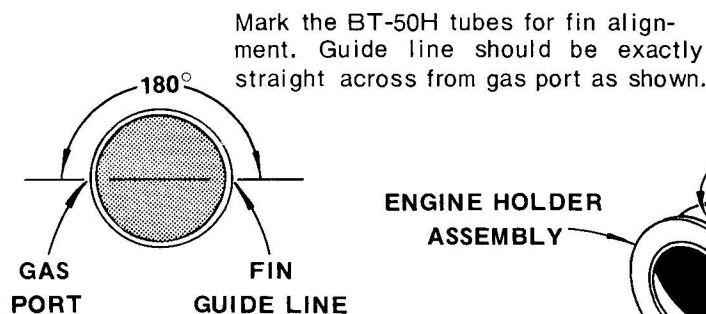
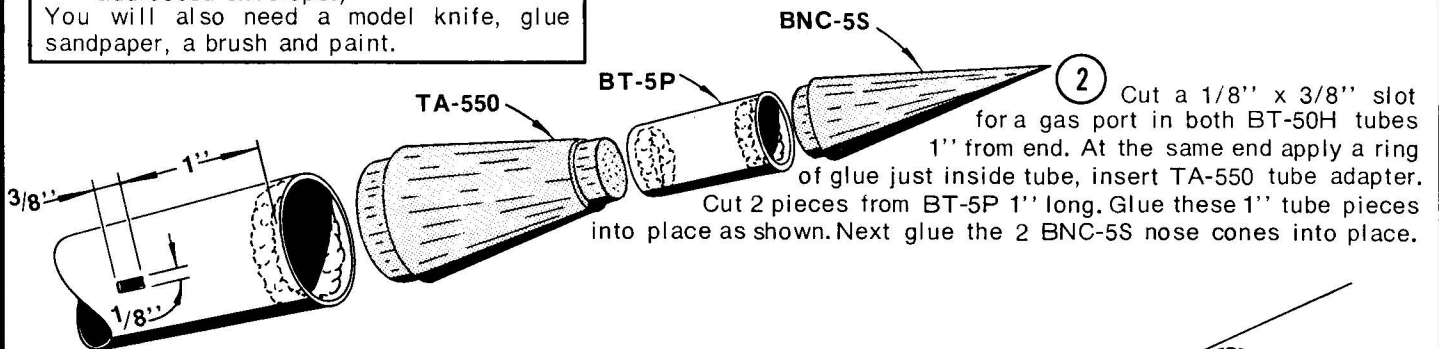
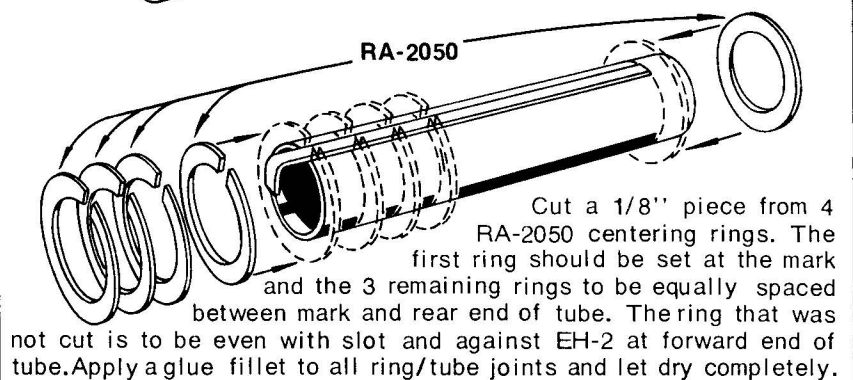
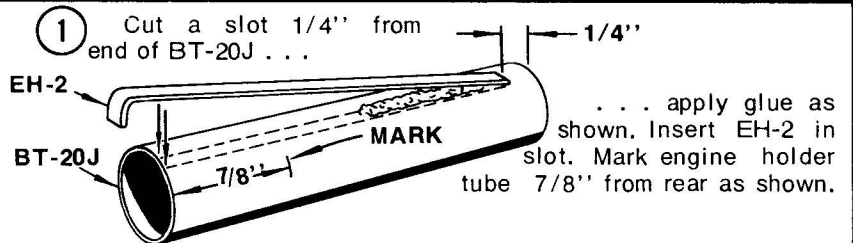

3 Copy fin pattern from pattern sheet onto BFS-20 observing grain direction. Cut fins out and sand all leading and trailing edges round,

4 Apply a ring of glue about 1-1/2" inside and at end of BT-50W body tube. Insert engine holder assembly until 4th ring is flush with body tube. This should be done in one smooth motion or the assembly may freeze in the wrong position.

5 Mark the BT-50W body tube at 120° for 1/8" x 3/8" gas ports and rudder. Gas ports to be 2-11/16" from front of tube.

Use the marking guide in the Technical Section of your ESTES catalog.

6 Glue tube adapter TA-2050 and body tube BT-20D into place as shown. Do not glue nose cone BNC-20N if payload is desired.

7 Attach both BT-50H tubes to the BT-50W body tube. Be sure gas ports are lined up exactly. Apply a good glue fillet to both tube joints.

8 Attach fins as shown. Launch lug should be centered on bottom of BT-50W and antennas should be centered, one on each side of BT-50W as shown.

9 Attach recovery system and shock cords to the nose blocks as shown. Use standard shock cord anchor.

Suggested color for the Black Knight is black with white trim.

RECOMMENDED ENGINES	SPECIFICATIONS
A8-3 - B6-4 - C6-5	Length ----- 24"
A8-3 for first flight.	Fin Span ----- 6.5"
	Weight ----- 2.5 oz.

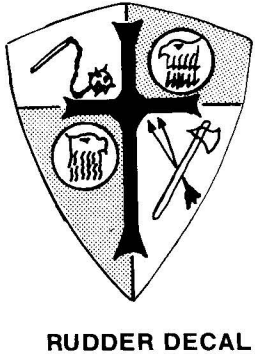
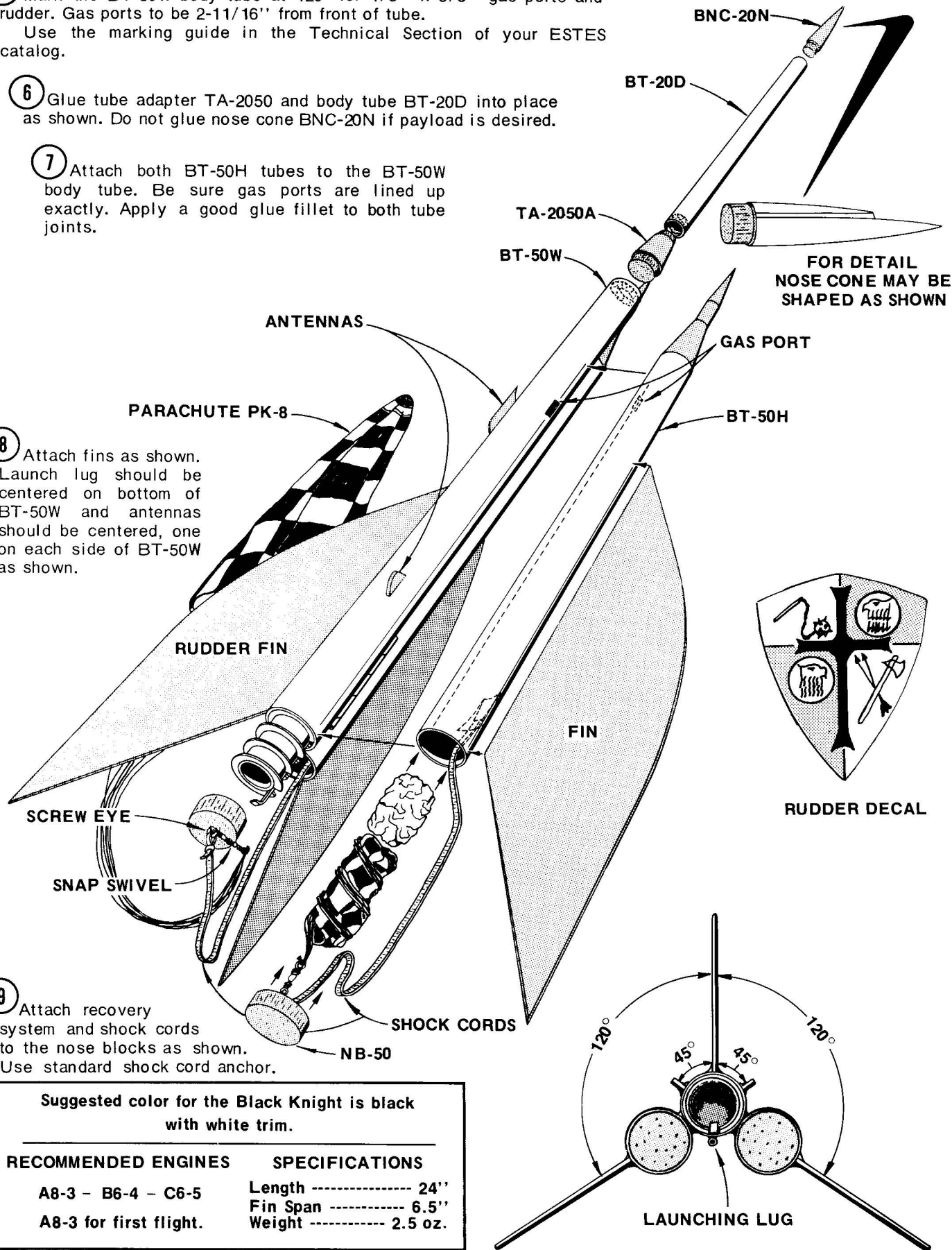

RUDDER DECAL



A SUBSIDIARY OF DAMON
ESTES INDUSTRIES
BOX 227, PENROSE, COLO. 81240

FP-1-71

BLACK KNIGHT fin pattern sheet

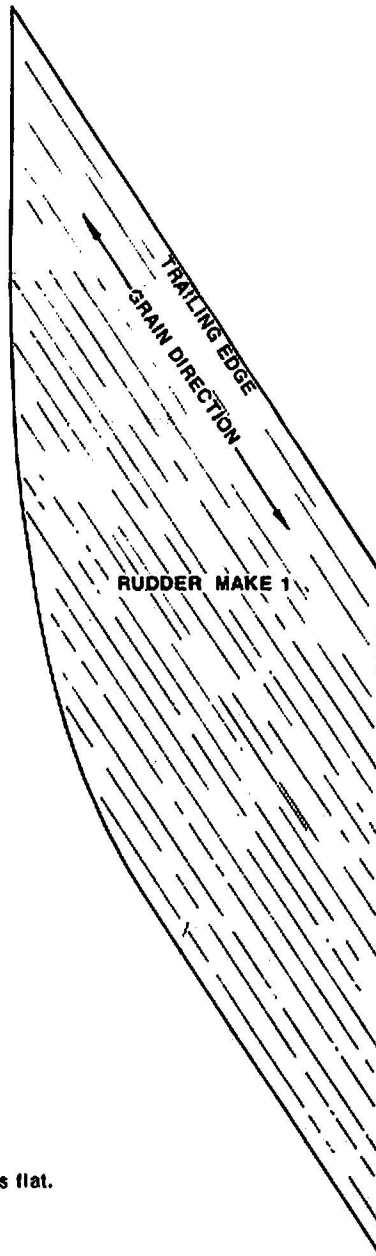
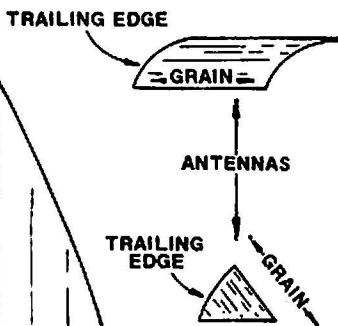
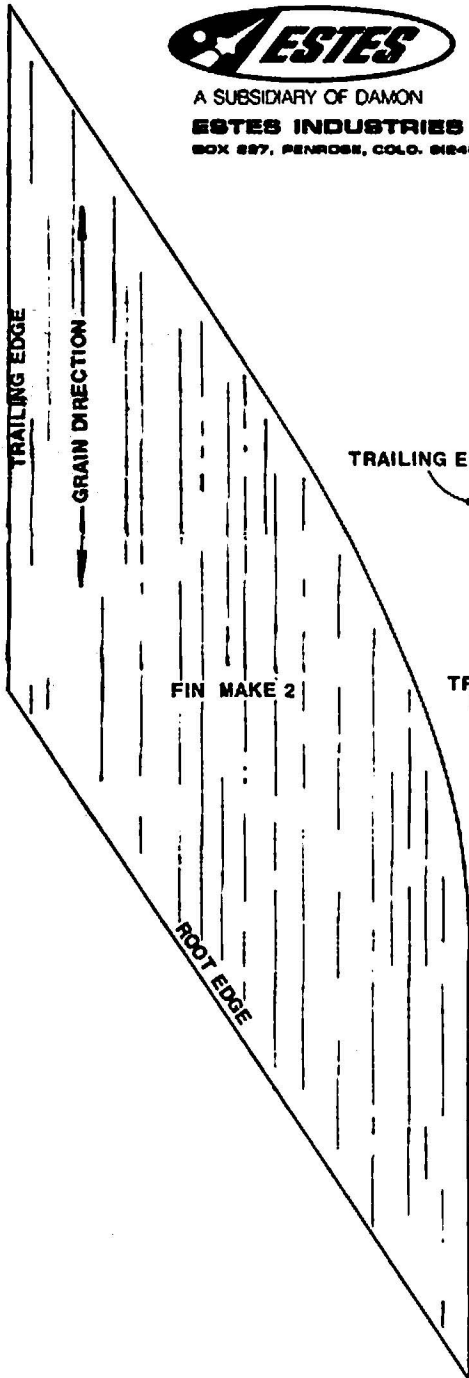

Sand all leading and trailing edges round and all root edges flat.