



EstesRockets.com

ESAM-58™

0661



MODEL ROCKET INSTRUCTIONS

KEEP FOR FUTURE REFERENCE

IMPORTANT: Please record date found on decal and keep for future reference. _____

Read all instructions. Make sure you have all parts and supplies. Test fit all parts before applying glue. Product color and shape may vary.

SUPPLIES



SCISSORS



PENCIL



RULER



FINE SANDPAPER



YELLOW GLUE



HOBBY KNIFE



MASKING TAPE



PRIMER (WHITE)



PAINT (RED, GRAY)



CLEAR COAT (OPTIONAL)



PLASTIC CEMENT



CLEAR TAPE

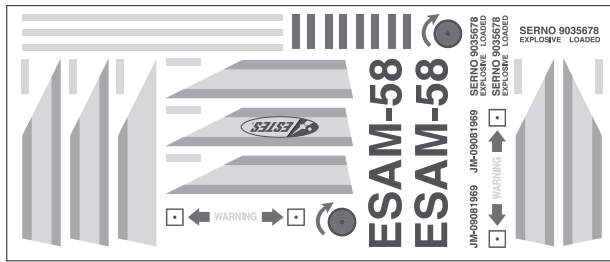

090001-0661
Decal sheet

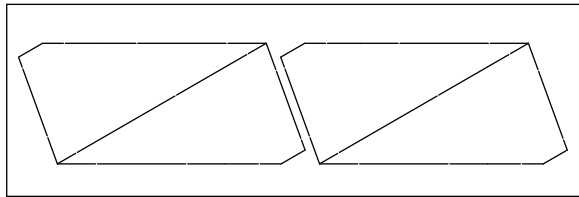

F 090051-0661A
Laser cut wood sheet

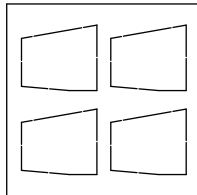

E 090051-0661B
Laser cut wood sheet

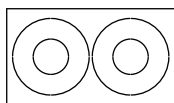

C 090052-0661
Laser cut card stock



I 072421/422
Engine retainer set

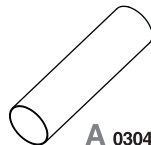

B 030162-2
Green engine block

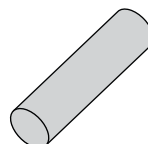

H 035003
Yellow spacer tool



G 038176
Launch lug

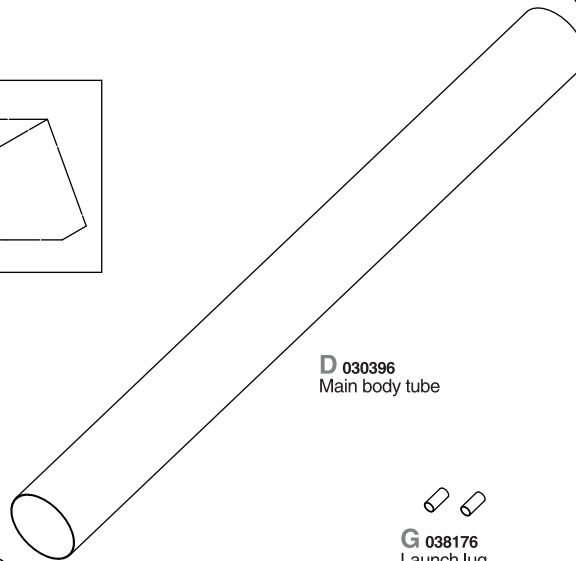

D 030396
Main body tube



L 038363
Shock cord

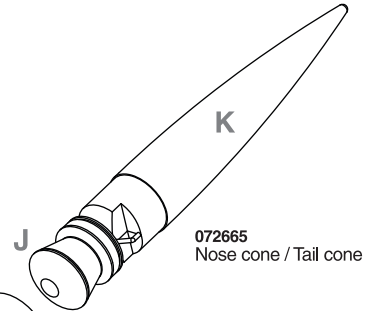

072665
Nose cone / Tail cone

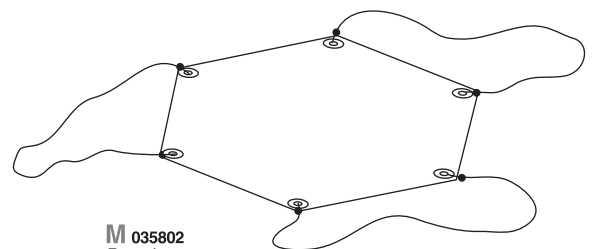

M 035802
Parachute

TUBE MARKING GUIDE & SHOCK CORD MOUNT

Make a copy if you want to keep instructions.

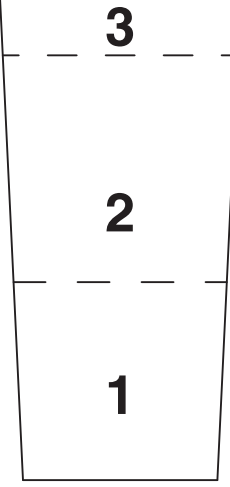
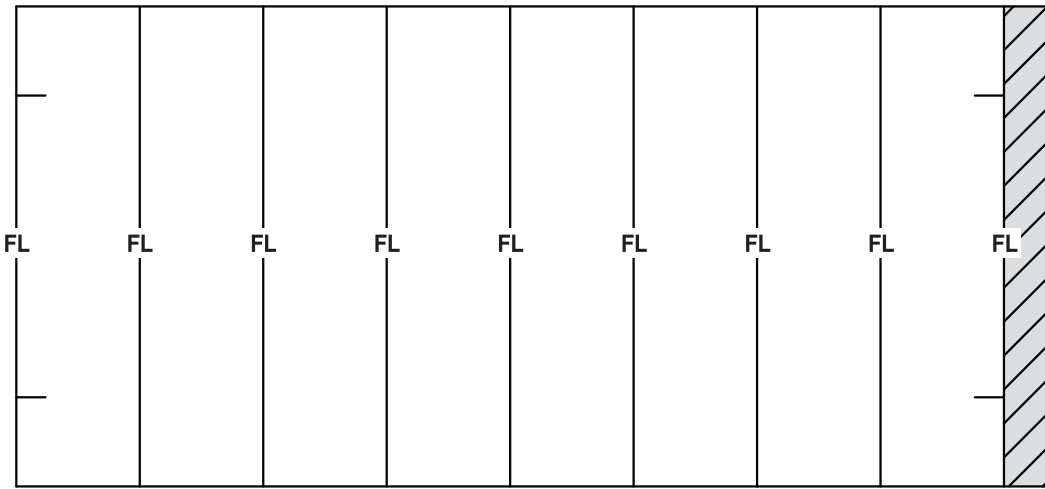

PREPARE NOSE CONE

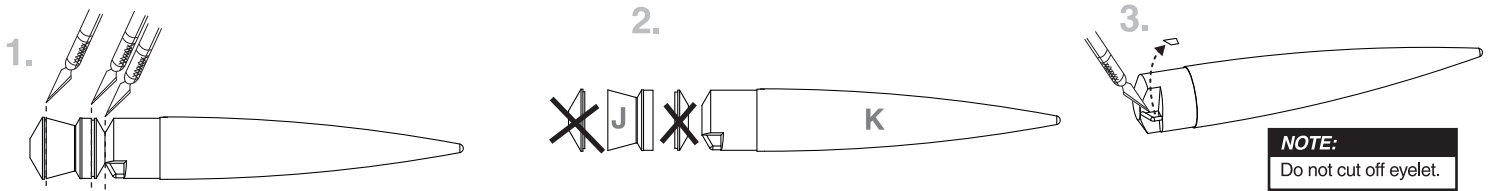

ASSEMBLE ENGINE MOUNT

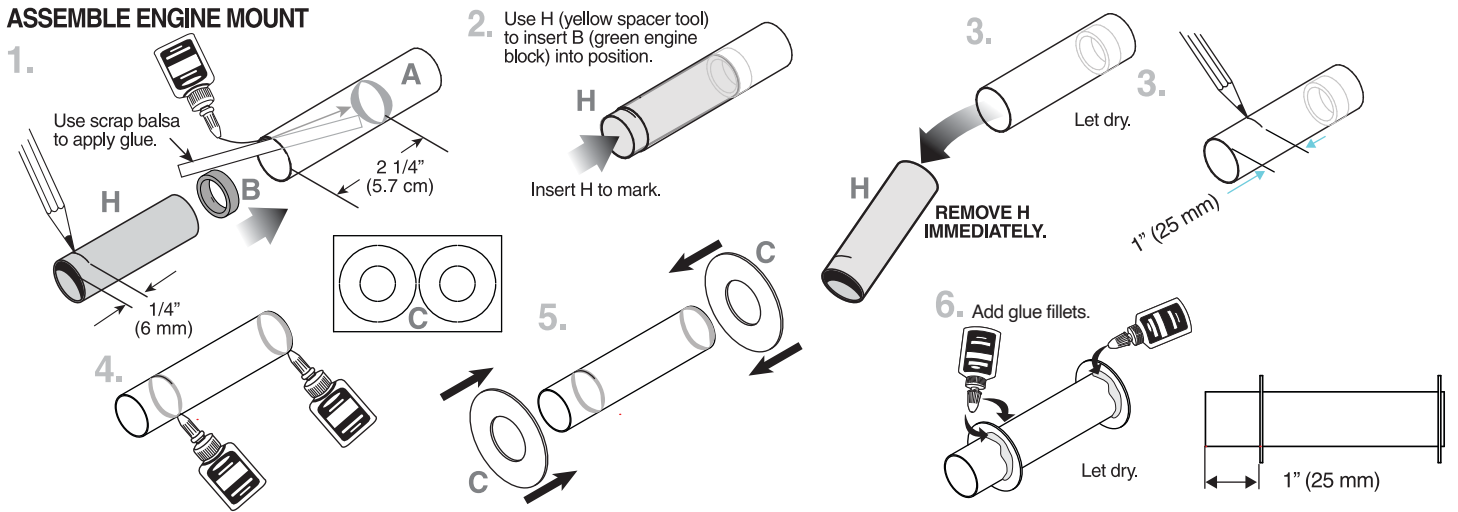

MARK TUBE

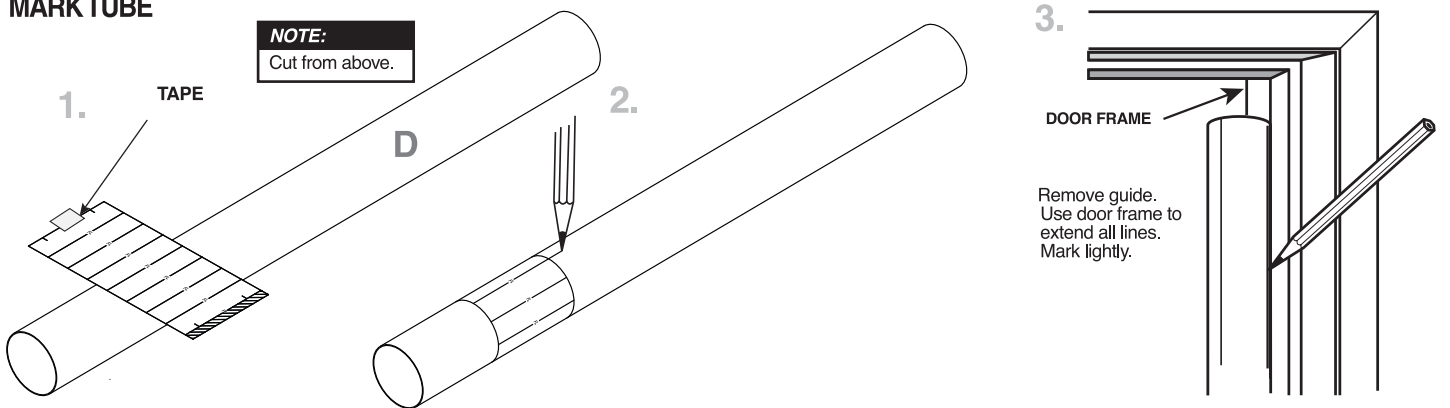

INSTALL ENGINE MOUNT

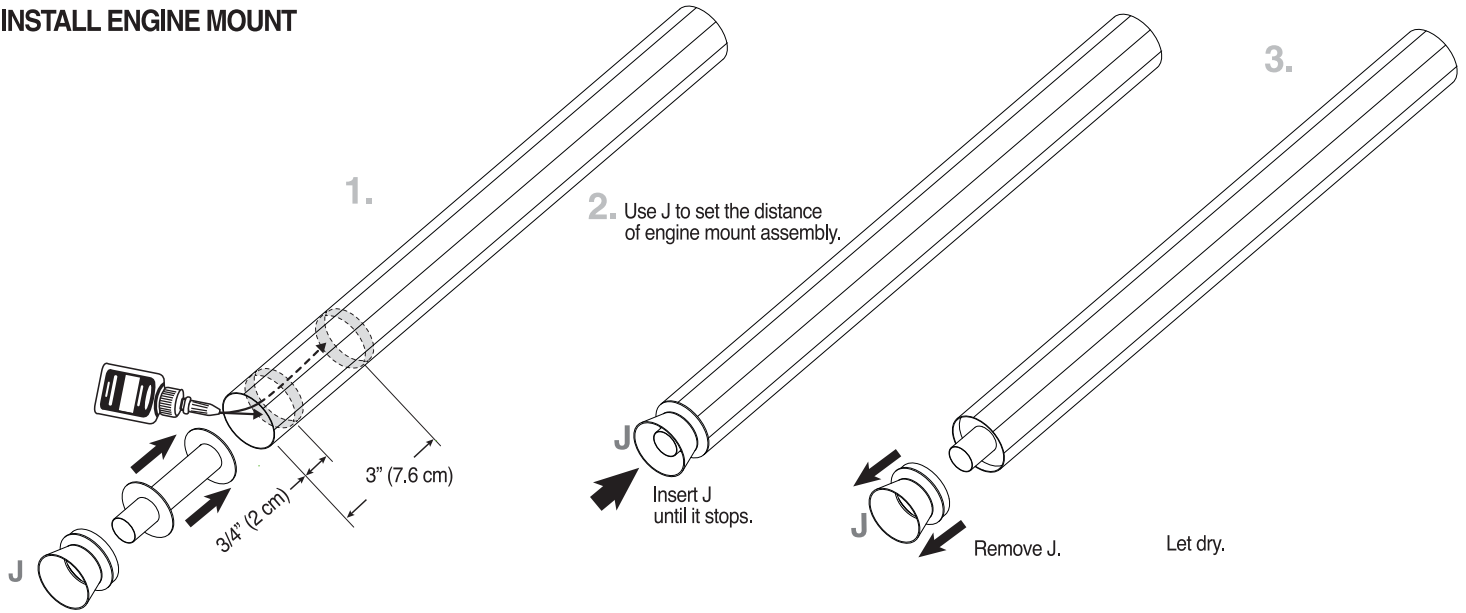

ATTACH FINS

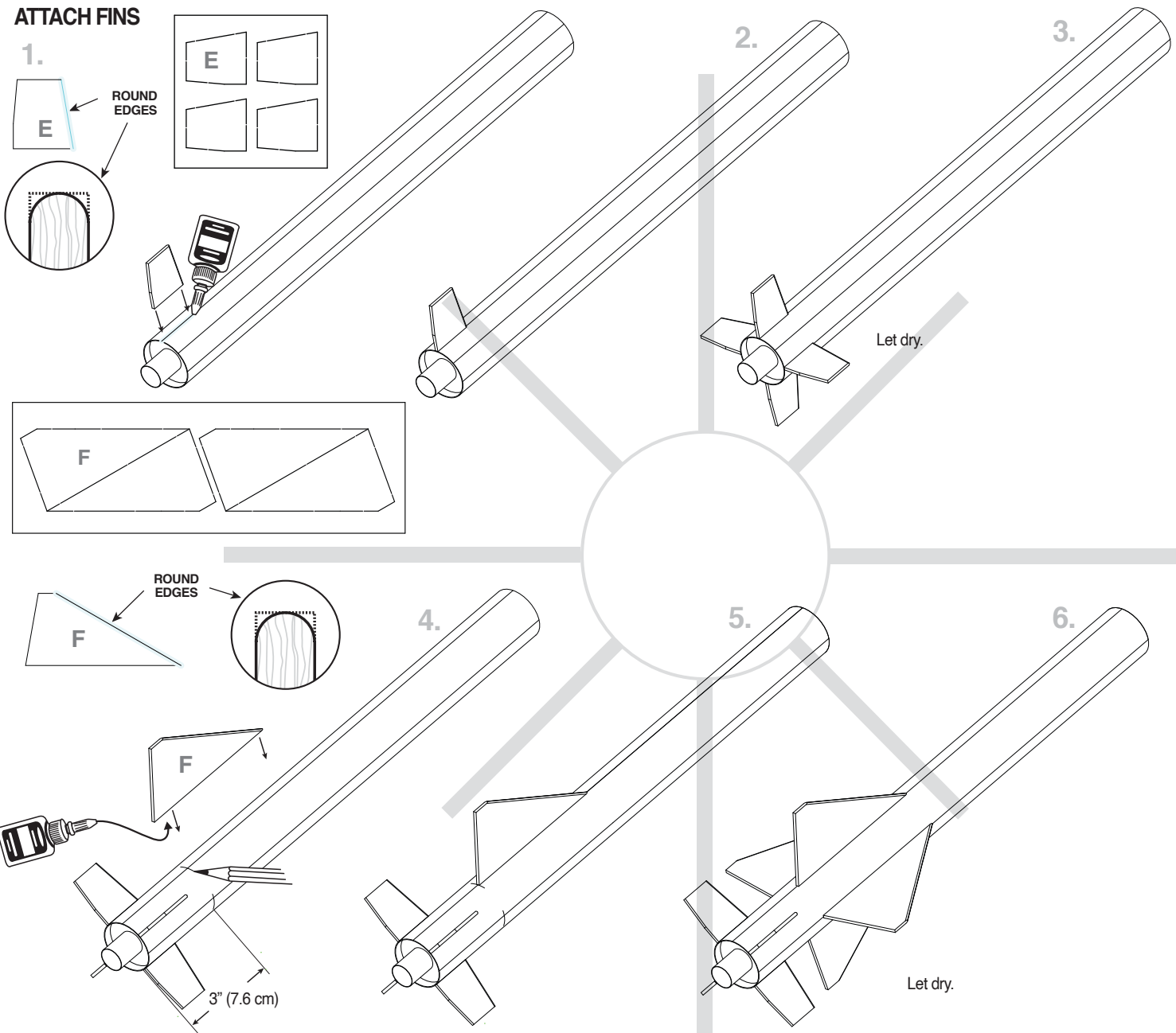

ATTACH LAUNCH LUGS

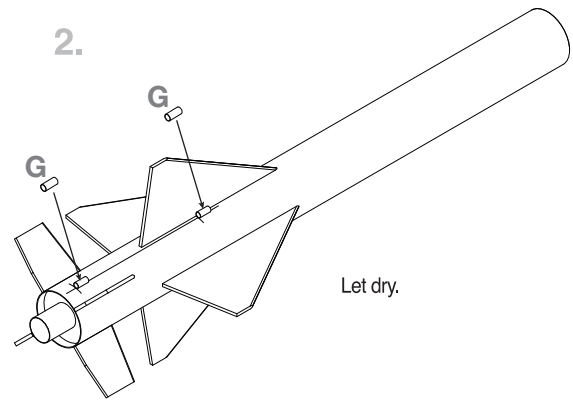
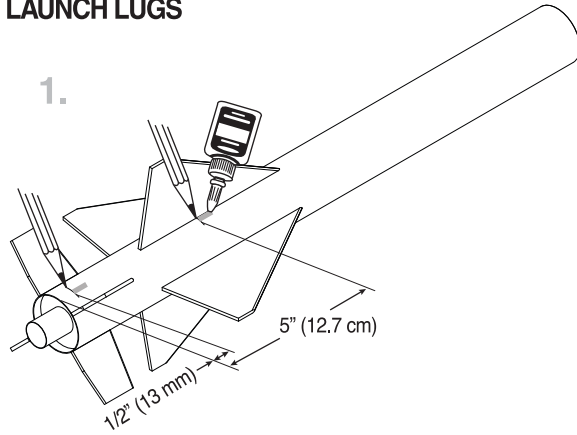

ATTACH TAIL CONE AND ENGINE RETAINER

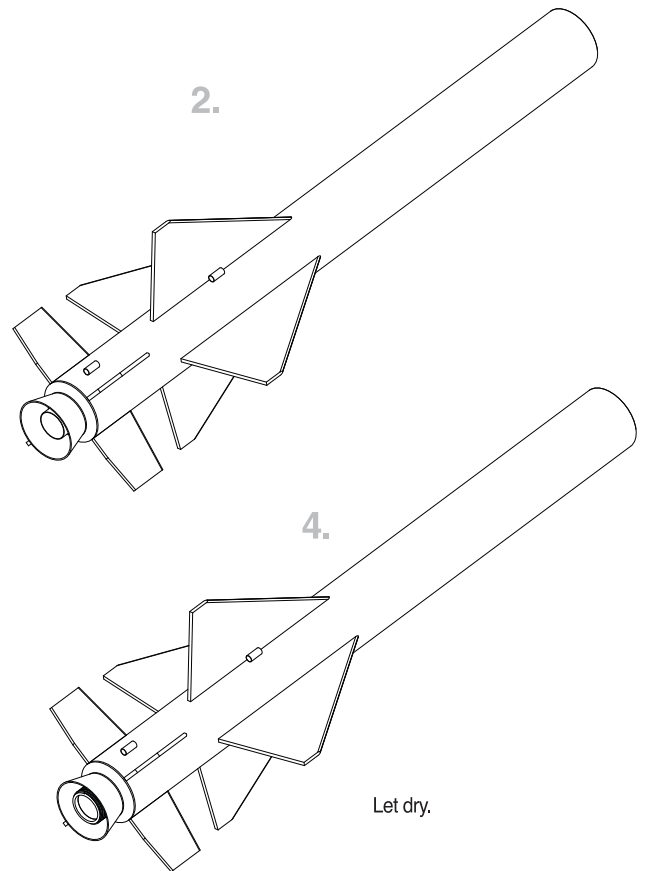
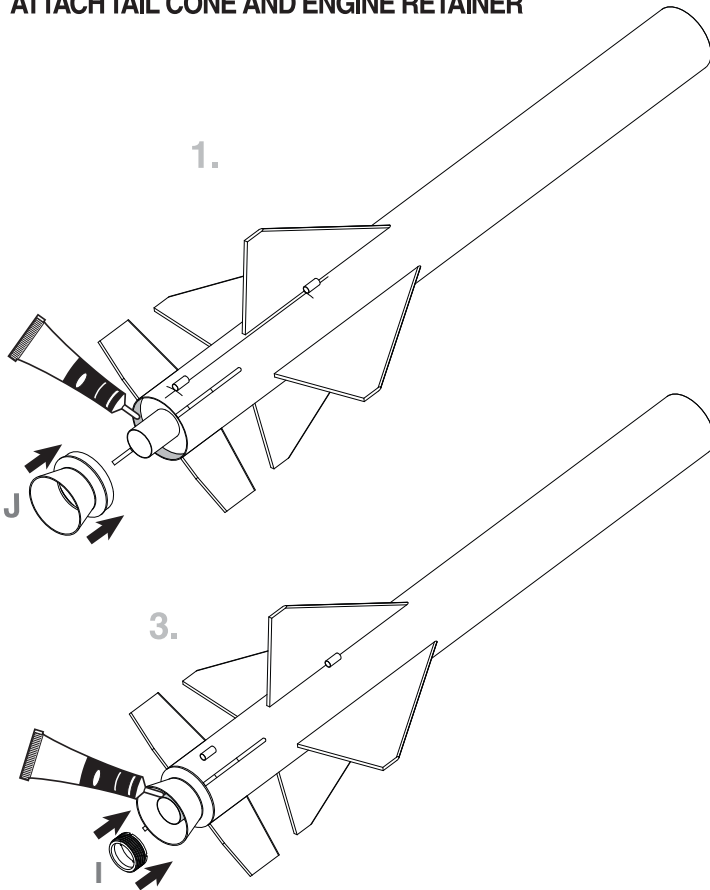

ROCKET FINISHING

1. Spray rocket with white primer, let dry, and sand. Repeat until rocket is smooth, then paint. Apply decals after paint is dry.
2. Cut decals from sheet, trimming close to edge.
3. One at a time, place in warm water until decal curls and begins to relax.
4. Remove and position on rocket, sliding decal away from backing material.
5. Blot with clean paper towel. Let set overnight.
6. OPTIONAL: Apply protective clear coat.



INSTALL SHOCK CORD

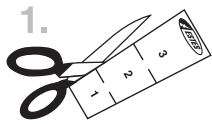

NOTE:
Cut from page 2.

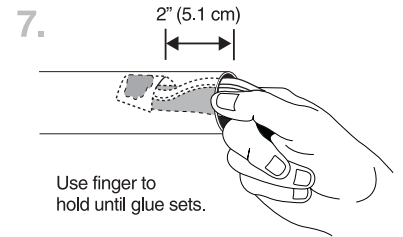
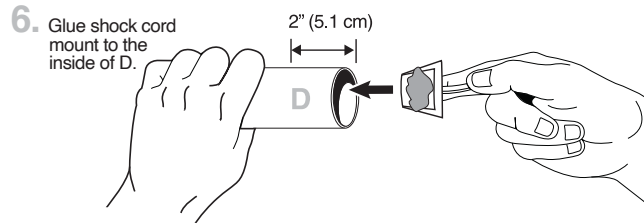
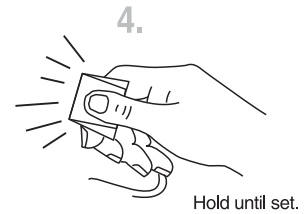
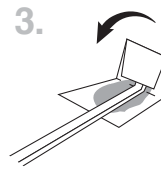
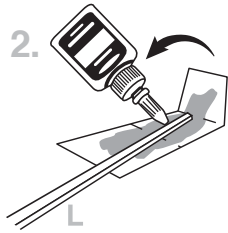

PREPARE RECOVERY SYSTEM

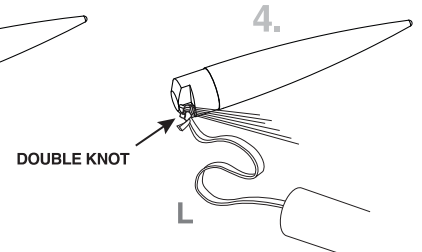
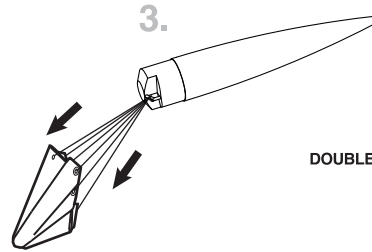
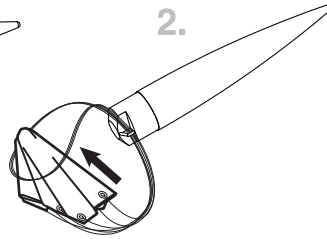
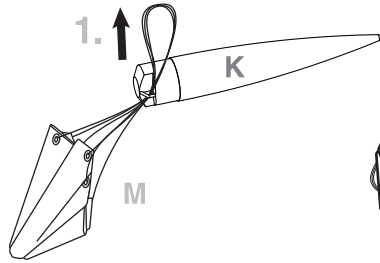

PREPARE FLIGHT RECOVERY

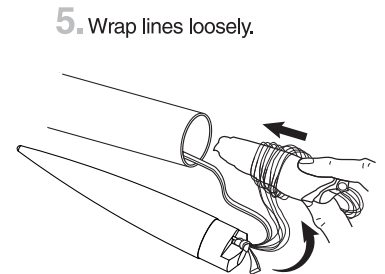
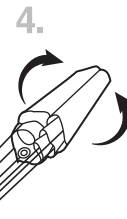
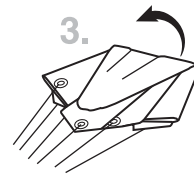
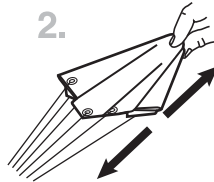
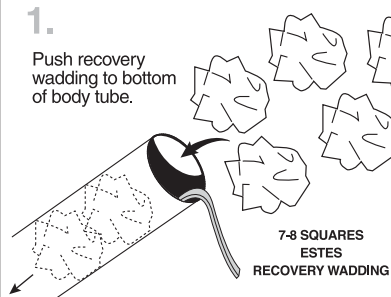

NOTE:
Recovery wadding and parachute must slide easily into body tube. If too tight, redo.

PREPARE ENGINE

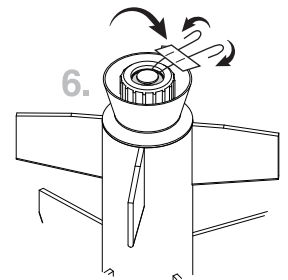
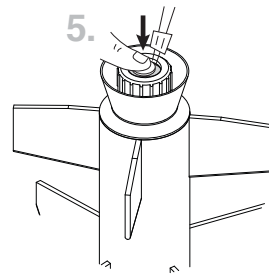
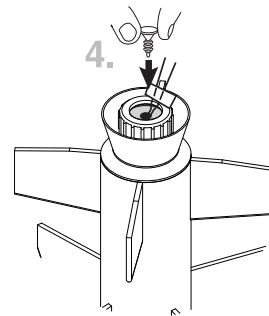
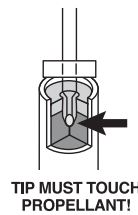
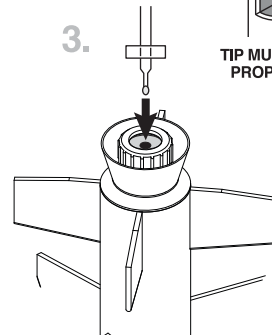
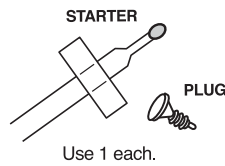
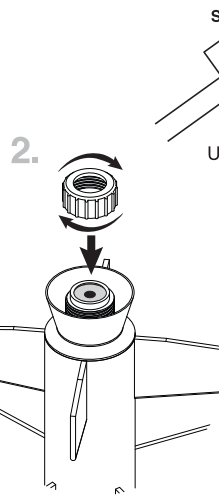
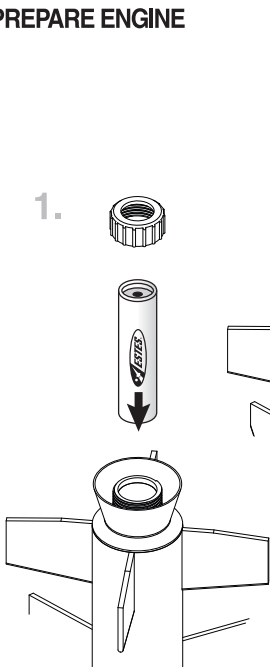

⚠ WARNING: FLAMMABLE
To avoid serious injury, read instructions & NAR Safety Code included with engines. **PREPARE YOUR ENGINE ONLY WHEN YOU ARE OUTSIDE AT THE LAUNCH SITE PREPARING TO LAUNCH.** If you do not use your prepared engine, remove the starter before storing your engine.

FLIGHT SEQUENCE

NOTE:
Key always out until final countdown!

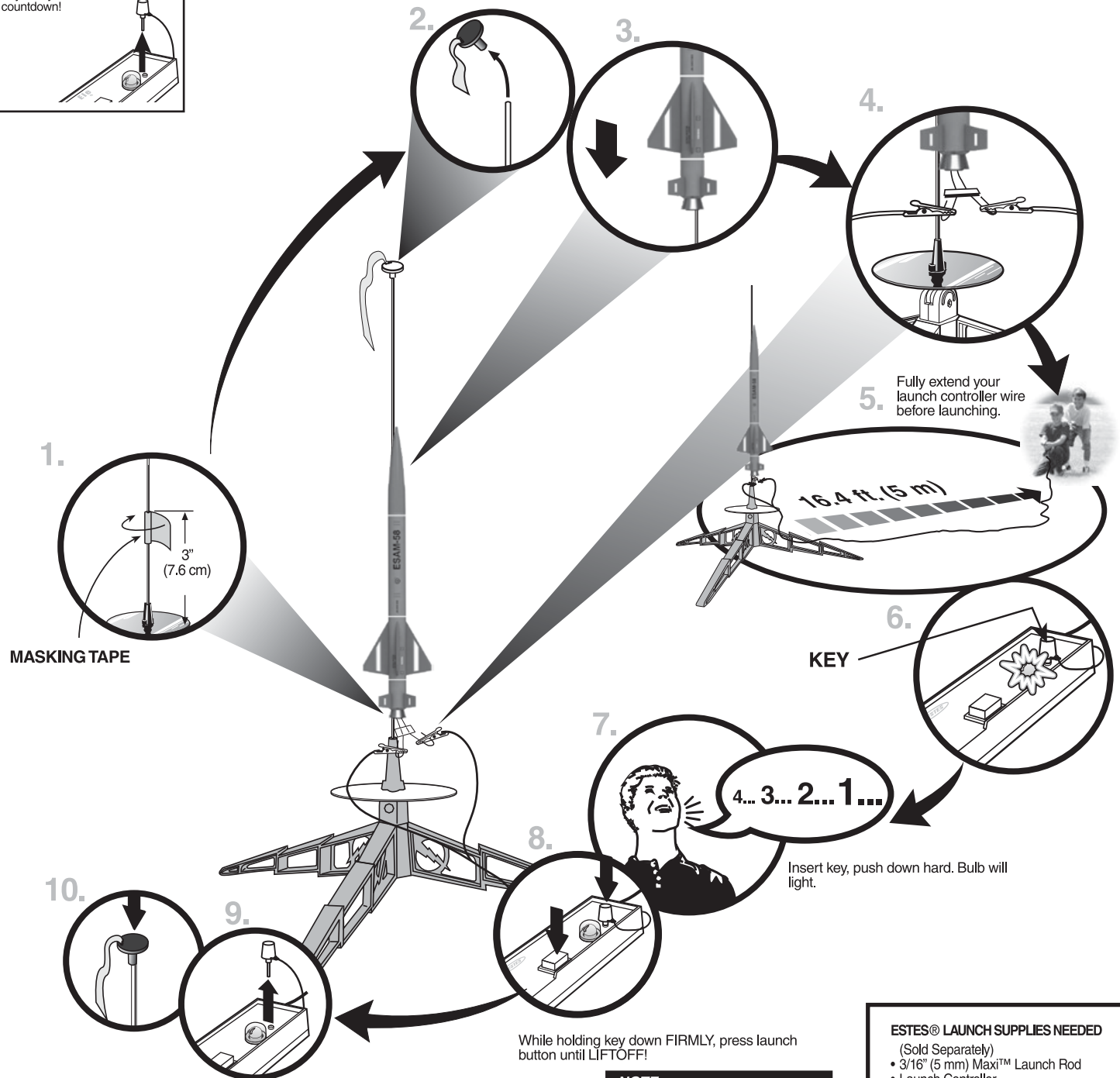

- ESTES® LAUNCH SUPPLIES NEEDED**
(Sold Separately)
- 3/16" (5 mm) Maxi™ Launch Rod
 - Launch Controller
 - Recovery Wadding
 - Starters (with engines)
 - Plugs (with engines)
 - Estes® Engines: B6-4 (first launch), C6-5

PRECAUTIONS



NAR SAFETY CODE



NO DRY GRASS OR WEEDS

PRE-LAUNCH CHECK For safety, never launch a damaged rocket. Check the rocket's body, nose cone and fins. Also, check the engine mount, recovery system and launch lug(s). Repair any damage before launching the rocket.

FLYING YOUR ROCKET Choose a large field (500 ft. [152 m] square) free of dry weeds and brown grass. The larger the launch area, the better your chance of recovering your rocket. Football fields and playgrounds are great. Launch only with little or no wind and good visibility. Always follow the National Association of Rocketry (NAR) SAFETY CODE (enclosed).

MISFIRES TAKE THE KEY OUT OF THE CONTROLLER. WAIT ONE MINUTE BEFORE GOING NEAR THE ROCKET! Disconnect the starter clips and remove the engine. Take the plug and starter out of the engine. If the starter has burned, it worked but did not ignite the engine because it was not touching the propellant inside the engine. Put a new starter all the way inside the engine without bending it. Push the plug in place. Repeat the steps under Countdown and Launch.

