



www.estesrockets.com

ESTES® INDUSTRIES
1295 H Street
Penrose, CO 81240
PRINTED IN USA

ORBITAL TRANSPORT™

FLYING MODEL ROCKET KIT INSTRUCTIONS

EST 1259

KEEP FOR FUTURE REFERENCE.

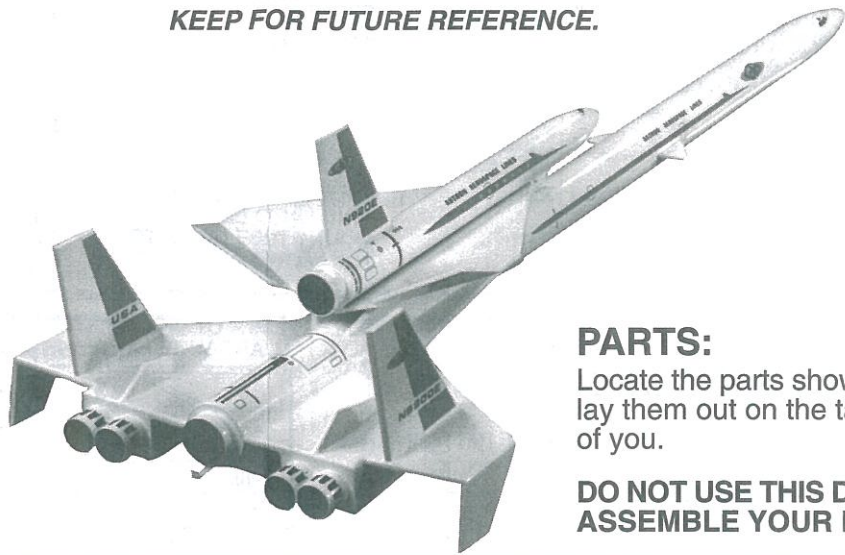

ASSEMBLY TIP

Read all instructions before beginning work on your model. Make sure you have all parts and supplies.

TEST-FIT ALL PARTS TOGETHER BEFORE APPLYING ANY GLUE.

If any parts don't fit properly, sand as required for precision assembly.

PARTS:

Locate the parts shown below and lay them out on the table in front of you.

DO NOT USE THIS DRAWING TO ASSEMBLE YOUR ROCKET.

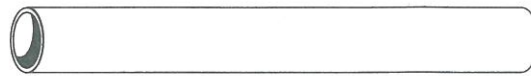
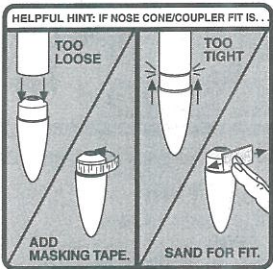

BOOSTER BODY TUBE BT-50 (1)
(30352)

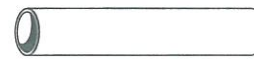

ORBITER BODY TUBE BT-20D (1)
(30317)



BLUE ENGINE MOUNT TUBE 20J (1)
30326-1



WHITE BODY TUBE BT-5 (4)
(31174)



GREEN ADAPTER RING AR 2050 (2)
(30164-2)



NOSE CONE INSERT PIN-50YR (1)
(072605)



NOSE CONE PNC-50YR (1)
(072604)

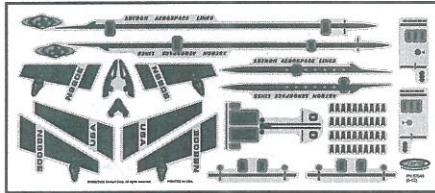

Decal Sheet (1)
(37040)



ENGINE HOOK (1)
(35021)



LAUNCH LUG LL2B (1)
38178

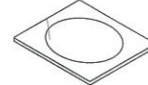

DIE CUT DISC NB-20 (1)
(32474)



NOSE CONE PNC-20 (1)
(72606)

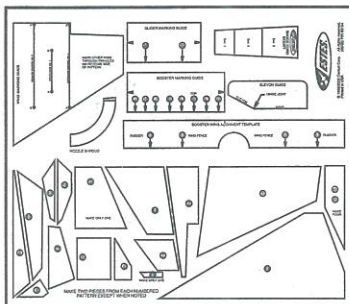

PATTERN SHEET (1)
(83154)

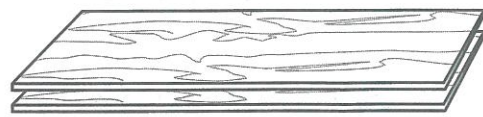

BALSA SHEET 3/32" X 3" X 12" (2)
(32110)

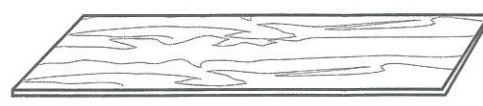

BALSA SHEET 1/16" X 3" X 12" (1)
(32106)



WOOD DOWEL 1/8 X 3/4" (1)
(32053)



SHOCK CORD 1/4" X 36" (1)
(38382)

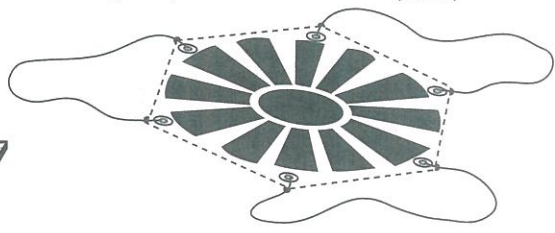

ASSEMBLED 18" PARACHUTE (1)
(35802)

ALL GLUED AREAS ARE SHADED IN GRAY

SUPPLIES

In addition to the parts included in the kit you will also need:



SCISSORS



PENCIL



RULER



FINE SAND PAPER (#400-600 GRIT)



CARPENTER'S GLUE



MODELING KNIFE



MASKING TAPE



PRIMER (WHITE)



SPRAY PAINT: BLACK & WHITE



SPRAY CLEAR COAT (OPTIONAL)



PLASTIC CEMENT



WAX PAPER

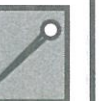

STRAIGHT PIN

1. ASSEMBLE ENGINE MOUNT

- A. MARK TUBE. B. CUT A 1/8" (3 mm) WIDE SLIT AT 1/4" (6 mm) MARK.
- D. APPLY GLUE JUST IN FRONT OF 3/4" (19 mm) MARK.
- F. APPLY GLUE BAND AROUND FRONT OF TUBE.

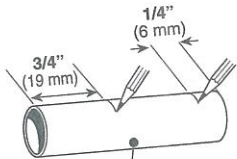

BLUE ENGINE MOUNT TUBE

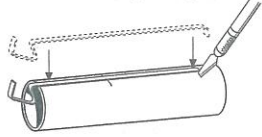

C. POSITION ENGINE HOOK.

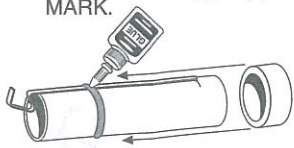

E. SLIDE GREEN ADAPTER RING ONTO ENGINE MOUNT TUBE DOWN TO THE 3/4" (19 mm) MARK.

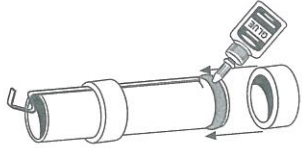

G. SLIDE OTHER GREEN ADAPTER RING SO IT IS EVEN WITH THE END OF THE TUBE.

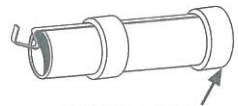

ENDS EVEN

2. BALSA SHEET LAYOUTS

- A. CUT OUT THE BALSA PATTERNS FROM THE PATTERN SHEET.

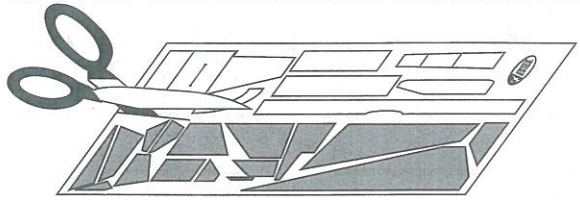

- B. ARRANGE PATTERNS AS SHOWN AND TRACE ON BALSA SHEETS.

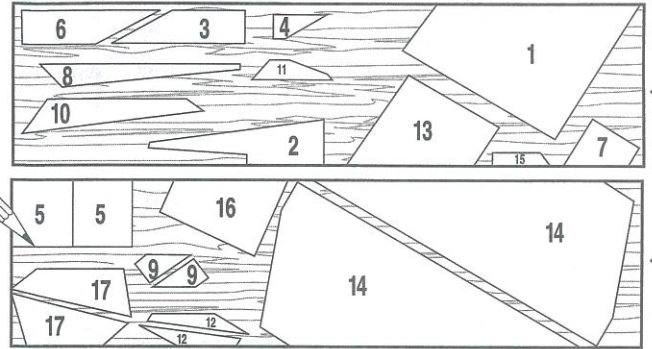

USE THIS LAYOUT FOR THE TWO 3/32" THICK BALSA SHEETS.

USE THIS LAYOUT FOR THE ONE 1/16" THICK BALSA SHEET.

3. FORWARD WING CONSTRUCTION

- A. USING A HOBBY KNIFE, CAREFULLY CUT PATTERN #1 AND PATTERN #2 FROM EACH 3/32" THICK BALSA SHEET.

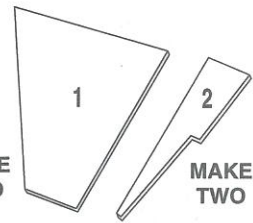

- B. GLUE EACH WING SECTION TOGETHER AS SHOWN. ALIGN BOTH ROOT EDGES.

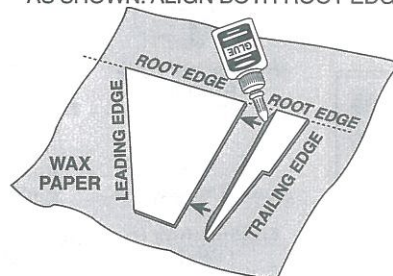

- C. LET DRY.

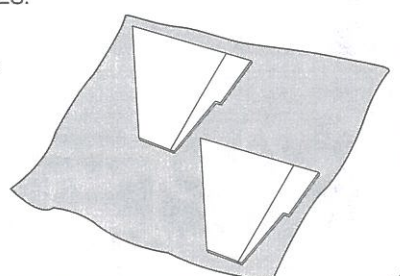

4. ASSEMBLE SCRAMJET TUBES

- A. APPLY A THIN STRAIGHT LINE OF GLUE ALONG ONE BT-5 BODY TUBE.
- B. ATTACH IT TO ANOTHER BT-5 TUBE SO THE TUBE ENDS ARE EVEN.
- C. REPEAT STEPS A & B FOR REMAINING BT-5 TUBES.

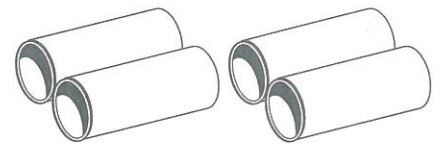
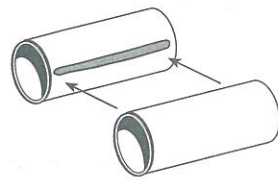
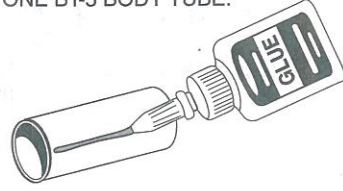

COMPLETED SCRAMJETS

5. PREPARE FORWARD WING

- A. CUT OUT WING MARKING GUIDE FROM PATTERN SHEET.



- B. PLACE BOTH WINGS ON A FLAT SURFACE. LAY WING MARKING GUIDE ON TOP OF WING, PRINTED SIDE UP. USING A PIN, POKE THROUGH PATTERN SHEET AT DOTS. DO NOT POKE ALL THE WAY THROUGH BALSA.

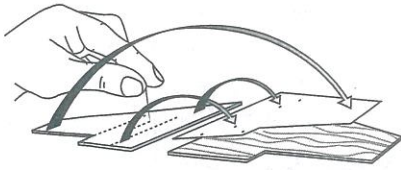

- C. CAREFULLY DRAW LINES TO CONNECT PINHOLES.

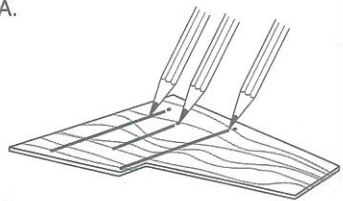

- C. FLIP PATTERN SHEET OVER ONTO OTHER WING AND REPEAT PROCESS TO MARK WING.

6. ASSEMBLE FORWARD WINGS

A. USING A HOBBY KNIFE, CAREFULLY CUT PATTERN #3 FROM EACH 3/32" THICK Balsa SHEET. SAND AS SHOWN.

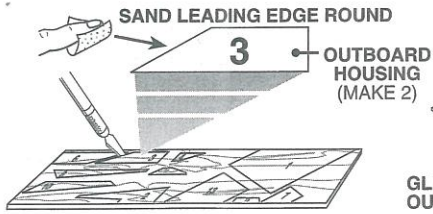

B. GLUE OUTBOARD HOUSING TO WING, AS SHOWN. HOUSING SHOULD BE PERPENDICULAR TO THE WING.

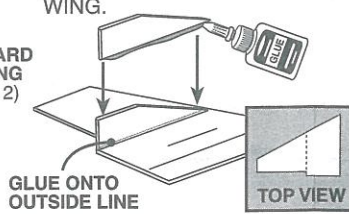

C. MARK ONE PAIR OF SCRAMJET TUBES 1/2" (13 mm) FROM END.

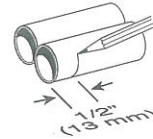

D. APPLY GLUE TO EACH TUBE FORWARD FROM 1/2" (13 mm) MARK. GLUE ONTO WING AGAINST HOUSING SO THAT 1/2" (13 mm) MARK IS EVEN WITH TRAILING EDGE.

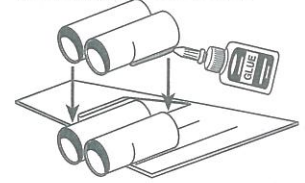

E. USING A HOBBY KNIFE, CAREFULLY CUT PATTERN #4 FROM EACH 3/32" THICK Balsa SHEET. SAND AS SHOWN.

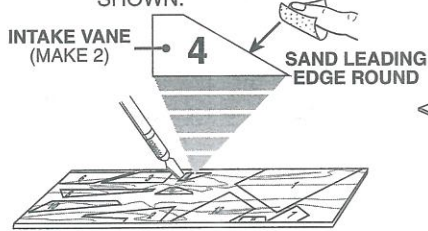

F. GLUE INTAKE VANE TO WING AS SHOWN.

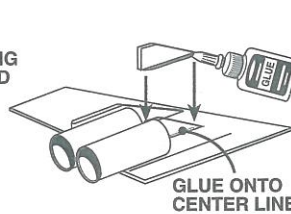

G. USING A HOBBY KNIFE, CAREFULLY CUT EACH PATTERN #5 FROM 1/16" THICK Balsa SHEET.

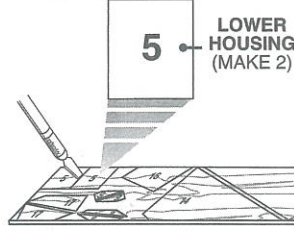

H. APPLY GLUE AS SHOWN AND POSITION LOWER HOUSING IN PLACE. EDGE OF HOUSING SHOULD REST SQUARELY AGAINST OUTBOARD HOUSING.

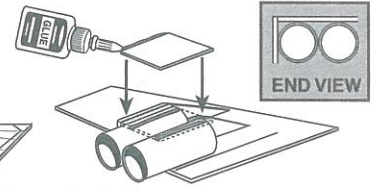

I. USING A HOBBY KNIFE, CAREFULLY CUT PATTERN #6 FROM EACH 3/32" THICK Balsa SHEET. SAND AS SHOWN.

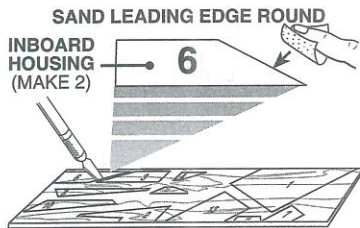

J. APPLY GLUE AS SHOWN AND POSITION HOUSING IN PLACE. INBOARD HOUSING SHOULD REST SQUARELY AGAINST LOWER HOUSING.

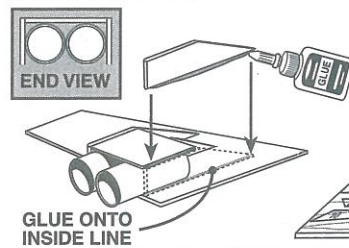

K. USING A HOBBY KNIFE, CAREFULLY CUT PATTERN #7 FROM EACH 3/32" THICK Balsa SHEET.

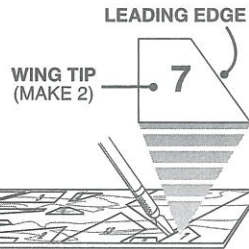

L. APPLY GLUE TO WING TIP. GLUE WING TIP ONTO OUTER EDGE OF WING.

M. REPEAT STEPS A THROUGH O FOR OTHER FORWARD WING.

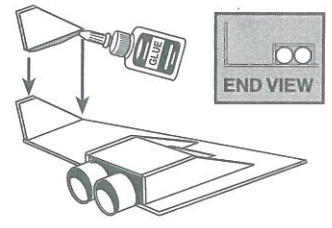

7. INSERT ENGINE MOUNT

A. MARK ENGINE MOUNT 1/2" (13 mm) FROM REAR.

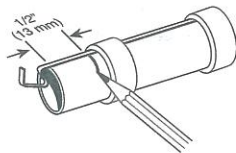

B. SMEAR GLUE INSIDE BOOSTER BODY TUBE.

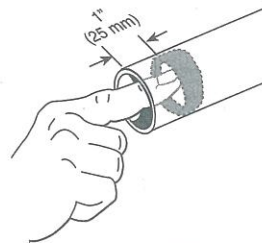

C. INSERT ENGINE MOUNT INTO BOOSTER TUBE UNTIL 1/2" (13 mm) MARK IS EVEN WITH BOOSTER TUBE END.

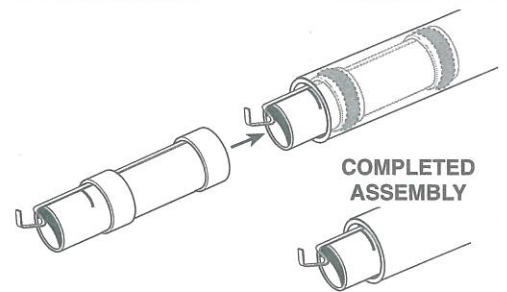

8. MARK BOOSTER BODY TUBE

A. CUT OUT THE BOOSTER MARKING GUIDE FROM THE PATTERN SHEET.

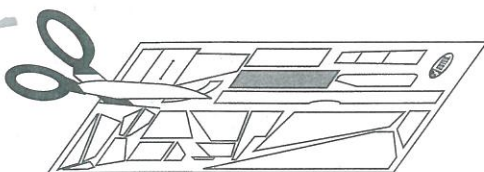

B. TAPE GUIDE AROUND BOOSTER BODY AND CENTER ENGINE HOOK BENEATH ARROW H. MARK TUBE AT ARROWS AND LABEL. REMOVE GUIDE.

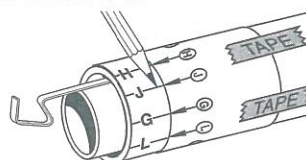

C. EXTEND MARKS J, K AND L 9" (22.9 cm). EXTEND MARKS AT G AND H ENTIRE LENGTH OF BODY TUBE. HELPFUL HINT: USE A DOOR FRAME TO DRAW LINES.

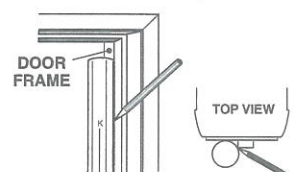

9. ASSEMBLE LAUNCH LUG

A. CUT TWO 5/8" (16 mm) PIECES FROM LAUNCH LUG.

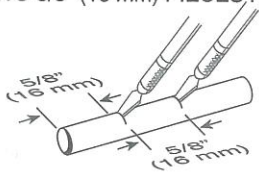

SAVE LEFTOVER PIECE OF LAUNCH LUG.

B. GLUE TWO 5/8" (16 mm) LAUNCH LUG PIECES TO BOOSTER BODY, CENTERED ON ALIGNMENT LINE H, AS SHOWN.

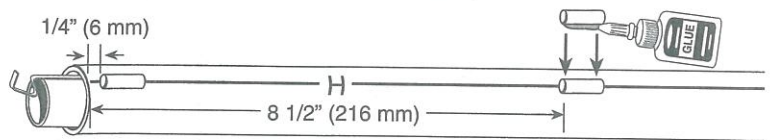

10. ATTACH FORWARD WINGS

A. SAND EACH WING ASSEMBLY, AS SHOWN.

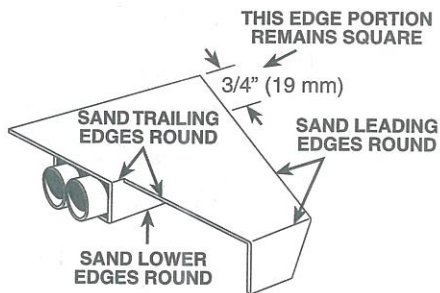

B. APPLY THIN LAYER OF GLUE. WAIT 1 MINUTE. APPLY 2ND THIN LAYER AND ATTACH WING CENTERED ON ALIGNMENT LINE G.

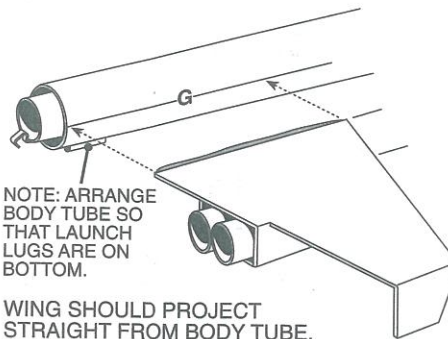

C. CUT OUT BOOSTER WING ALIGNMENT TEMPLATE FROM PATTERN SHEET.

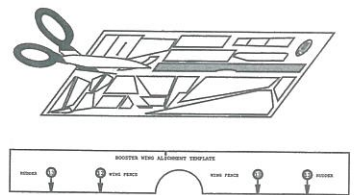

D. USE THE BOOSTER WING ALIGNMENT TEMPLATE TO ENSURE PROPER PLACEMENT, AND GLUE OTHER FORWARD WING TO BOOSTER TUBE.

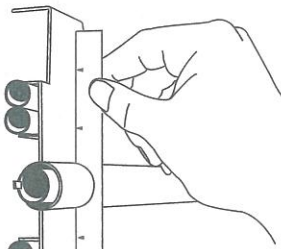

E. USING A HOBBY KNIFE, CAREFULLY CUT PATTERN #8 FROM EACH 3/32" THICK BALSA SHEET. SAND AS SHOWN.

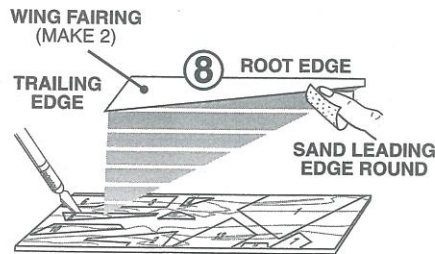

F. APPLY THIN LAYER OF GLUE TO ROOT & TRAILING EDGES. WAIT 1 MINUTE. APPLY A SECOND THIN LAYER AND ATTACH WING FAIRING CENTERED ON ALIGNMENT LINE G, FLUSH WITH WING.

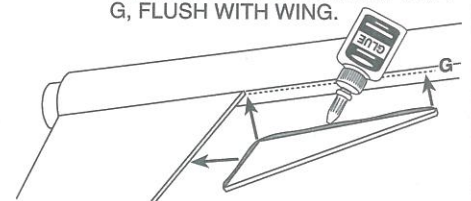

G. REPEAT FOR OTHER WING.

11. ATTACH CANARDS & ORBITER HOLDER

A. USING A HOBBY KNIFE, CAREFULLY CUT EACH PATTERN #9 FROM 1/16" THICK BALSA SHEET, SAND AS SHOWN.

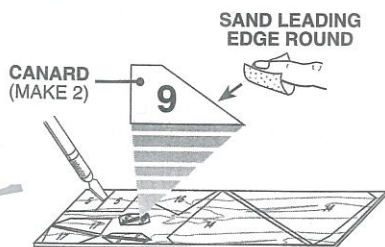

B. APPLY THIN LAYER OF GLUE. WAIT 1 MINUTE. APPLY 2ND THIN LAYER AND ATTACH CANARD CENTERED ON ALIGNMENT LINE G AS SHOWN.

REPEAT FOR CANARD ON OTHER SIDE OF BOOSTER TUBE.

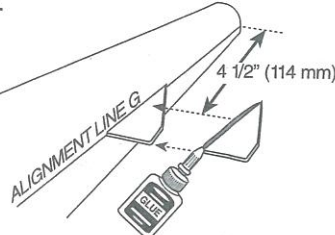

C. CUT 1/2" (13 mm) PIECE FROM REMAINDER OF LAUNCH LUG.

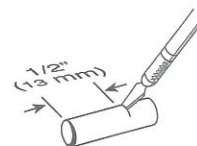

D. GLUE LAUNCH LUG PIECE CENTERED ONTO ALIGNMENT LINE K, AS SHOWN.

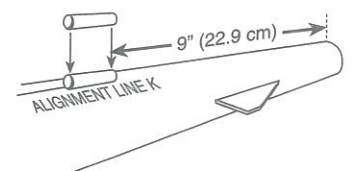

12. APPLY FILLETS & ATTACH VERTICAL WINGS

- A. APPLY GLUE FILLETS TO WING BODY TUBE JOINTS.
 B. SMOOTH WITH FINGERS.

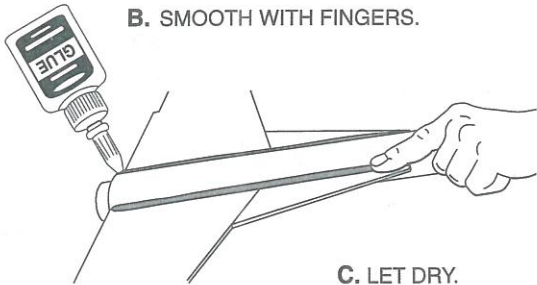

C. LET DRY.

- D. USING A HOBBY KNIFE, CAREFULLY CUT PATTERN #10 FROM EACH 3/32" THICK Balsa SHEET. SAND AS SHOWN.

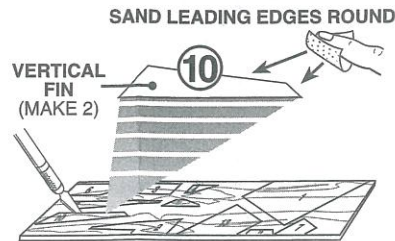

- D. APPLY A THIN LAYER OF GLUE. WAIT 1 MINUTE. APPLY 2ND LAYER AND ATTACH EACH VERTICAL FIN CENTERED ON ALIGNMENT LINES J.

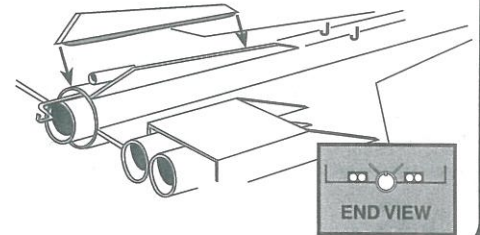

13. ATTACH GLIDER SUPPORTS

- A. USING A HOBBY KNIFE, CAREFULLY CUT PATTERN #11 OUT OF EACH 3/32" THICK Balsa SHEET. SAND AS SHOWN.

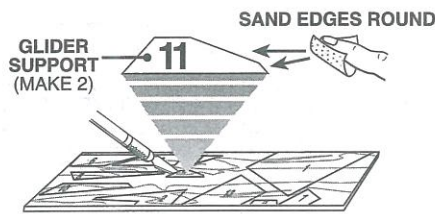

- B. APPLY THIN LAYER OF GLUE. WAIT 1 MINUTE. APPLY 2ND THIN LAYER AND ATTACH GLIDER SUPPORT CENTERED ON ALIGNMENT LINE L, AS SHOWN.

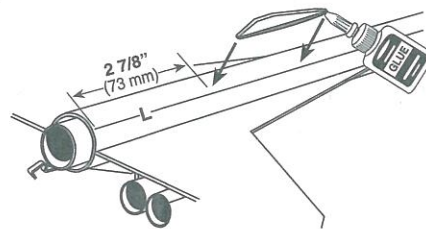

- C. REPEAT STEP B FOR REMAINING GLIDER SUPPORT.

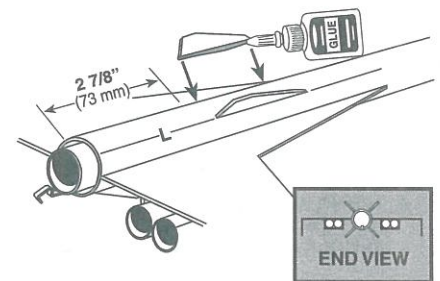

14. ATTACH WING FENCES & RUDDERS

- A. USE WING TEMPLATE TO MARK WINGS. POSITION TEMPLATE AS SHOWN AND MARK WINGS AT ARROWS. MOVE TEMPLATE FORWARD 2 1/2" (64 mm) AND MARK WINGS AT ARROWS.

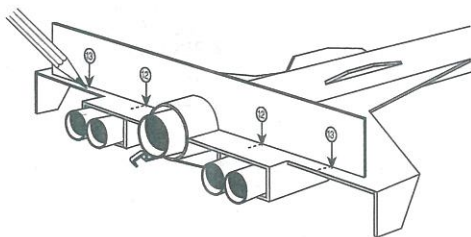

- B. USE A STRAIGHT EDGE TO CONNECT MARKS.

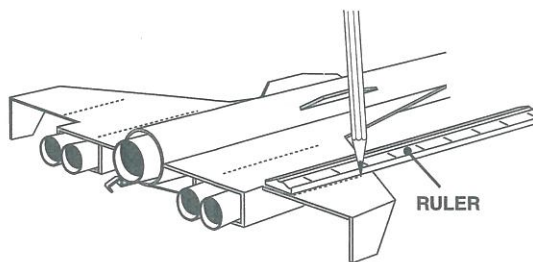

- C. USING A HOBBY KNIFE, CAREFULLY CUT PATTERN #12 FROM 1/16" THICK Balsa SHEET. SAND ALL EDGES SQUARE.

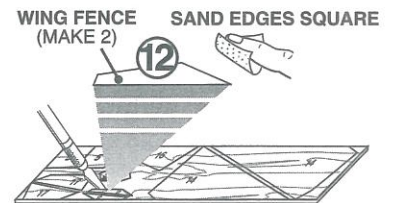

- D. GLUE EACH WING FENCE, CENTERED ON INSIDE LINE, TO WINGS. REAR OF WING FENCE SHOULD BE EVEN WITH REAR OF WING. FENCES SHOULD BE VERTICAL TO WING.

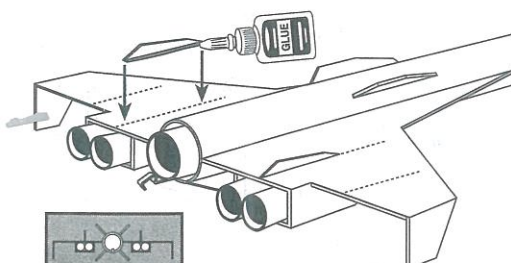

- E. USING A HOBBY KNIFE, CAREFULLY CUT PATTERN #13 FROM 3/32" THICK Balsa SHEET, SAND AS SHOWN.

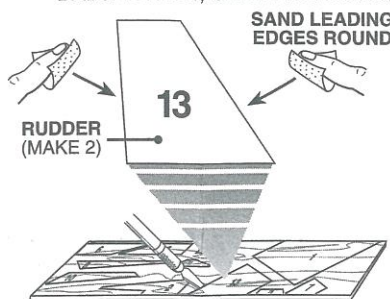

- F. GLUE EACH RUDDER, CENTERED ON OUTSIDE LINE, TO WINGS. REAR OF RUDDER SHOULD BE EVEN WITH REAR OF WING AND VERTICAL TO WING.

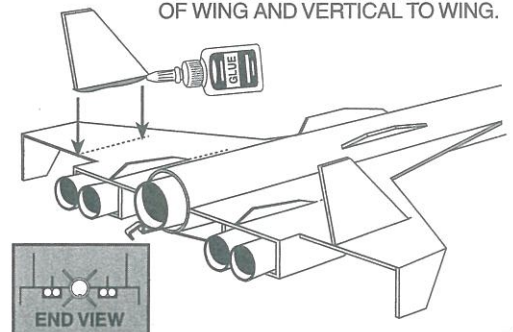

15. ATTACH SHOCK CORD

A. CUT OUT SHOCK CORD MOUNT FROM PATTERN SHEET.

B. SMEAR GLUE. FOLD FORWARD.

C. SMEAR GLUE. FOLD FORWARD.

D. SQUEEZE TIGHTLY.

E. GLUE MOUNT 1" (25 mm) INSIDE BODY TUBE. HOLD UNTIL GLUE SETS.

16. ASSEMBLE NOSE CONE & RECOVERY SYSTEM

A. USE PLASTIC CEMENT TO GLUE NOSE CONE INSERT INTO NOSE CONE. LET DRY.

B.

C.

D.

SHOCK CORD

DOUBLE KNOT SHOCK CORD.

17. ASSEMBLE GLIDER WINGS

A. USING A HOBBY KNIFE, CAREFULLY CUT EACH PATTERN #14 FROM 1/16" THICK Balsa SHEET. SAND AS SHOWN.

B. PLACE GLIDER BODY TUBE ON FLAT SURFACE AND COVER WITH A PIECE OF WAX PAPER.

C. APPLY THIN LAYER OF GLUE. WAIT 1 MINUTE. APPLY 2ND THIN LAYER AND ATTACH WING PIECES TOGETHER. PLACE THE ASSEMBLY OVER THE GLIDER TUBE AS SHOWN. LOWER WINGTIPS UNTIL THEY REST ON THE FLAT SURFACE. WING JOINT SHOULD RUN STRAIGHT ALONG TOP OF BODY TUBE.

D. ALLOW GLUE TO DRY COMPLETELY BEFORE MOVING ON TO NEXT STEP.

GLIDER WING (MAKE 2)

14

SAND LEADING EDGE ROUND

WAX PAPER

GLIDER BODY TUBE

JOINT WINGTIP

END VIEW

18. ASSEMBLE GLIDER BODY

A. CUT OUT GLIDER MARKING GUIDE AND TAPE IT AROUND GLIDER BODY TUBE. MARK AND LABEL AT ARROWS.

B. EXTEND MARKS ENTIRE LENGTH OF GLIDER TUBE.

C. SMEAR PLASTIC CEMENT 1/4" (6 mm) INSIDE BODY TUBE AND INSERT NOSE CONE.

D. APPLY GLUE TO INSIDE WING JOINT. PRESS GLIDER TUBE INTO GLUE ALONG ALIGNMENT LINE M. REAR OF BODY TUBE SHOULD BE EVEN WITH REAR OF WING ASSEMBLY.

E. PLACE ASSEMBLY UPSIDE DOWN WHILE GLUE DRIES.

GLIDER MARKING GUIDE

DOOR FRAME

1/4" (6 mm)

M

19. ATTACH GLIDER SUPPORT

A. USING A HOBBY KNIFE, CAREFULLY CUT ONE PATTERN #15 FROM 3/32" THICK Balsa SHEET. SAND AS SHOWN.

B. SAND ONE END OF WOOD DOWEL TO A 45° ANGLE. GLUE TO SUPPORT AS SHOWN.

C. GLUE ASSEMBLY TO BODY TUBE CENTERED ON ALIGNMENT LINE M.

SUPPORT (MAKE 1)

15

SAND EDGE ROUND

45°

GLUE

M

PLACE REAR OF SUPPORT AGAINST WING

20. FINISH GLIDER CONSTRUCTION

A. CUT OUT NOZZLE SHROUD FROM PATTERN SHEET.



B. APPLY GLUE TO THE TAB AND PRESS IT INTO POSITION. HOLD IT UNTIL GLUE SETS.

C. USING A HOBBY KNIFE, CAREFULLY CUT PATTERN #16 FROM 1/16" THICK Balsa SHEET. SAND AS SHOWN.

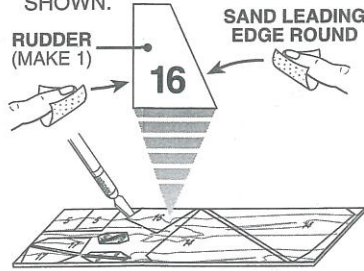

D. APPLY THIN LAYER OF GLUE. WAIT 1 MINUTE. APPLY 2ND THIN LAYER AND ATTACH RUDDER TO GLIDER CENTERED ON ALIGNMENT LINE N AND EVEN WITH END OF TUBE.

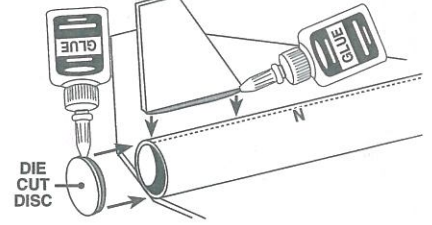

E. APPLY GLUE TO DIE CUT DISC NB-20 AND ATTACH TO REAR OF BODY TUBE.

F. APPLY GLUE AROUND SMALL END OF NOZZLE SHROUD AND ATTACH TO THE DIE CUT DISC NB-20.

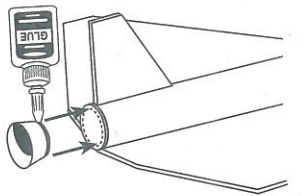

CENTER NOZZLE SHROUD ONTO DIE CUT DISC NB-20.

G. USING A HOBBY KNIFE, CAREFULLY CUT PATTERN #17 FROM 1/16" THICK Balsa SHEET.

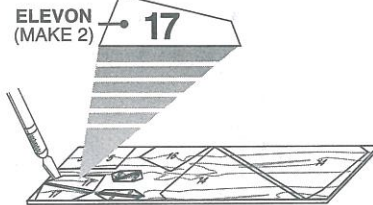

H. CUT OUT ELEVON GUIDE FROM PATTERN SHEET. USE IT TO ALIGN ELEVONS WHEN GLUING TO WINGS.

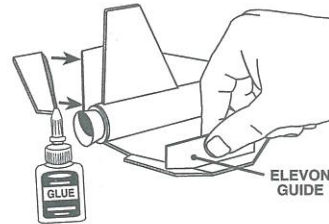

I. APPLY THIN LAYER OF GLUE. WAIT 1 MINUTE. APPLY 2ND THIN LAYER AND ATTACH ELEVONS TO WINGS.

J. APPLY GLUE FILLET TO WING JOINT AND GLIDER SUPPORT. SMOOTH WITH FINGERTIP AND LET DRY.

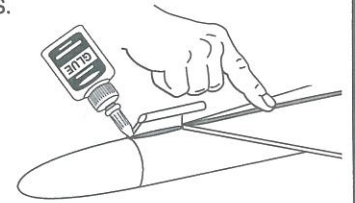

21. TEST GLIDER

A. GENTLY HAND LAUNCH GLIDER FROM SHOULDER HEIGHT. A GLIDE OF ABOUT 10-15 FEET (3-5 m) IS NORMAL WITH LITTLE OR NO WIND. AFTER SEVERAL LAUNCHES, IF THE GLIDER TENDS TO STALL, DIVE OR TURN SHARPLY, ADJUST THE ELEVONS, AS SHOWN.

B. TO CHANGE ELEVON POSITION, HOLD ELEVON HINGE JOINT CLOSE TO A LIGHTED LIGHT BULB, THE HEAT WILL SOFTEN THE GLUE JOINT ENOUGH TO PERMIT MOVEMENT UP OR DOWN, MOVE ELEVON CAREFULLY TO PREVENT BREAKING IT. HOLD ELEVON IN NEW POSITION AND BLOW ON JOINT UNTIL THE GLUE HAS RESET (ABOUT 5-10 SECONDS). RESET GLIDER AND REPEAT UNTIL GLIDE IS CORRECT.

CORRECT GLIDE
NO CHANGE NECESSARY



STALL
LOWER BOTH ELEVONS



DIVE
RAISE BOTH ELEVONS



EXCESS TURNS
LOWER ELEVON AS SHOWN



PAINT SCHEME SPRAY ENTIRE ROCKET WITH PRIMER, LET DRY AND SAND. REPEAT UNTIL ROCKET IS SMOOTH.

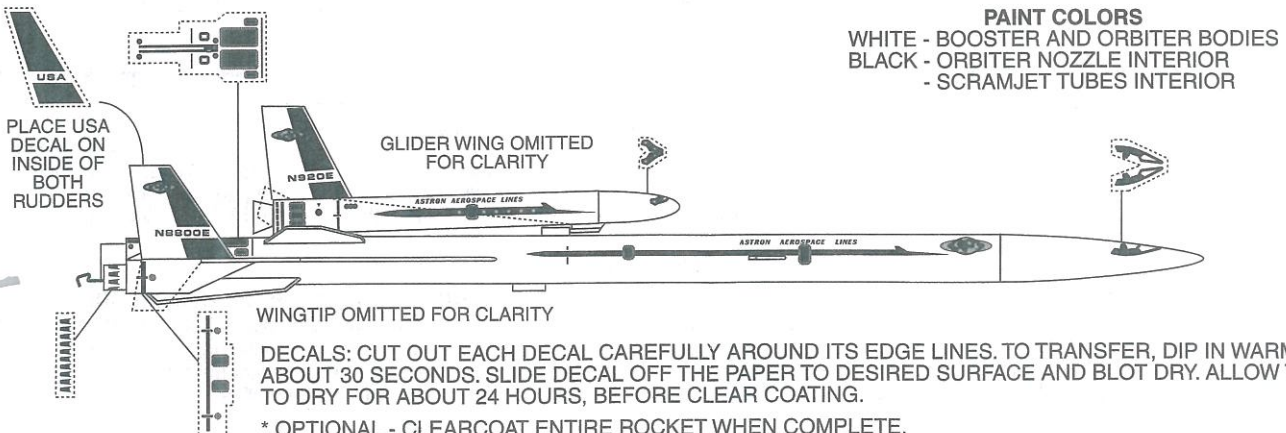

PAINT COLORS
WHITE - BOOSTER AND ORBITER BODIES
BLACK - ORBITER NOZZLE INTERIOR
- SCRAMJET TUBES INTERIOR

DECALS: CUT OUT EACH DECAL CAREFULLY AROUND ITS EDGE LINES. TO TRANSFER, DIP IN WARM WATER FOR ABOUT 30 SECONDS. SLIDE DECAL OFF THE PAPER TO DESIRED SURFACE AND BLOT DRY. ALLOW THE DECALS TO DRY FOR ABOUT 24 HOURS, BEFORE CLEAR COATING.

* OPTIONAL - CLEARCOAT ENTIRE ROCKET WHEN COMPLETE.

ROCKET PREFLIGHT

A. INSERT 4 OR 5 LOOSELY CRUMPLED SQUARES OF RECOVERY WADDING.

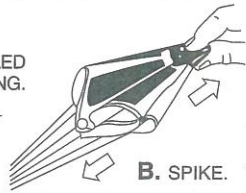

B. SPIKE.



C. FOLD.

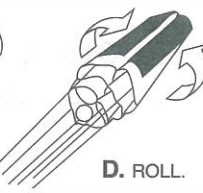

D. ROLL.

E. WRAP LINES LOOSELY, INSERT PARACHUTE, SHOCK CORD AND NOSE CONE INTO BOOSTER TUBE.

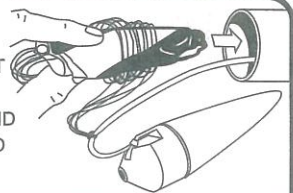

WARNING: FLAMMABLE

To avoid serious injury, read instructions & NAR Safety Code included with engines.
PREPARE YOUR ENGINE ONLY WHEN YOU ARE OUTSIDE AT THE LAUNCH SITE PREPARING TO LAUNCH!
 If you do not use your prepared engine, remove the igniter before storing your engine.

A.



B. TIP MUST TOUCH PROPELLANT.



C.



D.



E.

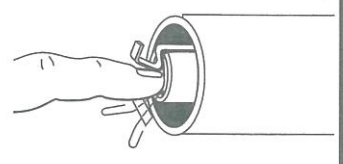

F. INSERT ENGINE INTO ROCKET.

COUNTDOWN AND LAUNCH

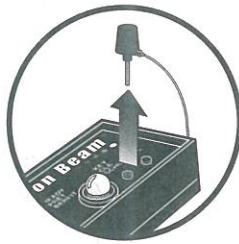

KEY ALWAYS OUT UNTIL FINAL COUNTDOWN!

LAUNCH SUPPLIES

(sold separately):

- Porta-Pad® II Launch Pad
- Electron Beam® Launch Controller
- Recovery Wadding
- Igniters (w/ engines)
- Igniter Plugs (w/ engines)
- Recommended Estes® Engines: B4-2, B4-4, B6-2, B6-4, C6-3, C6-5.

ORBITER SEPARATES AT APOGEE AND GLIDES BACK.

TRANSPORT BOOSTER RETURNS VIA PARACHUTE.

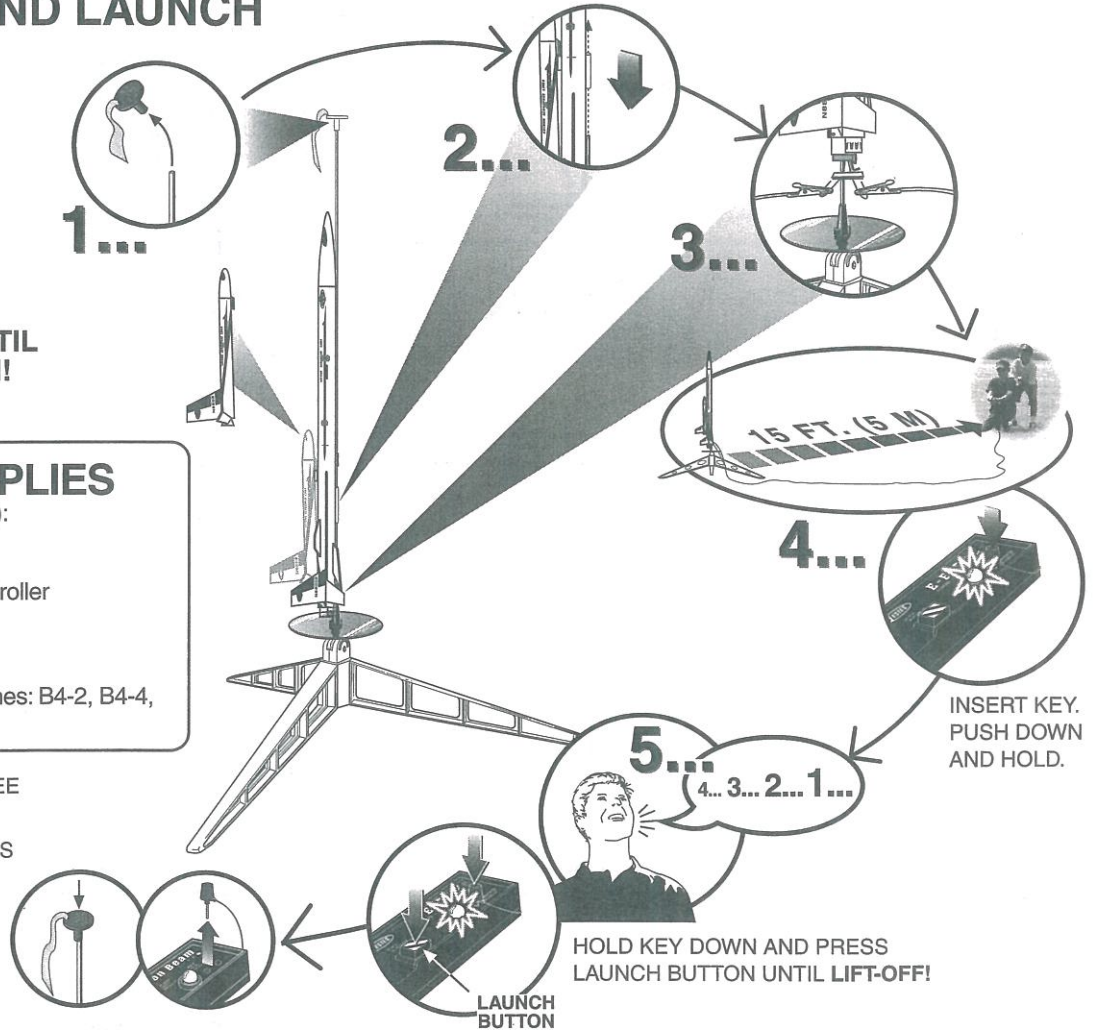

PRECAUTIONS

NAR Safety Code



NO DRY GRASS OR WEEDS

FLYING YOUR ROCKET

Choose a large field (500 ft. [152 m] square) free of dry weeds and brown grass. The larger the launch area, the better your chance of recovering your rocket. Football fields and playgrounds are great. Launch only with little or no wind and good visibility. Always follow the National Association of Rocketry (NAR) SAFETY CODE (enclosed).

MISFIRES

TAKE THE KEY OUT OF THE CONTROLLER. WAIT ONE MINUTE BEFORE GOING NEAR THE ROCKET! Take the plug and igniter out of the engine. If the igniter has burned, it worked but did not ignite the engine because it was not touching the propellant inside the engine. Put a new igniter all the way inside the engine without bending it. Push the plug in place. Repeat the steps under Countdown and Launch.