

U.S.S. ENTERPRISE

FLYING MODEL ROCKET ASSEMBLY INSTRUCTION
SKILL LEVEL 4 - COMPLEX ROCKET

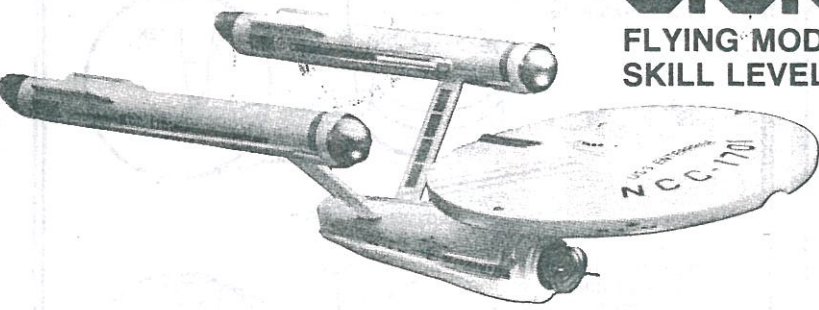

U.S.S. ENTERPRISE PARTS LIST

KIT NO. 1275

- A) 1 Vacuum-Formed Plastic Parts Sheet - type PF-75
- B) 1 Pattern Sheet - type SP-75
- C) 1 Support Ring - type RT-99D (3.7" - 94 mm dia.)
- D) 2 Tube Coupler - type JT-50C (1.0" - 25 mm long)
- E) 2 Plywood Die-Cut Sheet - type BF-75
- F) 3 1/12" (2 mm) Diameter Dowel - type WD-2B (6" - 15.2 cm long)
- G) 2 Propulsion Unit Tube - type BT-50H (7 3/4" - 19.7 cm long)
- H) 1 Card Die-Cut Sheet - type TA-75
- I) 1 Engine Mount Tube - type BT-20DJ (4" - 10.2 cm long)
- J) 2 Engine Hook - type EH-2
- K) 2 Retainer Rings - type HR-20 (5/16" - 8 mm long)
- L) 1 Tube Coupler - type JT-20C (3/4" - 19 mm long)
- M) 2 1/8" (3 mm) Diameter Dowel - type WD-1 (18" - 45.7 cm long)
- N) 1 Probe Body Tube - type BT-20 (18" - 45.7 cm long)
- O) 1 Launch Lug - type LL-2B (2 3/8" - 60 mm long)
- P) 2 Adapter Rings - type AR-2050
- Q) 1 Parachute Compartment Tube - type BT-50L (12.7" - 32.3 cm long)
- R) 1 Shock Cord
- S) 1 Screw Eye - type SE-2A
- T) 1 Nose Cone - type BNC-50J
- U) 2 Nose Cone Weights - type NCW-1A
- V) 1 Parachute - type PK-18A
- W) 1 Shroud Line Thread - type SLT-108 (108" - 274 cm)
- X) 6 Tape Discs - type TD-3F
- Y) 1 Decal - type KD-75

PARTS IDENTIFICATION

NOTE: WHEN ASSEMBLING THE STAND, IT MAY BE NECESSARY TO ENLARGE SLOTS FOR ACCURATE FIT

In addition to the parts in this kit, you will need:

SCISSORS	PENCIL	RULER	PAINT BRUSH	HOBBY KNIFE	SANDPAPER	YELLOW CARPENTERS GLUE	ENAMEL SPRAY PAINT (Camouflage Gray)	LIQUID PLASTIC CEMENT	MASKING TAPE	PLASTIC CEMENT	ENAMEL PAINT (dark gray, red, green, copper, black)	CYANACRYLATE ADHESIVE (Instant glue)

ASSEMBLY INSTRUCTIONS

IMPORTANT:

Read all instructions before beginning work on your Enterprise. When you are thoroughly familiar with the construction sequence, begin construction. Check off each step as you complete it. Use yellow carpenter's glue unless instructed to use liquid plastic cement or slow-setting instant glue. To insure a good joint, wash and rinse plastic parts before assembling. Also, be sure plastic parts are completely dry prior to assembly.

NOTE: In each step as you assemble this model, test-fit the parts together before applying any glue. If any part doesn't fit properly, sand lightly or build up as appropriate for precision assembly.

TRIMMING & SANDING

- 1 Identify the parts shown below.

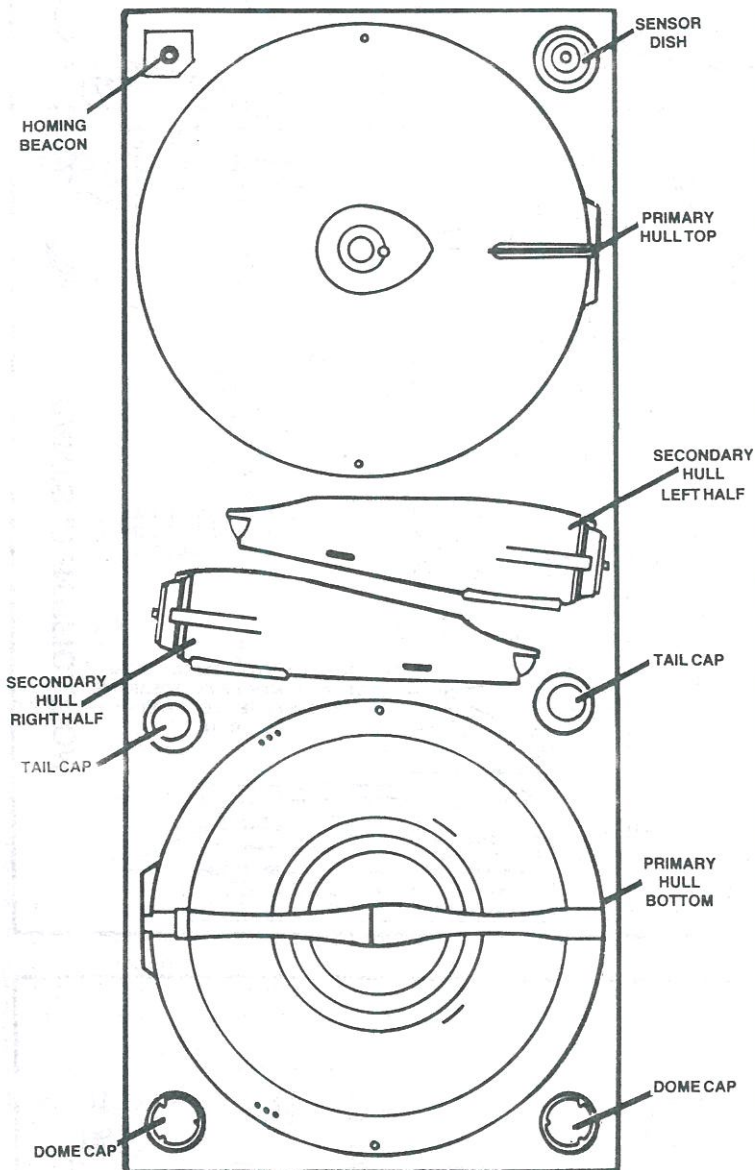

DRAW LINE AROUND PART WITH PEN AS SHOWN

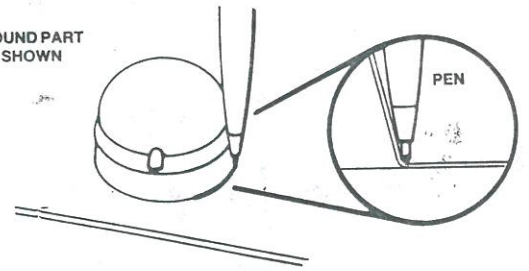

SCORE PARTLY THROUGH ON LINE WITH KNIFE AS SHOWN

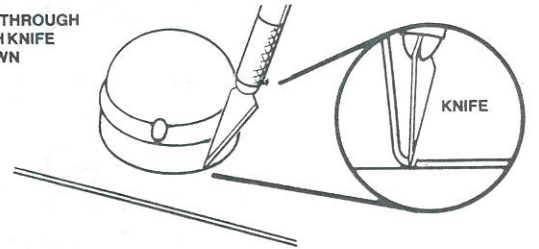

- 2 Trim the plastic parts using the "score and break" method. First, draw around the part as shown with a ball-point pen. Then trace along the line with a knife or single edge blade. Make a second pass along the same line, this time pressing down a bit harder. Repeat a third and a fourth time until you have cut about halfway into the plastic sheet. **IMPORTANT: DO NOT** attempt to cut all the way through the plastic. Work with one part at a time.

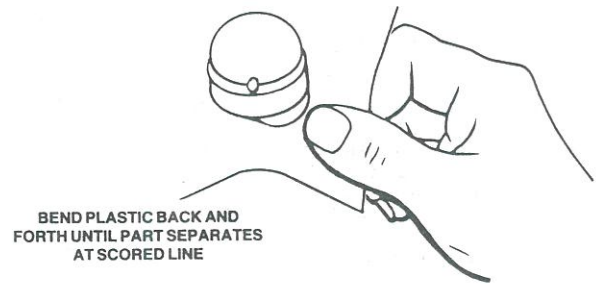

Starting at any point along the edge, bend the excess plastic back and forth until it separates along the score line. Work carefully around the entire part. If the plastic does not break easily, score lightly and bend again. Should an accidental break occur, simply apply liquid plastic cement to the damaged area and allow to dry. Then separate the plastic part properly.

NOTE: When removing the left half of the secondary hull, do not cut off the flange from the perimeter of the plastic.

CUT OUT PORTIONS SHOWN FOR SUPPORT PYLONS

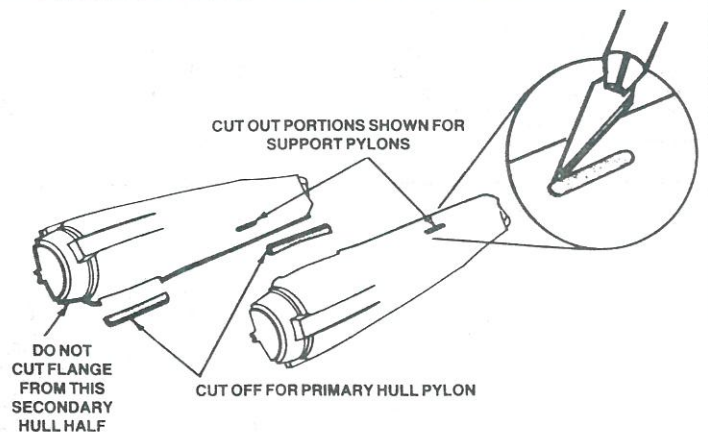

- 3 On the primary hull sections, cut out the sections for the hull pylon as shown in the drawing. Also remove the plastic from the area for the support pylons.

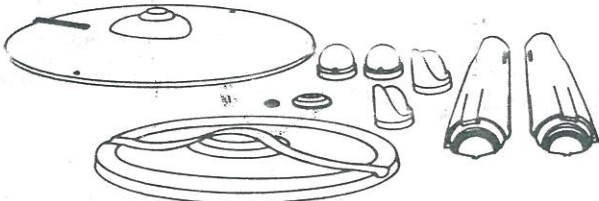

PARTS SHOWN ABOVE ARE COMPLETELY TRIMMED AND READY FOR SANDING

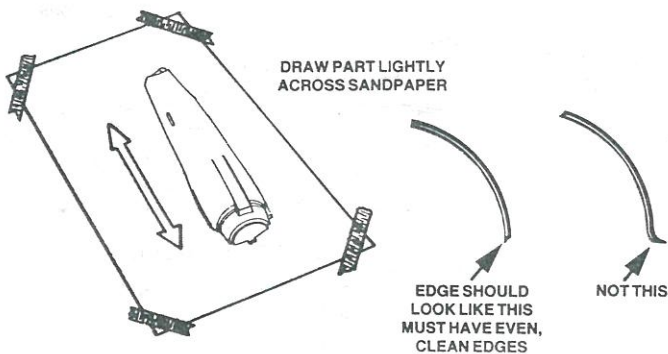

DRAW PART LIGHTLY ACROSS SANDPAPER

EDGE SHOULD LOOK LIKE THIS MUST HAVE EVEN, CLEAN EDGES NOT THIS

4 Tape a sheet of fine sandpaper to a table top or other flat surface. Draw the trimmed edge of each part lightly back and forth across the sheet several times to remove any burrs or rough edges. Sand only until you can see that you have an even, clean edge on each part. Final sanding on the primary hull and secondary hull pieces will be done after gluing.

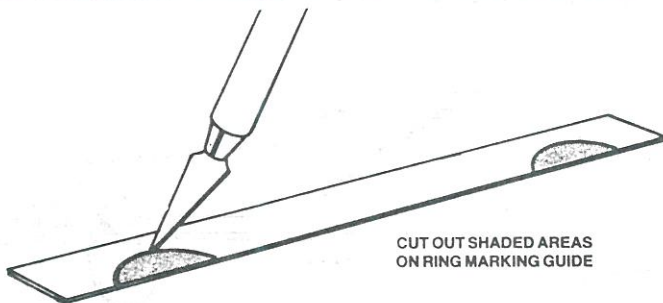

CUT OUT SHADED AREAS ON RING MARKING GUIDE



WRAP GUIDE ONTO RING AND MARK CUT OUT

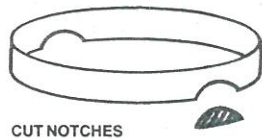

CUT NOTCHES

5 Cut out the ring marking guide from the pattern sheet. Cut the shaded areas out of the marking guide as shown. Position it on the support ring, and mark the cut-out areas. Carefully cut the half circles from the ring which you just marked.

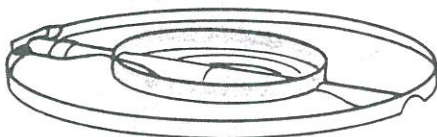

GLUE RING TO BOTTOM HALF

6 Apply slow-setting instant glue to the notched edge of the support ring. Press the ring in place on the inside of the bottom half of the primary hull so it is centered.

HULL, TOP HALF

APPLY LIQUID PLASTIC CEMENT ALONG JOINT

RING IS GLUE WITH SLOW-SETTING INSTANT GLUE TO TOP HALF

7 Test fit the upper half of the primary hull. If necessary, sand the edge of the lower half until the two pieces fit neatly together. Apply slow-setting instant glue to the upper edge of the support ring and join the upper and lower primary hull halves. Apply liquid plastic cement to the joint between upper and lower halves all around.

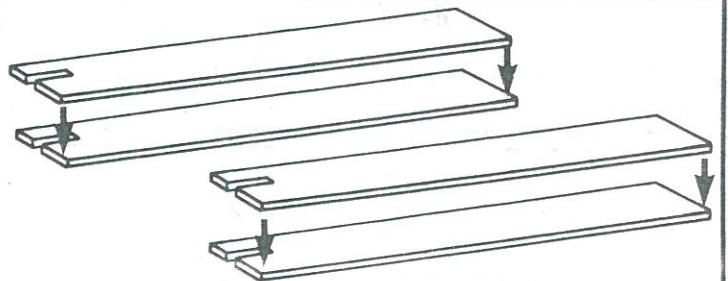

8 Use a sharp knife to free the four engine support pylons from the plywood sheet. Glue two together to make a single pylon. Repeat to make a second pylon.

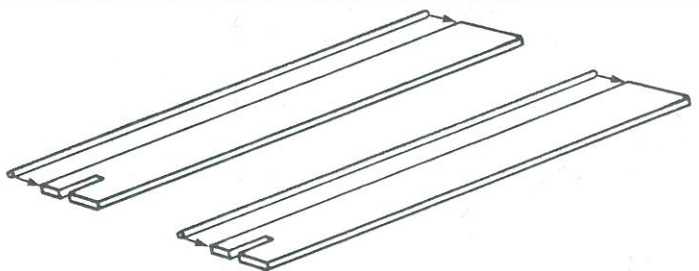

9 Cut two pieces of the small dowel to the same length as the pylons. Glue a dowel to one edge of each pylon piece. When the glue is dry, sand the sides and the front and rear edges of the pylon assemblies until smooth.

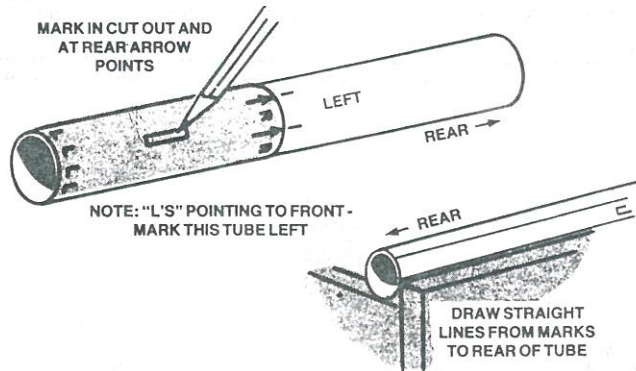

MARK IN CUT OUT AND AT REAR ARROW POINTS

LEFT

REAR

NOTE: "L'S" POINTING TO FRONT - MARK THIS TUBE LEFT

REAR

DRAW STRAIGHT LINES FROM MARKS TO REAR OF TUBE

10 Cut out the propulsion unit marking guide from the pattern sheet. Cut the rectangle "pylon cut-out" from the center of the marking guide. Wrap the guide around a propulsion unit tube so edge "L" is even with one end, and mark the tube at each arrow point on the other end of the guide. Mark also around the inside edges of the cut out area. Write "left" on this tube. Wrap the guide around the other propulsion unit tube so edge "R" is even with one end and mark the same way. Write "right" on this tube. Extend a straight line to the far end (rear) of the tube from each mark. (A door jamb or the notched edge of a drawer front makes an excellent guide.) Extend the line nearest the pylon cut out area the entire length of the tube.

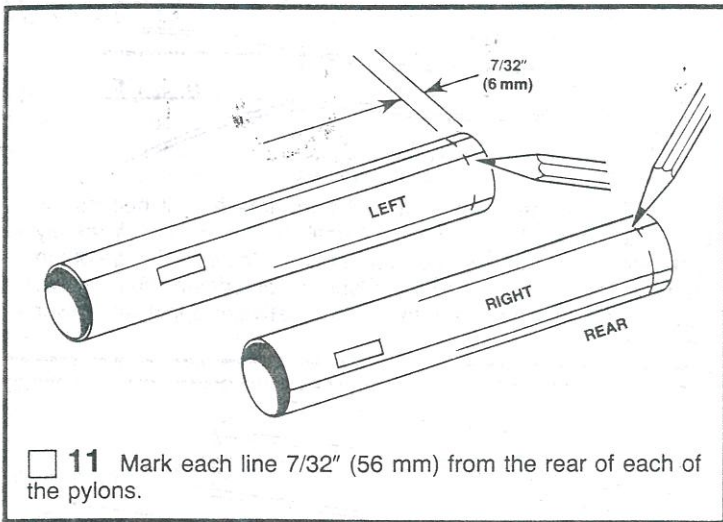

11 Mark each line 7/32" (6 mm) from the rear of each of the pylons.

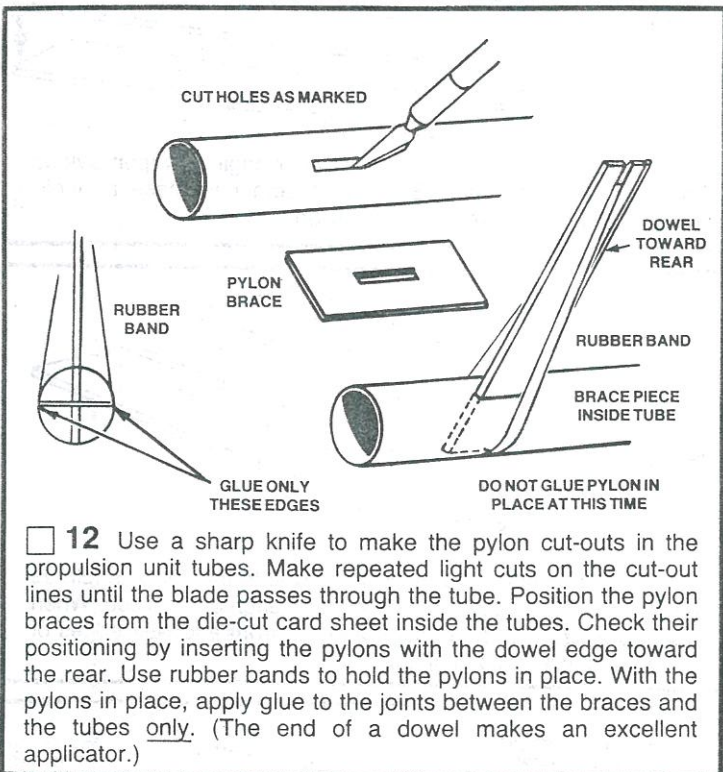

12 Use a sharp knife to make the pylon cut-outs in the propulsion unit tubes. Make repeated light cuts on the cut-out lines until the blade passes through the tube. Position the pylon braces from the die-cut card sheet inside the tubes. Check their positioning by inserting the pylons with the dowel edge toward the rear. Use rubber bands to hold the pylons in place. With the pylons in place, apply glue to the joints between the braces and the tubes only. (The end of a dowel makes an excellent applicator.)

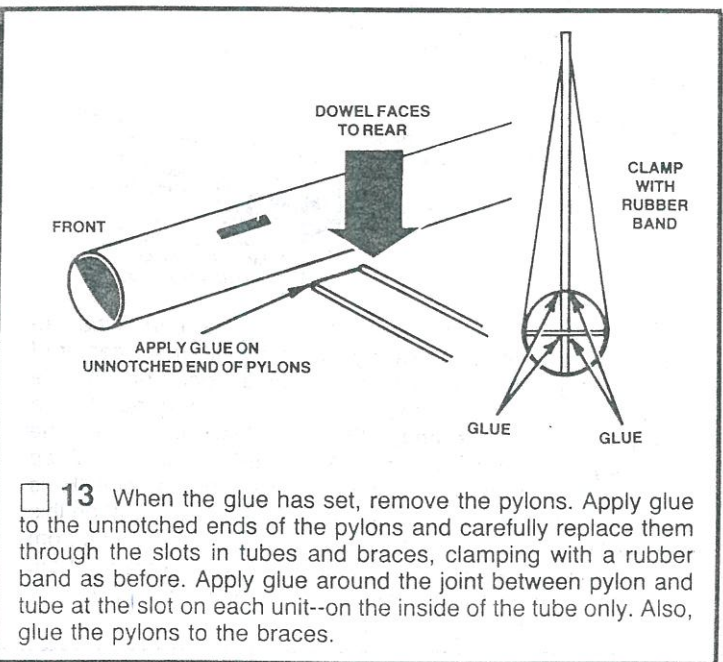

13 When the glue has set, remove the pylons. Apply glue to the unnotched ends of the pylons and carefully replace them through the slots in tubes and braces, clamping with a rubber band as before. Apply glue around the joint between pylon and tube at the slot on each unit--on the inside of the tube only. Also, glue the pylons to the braces.

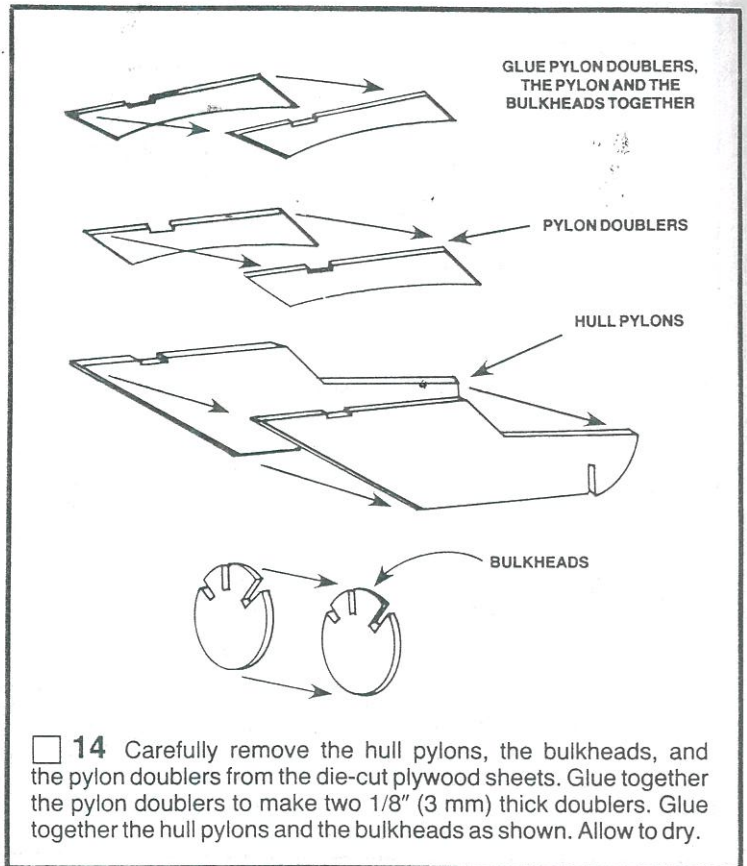

14 Carefully remove the hull pylons, the bulkheads, and the pylon doublers from the die-cut plywood sheets. Glue together the pylon doublers to make two 1/8" (3 mm) thick doublers. Glue together the hull pylons and the bulkheads as shown. Allow to dry.

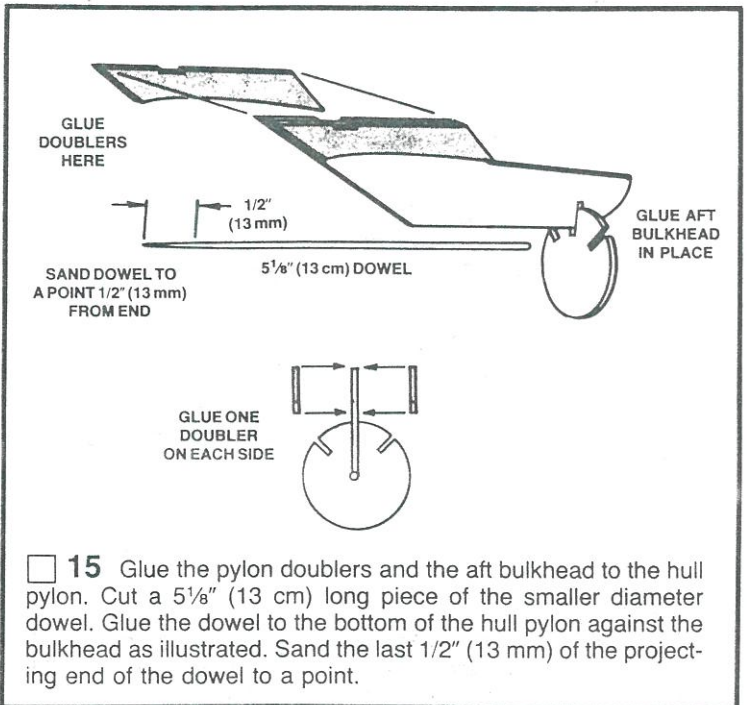

15 Glue the pylon doublers and the aft bulkhead to the hull pylon. Cut a 5 1/8" (13 cm) long piece of the smaller diameter dowel. Glue the dowel to the bottom of the hull pylon against the bulkhead as illustrated. Sand the last 1/2" (13 mm) of the projecting end of the dowel to a point.

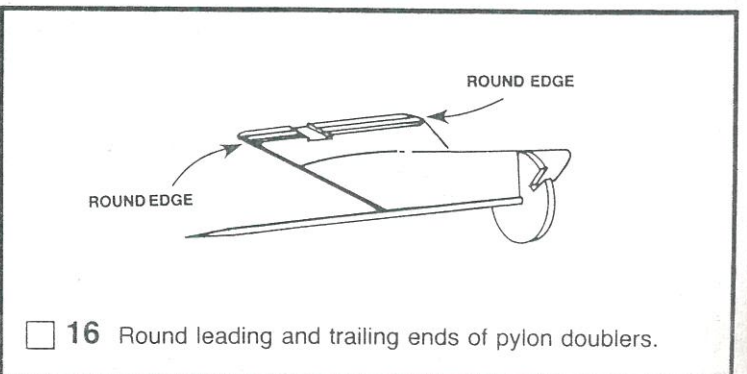

16 Round leading and trailing ends of pylon doublers.

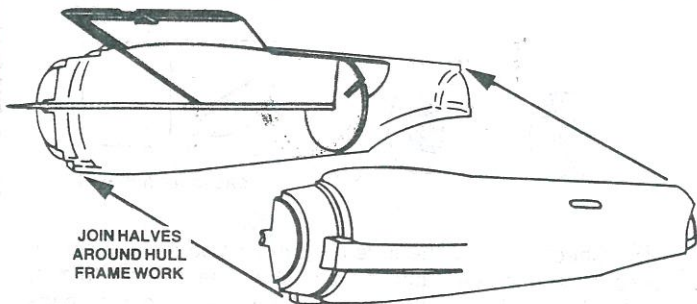

17 Test fit the secondary hull halves together on the hull framework assembled in step 16. Sand parts as necessary until the parts fit together precisely. Use liquid plastic cement to join the two halves around the framework. After the cement has dried, sand away any excess material on the seam.

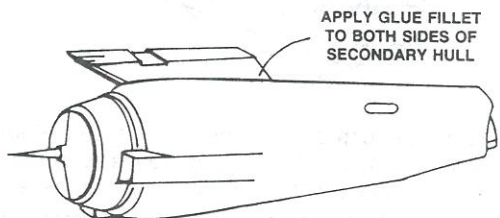

18 Apply glue fillet around the pylon where it intersects the secondary hull. Allow glue to dry.

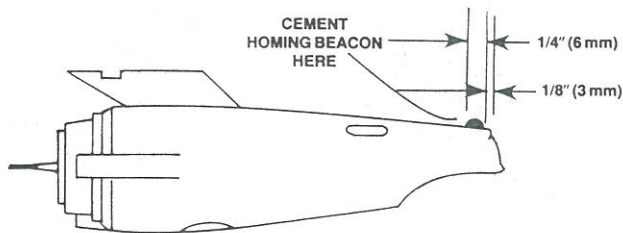

19 Carefully sand away the entire flange on the top of the secondary hull 1/4" (6 mm) wide, 1/8" (3 mm) from the rear of the hull. Do not sand into the hull itself. Cement the homing beacon in place in this area.

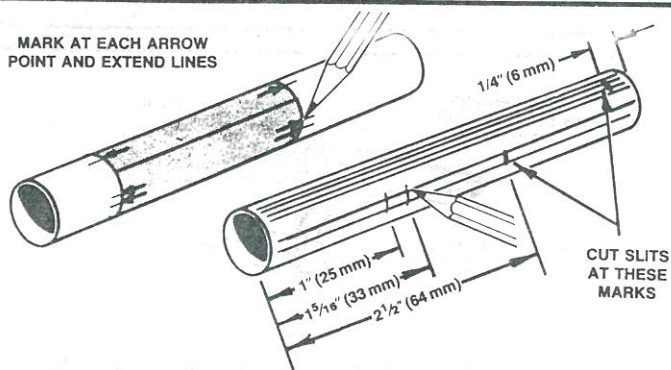

20 Cut out the engine mount marking guide from the pattern sheet. Wrap it around the engine mount tube and mark at each arrow point. Extend a straight pencil line the length of the tube through each matching front and rear mark. Mark the double line 1" (25 mm), 1 5/16" (33 mm), and 2 1/2" (64 mm) from one end. Mark the center pair of the four parallel lines 1/4" (6 mm) from the other end. Cut a 1/8" (3 mm) slit in the tube at the 2 1/2" (64 mm) and 1/4" (6 mm) marks.

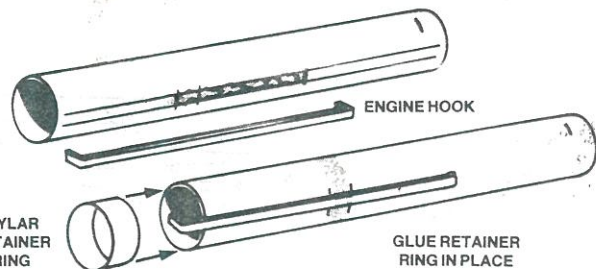

21 Apply a line of glue to the engine mount tube between the double lines from the 1" (25 mm) to the 2 1/2" (64 mm) mark. Insert one end of an engine hook into the slit on the double lines and lay it flat against the glue between the lines. Apply a line of glue around the tube between the 1" (25 mm) and 1 5/16" (33 mm) marks. Slide a mylar retainer ring over the tube and hook until it is centered on the glue between the marks.

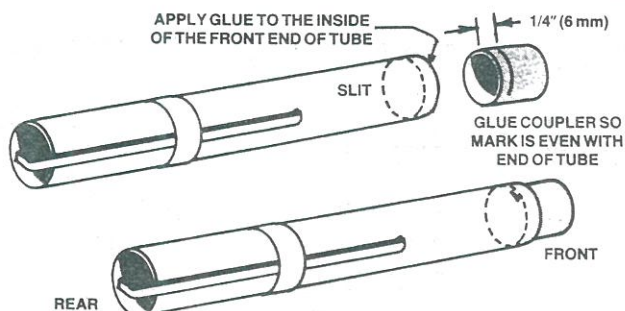

22 Mark the small tube coupler 1/4" (6 mm) from one end. Apply a line of glue around the inside of the front end of the engine tube. Insert the marked end of the tube coupler so 1/4" (6 mm) is glued inside the tube and 1/2" (13 mm) projects from the tube.

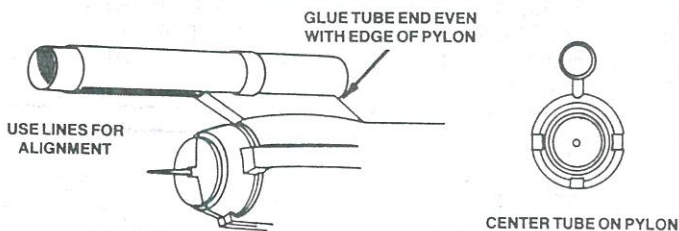

23 Using the group of four parallel lines on the engine mount tube as a guide, glue the tube to the hull pylon. The tube must point straight ahead. Sight down the rear of the tube to be sure the center line of the pylon is aimed at the center line of the tube.

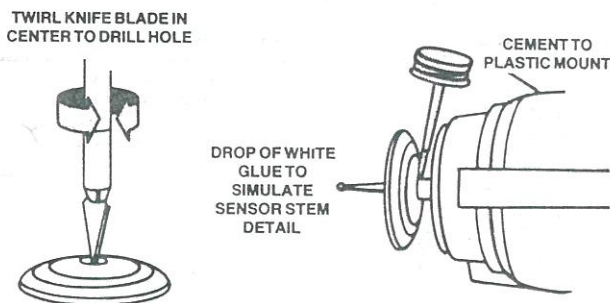

24 Drill a hole in the center of the sensor dish. The hole should be just large enough to fit on the dowel projecting from the secondary hull. Use plastic cement to glue the dish in place on the dowel against the projecting mount on the hull.

APPLY GLUE IN NOTCH

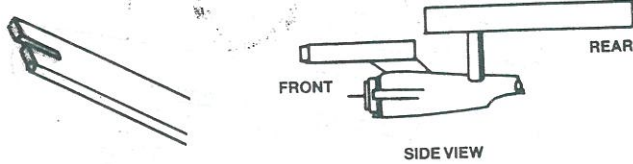

- 25** Check the fit of the engine support pylons in the cutouts in the secondary hull. Enlarge the holes if necessary. Apply glue to the inside surface of the notch in each engine support pylon. Insert the pylons into the secondary hull until they seat fully in the corresponding notches in the bulkhead. Make sure the left tube is on the left as you look at the model from the rear.

TAIL CAP → ← 1/4" (6 mm)

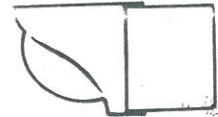
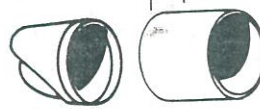

CROSS SECTION VIEW

- 29** Check the fit of the tube couplers inside the tail caps. If necessary, sand the tail caps until the tube joiners fit 1/4" (6 mm) into the tail caps. Use slow-setting instant glue to join tail caps and tube joiners.

CUT 1/8" (3 mm) DOWEL TO LENGTH, GLUE TO INTERCOOLER CARD PIECE

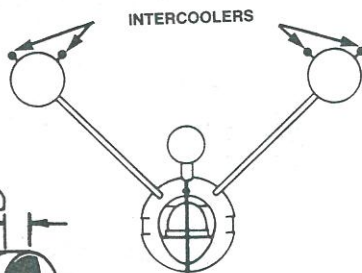

REAR VIEW

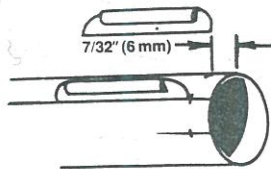

- 26** Carefully remove the intercooler pieces from the die-cut sheet. Set aside one of the large dowels to use later in constructing the recovery probe. Cut four pieces of the remaining large dowel to fit into the intercoolers exactly. Glue the dowel to the card pieces. Glue the intercoolers to the two upper lines on each propulsion unit tube with the rear of each intercooler on the mark, 7/32" (6 mm) from the rear of the tube.

CEMENT TAIL CAPS TO PROPULSION UNITS



- 30** Test fit the tail cap assemblies in the tubes. Remove and smear yellow carpenter's glue around the inside of the rear of the propulsion unit tubes, and insert the tail assemblies.

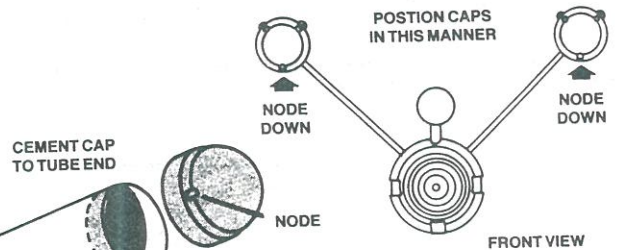

FRONT VIEW

- 31** Check the fit of the dome caps on the fronts of the propulsion unit tubes. Smear tube-type plastic cement around the front 3/16" (5 mm) of the outside of each propulsion unit tube. Let dry. Apply tube-type plastic cement to the mating surface on the inside of the dome caps and install them so one of the small nodes points straight down on each.

→ ← 7/32" (6 mm)

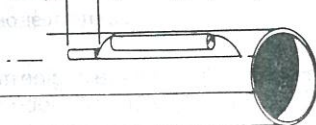

GLUE 7/32" (6 mm) LENGTH OF 1/12" (2 mm) DOWEL IN FRONT OF INTERCOOLER

- 27** Cut four 7/32" (6 mm) long pieces of the 1/12" (2 mm) diameter dowel and glue one on the line in front of each intercooler.

COVER TOP OF ENGINE TUBE WITH SLOW-SETTING INSTANT GLUE

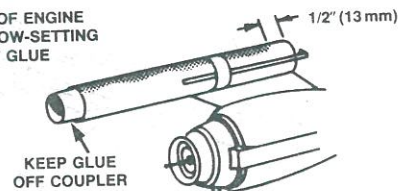

CENTER LARGE RECTANGLE ON SIDELINES

RECTANGLE ON EACH SIDE OF EACH UNIT

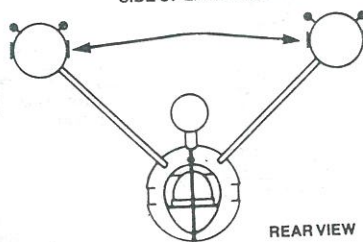
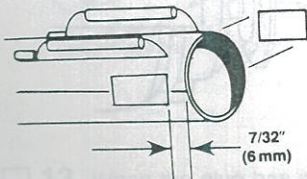

REAR VIEW

- 28** Remove four of the large rectangles from the die-cut card sheet. Glue one on each side of the propulsion unit tubes, centered on the side lines. The rear of each piece should be on the mark, 7/32" (6 mm) from the rear of the tube.

- 32** Apply a thin, smooth coat of slow-setting instant glue to the top of the engine mount tube, starting 1/2" (13 mm) from the rear and extending all the way forward over an area 3/16" (5 mm) to each side of the single line. Do not get any glue on the tube coupler. Join the primary hull to engine mount, being careful to align the hull so it is perfectly flat on the model (see drawing on next page). Make sure the retaining ring is centered in its recess. Hold in position, pressing firmly in place, for two or three minutes until the glue starts to set. Avoid putting any strain on the joint for at least two hours.

32 Continued

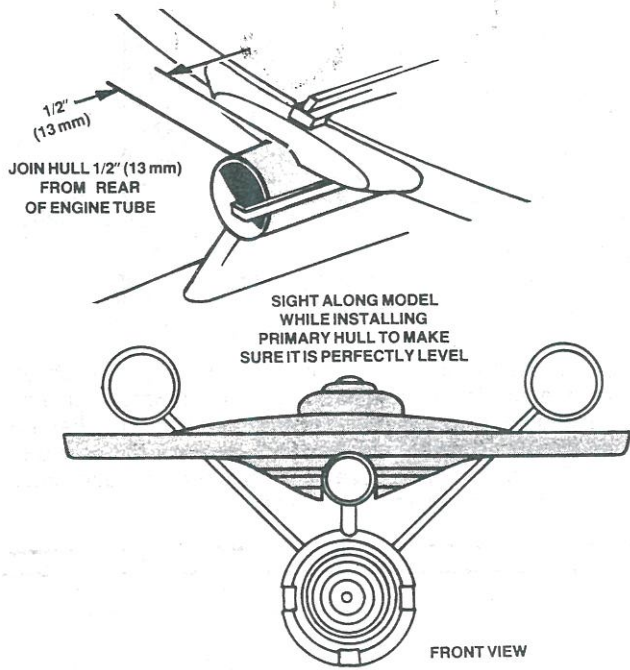

STABILITY PROBE ASSEMBLY

MARK AT EACH ARROW POINT AND EXTEND LINES

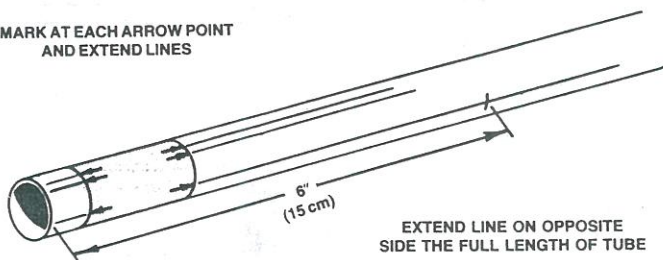

33 Cut out the probe body marking guide from the pattern sheet. Wrap it around the long probe body tube near one end. Mark at each arrow point. Draw straight lines connecting each matching front and rear mark. Extend the single line closest to the double line to 6" (15.2 cm) from the end of the tube. Extend the line on the side opposite the double line for the entire length of the tube.

MEASURE WITH ENGINE HOOK

MARK AND SLIT HERE

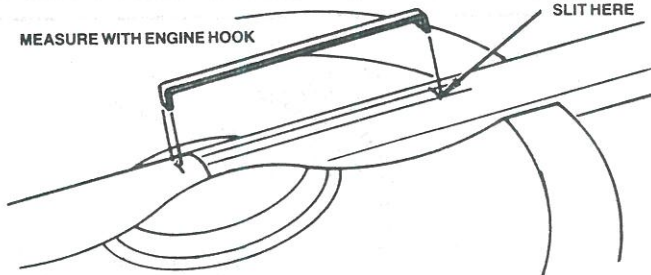

34 Temporarily slide the probe body onto the tube coupler on the engine mount. Position it so the double lines are aligned with the forward slit in the engine mount. Insert one end of the remaining engine hook in the slit and mark the probe body between the lines at the other end of the hook. Cut a 1/8" (3 mm) slit at the mark and seat the hook ends in both slits to check the fit. Remove hook and probe tube.

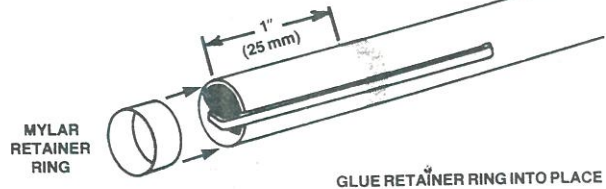
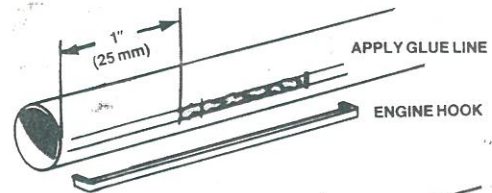

35 Apply a drop of glue to the slit in the probe tube and a line of glue between the double lines from the slit to 1" (25 mm) from the tube end. Insert the end of the hook into the slit, pressing the shaft of the hook into the glue and centering it between the lines. Apply a line of glue around the tube and over the hook 1" (25 mm) from the end of the tube and slide the remaining retainer ring over hook and tube onto the glue. The end of the ring should be 1" (25 mm) from the end of the tube.

GLUE HOLD-DOWN STAND-OFF 4 1/8" FROM REAR OF TUBE

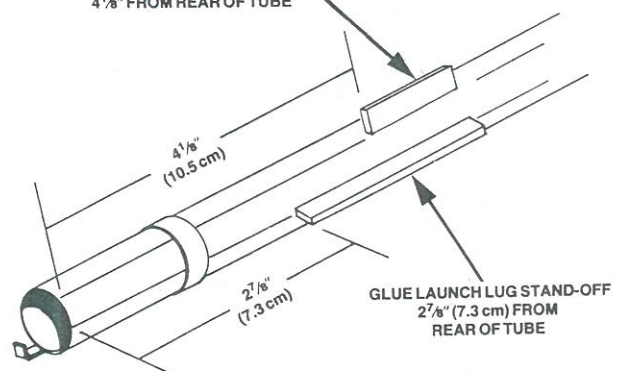

36 Mark the short line 2 7/8" (73 mm) from the rear of the probe body. Mark the long line 4 1/8" (105 mm) from the rear. Carefully separate the launch lug stand-off and the hold-down stand-off from the die-cut plywood sheet. Glue the launch lug stand-off (the longer piece) to the short line with its rear on the mark. Glue the hold-down stand-off to the long line with its rear on the mark, 4 1/8" (105 mm) from the rear of the tube.

GLUE 1/8" (3 mm) x 1 1/2" (38 mm) LONG DOWEL TO STAND-OFF

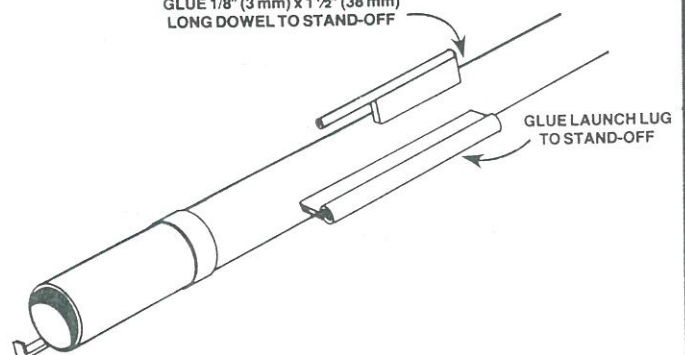

37 From the 1/8" (34 mm) diameter dowel, cut a piece 1 1/2" (38 mm) long. Glue the dowel to the hold-down stand-off so the front of the dowel is even with the front of the stand-off as shown. Glue the launch lug to the launch lug stand-off.

CUT AND GLUE A 1 1/8" (28.9 cm)
LONG, 1/8" (3 mm) DIAMETER
DOWEL TO TUBE WITH END
AGAINST STAND-OFF

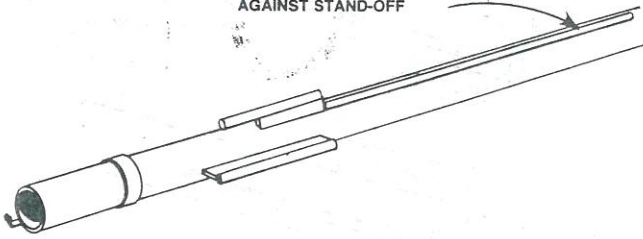

38 From the 1/8" (3 mm) diameter dowel, cut a piece 1 1/8" (28.9 cm) long. Glue the long dowel piece to the recovery probe body on the line with its end glue against the hold-down. Hold the dowel securely in place with masking tape until the glue dries.

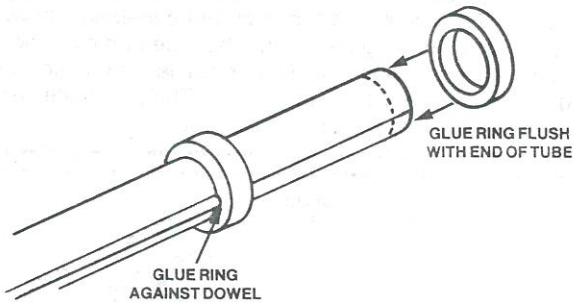

39 Check the fit of the adapter rings on the front of the probe body. Sand their inside surfaces if necessary for a smooth fit. Apply a line of glue around the tube at the front, 3/8" (10 mm) ahead of the end of the dowel. Slide a ring onto the tube, onto the glue, and back against the dowel. Glue the other ring to the tube so the front edges of ring and tube are even. Allow glue to dry.

SMEAR GLUE 1" (25 mm) INSIDE TUBE
AND SLIDE ADAPTER RINGS INTO
END FLUSH WITH END OF TUBE

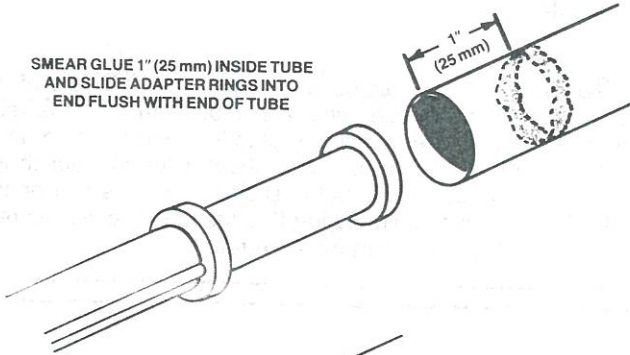

RUB EXTRA GLUE
INTO JOINT OF RING
AND TUBE

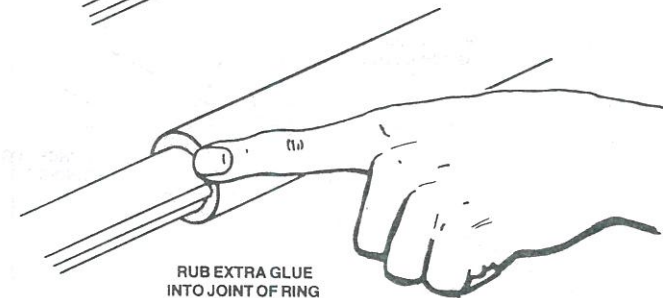

40 Smear glue around the inside of the parachute compartment tube approximately 1" (25 mm) from one end. Slide this end onto the adapter rings on the probe body until the rear of the 'chute tube is even with the back of the rear ring. Rub glue onto the joint between the 'chute tube and the ring at the back.

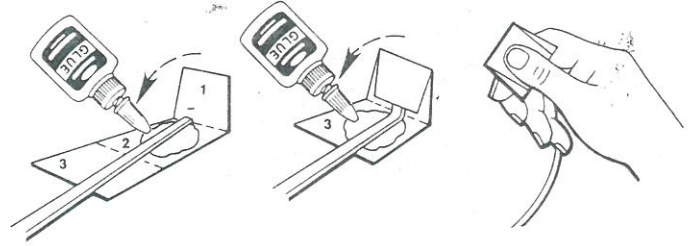

41 Cut out the shock cord mount from the pattern sheet. Crease the mount on the dotted lines by folding. Spread glue on section 2 and lay one end of the shock cord into the glue at a slight diagonal as shown. Fold section 1 forward. Fold section 3 forward. Fold forward again. Clamp the shock cord mount firmly between your fingers until the glue sets.

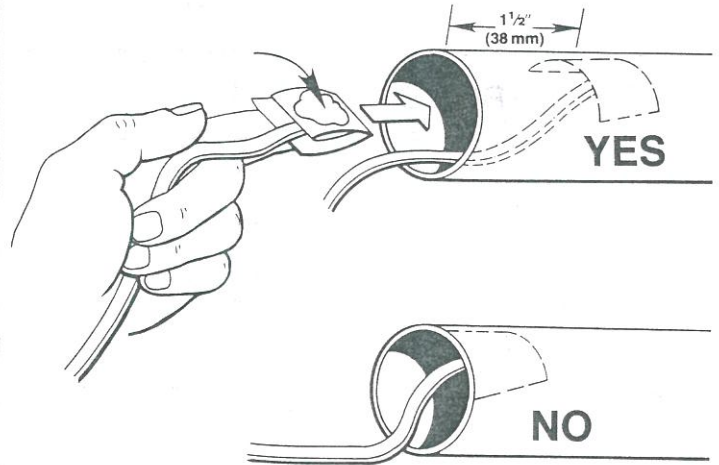

42 Apply glue to back side of the complete shock cord mount. Push the shock cord mount against the inside of the upper stage body tube about 1 1/2" (38 mm) from the forward edge. Make sure all of the mount curves and contacts the tube wall before the glue sets. More glue may be added and rubbed into the shock cord mount for an even stronger bond if desired.

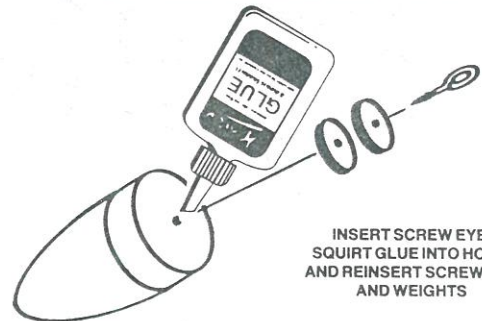

INSERT SCREW EYE,
SQUIRT GLUE INTO HOLE,
AND REINSERT SCREW EYE
AND WEIGHTS

43 Insert the screw eye into the base of the nose cone. Remove screw eye and squirt glue into the hole. Install the two nose cone weights on the screw eye and re-insert the screw eye into the hole in the nose cone.

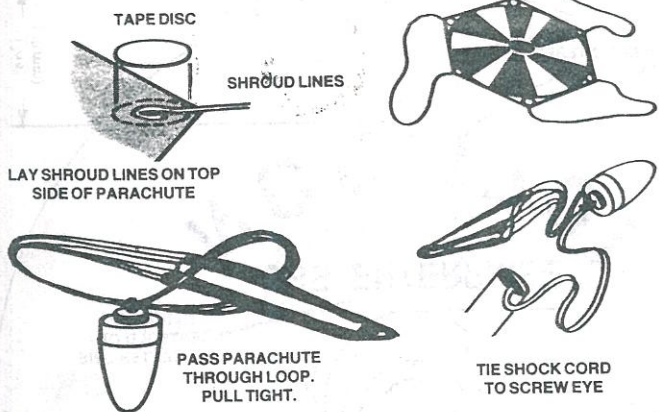

44 Cut out the parachute on its edge lines. Cut three 36" (91.4 cm) lengths of shroud line. Attach line ends to top of parachute with tape discs as shown. Pass shroud line loops through screw eye. Pass parachute through loop ends and draw lines tight against screw eye. Set knot with a drop of glue. Tie free end of shock cord to screw eye.

45 Sand all exposed wood surfaces lightly with extra fine sandpaper. Apply at least two coats of sanding sealer, sanding lightly between coats. When the pores in the wood are filled and the surfaces look and feel smooth, install the recovery probe on the model and use it as a handle while you give the starship itself a clean, white base coat of spray enamel. When the base coat is dry, apply an overall final color coat of "Camouflage Gray". Let the paint on the model dry at least overnight before continuing. (Use the stability probe both to support the model while painting and to protect the tube coupler from being painted. The paint job on the probe itself can be completed later.)

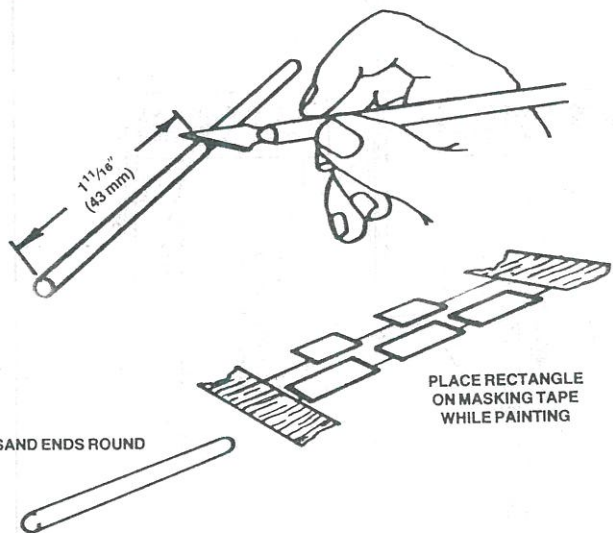

46 Cut two 1 1/16" (43 mm) long pieces from the 1/8" (3 mm) diameter dowel. Round the end of these pieces slightly with fine sandpaper. Give these pieces a camouflage gray, paint one side and the edges of the two small rectangles and the six large rectangles from the die-cut card.

47 Apply trim paint colors as shown in the decor illustration. If using spray paint, use masking tape to outline the area to be painted. Protect the rest of the model from overspray (a plastic bag taped over the model makes an excellent cover.)

DIP DECAL IN WATER FOR ABOUT TEN SECONDS



HOLD DECAL UNTIL IT UNCURLS, THEN SLIDE IT OFF BACKING PAPER INTO POSITION



48 Apply the decals as shown in the decor illustration. To apply water-transfer decals, cut out an individual section of the decal and dip in lukewarm water for ten seconds. Hold the decal until it uncurls, then gently slide it off the backing sheet onto the model in the correct position. Blot away excess water. Dry overnight and apply a coat of clear spray to protect the decals.

WRAP TRIM GUIDE AROUND FRONT OF PROPULSION UNIT WITH LARGE ARROW POINTING TO BOTTOM NODE. MARK AT EACH SMALL ARROW POINT.

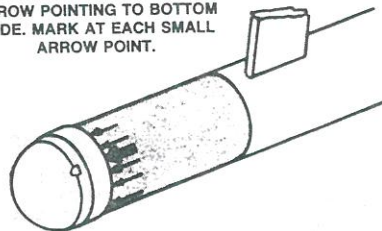

GLUE WITH SLOW-SETTING INSTANT GLUE THREE GRAY-PAINTED RECTANGLES IN PLACE

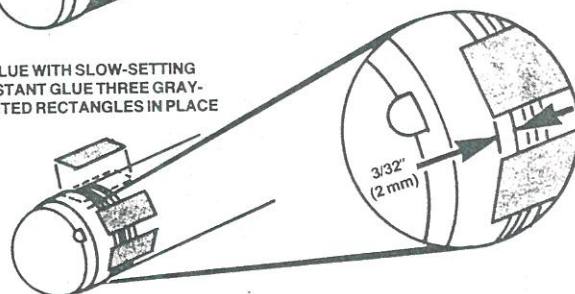

49 Cut out the trim positioning guide from the pattern sheet. Place it against a propulsion unit dome cap and mark at each of the small arrows. Mark the other cap in the same way. Use slow-setting instant glue to attach the six large, gray-painted rectangles from the die-cut card to the propulsion units. The pieces should be centered between marks and extend 3/32" (2 mm) onto the dome.

SCRAPE DECAL AWAY FROM INSIDE OF THE SMALL CIRCLE

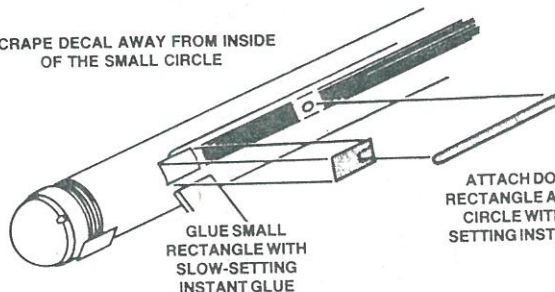

50 Use slow-setting instant glue to attach one of the small, gray-painted rectangles to the inner side of each propulsion unit directly over the rectangle outline on the decal. Glue one of the dowels prepared in step 46 to each propulsion unit; carefully scrape through the decal in the small circle on the decal, then attach each dowel to the circle at one end and the rectangle at the other as shown.

TOP VIEW

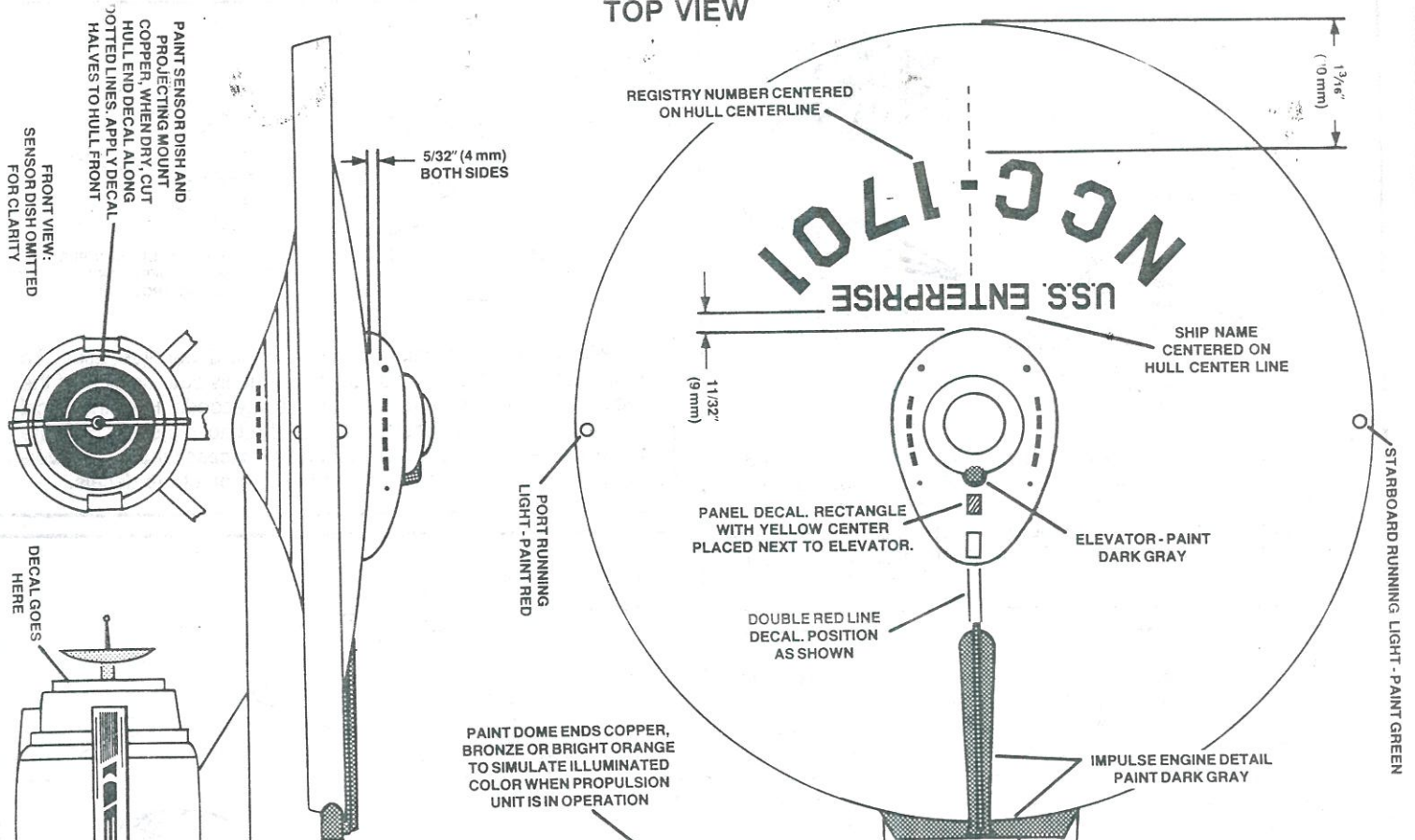

PORT (LEFT) SIDE VIEW

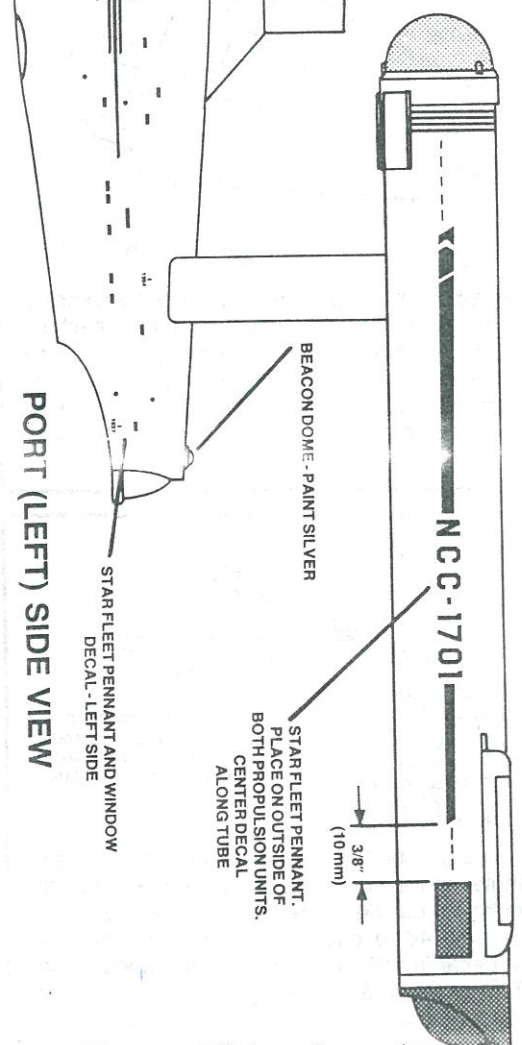

DECOR ILLUSTRATION

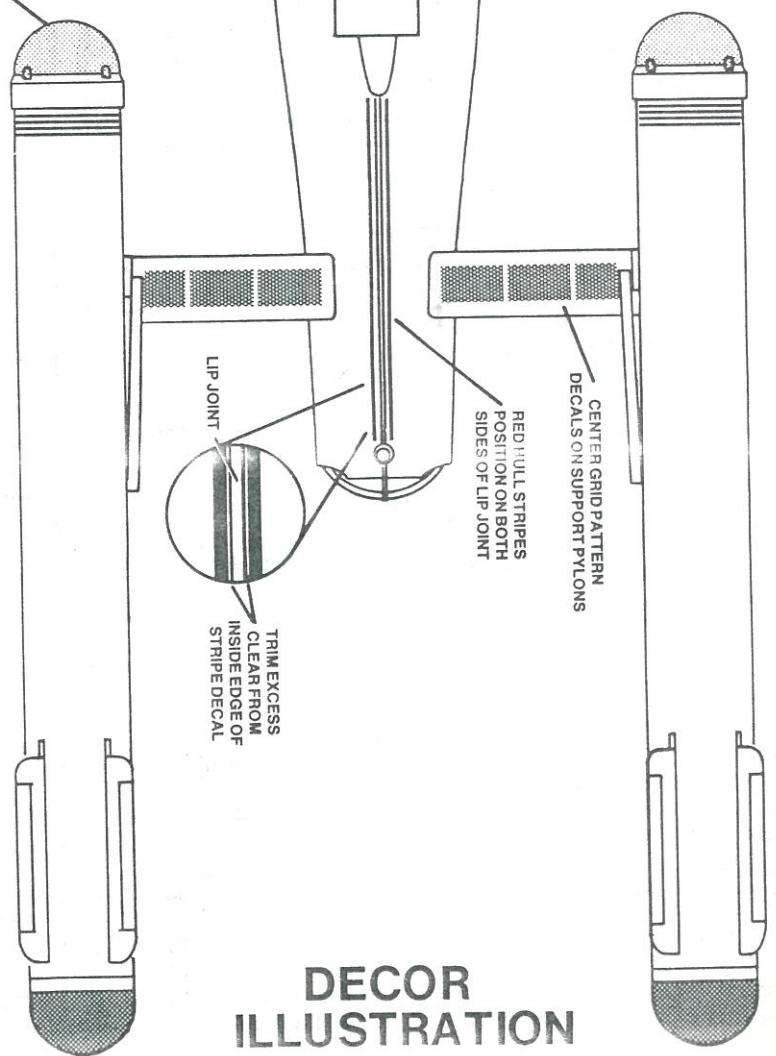

BOTTOM VIEW

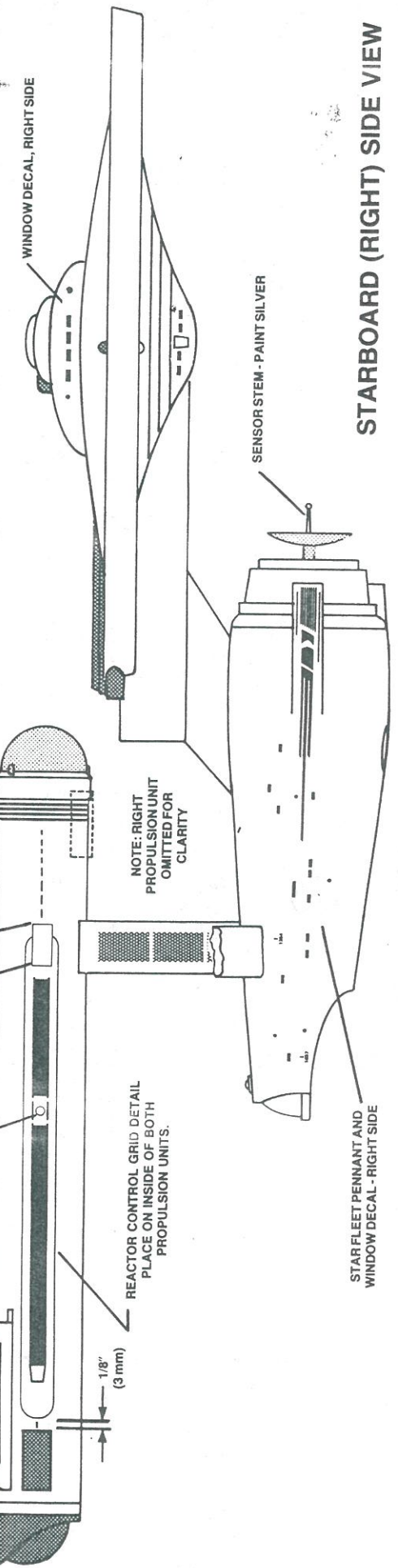
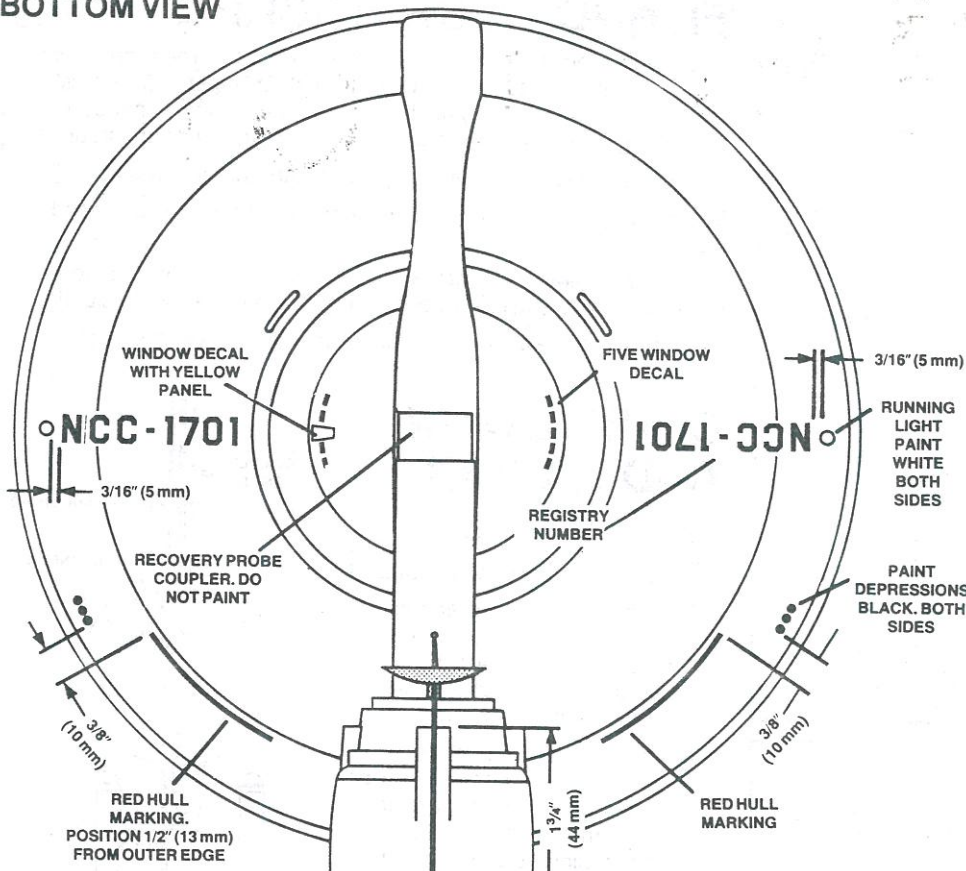

STARBOARD (RIGHT) SIDE VIEW

USS ENTERPRISE DECOR SCHEME

The following Pactra or Testor's spray and brush-on enamel paints are recommended to duplicate the authentic Star Fleet service colors:

COLOR CODING

- LIGHT GRAY (Camouflage Gray) — Overall ship color and recovery probe
- DARK GRAY (REBEL GRAY)
- COPPER OR BRONZE

Other colors you will need as noted in decor scheme illustrations: Red, Green, White, Black, and Silver.

NOTE: Butyrate dope paints should not be used on plastic surfaces because they will produce a crinkled finish when dry.

TRIM EXCESS CLEAR FROM ONE SIDE OF LINE DECAL. START DECAL AT BOTTOM. POSITION IMMEDIATELY NEXT TO CAP.

ROCKET PREFLIGHT

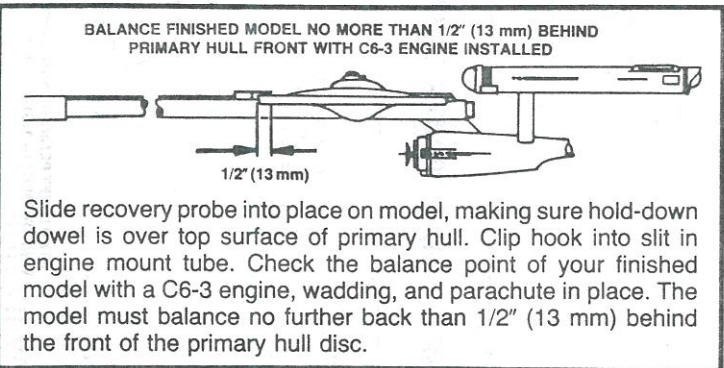
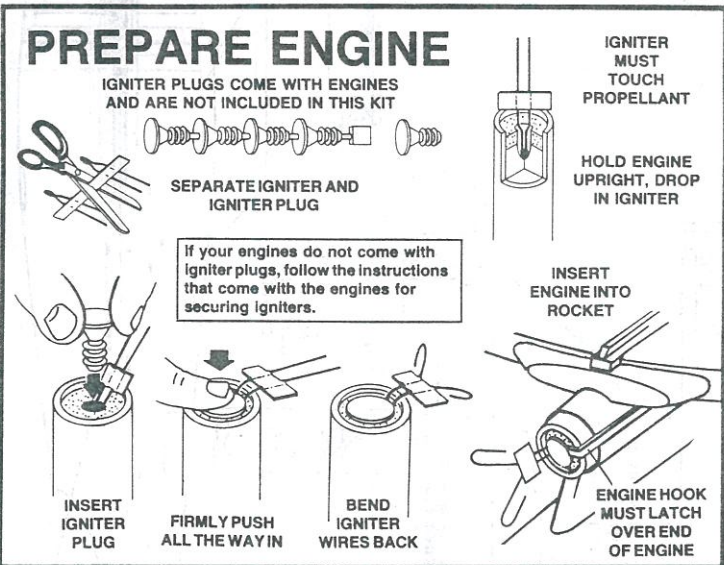
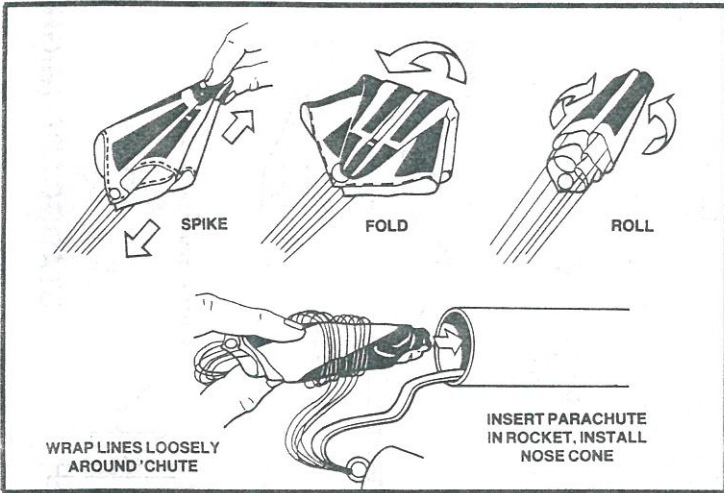
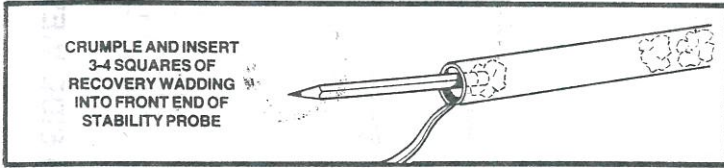

LAUNCH SUPPLIES

To launch your rocket you will need the following items:

- An Estes Launch System and Launch Pad with 1/8" (3 mm) diameter launch rod
- Estes Recovery Wadding No. 2274
- Recommended Estes Engines: B6-2 or C6-3

To become familiar with your rocket's flight pattern, use a B6-2 engine for your first flight.

Use only Estes products to launch this rocket.

FLYING YOUR ROCKET

Choose a large field away from power lines, tall trees, and low flying aircraft. Try to find a field at least 250 feet (76 meters) square. The larger the launch area, the better your chance of recovering your rocket. Football fields and playgrounds are great.

Launch area must be free of dry weeds and brown grass.

Launch only during calm weather with little or no wind and good visibility.

Don't leave parachute packed more than a minute or so before launch during cold weather [colder than 40° Fahrenheit (4° Celsius)].

Parachute may be dusted with talcum powder to avoid sticking.

COUNTDOWN AND LAUNCH

- BE CERTAIN SAFETY KEY IS NOT IN LAUNCH CONTROLLER.
- Remove safety cap and slide launch lug over launch rod to place rocket on launch pad. Make sure the rocket slides freely on the launch rod.
- Attach micro-clips to the igniter wires. Arrange the clips so they do not touch each other or the metal blast deflector. Attach clips as close to protective tape on igniter as possible. A suggested method is to tape the leads to the launch rod after attaching the clips, strating just below the clips.
- Move back from your rocket as far as launch wire will permit (at least 15 feet - 5 meters).
- INSERT SAFETY KEY to arm the launch controller.

Give audible countdown 5...4...3...2...1

LAUNCH!! PUSH AND HOLD LAUNCH BUTTON UNTIL ENGINE IGNITES

REMOVE SAFETY KEY FROM LAUNCH CONTROLLER. REPLACE SAFETY KEY AND SAFETY CAP ON LAUNCH ROD.

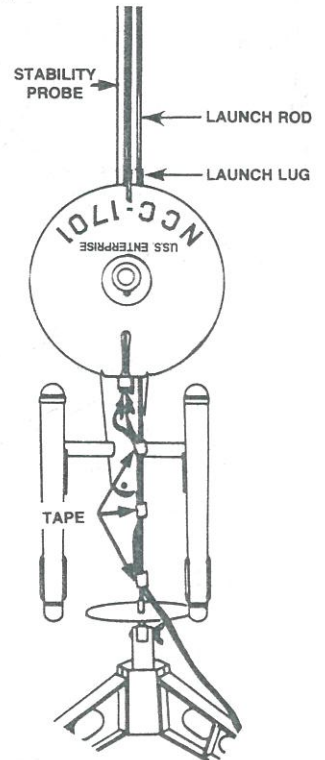

MISFIRES

When an ignition failure occurs, remove the safety key from the launch control system and wait one minute before approaching the rocket. Remove the expended igniter from the engine and install a new one. Be certain the coated tip is in direct contact with the engine propellant, then press the igniter plug into nozzle of engine as illustrated above. Repeat the countdown and launch procedure.

FOR YOUR SAFETY AND ENJOYMENT

Always follow the NAR* MODEL ROCKETRY SAFETY CODE while participating in any model rocketry activities.

*National Association of Rocketry