

ICARUS

KIT NO. 1277

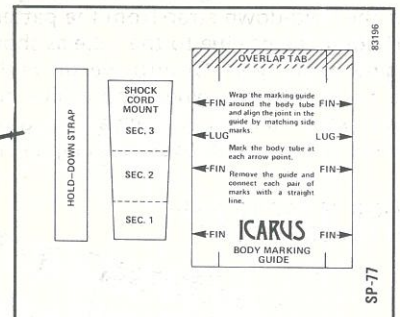
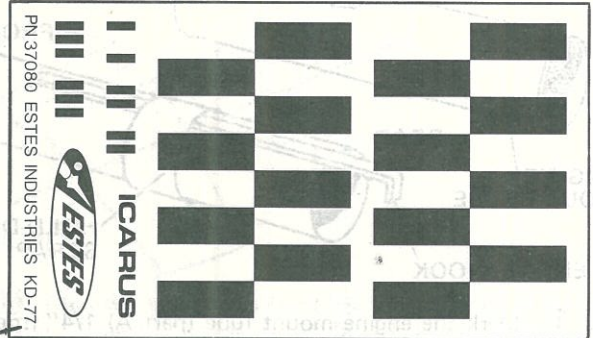
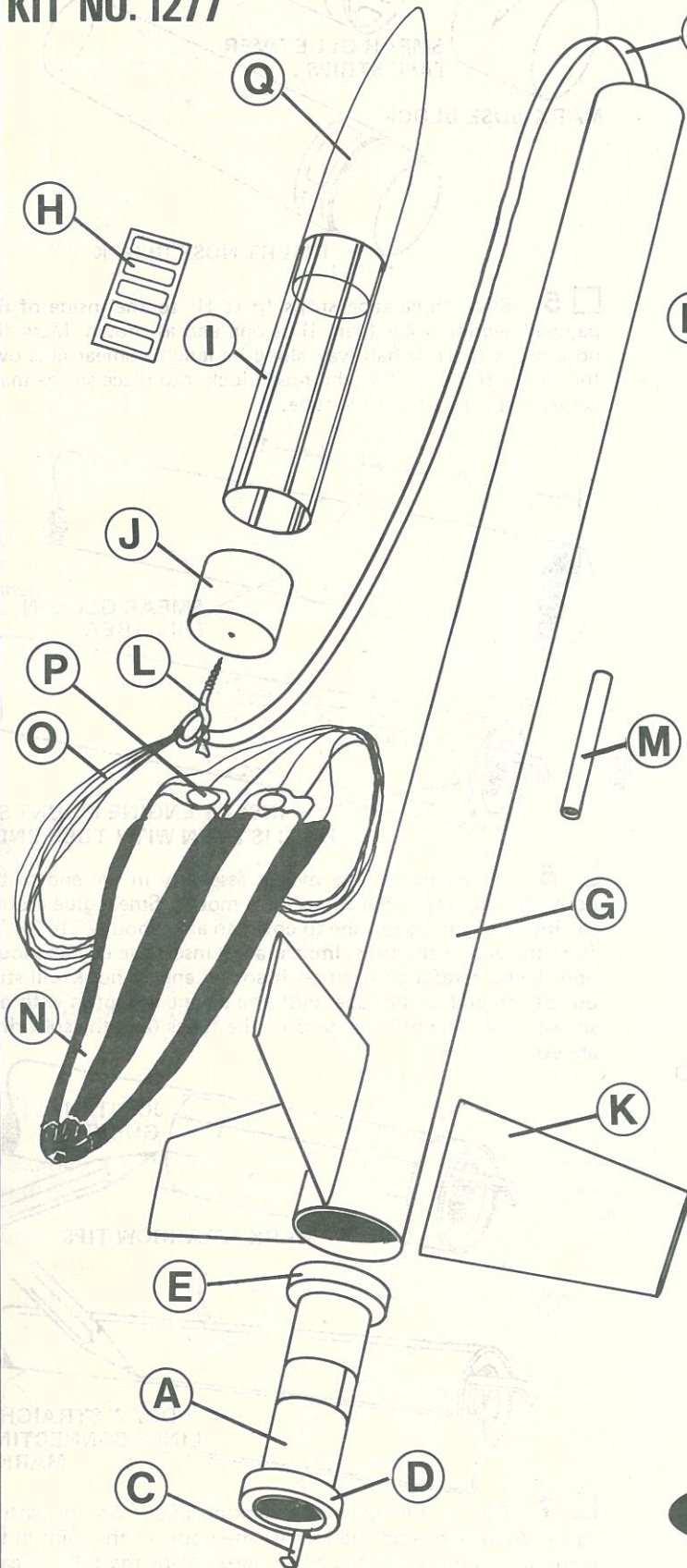

PARTS LIST

	PART NO.
A) 1 Engine Mount Tube (type BT-20J)	30326
B) 1 Pattern Sheet (type SP-77)	83196
C) 1 Engine Hook (type EH-2)	35025
D) 1 Split Adapter Ring (type AR-2050S)	80425
E) 1 Adapter Ring (type AR-2050)	30164
F) 1 Shock Cord (type SC-1)	85730
G) 1 Body Tube (type BT-50L)	30366
H) 5 Tape Strips (type TD-2E)	38505
I) 1 Payload Section Tube (type PST-50S)	30608
J) 1 Nose Block (type NB-50)	70158
K) 1 Balsa Fin Sheet (type BF-77)	32241
L) 1 Screw Eye (type SE-2A)	38252
M) 1 Launch Lug (type LL-2B)	38178
N) 1 Parachute (type PK-12A)	85564
O) 1 72" Shroud Line Cord (type SLT-72)	38237
P) 6 Tape Discs (type TD-3F)	38406
Q) 1 Nose Cone (type PNC-50Y)	71009
R) 1 Decal (type KD-77)	37080

In addition to the parts included in this kit you will need scissors, white glue, a sharp model knife (or single edge razor blade), sandpaper, sanding sealer, and paint.

IMPORTANT:

Read all instructions before beginning work on your model. Make sure you have all parts and materials. When you are thoroughly familiar with the assembly procedure, begin construction. Check off each step as you complete it. In each step, test-fit the parts together before applying any glue. If some part doesn't fit properly, sand lightly or build up as appropriate for precision assembly.



A SUBSIDIARY OF DAMON

ESTES INDUSTRIES
PENROSE, COLO. 81240

ASSEMBLY INSTRUCTIONS

TO REINFORCE,
APPLY 1" GLUE
LINE HERE

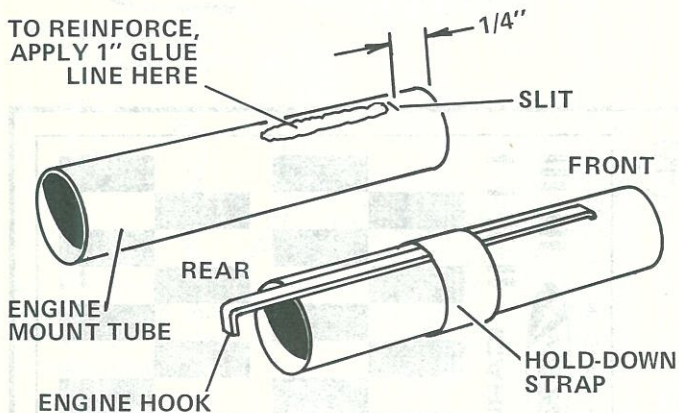

1 Mark the engine mount tube (part A) 1/4" from one end. Cut a 1/8" long slit in the tube at the mark as shown. Cut out the hold-down strap from the pattern sheet (part B). Apply a 1" long line of glue to the tube as shown. Push one end of the engine hook (part C) into the slit and press the main part of the hook into the glue. Apply glue to one side of the hold-down strap and wrap it, glue side down, tightly around the middle of the tube over the engine hook.

HOOK MUST BE FREE
TO RAISE IN SLOT

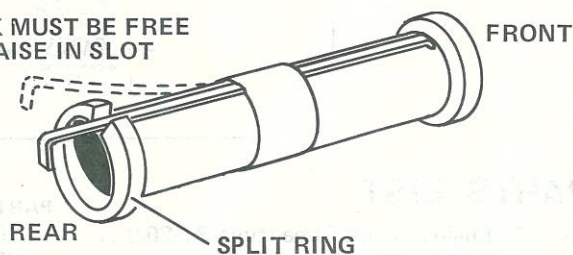

2 Glue the split adapter ring (part D) to the engine mount tube even with the rear end (the end with the overhanging hook) so the slot is over the hook. Avoid getting glue in the slot. Glue the other ring (part E) to the front of the engine mount against the end of the hook as shown.

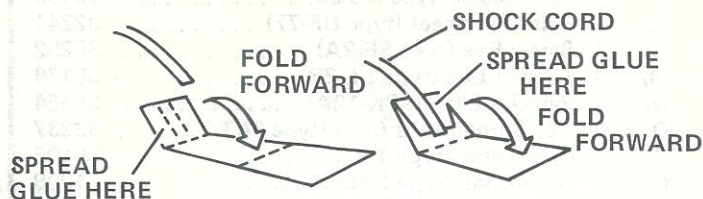

3 Cut out the shock cord mount from the pattern sheet. Crease it on the dotted lines by folding. Spread glue on the first section (1) and lay the end of the shock cord (part F) into the glue. Fold over and apply glue to the back of the first section and the exposed part of section 2. Clamp the unit together with your fingers until the glue sets.

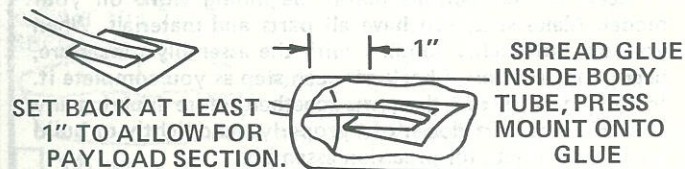

4 Apply glue to the inside of the body tube (part G) at one end over an area about 1" to 2" from the end. The glued area should be the same size as the shock cord mount. Press the mount into the glue as shown and hold it until the glue sets.

APPLY TAPE
STRIPS JUST
INSIDE TUBE

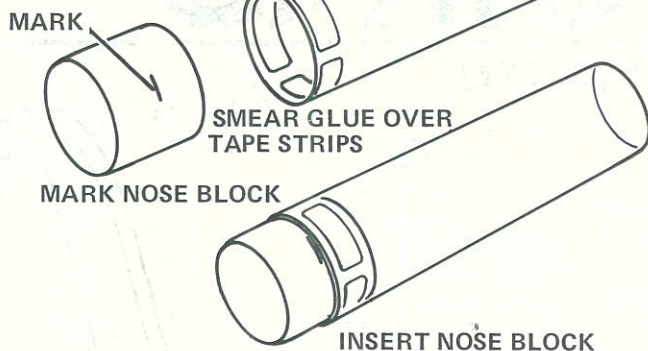

5 Stick three tape strips (part H) to the inside of the payload section tube (part I) at one end as shown. Mark the nose block (part J) half-way along its length. Smear glue over the tape strips and slide the nose block into place so the mark is even with the end of the tube.

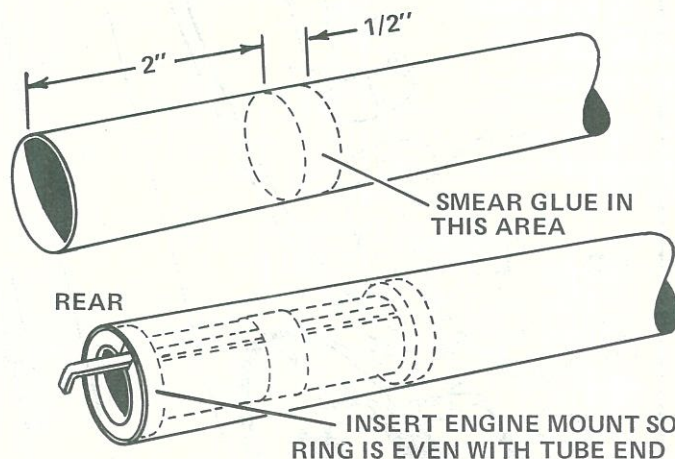

6 Install the engine mount assembly in the end of the body tube opposite the shock cord mount. Smear glue around the inside of the body tube to cover an area about 2" to 2-1/2" from the end of the tube. Immediately insert the engine mount unit, being careful to position it so the engine hook will stick out of the end of the tube. Push the engine mount in with one smooth motion until the ends of the tubes (and the split ring) are even.

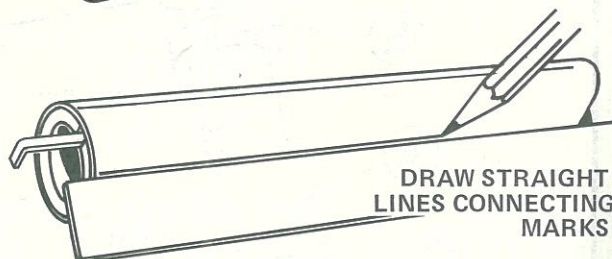
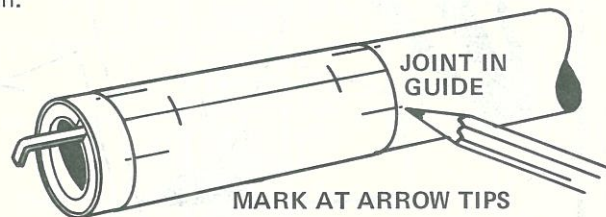

7 Cut out the body tube marking guide from the pattern sheet. Wrap it around the rear of the body so the joint in the guide is in line with the engine hook. Mark the tube at each arrow point, front and rear. Draw a straight line connecting

each matching front and rear mark (use a ruler when drawing lines). Extend the launch lug line forward 7".

FINE SAND BALSA SHEET AND REMOVE DIE-CUT FIN

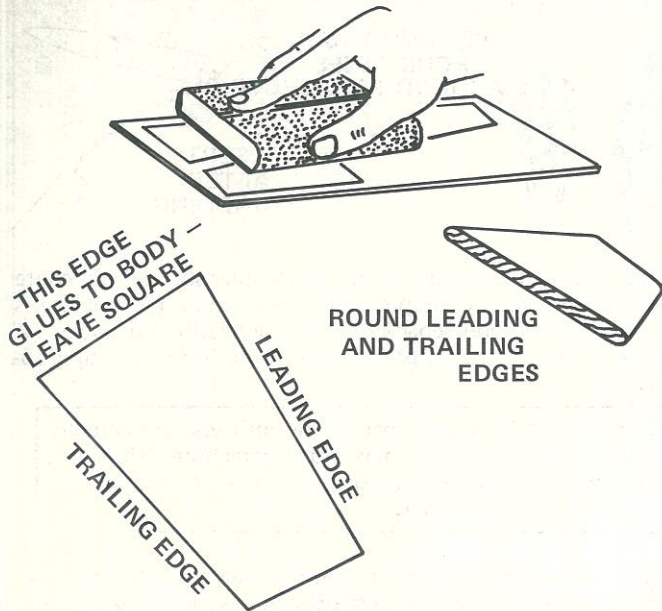

8 Fine-sand the balsa sheet (part K), then carefully remove the die-cut fins from the sheet. Free the edges with a sharp knife. Sand the leading and trailing edges of the fins round. Leave the other edges square.

RUB A LINE OF GLUE INTO ROOT EDGE OF EACH FIN

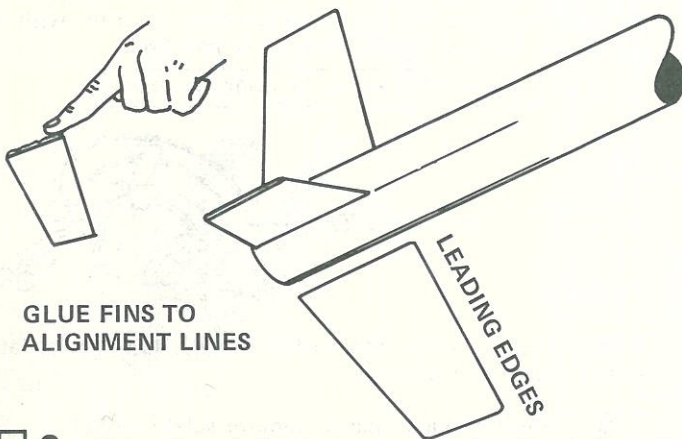

9 Rub a line of glue into the root edge of each fin and allow to dry. Glue the fins to the body on the alignment lines drawn in step 7. Refer to the illustration to be sure you position the fins correctly. Adjust the fins so they project straight away from the body tube. Do not set the rocket on its fins while the glue is wet.

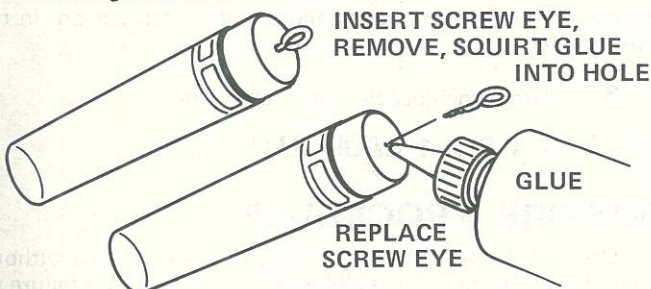

10 Insert the screw eye (part L) into the base of the nose block. Remove the screw eye and squirt a small amount of glue into the hole. Re-insert the screw eye.

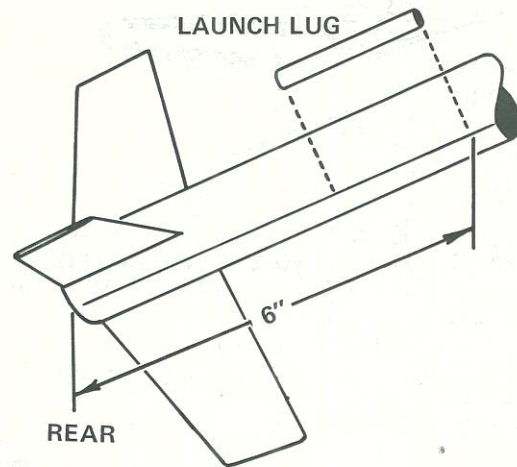

11 Glue the launch lug (part M) to the body on its line. The front of the lug should be 6" from the rear of the body. Align it straight on the body.

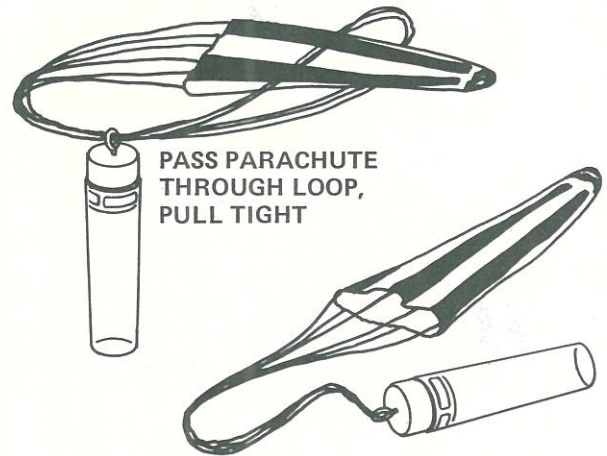

12 Cut out the parachute (part N) on its edge lines. Cut three 24" lengths of shroud line (part O). Attach line ends to the top of the parachute with tape discs (part P) as shown. Pass the shroud line loops through the screw eye. Pass the parachute through the loop ends and draw lines tight against the screw eye. Set knot with a drop of glue.



13 Apply a glue "fillet" to each fin joint. Holding the rocket horizontally (level), apply a line of glue to both sides of each joint. Smooth out the glue with your finger. Keep the rocket level until the glue dries.

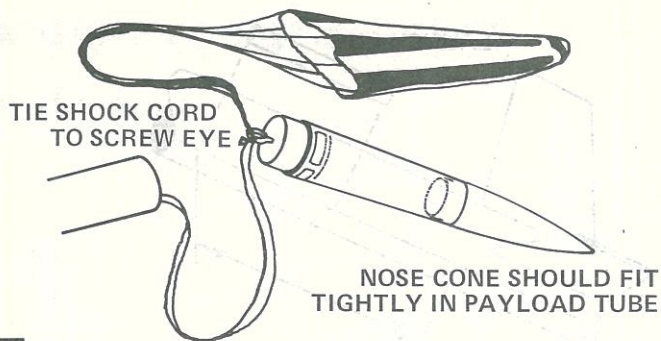

□ 14 Tie the free end of the shock cord to the screw eye. Insert the nose cone (part Q) in the front of the payload section tube. If the nose cone is loose, wrap tape on its base until it makes a tight fit.

WHITE — OVERALL ROCKET
BLACK — BANDS ON PAYLOAD SECTION AND NOSE CONE



□ 15 When all glue on the outside of the body is dry, prepare the fins for painting. Apply at least two coats of sanding sealer to the fins. Let dry and sand lightly between coats. Do this until the tiny holes in the wood are filled and everything looks and feels smooth. Paint the body and fins white. Paint the nose cone and the nose block area of the payload tube black.

DIP DECAL IN WATER FOR ABOUT 10 SECONDS

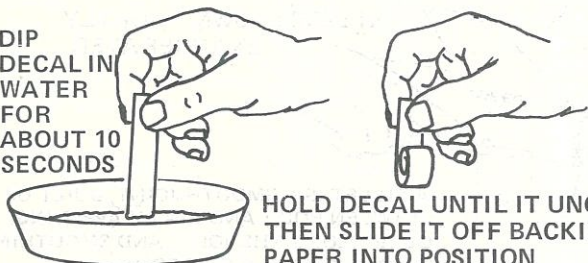

□ 16 When all paint is dry, apply decals (part R). Cut out a decal section, dip it in lukewarm water for 10 seconds, and hold it until it uncurls. Slip the decal off the backing sheet and onto the model. Blot excess water away. For best results, let the model dry overnight and apply a coat of clear spray to protect the decals.

COUNTDOWN CHECKLIST

Be sure to follow the HIAA - NAR Model Rocketry Safety Code when carrying out all your model rocketry activities.

T-14 Pack four squares of loosely crumpled recovery wadding into body tube.

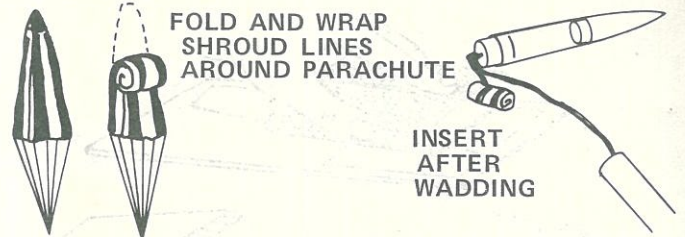

T-13 Fold the parachute into a triangular shape. Roll 'chute tightly as shown and wrap shroud lines around it. If 'chute is too large, unroll and repack until it slides easily into rocket. A fit that is too tight may prevent parachute from ejecting properly.

NOTE: DO NOT pack parachute until you are actually ready to launch. For maximum parachute reliability, lightly dust 'chute with ordinary talcum powder, especially in cold weather.

T-12 Pack shock cord neatly into rocket, then slide payload section into place. Payload section should separate easily from rocket body tube, but should not be extremely loose. If it is too tight, sand inside of body tube and shoulder of nose block with extra fine sandpaper.

If payload section is too loose, add a wrapping of transparent tape or masking tape to the shoulder of the nose block.

T-11 Select an engine and install an igniter as directed in the engine instructions. Engines recommended for use with this rocket are 1/2A6-2, A8-3, B4-4, B6-4, and C6-5.

Use an A8-3 engine for your first flight.

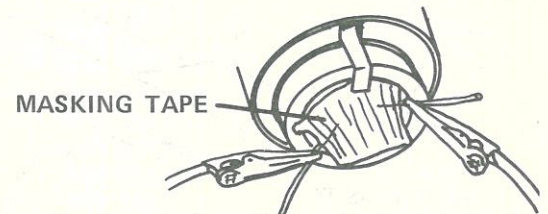

T-10 Insert engine into rocket. Engine hook must latch securely over end of engine.

T-9 Disarm launch panel--remove safety key.

T-8 Place rocket on launch pad making sure rocket slides freely on launch rod. Clean micro-clips and attach them to igniter leads.

T-7 Clear the launch area, alert recovery crew and trackers. Check for low flying aircraft and unauthorized persons in recovery area.

T-6 Arm launch panel--insert safety key.

5 4 3 2 1 LAUNCH!!

MISFIRE PROCEDURE

Occasionally an igniter will heat and burn in two without igniting the engine. This is almost always caused by a failure to install it correctly. Disarm launch panel, remove the model, clean igniter residue from nozzle and install a new igniter. Follow launching procedure again.