

# Vigilante

KIT NO. 1278

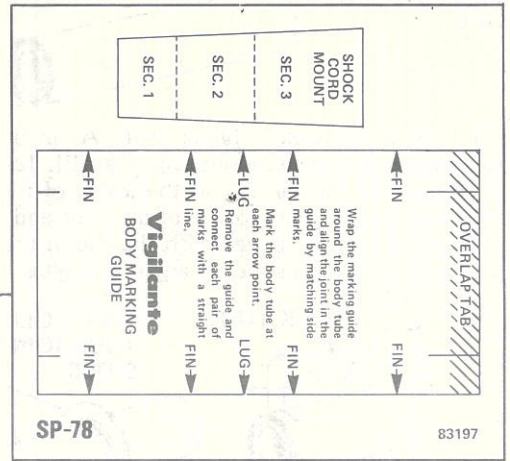
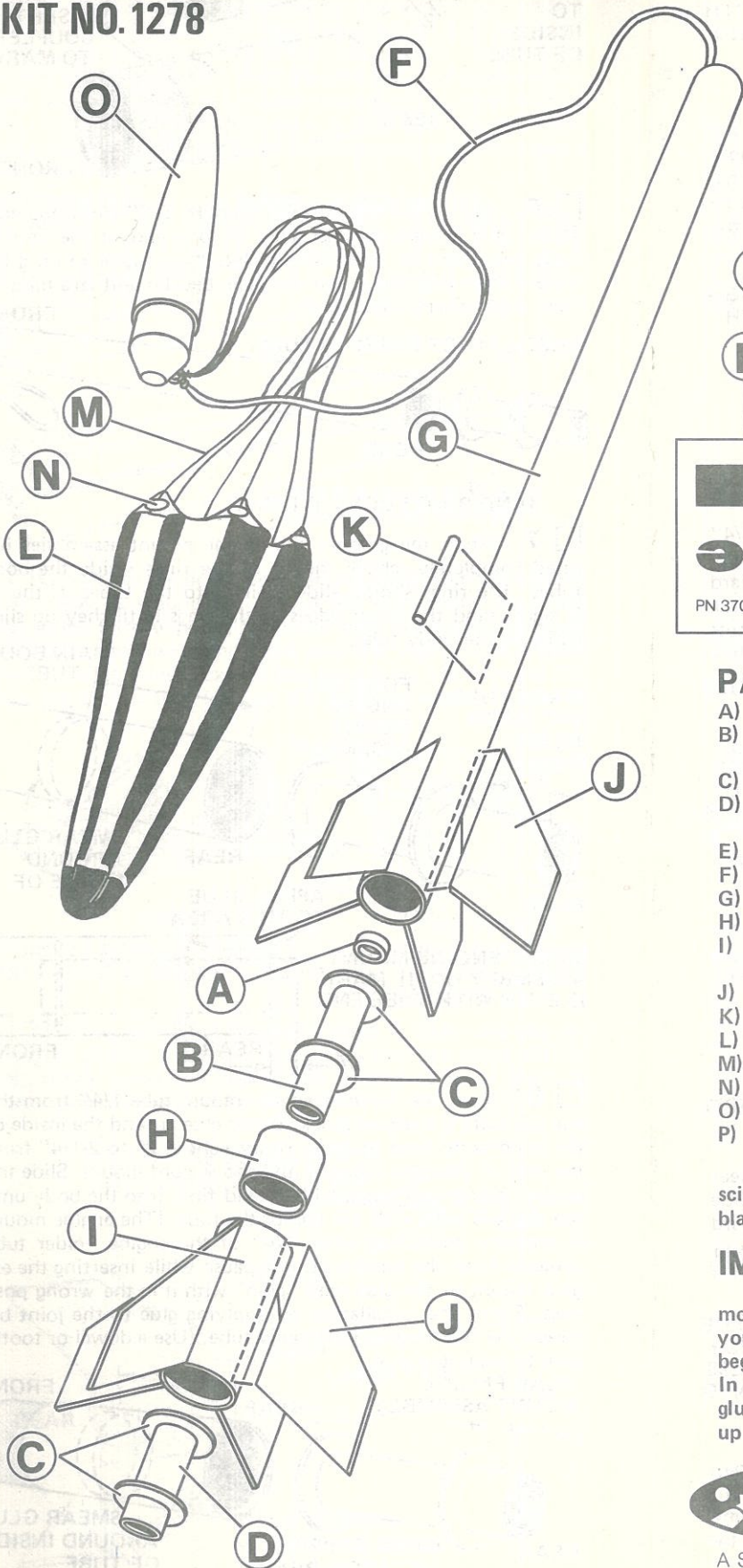

**Vigilante**  
**Vigilante**

PN 37081    ESTES INDUSTRIES    PENROSE, COLORADO    KD-78

## PARTS LIST

	PART NO.
A) 1	Engine Block (type AR-520) ..... 30162
B) 1	Forward Engine Mount Tube (type BT-20J, 2.75") ..... 30326
C) 4	Adapter Rings (type RA-2055) ..... 30126
D) 1	Rear Engine Mount Tube (type BT-20M, 2.25") ..... 30334
E) 1	Pattern Sheet (type SP-78) ..... 83197
F) 1	Shock Cord (type SC-1) ..... 85730
G) 1	Main Body Tube (type BT-55, 18") ... 30382
H) 1	Stage Coupler (type JT-55C) ..... 30262
I) 1	Booster Body Tube (type BT-55J, 2.75") ..... 30386
J) 2	Balsa Fin Sheets (type BF-78) ..... 32239
K) 1	Launch Lug (type LL-2B) ..... 38178
L) 1	Parachute (type PK-18A) ..... 85566
M) 1	108" Shroud Line Cord (type SLT-108) 38239
N) 6	Tape Discs (type TD-3F) ..... 38406
O) 1	Plastic Nose Cone (type PNC-55AO) .. 71075
P) 1	Decal (type KD-78) ..... 37081

In addition to the parts included in this kit you will need scissors, white glue, a sharp model knife (or single edge razor blade), a pencil, a ruler, sandpaper, sanding sealer, and paint.

## IMPORTANT:

Read all instructions before beginning work on your model. Make sure you have all parts and materials. When you are thoroughly familiar with the assembly procedure, begin construction. Check off each step as you complete it. In each step, test-fit the parts together before applying any glue. If some part doesn't fit properly, sand lightly or build up as appropriate for precision assembly.



A SUBSIDIARY OF DAMON

**ESTES INDUSTRIES**  
PENROSE, COLO. 81240



# ASSEMBLY INSTRUCTIONS

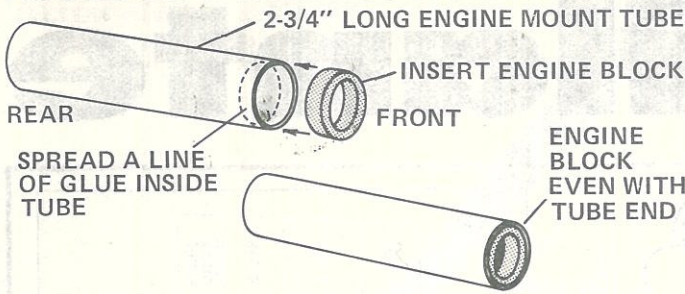

**1** Glue the engine block (part A) in one end of the longer (forward) engine mount tube (part B). To do this, apply glue around the last  $\frac{3}{16}$ " on the inside of the tube. Immediately slide the engine block into the same end of the tube so the end of the block is even with the end of the tube. Let the unit sit a minute, then wipe off any excess glue.

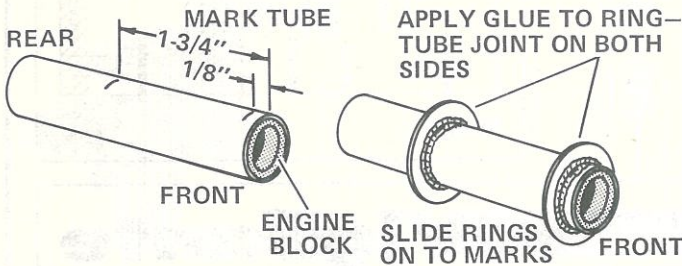

**2** Mark the forward engine mount tube  $\frac{1}{8}$ " and  $1\text{-}\frac{3}{4}$ " from the front (the end with the engine block). Carefully separate two of the adapter rings (part C) from the die-cut card sheets. Slide the rings onto the tube so one is at each mark. Glue the rings in place by applying a line of glue where ring meets tube—all around on both sides. Set the assembly on end while the glue dries.

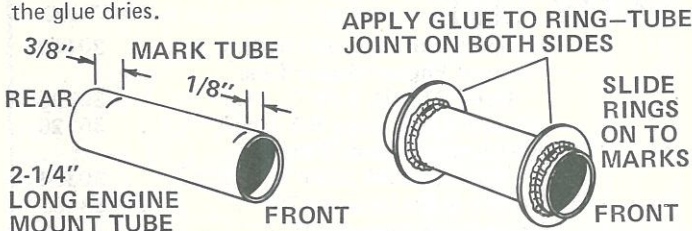

**3** Mark the shorter (rear) engine mount tube (part D)  $\frac{1}{8}$ " from one end and  $\frac{3}{8}$ " from the other. Glue an adapter ring to the tube at each mark. (Use the same gluing technique as in step 2.) Set the assembly on end while the glue dries.



**4** Cut out the shock cord mount from the pattern sheet (part E). Crease it on the dotted lines by folding. Spread glue on the first section (1) and lay the end of the shock cord (part F) into the glue. Fold over and apply glue to the back of the first section and the exposed part of section 2. Clamp the unit together with your fingers until the glue sets.

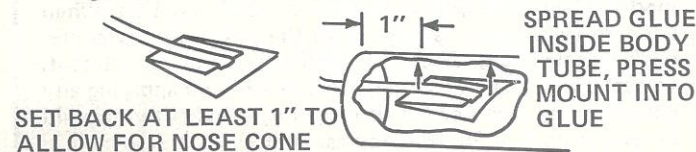

**5** Apply glue to the inside of the main body tube (part G) at one end over an area about 1" to 2" from the end. The glued area should be the same size as the shock cord mount. Press the mount into the glue as shown and hold it until the glue sets.

## BOOSTER BODY

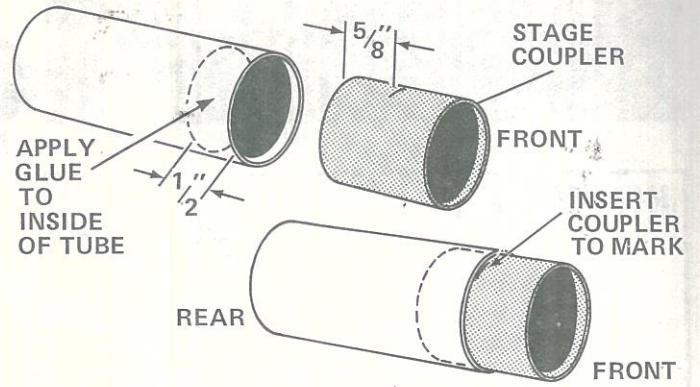

**6** Mark the stage coupler (part H)  $\frac{5}{8}$ " from one end. Apply glue around the last  $\frac{1}{2}$ " in one end of the booster body tube (part I). Immediately slide the coupler in until the mark is even with the end of the tube. Let the unit set a minute, then wipe off any excess glue.

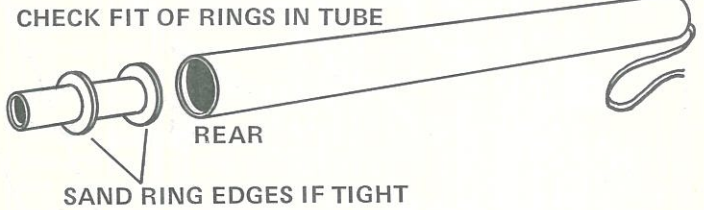

**7** When the glue on the engine mount assemblies has dried completely, check the fit of the rings inside the body tubes. The rings should slide easily into the tubes. If the fit is tight, sand the outer edges of the rings until they do slide easily in the body tube.

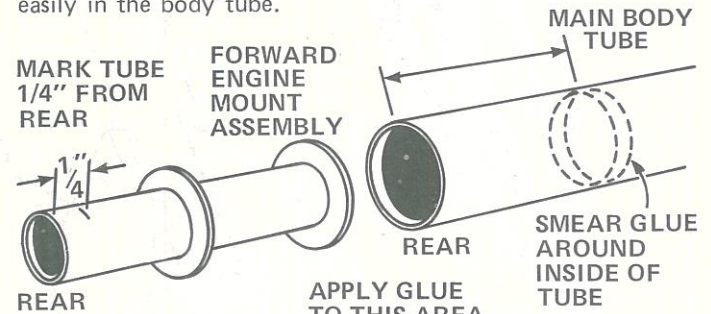

**8** Mark the forward engine mount tube  $\frac{1}{4}$ " from the end opposite the engine block. Smear glue around the inside of the main body tube to cover an area about 2" to  $2\text{-}\frac{1}{4}$ " from the end of the tube opposite the shock cord mount. Slide the engine mount unit, engine block end first, into the body until the mark is even with the end of the tube. (The engine mount is properly positioned when  $\frac{1}{4}$ " of the engine holder tube projects from the body.) Do not pause while inserting the engine mount or the glue may "grab" with it in the wrong position. Finish the installation by applying glue to the joint between the rear ring and the body tube. (Use a dowel or toothpick to apply the glue.)

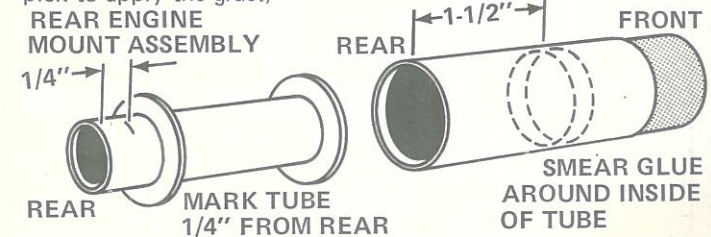



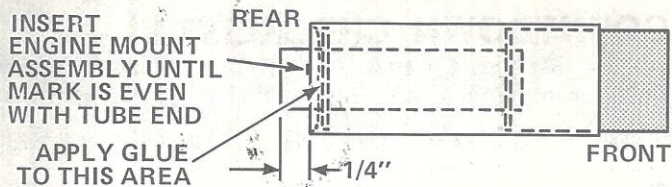

9 Mark the rear engine mount tube 1/4" from the rear (the end with the greatest space between tube end and ring). Smear glue around the inside of the booster body tube to cover an area 1-1/2" to 1-3/4" from the rear (the end opposite the stage coupler). Slide the engine mount unit, unmarked end first, into the body until the mark is even with the tube end. Apply a line of glue around the joint between the rear ring and the body tube.

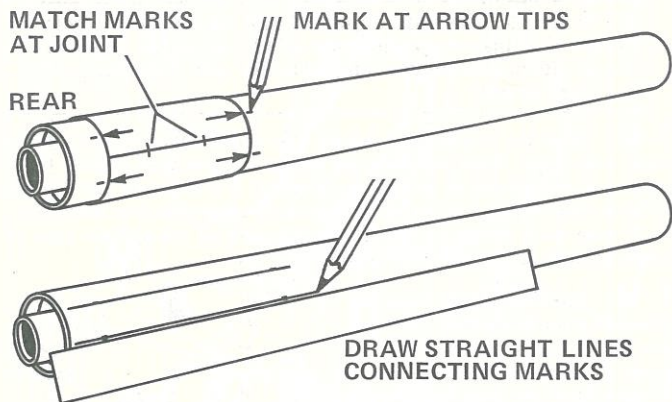

10 Cut out the body tube marking guide from the pattern sheet. Wrap it around the rear of the main body. Mark the tube at each arrow point, front and rear. Draw a straight line connecting each matching front and rear mark. (Use a ruler when drawing lines.) Extend the launch lug line forward 7". Mark the booster tube for four fins in the same way.

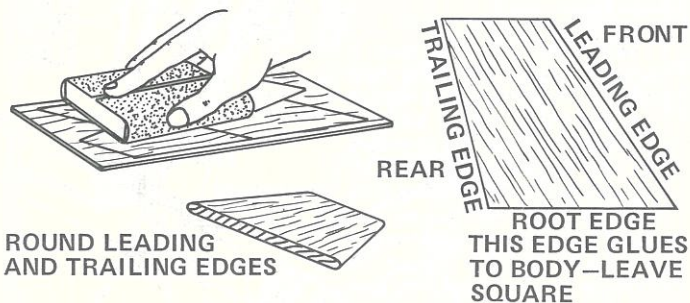

11 Fine sand the balsa sheets (part J), then carefully remove the die-cut fins from the sheet. Free the edges with a sharp knife. Sand the leading and trailing edges of the fins round. Leave the other edges square.

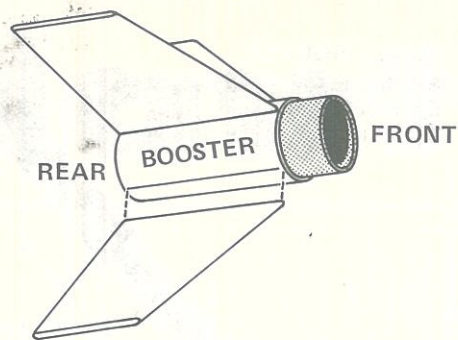
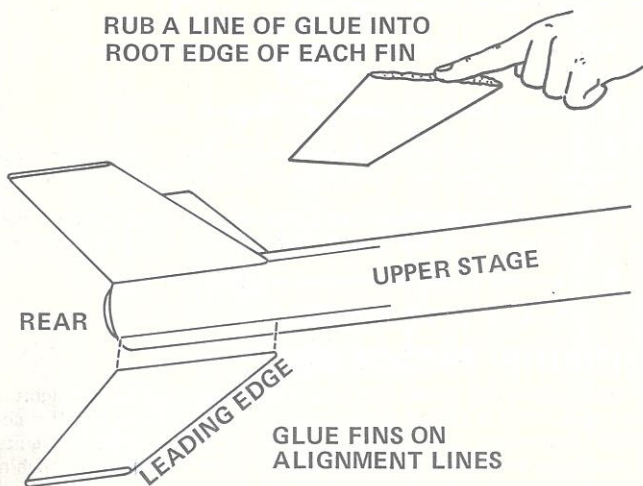

12 Rub a line of glue into the root edge of each fin and allow to dry. Glue the fins to the main body and the booster body on the fin alignment lines drawn in step 10. Refer to the illustration to be sure you position the fins correctly. The rear edge of each fin should be even with the rear edge of the body tube. Adjust the fins so they project straight away from the body tube. Do not set the rocket on its fins while the glue is wet.

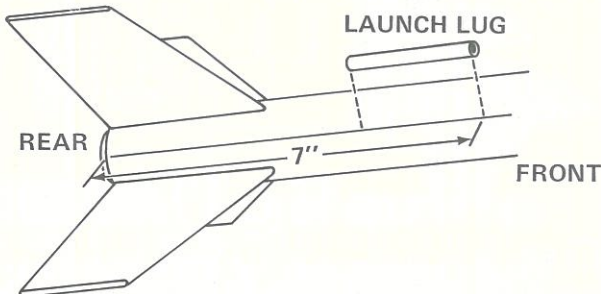

13 Glue the launch lug (part K) to the main body on its line. The front of the lug should be 7" from the rear of the body. Align it straight on the body.

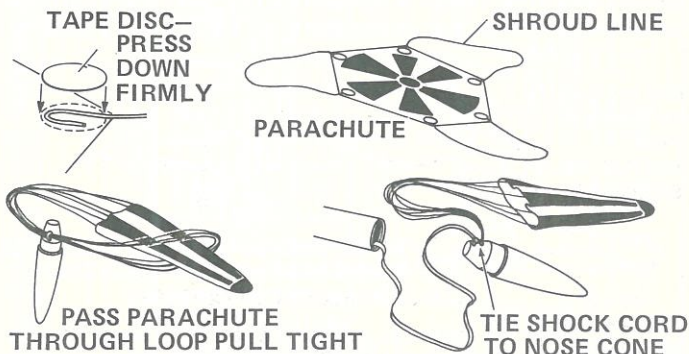

14 Cut out the parachute (part L) on its edge lines. Cut three 36" lengths of shroud line (part M). Attach line ends to the top of the parachute with tape discs (part N) as shown. Pass the shroud line loops through the ring on the nose cone (part O). Pass the parachute through the loop ends and draw the lines tight against the ring. Set knot with a drop of glue. Tie the free end of the shock cord to the nose cone ring.

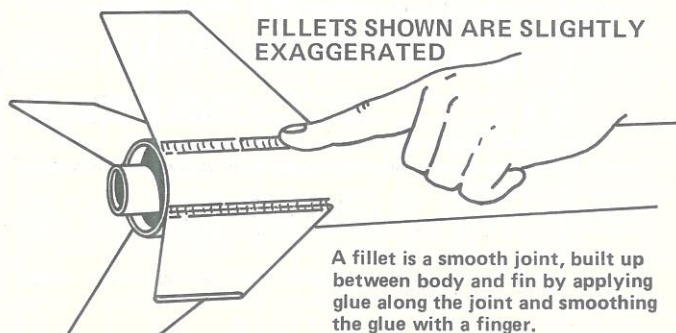

15 Apply a glue "fillet" to each fin joint. Holding the rocket horizontally (level), apply a line of glue to both sides of each joint. Smooth out the glue with your finger. Keep the rocket level until the glue dries.



**YELLOW—OVERALL ROCKET**  
**BLACK—NOSE CONE AND FRONT**  
**4" OF BODY TUBE**

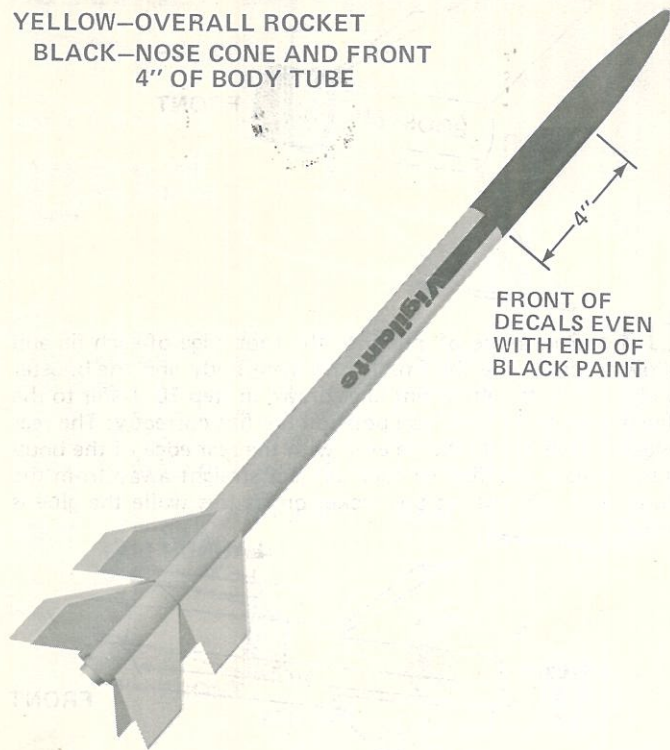

FRONT OF  
DECALS EVEN  
WITH END OF  
BLACK PAINT

**16** When all glue on the outside of the body is dry, prepare the model for painting. Apply at least two coats of sanding sealer to all wood parts. Let dry and sand lightly between coats. Do this until the tiny holes in the wood are filled and everything looks and feels smooth. Paint the entire rocket yellow. When the yellow is completely dry, paint the nose cone and front 4" of the main body black.

DIP DECAL  
IN WATER  
FOR  
ABOUT 10  
SECONDS

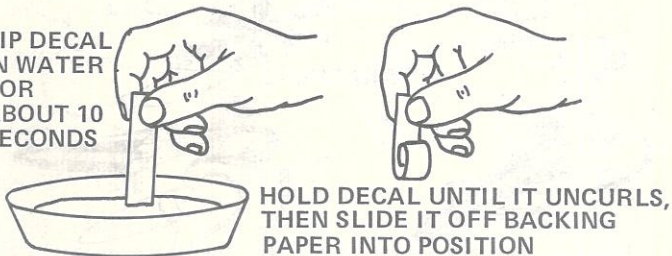

**17** When all paint is dry (allow at least overnight for drying), apply decals (part P). Cut out a decal section, dip it in lukewarm water for 10 seconds, and hold it until it uncurls. Slip the decal off the backing sheet and onto the model. Blot away excess water. For best results, let the model dry overnight and apply a coat of clear spray to protect the decals.

#### FLYING THE VIGILANTE

Your Vigilante model has been designed as a high performance two-stage sport model. The upper stage may also be flown by itself as a single stage sport or demonstration model. Here are some suggestions for getting the best results from your model:

- Obtain a copy of Estes Industries Technical Report TR-2 and study it before flying two-stage models.
- Always be extra careful when installing engines. Make sure they face the correct direction for proper staging. Make sure they are held tightly in place to insure proper recovery operation.
- Have an extra person with you when launching to watch the booster stage and retrieve it after flight.
- Launch in calm weather. The upper stage will drift a long way in a wind.
- When flying as a single stage model, make sure the engine is securely held in place.
- Always follow the Countdown Checklist when launching your model.

#### RECOMMENDED ENGINES

BOOSTER	UPPER STAGE
1/2A6-0, A8-0, B6-0, C6-0	1/2A6-4, A8-5, B4-6, B6-6, C6-7

Use an A8-0 and an A8-5 for the first multi-stage flight.

SINGLE STAGE LAUNCHES A8-3, B4-4, B6-4, B14-5, C6-5

Use an A8-3 engine for the first single stage flight.

## COUNTDOWN CHECKLIST

Be sure to follow the HIAA - NAR Model Rocketry Safety Code when carrying out all your model rocketry activities.

**T-17** Pack eight to ten squares of loosely crumpled recovery wadding into the body tube from the front.



**T-16** Fold the parachute into a triangular shape. Roll 'chute tightly as shown and wrap shroud lines around it. If 'chute is too large, unroll it and repack until it slides easily into rocket. A fit that is too tight may prevent parachute from ejecting properly.

**NOTE:** DO NOT pack parachute until you are actually ready to launch. For maximum parachute reliability, lightly dust the 'chute with ordinary talcum powder before each flight, especially in cold weather.

**T-15** Pack the shock cord neatly into rocket, then slide the nose cone into place. Nose cone should separate easily from rocket body tube, but should not be extremely loose. If it is too tight, sand inside of body tube end and shoulder of nose cone with extra fine sandpaper.

If nose cone is too loose, add a wrapping of transparent tape or masking tape to the shoulder of the nose cone.

**T-14** Select an upper stage engine and a booster engine. Remove any burrs from the ends of the engines by holding them against a smooth surface and turning as at right.

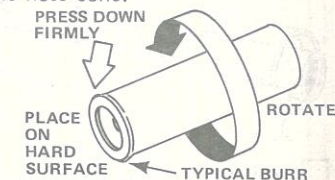

**T-13** Position the engines with the nozzle of the upper stage engine against the top end of the booster engine. Wrap a layer of cellophane tape tightly around the joint as shown at right. Check to be sure the engines are in their proper relative positions.

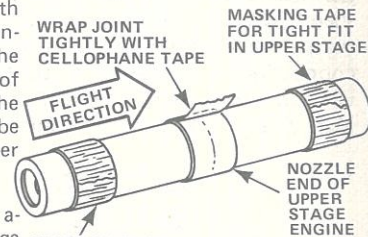

**T-12** Wrap masking tape around the top of the upper stage engine so it makes a tight friction fit in the engine mount tube. Insert the upper stage end of the engine unit into the upper stage engine mount. Finish securing it by wrapping a layer of masking tape around the end of the engine mount tube and the end of the engine as shown. Press the tape tight against the engine.

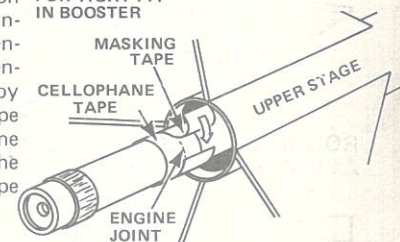

**T-11** Slide the booster into place on the engine unit from the bottom. Position it so the stage coupler fits all the way into the upper stage and the fins are in line. Secure the booster in place by wrapping a layer of masking tape around the end of the engine mount tube and the engine. Press the tape down tightly.

**T-10** Install an igniter in the booster engine as directed in the engine instructions.

**T-9** Disarm the launch panel--remove safety key.

**T-8** Place rocket on launch pad, making sure rocket slides freely on launch rod. Clean the micro-clips and attach them to the igniter.

**T-7** Clear the launch area, alert recovery crew and trackers. Check for low flying aircraft and unauthorized persons in the recovery area.

**T-6** Arm the launch panel--insert safety key.

**5 4 3 2 1 LAUNCH!!**

## MISFIRE PROCEDURE

Occasionally the igniter will heat and burn in two without igniting the engine. This is almost always caused by a failure to install it correctly. Disarm the launch panel, remove the model, clean the igniter residue from the nozzle, and install a new igniter. Follow the launching procedure again.