

PHOTON DISRUPTOR

KIT NO. 1282

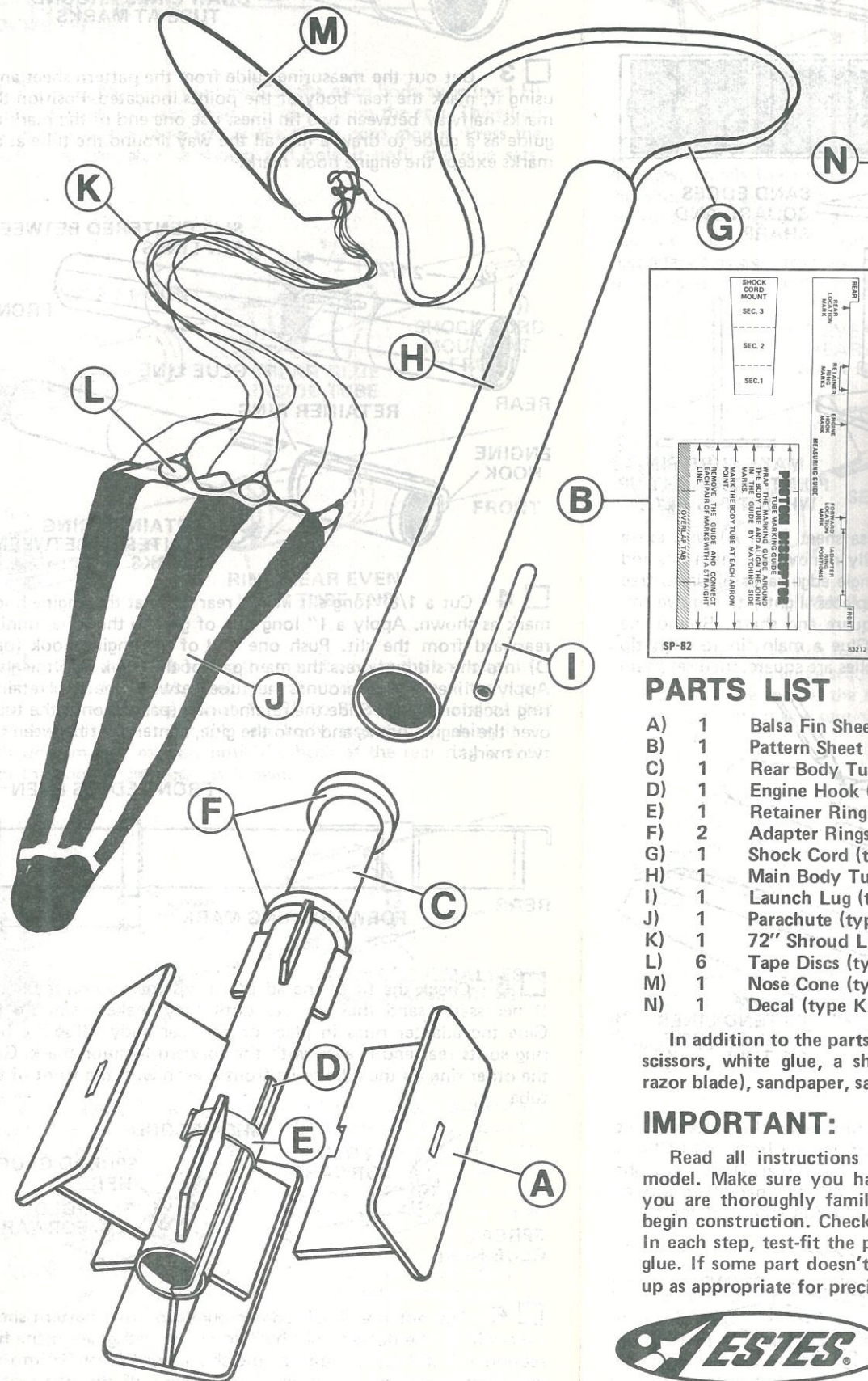

PN 37083
KD-82 ESTES

CAUTION
RADIATION-FLUX DEVICE

PHOTON DISRUPTOR
INTERSTELLAR TORPEDO
SPACE WEAPONS DIVISION

MOD. PTX-T1103
APP. RAD. 8-214

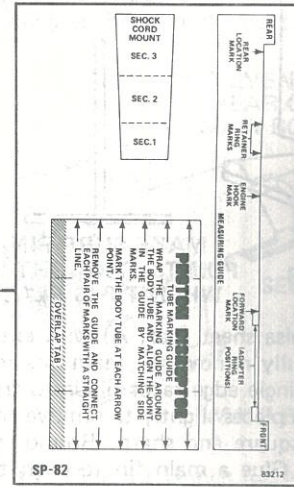

PARTS LIST

A)	1	Balsa Fin Sheet (type BF-82)	32243
B)	1	Pattern Sheet (type SP-82)	83212
C)	1	Rear Body Tube (type BT-20D)	30322
D)	1	Engine Hook (type EH-2)	35025
E)	1	Retainer Ring (type HR-20)	30168
F)	2	Adapter Rings (type AR-2050)	30164
G)	1	Shock Cord (type SC-1)	85730
H)	1	Main Body Tube (type BT-50W)	30372
I)	1	Launch Lug (type LL-2B)	38178
J)	1	Parachute (type PK-12A)	85564
K)	1	72" Shroud Line Cord (type SLT-72) ..	38237
L)	6	Tape Discs (type TD-3F)	38406
M)	1	Nose Cone (type PNC-50X)	71010
N)	1	Decal (type KD-82)	37083

In addition to the parts included in this kit you will need scissors, white glue, a sharp model knife (or single edge razor blade), sandpaper, sanding sealer, and paint.

IMPORTANT:

Read all instructions before beginning work on your model. Make sure you have all parts and materials. When you are thoroughly familiar with the assembly procedure, begin construction. Check off each step as you complete it. In each step, test-fit the parts together before applying any glue. If some part doesn't fit properly, sand lightly or build up as appropriate for precision assembly.



A SUBSIDIARY OF DAMON

ESTES INDUSTRIES
PENROSE, COLO. 81240

ASSEMBLY INSTRUCTIONS

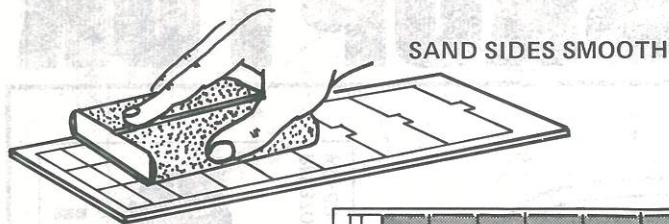

REMOVE MAIN
FINS AND
TIP PLATES

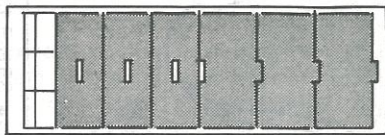

SAND EDGES
SQUARE AND
SHARP



MAIN FIN

TIP PLATE
CORNERS
ROUNDED



GLUE WITH TAB
IN SLOT

MAKE SURE FIN
POINTS STRAIGHT UP
WHEN TIP IS FLAT

1 Sand both sides of the balsa sheet (part A) with extra fine sandpaper until smooth. Carefully remove the main fins and tip plates, using a sharp knife or single edge razor blade to free the edges. Sand the edges of the fin pieces slightly to remove any rough spots, but leave the edges square and sharp. Round the corners of the tip plates slightly. Glue a main fin to each tip plate as shown. Make sure the assemblies are square, then set them aside to dry.

MARK TUBE AT ARROW POINTS

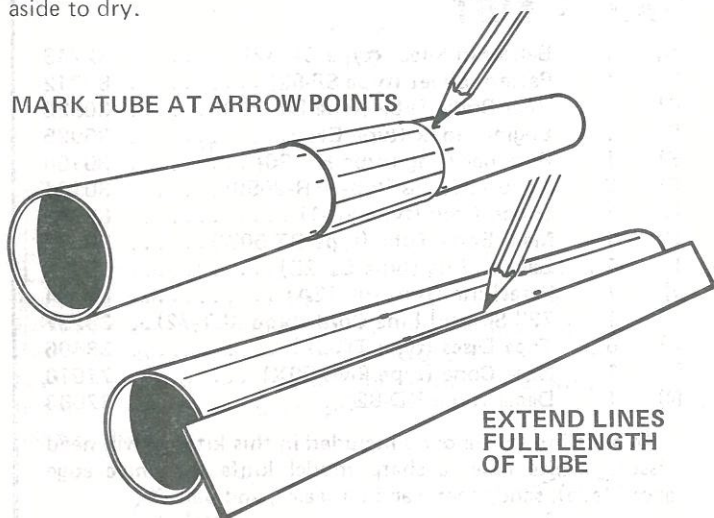

EXTEND LINES
FULL LENGTH
OF TUBE

2 Cut out the tube marking guide from the pattern sheet (part B). Wrap it around the middle of the rear body (part C) and mark the tube at each arrow point, front and rear. Draw a straight line connecting each matching front and rear mark (Use a ruler when drawing lines.) and extending the full length of the tube.

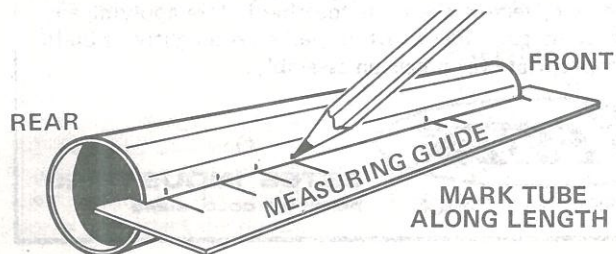

REAR

FRONT

MEASURING GUIDE

MARK TUBE
ALONG LENGTH

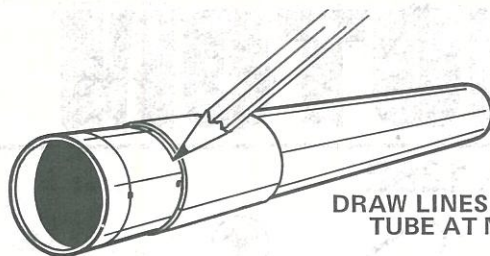

DRAW LINES AROUND
TUBE AT MARKS

3 Cut out the measuring guide from the pattern sheet and, using it, mark the rear body at the points indicated. Position the marks halfway between two fin lines. Use one end of the marking guide as a guide to draw a line all the way around the tube at all marks except the engine hook mark.

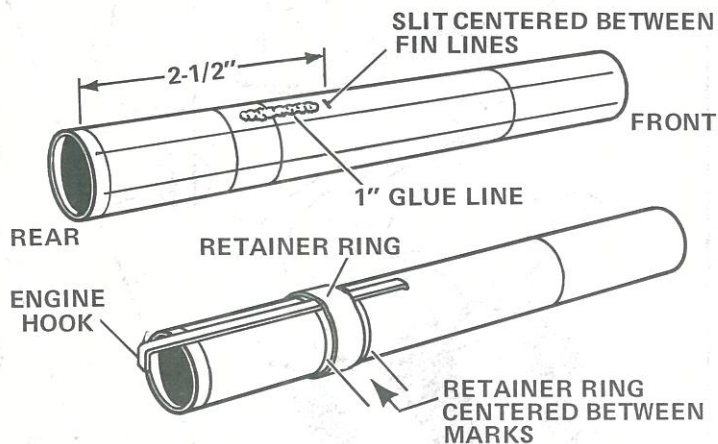

SLIT CENTERED BETWEEN
FIN LINES

2-1/2"

FRONT

1" GLUE LINE

REAR

RETAINER RING

ENGINE
HOOK

RETAINER RING
CENTERED BETWEEN
MARKS

4 Cut a 1/8" long slit in the rear body at the engine hook mark as shown. Apply a 1" long line of glue to the tube running rearward from the slit. Push one end of the engine hook (part D) into the slit and press the main part of the hook into the glue. Apply a line of glue around the tube between the two retainer ring location marks. Slide the retainer ring (part E) onto the tube, over the engine hook, and onto the glue, centering it between the two marks.

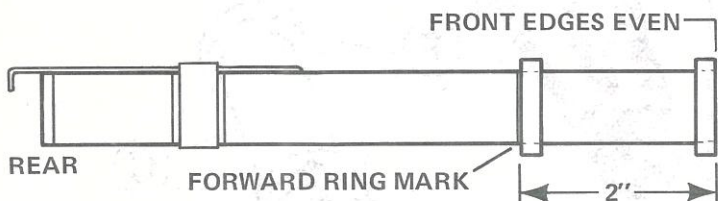

FRONT EDGES EVEN

REAR

FORWARD RING MARK

2"

5 Check the fit of the adapter rings (part F) on the body. If necessary, sand their insides until they make a smooth fit. Glue the adapter rings in place on the rear body. Glue the first ring so its rear end is even with the forward location mark. Glue the other ring on the tube so its front is even with the front of the tube.

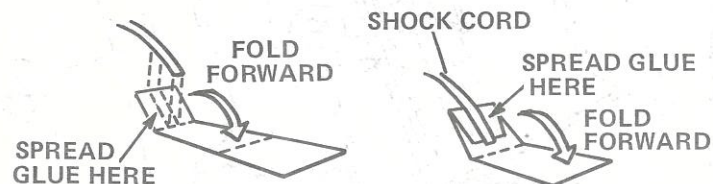

SHOCK CORD

FOLD
FORWARD

SPREAD GLUE
HERE

FOLD
FORWARD

SPREAD
GLUE HERE

6 Cut out the shock cord mount from the pattern sheet. Crease it on the dotted lines by folding. Spread glue on the first section (1) and lay the end of the shock cord (part G) into the glue. Fold over and apply glue to the back of the first section and the exposed part of section 2. Clamp the unit together with your fingers until the glue sets.

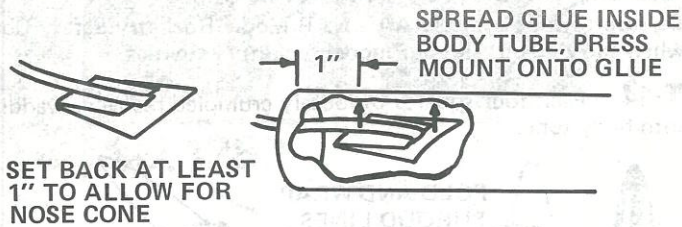

- 7** Apply glue to the inside of the main body tube (part H) at one end over an area about 1" to 2" from the end. The glued area should be the same size as the shock cord mount. Press the mount into the glue as shown and hold it until the glue sets.

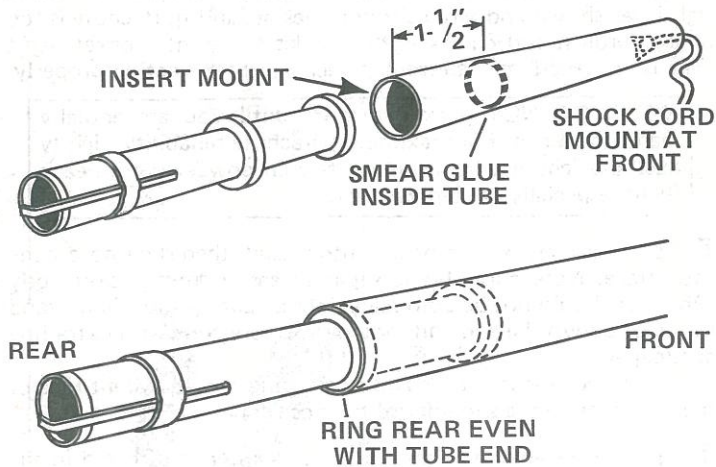

- 8** Glue the rear body to the main body (at the end opposite the shock cord mount). Smear glue around the inside of the main body to cover an area about 1-1/2" to 2" from the end of the tube. Immediately insert the rear body assembly, pushing it in with one smooth motion until the back of the rear ring is even with the end of the body as shown.

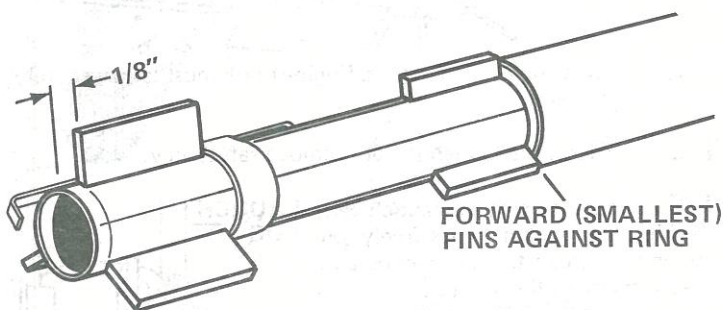

- 9** Carefully remove the secondary fins from the balsa sheet. Sand their edges square and smooth. Glue the secondary fins to the rear body, positioning them next to alternate (every other) alignment lines. The smaller fins are glued to the tube even with the adapter ring; the larger ones are positioned with their rear ends on the rear location mark. Smaller fins should be next to the same alignment lines as the larger secondary fins.

Construction Hint: When gluing fins on the body, first apply a line of glue to the root edge (the edge that attaches to the body). Let this glue set a moment, then rub it into the wood with your finger. Do this to all the fins. Then apply another line of glue to a fin, hold it a moment, and press it firmly into place on the body, using the lines to make sure the fin is straight.

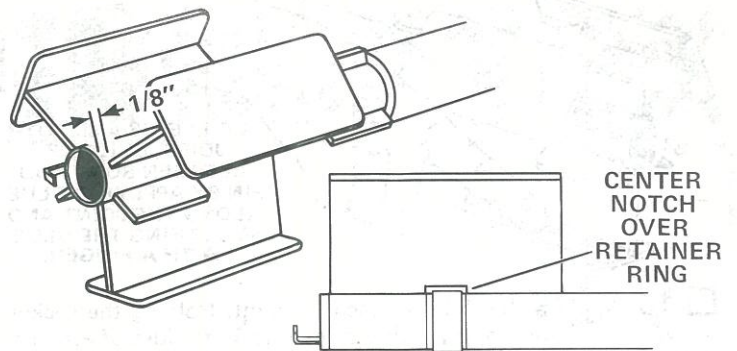

- 10** When the glue on the secondary fins has dried a few minutes, attach the main fin assemblies. The rear of each main fin should be even with the rear location mark, with the notch approximately centered over the retainer ring. Be careful to position the main fins to the same side of their alignment lines as the secondary fins were from theirs so all fins are spaced evenly around the body as shown in the next illustration.

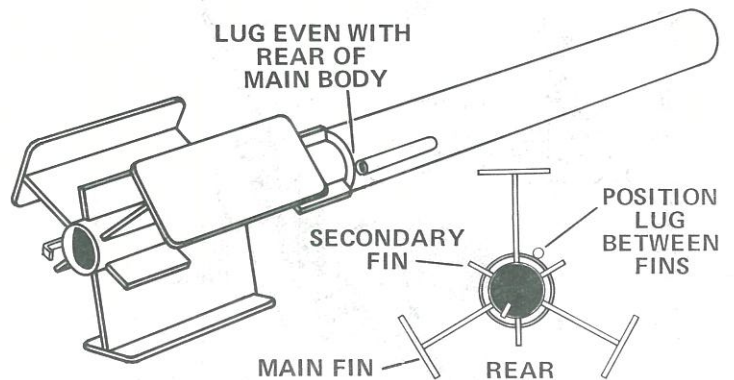

- 11** Glue the launch lug (part I) to the main body, centered between a main fin and a secondary fin. The rear of the lug should be even with the rear of the main body. Sight through the lug as you position it; make sure that it is straight on the body and between fins.

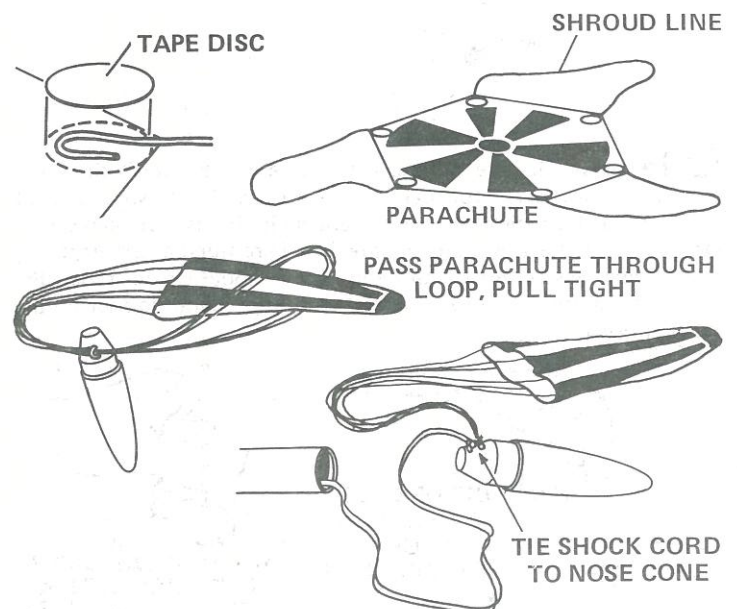

- 12** Cut out the parachute (part J) on its edge lines. Cut three 24" lengths of shroud line (part K). Attach line ends to the top of the parachute with tape discs (part L) as shown. Pass the shroud line loops through the ring on the nose cone (part M). Pass the parachute through the loop ends and draw the lines tight against the ring. Set the knot with a drop of glue. Tie the free end of the shock cord to the nose cone.

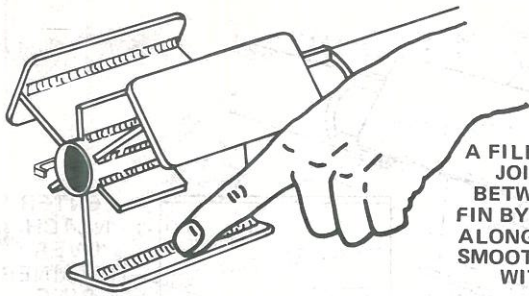

A FILLET IS A SMOOTH JOINT, BUILT UP BETWEEN BODY AND FIN BY APPLYING GLUE ALONG THE JOINT AND SMOOTHING THE GLUE WITH A FINGER.

□ 13 Apply a glue fillet to each fin joint. Holding the rocket horizontally (level), apply a line of glue to both sides of each fin joint. Smooth out the glue with your finger. Keep the rocket level until the glue dries.

WHITE—OVERALL ROCKET
ORANGE—1/8" ABOVE MAIN BODY
TUBE REAR AND 4-1/4"
FROM BODY TUBE FRONT

PLACE "CAUTION" DECAL ON OPPOSITE SIDE OF BODY.

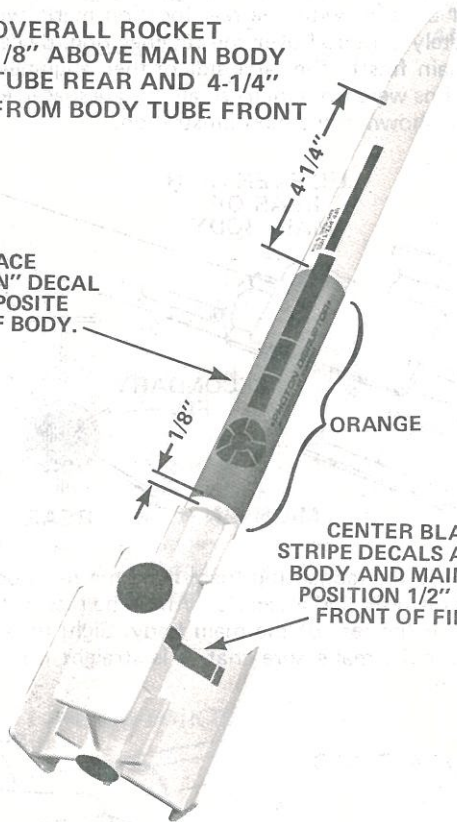

ORANGE

CENTER BLACK STRIPE DECALS ACROSS BODY AND MAIN FINS, POSITION 1/2" FROM FRONT OF FINS.

□ 14 When all glue on the outside of the model is dry, prepare the balsa parts for painting. Apply at least two coats of sanding sealer to the fins. Let dry and sand lightly between coats. Do this until the tiny holes in the wood are filled and everything looks and feels smooth. Paint the entire model white. When the white is completely dry, apply the orange band shown in the above photo.

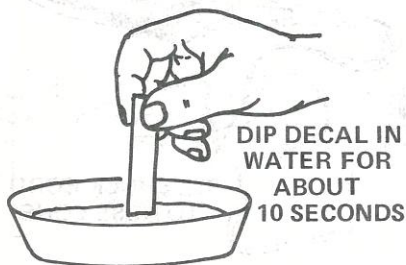

DIP DECAL IN WATER FOR ABOUT 10 SECONDS



HOLD DECAL UNTIL IT UNCURLS, THEN SLIDE IT OFF BACKING PAPER INTO POSITION

□ 15 When all paint is dry, apply decals (part N) as shown in the photo. Cut out a decal section, dip it in lukewarm water for 20 seconds, and hold it until it uncurls. Slip the decal off the backing sheet and onto the model. Blot excess water away. For best results, let the model dry overnight and apply a coat of clear spray to protect the decals.

COUNTDOWN CHECKLIST

Be sure to follow the HIAA - NAR Model Rocketry Safety Code when carrying out all your model rocketry activities.

T-14 Pack four squares of loosely crumpled recovery wadding into body tube.



FOLD AND WRAP SHROUD LINES AROUND PARACHUTE



INSERT AFTER WADDING

T-13 Fold the parachute into a triangular shape. Fold 'chute tightly as shown and wrap shroud lines around it. If 'chute is too large, unroll it and repack until it slides easily into rocket. A fit that is too tight may prevent parachute from ejecting properly.

NOTE: DO NOT pack parachute until you are actually ready to launch. For maximum parachute reliability, lightly dust the 'chute with ordinary talcum powder before each flight, especially in cold weather.

T-12 Pack shock cord neatly into rocket, then slide nose cone into place. Nose cone should separate easily from rocket body tube, but should not be extremely loose. If it is too tight, sand inside of body tube end and shoulder of nose cone with extra fine sandpaper.

If nose cone is too loose add a wrapping of transparent tape or masking tape to the shoulder of the nose cone.

T-11 Select an engine and install an igniter as directed in the engine instructions. Engines recommended for use with this rocket are the 1/2A6-2, A8-3, B4-4, B6-4, and C6-5 made by Estes.

Use an A8-3 engine for your first flight.

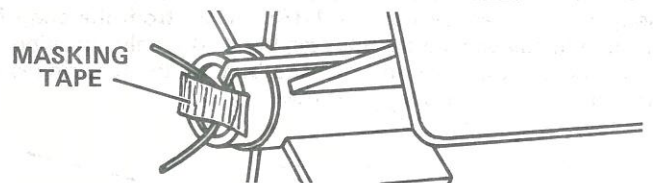

MASKING TAPE

T-10 Insert engine into rocket. Engine hook must latch securely over end of engine.

T-9 Disarm the launch panel--remove safety key.

T-8 Place rocket on launch pad, LAUNCH LUG making sure rocket slides freely on launch rod. Clean the micro-clips and attach them to the igniter.

PLACE MASKING TAPE AROUND ROD TO SUPPORT ROCKET REAR 1" ABOVE BLAST DEFLECTOR

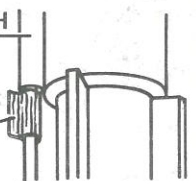

T-7 Clear the launch area, alert recovery crew and trackers. Check for low flying aircraft and unauthorized persons in the recovery area.

T-6 Arm the launch panel--insert safety key.

5 4 3 2 1 LAUNCH!!

MISFIRE PROCEDURE

Occasionally the igniter will heat and burn in two without igniting the engine. This is almost always caused by a failure to install it correctly. Disarm the launch panel, remove the model, clean the igniter residue from the nozzle, and install a new igniter. Follow the launching procedure again.