

DECOR ILLUSTRATION

TO APPLY DECALS:

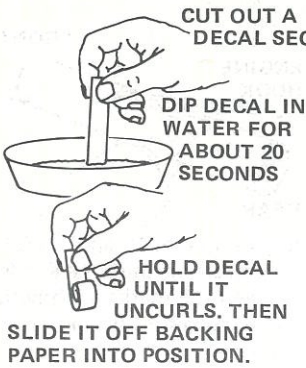

PAINT SCHEME

GLOSS WHITE – MAIN BODY
 GLOSS RED – NOSE CONE
 GLOSS BLACK – FIN SECTION

USE BAND 'LOCATER LINE' TO POSITION PANEL DECALS. SAME BOTH SIDES.

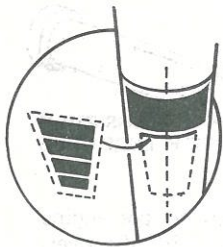

CENTER RESCUE DECAL 3/8" ABOVE BLACK BAND. SAME BOTH SIDES.

NOTE: POSITION GAPS IN BLACK BODY BAND IN-LINE WITH CENTER-LINE AS SHOWN. SAME BOTH SIDES

TOP FIN

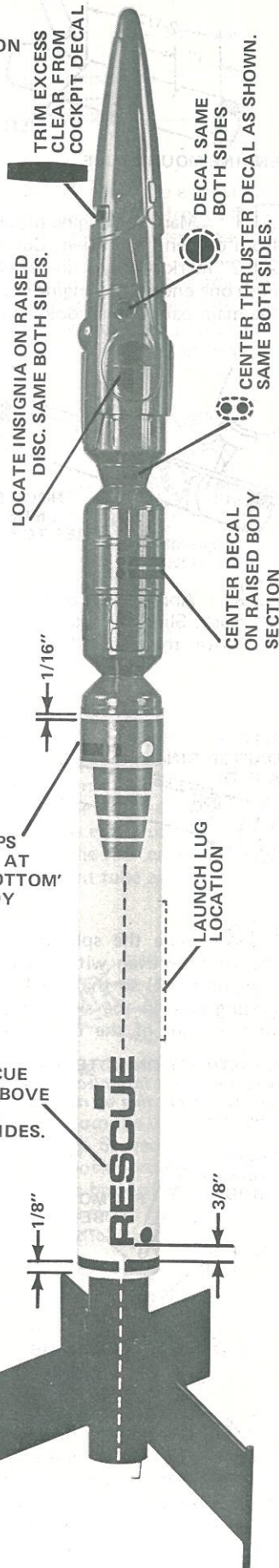

A SUBSIDIARY OF DAMON

Odyssey

SPACESHIP

flying model rocket kit

KIT NO. 1289

SKILL LEVEL 2 - This kit is suggested for Intermediate Rocketeers.

The Odyssey spaceship, as its name suggests, is a stellar wanderer of the far future. It is envisioned to perform a variety of space rescue, exploratory, or intruder intercept missions. The impulse power unit jettisons after trajectory insertion. Its two-man crew and engineering section then accelerates to near-light velocities. Mission complete, Odyssey returns for orbital refurbishment or touchdown on a low gravity planet.

Your Odyssey spaceship is constructed of lightweight modeling materials such as balsa wood, paper tubing and some plastic. This model rocket has a parachute recovery system so that it can be launched and safely recovered many times. A safe, single-use, solid propellant engine is used to launch the rocket. Ignited electrically, the engine automatically provides thrust for quick lift-off and acceleration, allows for a timed delay period to reach peak altitude while delivering a smoke trail for easy tracking, and finally supplies ejection power to activate the recovery system.

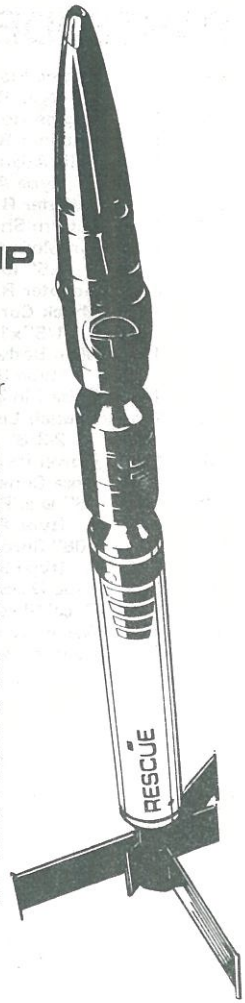

TOOLS AND MATERIALS

In addition to the parts included in this kit you will need white glue, pen or pencil, scissors, a sharp model knife (or single edge razor blade), a ruler, masking tape, sandpaper, sanding sealer, and paint as noted in the Decor Illustration.

LAUNCHING COMPONENTS

You will need the following launching supplies to fly your ODYSSEY model rocket:

-An Estes remote-control electrical launch system and the recommended battery.

-Parachute recovery wadding (Estes Cat. No. 2274).

-Estes B4-4, B6-4, or C6-5 model rocket engines and igniters. (Igniters are included with all Estes engines.) Use a B6-4 engine for the first flight.

Be sure to follow the *HIAA-NAR Model Rocketry Safety Code when carrying out your Miniature Astronautics activities.

*HIAA-NAR - Hobby Industry Association of America
 - National Association of Rocketry

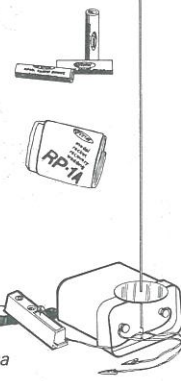

BEFORE YOU START

Read all instructions before beginning work on your model. Make sure you have all parts and materials. When you are thoroughly familiar with the assembly procedure, begin construction. Check off each step as you complete it. In each step, test-fit the parts together before applying any glue. If some part doesn't fit properly, sand lightly or build up as appropriate for precision assembly.

ESTES INDUSTRIES, PENROSE, COLORADO 81240

PARTS IDENTIFICATION

A)	1	Engine Mount Tube (type BT-20DJ) 4.0" long ...	30332
B)	1	Engine Hook (type EH-2)	35025
C)	1	Retainer Ring (type HR-20)	30168
D)	1	Split Adapter Ring (type AR-2050S)	80425
E)	1	Adapter Ring (type AR-2050) ...	30164
F)*	1	Pattern Sheet (type SP-89)	83235
G)	1	Fin Mount Tube (type BT-50EE) 5.5" long	30358
H)	2	Adapter Rings (type AR-5055) ..	30166
I)	1	Shock Cord (type SC-1) 1/8"x18"	85730
J)	1	Main Body Tube (type BT-551J) 9.0" long ...	30384
K)	1	Balsa Fin Sheet (type BF-89) ...	32297
L)	1	Launch Lug (type LL-2B) 2-3/8" long	38178
M)	1	Dowel (type WD-1C) 1/8"x6" ...	85906
N)	1	Nose Cone (type PNC-55CB) ...	71036
O)	1	18" Dia. Parachute (type PK-18A)	85566
P)	1	108" Shroud Line (type SLT-108)	38239
Q)	6	Tape Discs (type TD-3F)	38406
R)*	1	Decal Sheet (type KD-89)	37095
S)*	1	Assembly Instructions	83234
T)*	1	Countdown Checklist	83240

*Included in kit, but not illustrated

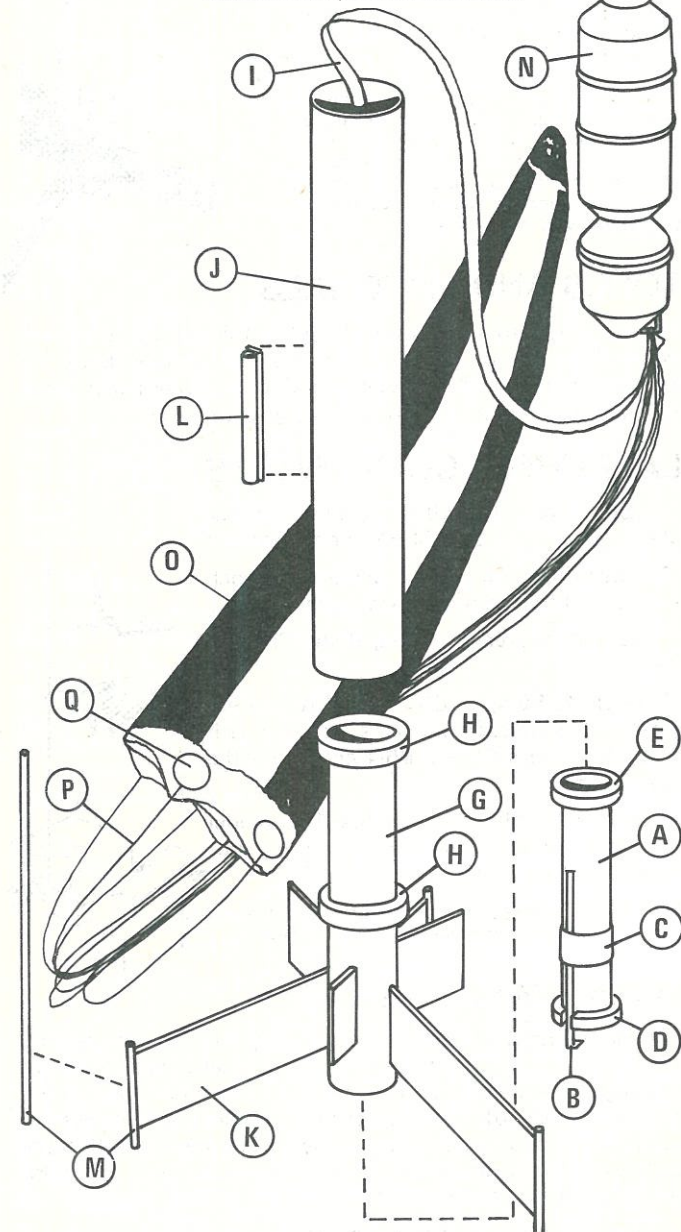

ASSEMBLY INSTRUCTIONS

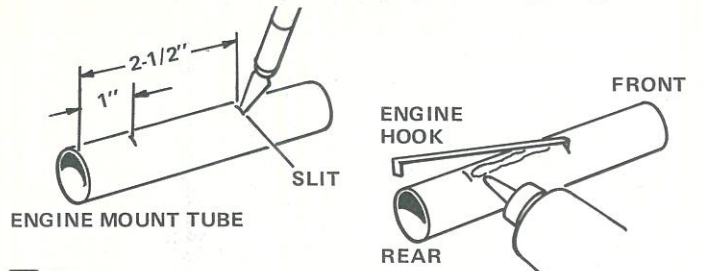

1 Mark the engine mount tube (part A) at 1" and 2-1/2" from one end as shown. Cut a 1/8" long slit in the tube at the 2-1/2" mark. Apply a line of glue between the marks as shown. Push one end of the engine hook (part B) into the slit and press the main part of the hook into the glue.

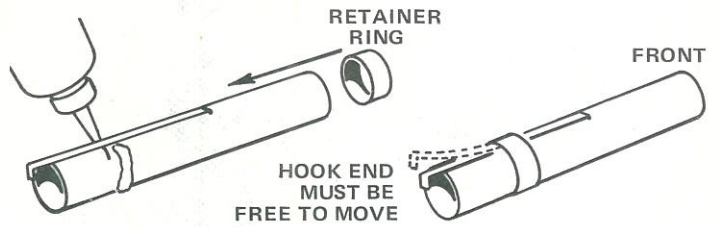

2 Apply a line of glue around the tube just ahead of the 1" mark. Slide the retainer ring (part C) onto the tube, centering it over the glue and next to the 1" mark.

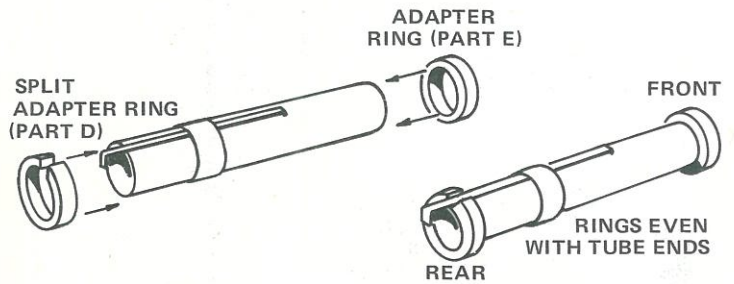

3 Glue the split adapter ring (part D) to the engine mount tube even with the rear end (the end with the overhanging hook) so that the hook passes through the slot. Avoid getting glue in the slot. Glue the other adapter ring (part E) to the front of the tube, even with the tube end as shown.

CONSTRUCTION NOTE: Check the fit of each adapter ring in the kit before gluing it into place as instructed. If necessary, sand the inside or outside of the ring as required until it makes a smooth fit with the body tube.

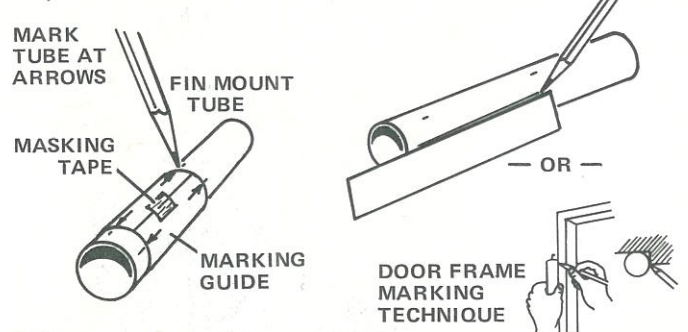

4 Cut out the fin marking guide from the pattern sheet (part F). Wrap it around one end of the fin mount body tube (part G). Use a short strip of masking tape to hold the guide ends together as shown. Mark the tube at each arrow point, front and rear. Draw a straight line connecting each matching front and rear mark. Use a ruler or the edge of a door frame when drawing lines.

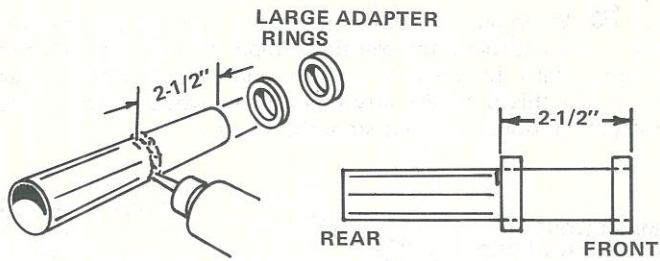

5 Mark the fin mount tube 2-1/2" from the end which is not marked with fin lines. This end will be the front of the assembly. Apply a line of glue around the tube, just ahead of the mark, as shown. Slide one of the large adapter rings (part H) onto the front end of the tube. Push it along in one smooth motion into the glue until the back of the ring is even with the 2-1/2" mark. Wipe away any excess glue from the joint. Glue the other large adapter ring to the tube so that it is even with the front end.

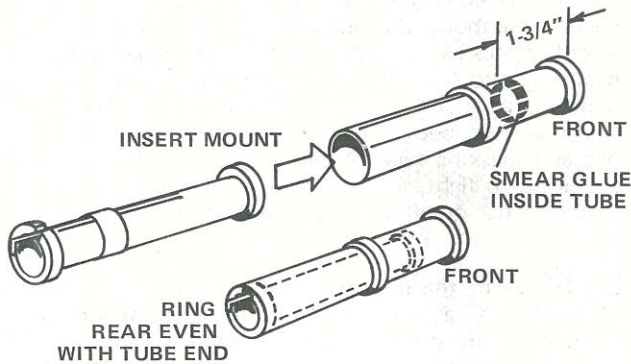

6 Glue the engine mount assembly into the fin mount tube. Smear a 1/4" wide band of glue around the inside of the fin mount tube, 1-3/4" from the front end. Use the end of a small stick or paint brush to apply the glue. Immediately insert the engine mount into the OTHER tube end. Push it in with one smooth motion until the back of the rear engine mount ring is even with the rear of the fin mount tube as illustrated.

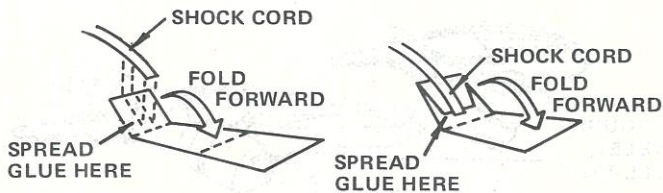

7 Cut out the shock cord mount from the pattern sheet. Crease it on the dotted lines by folding. Spread glue on the first section (1) and lay the end of the shock cord (part I) into the glue. Fold over and apply glue to the back of the first section and exposed part of section 2. Lay the shock cord as shown and fold over again. Clamp the unit together with your fingers until the glue sets.

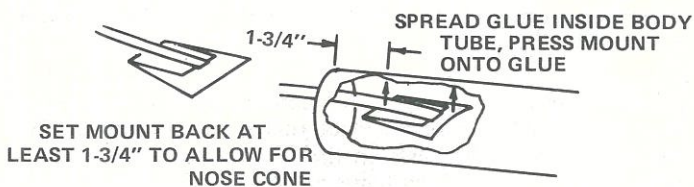

8 Apply glue to the inside of the main body tube (part J) at one end to cover an area about 1-3/4" to 2-3/4" from the end. The glued area should be the same size as the shock cord mount. Press the mount into the glue as shown. Hold it until the glue sets.

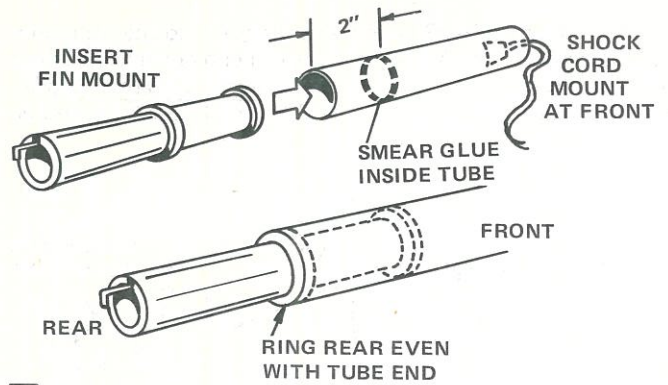

9 Glue the fin mount assembly to the main body (at the end opposite the shock cord mount). Smear a 1/4" wide band of glue around the inside of the main body, 2" from the rear end of the tube. Immediately insert the fin mount unit, pushing it in with one smooth motion until the back of the large rear ring is even with the end of the body as shown.

IMPORTANT: DO NOT PUSH BALSA PARTS FROM DIE-CUT SHEET. USE A MODELING KNIFE TO FREE ALL PART EDGES BEFORE REMOVING THEM.

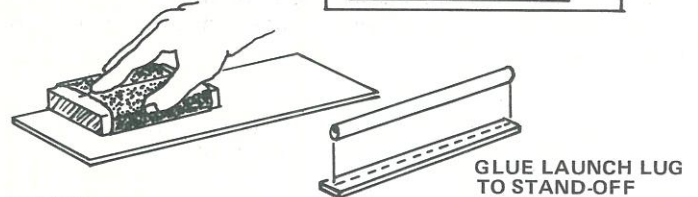

10 Sand both sides of the balsa fin sheet (part K) with fine sandpaper until smooth. Carefully remove the fin pieces and launch lug stand-off, using a sharp knife or single edge razor blade to free the edges. Sand the edges of all pieces slightly to remove any rough spots, but leave the edges square and sharp. Apply a line of glue along the launch lug (part L). Glue the lug to one flat side of the balsa stand-off so that it is centered and parallel to the balsa edges.

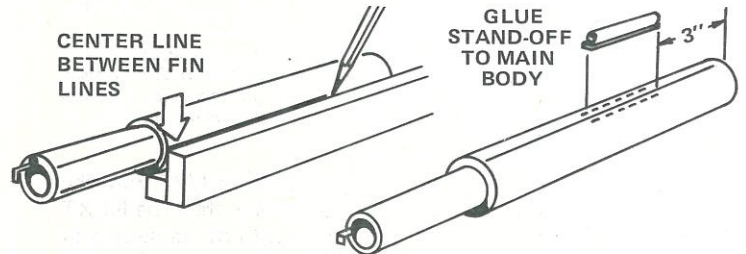

11 Draw a straight line along the entire length of the main body tube. The edge of a desk drawer front or a door frame makes a suitable guide for drawing the line. (Use a lead pencil line because ball-point pen ink may bleed through the white paint finish.) Center the line between two of the alignment lines on the fin mount tube. Glue the launch lug stand-off to the main body, centered on the line and 3" from the front end as shown.

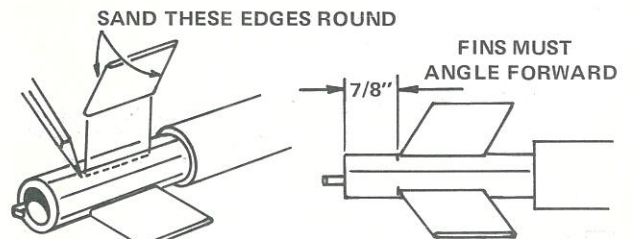

NOTE: SEE ALSO STEP #14 CONSTRUCTION HINT

12 Sand round the two short edges of each small secondary fin. Leave the longer edges square and sharp. Mark each alternate (every other) fin alignment line, 7/8" from the rear

of the fin mount tube. Glue the secondary fins to the fin mount tube. Position them NEXT TO their alignment lines, each to the same side of its line. The fins should angle forward as shown, with the rear edge even with the 7/8" mark. Each fin should project straight away from the fin tube.

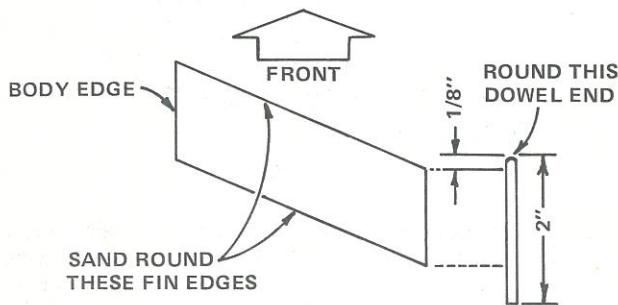

13 Use fine sandpaper to sand both long edges (leading and trailing edge) of each main fin until they are rounded. Leave the shorter edges square and sharp. Cut three 2" long pieces from the 1/8" diameter wood dowel (part M). Sand one end of each dowel round. Glue one dowel to one short edge of each fin as shown. The rounded end of the dowel should project 1/8" forward from the leading edge (front edge) of the fin. Temporarily tape each dowel in position with a short strip of masking tape until the glue dries.

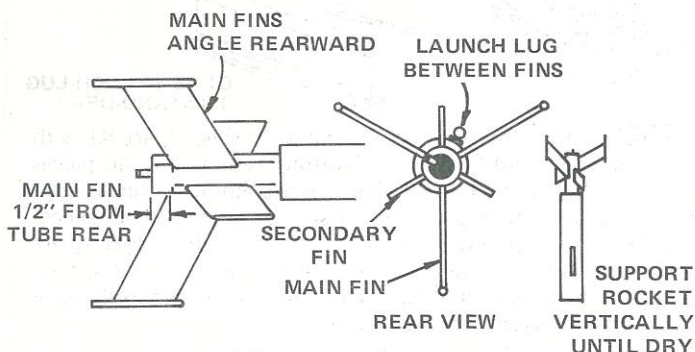

CONSTRUCTION HINT: When gluing fins on the body, first apply a line of glue to the root edge (the edge that attaches to the body). Let this glue set a moment, then rub it into the wood with your finger. Do this to all the fins. Then apply another line of glue to a fin, hold it a moment, and press firmly into place on the body, using the lines to make sure the fin is straight.

14 Mark the remaining fin alignment lines 1/2" from the rear of the fin mount tube. Glue the main fins to the tube NEXT TO their alignment lines. Position each fin to the same side of its line as the secondary fins were from theirs so all fins are spaced evenly around the body. Each fin should angle rearward as shown, with the rear edge even with the 1/2" mark. All fins should project straight away from the fin mount tube as illustrated in the rear view. Support the main rocket body vertically until fins are dry.



15 When the fin joints have dried, apply glue reinforcements to each main fin joint. Holding the fin mount assembly level, apply a narrow line of glue to both sides of each fin joint. Smooth out the glue with your finger. Keep the fin assembly level until the glue dries.

16 When all glue joints on the fin assembly are dry, prepare the balsa parts for painting. Apply at least two coats of sanding sealer to the fins. Let dry and sand lightly between coats. Do this until the tiny holes in the wood are filled and everything looks and feels smooth.

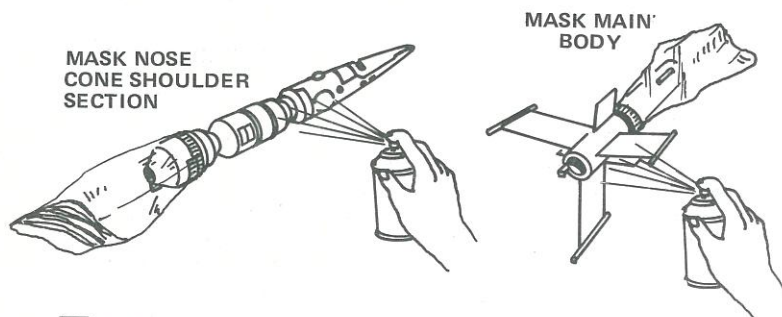

17 Trim any "flash" or excess plastic from the molded plastic nose cone (part N). Wash the nose cone in mild soapy water, rinse thoroughly and dry completely with a clean towel. Avoid unnecessary handling of the nose cone after washing to keep dirt and skin oils from interfering with the paint finish. Mask the nose cone shoulder section (part of nose cone which fits into main body) with newspaper or plastic dry cleaning bag and masking tape. Apply a base coat of gloss red spray enamel with light, even passes over the nose cone. When the base coat has dried, apply a final coat of gloss red in the same way.

18 Paint the main rocket body with two light coats of gloss white spray enamel. Allow the paint to dry overnight. When the paint is completely dry, mask the entire main body tube with newspaper or plastic dry cleaning bag and masking tape. Paint the entire fin assembly section with two light coats of gloss black spray enamel.

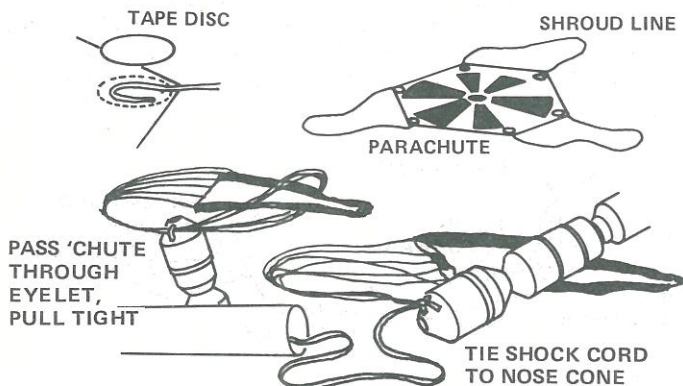

19 Cut out the parachute (part O) on its edge lines. Cut three 36" lengths of shroud line (part P). Attach line ends to the top of the parachute with tape discs (part Q) as shown. When all paint on the model is dry, pass the shroud line loops through the eyelet on the nose cone. Pass parachute through the loop ends and draw lines tight against the eyelet. Set the knot with a drop of glue. Tie the free end of the shock cord to the nose cone.

20 Pack parachute and shock cord neatly into main body. Slide nose cone into place. Place rocket temporarily on flat surface so that model rests on fin tips and nose cone. Rotate entire rocket until launch lug is at bottom of model. The fin which projects straight away from the flat surface will be the "top fin". Now rotate nose cone only, until the recessed cockpit detail is in line with the "top fin". Apply decals (part R) as shown in the Decor photo. For best results, blot away excess water and let the model dry overnight. Apply a final coat of clear spray to protect the decals.