

# GOBRA-1500

**KIT NO. 1294**

**Skill Level 2**

This kit recommended for intermediate skilled rocketeers.

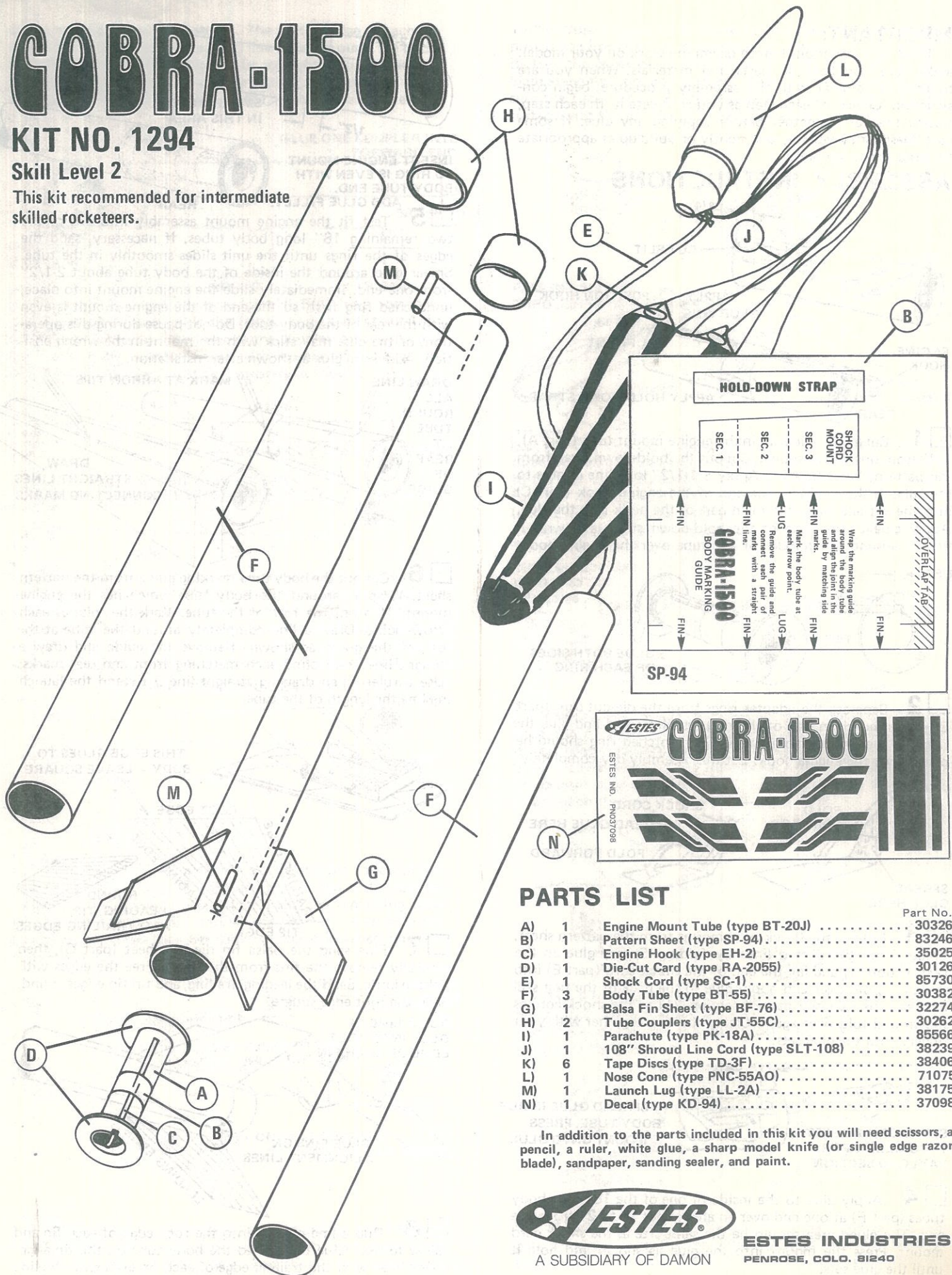

## PARTS LIST

		Part No.
A)	1	Engine Mount Tube (type BT-20J) . . . . . 30326
B)	1	Pattern Sheet (type SP-94) . . . . . 83246
C)	1	Engine Hook (type EH-2) . . . . . 35025
D)	1	Die-Cut Card (type RA-2055) . . . . . 30126
E)	1	Shock Cord (type SC-1) . . . . . 85730
F)	3	Body Tube (type BT-55) . . . . . 30382
G)	1	Balsa Fin Sheet (type BF-76) . . . . . 32274
H)	2	Tube Couplers (type JT-55C) . . . . . 30262
I)	1	Parachute (type PK-18A) . . . . . 85566
J)	1	108" Shroud Line Cord (type SLT-108) . . . . . 38239
K)	6	Tape Discs (type TD-3F) . . . . . 38406
L)	1	Nose Cone (type PNC-55AO) . . . . . 71075
M)	1	Launch Lug (type LL-2A) . . . . . 38175
N)	1	Decal (type KD-94) . . . . . 37098

In addition to the parts included in this kit you will need scissors, a pencil, a ruler, white glue, a sharp model knife (or single edge razor blade), sandpaper, sanding sealer, and paint.



A SUBSIDIARY OF DAMON

**ESTES INDUSTRIES**  
PENROSE, COLO. 81240

## IMPORTANT:

Read all instructions before beginning work on your model. Make sure you have all parts and materials. When you are thoroughly familiar with the assembly procedure, begin construction. Check off each step as you complete it. In each step, test-fit the parts together before applying any glue. If some part doesn't fit properly, sand lightly or build up as appropriate for precision assembly.

## ASSEMBLY INSTRUCTIONS

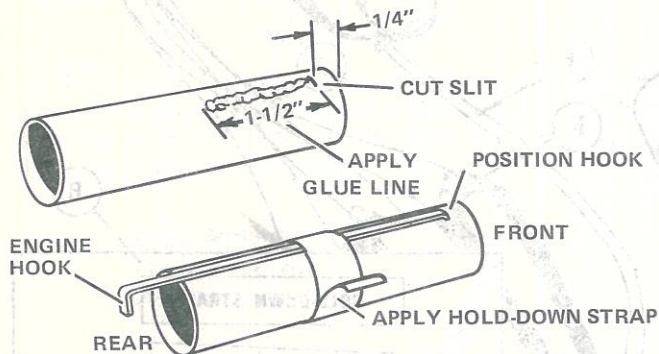

**1** Cut a 1/8" wide slit in the engine mount tube (part A), 1/4" from one end as shown. Cut out the hold-down strap from the pattern sheet (part B). Apply a 1-1/2" long line of glue to the tube as shown. Push one end of the engine hook (part C) into the slit and press the main part of the hook into the glue. Apply glue to one side of the hold-down strap, and wrap it tightly around the middle of the tube over the engine hook.

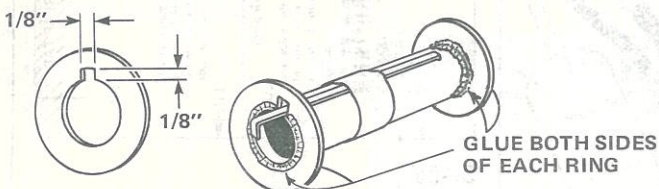

**2** Separate the adapter rings from the die-cut card (part D). Cut a notch in one of the rings as illustrated and glue the rings to the engine mount tube. The notched ring should be placed over the engine hook. Let this assembly dry completely.

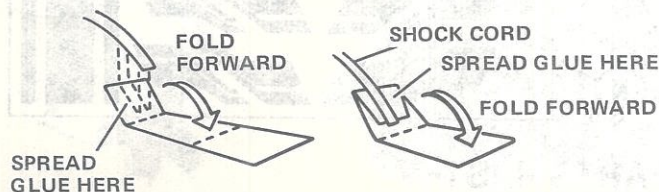

**3** Cut out the shock cord mount from the pattern sheet. Crease it on the dotted lines by folding. Spread glue on the first section (1) and lay the end of the shock cord (part E) into the glue. Fold over and apply glue to the back of the first section and the exposed part of section 2. Lay the shock cord as shown and fold over again. Clamp the unit together with your fingers until the glue sets.

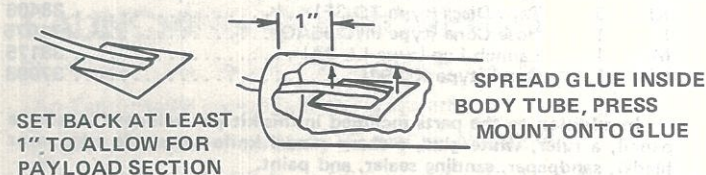

**4** Apply glue to the inside of one of the 18" long body tubes (part F) at one end over an area about 1" to 2" from one end. The glued area should be the same size as the shock cord mount. Press the mount into the glue as shown and hold it until the glue sets.

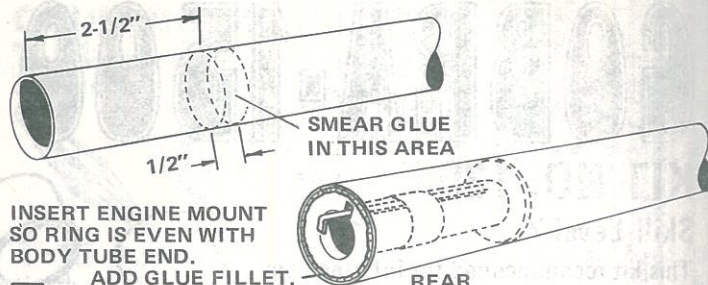

**5** Test fit the engine mount assembly into one of the two remaining 18" long body tubes. If necessary, sand the edges of the rings until the unit slides smoothly in the tube. Smear glue around the inside of the body tube about 2-1/2" from one end. Immediately slide the engine mount into place, unnotched ring first, so the end of the engine mount is even with the rear of the body tube. Do not pause during this operation, or the glue may stick with the mount in the wrong position. Add extra glue as shown after installation.

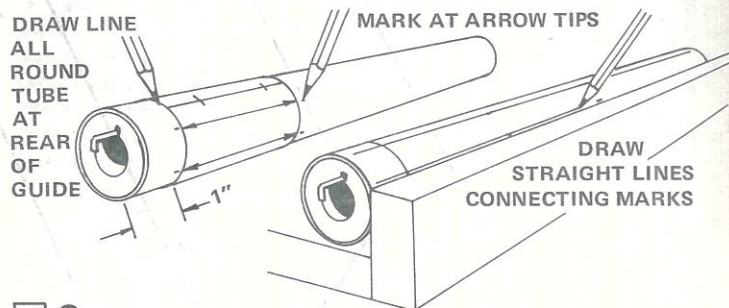

**6** Cut out the body tube marking guide from the pattern sheet. Wrap it around the body tube which has the engine mount, 1" from the rear of the tube. Mark the tube at each arrow point. Draw a line completely around the tube at the rear of the guide as shown. Remove the guide and draw a straight line connecting each matching front and rear marks. (Use a ruler when drawing straight lines.) Extend the launch lug line the length of the tube.

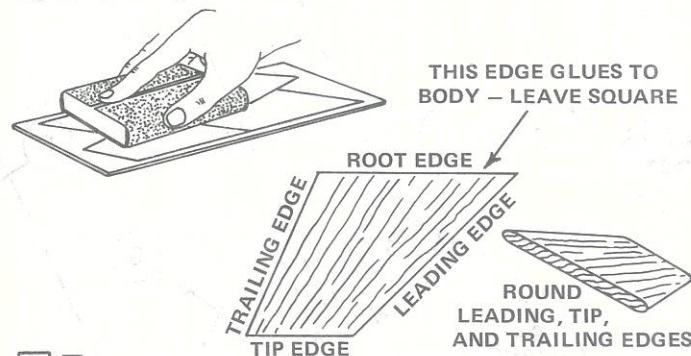

**7** Fine sand the balsa fin die-cut sheet (part G), then carefully remove the fins from the sheet. Free the edges with a sharp knife. Sand the leading, trailing, and fin tip edges round. Sand the root edge square.

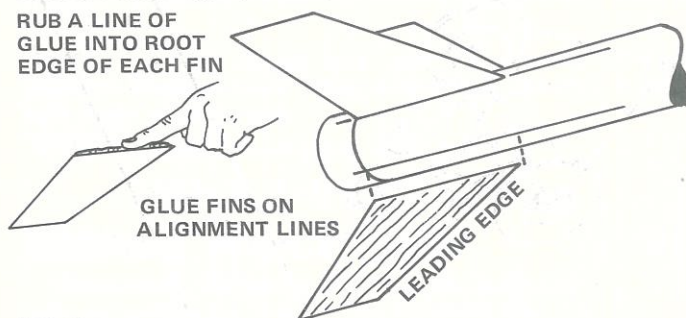

**8** Rub a line of glue into the root edge of each fin and allow to dry. Glue the fins to the body tube on the fin alignment lines with the trailing edge of each fin even with the line

drawn around the tube in step 6. The trailing edge of each fin should be on the one inch spacing line drawn around the body tube. Refer to the illustration to be sure you position the fins correctly. Adjust the fins so they project straight away from the body tube. Do not set the rocket on its fins while the glue is wet.

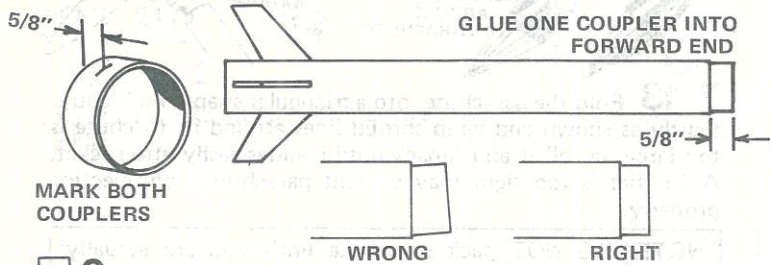

**9** Mark both tube couplers (part H), 5/8" from one edge. Smear a band of glue inside the finned body tube about 1/4" from the forward end. Insert one of the couplers and push until the mark on the coupler is even with the end of the tube. Be sure the tube coupler is installed squarely as shown.

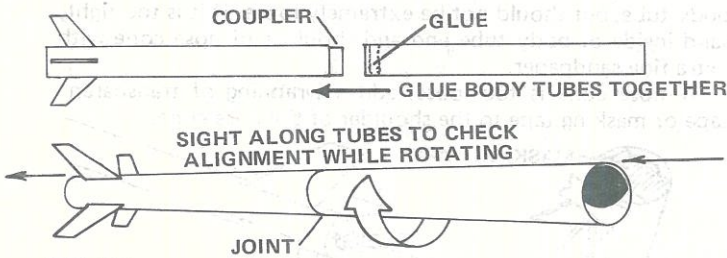

**10** Smear a band of glue inside one end of the unused 18" long body tube about 1/4" from the end. Slide this end of the tube over the coupler attached to the finned tube in one smooth movement. The edges of the two body tubes should touch all around. Sight along the tubes while rotating the rocket to be sure the alignment of the body tubes is perfectly straight.

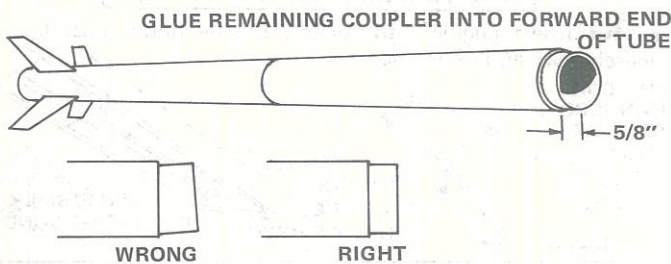

**11** Smear another band of glue around the inside of the tube about 1/4" from the forward end of the body tube attached to the finned body tube. Insert the remaining tube coupler and push until the mark on the coupler is even with the end of the tube. Be sure the tube coupler is installed squarely as shown.

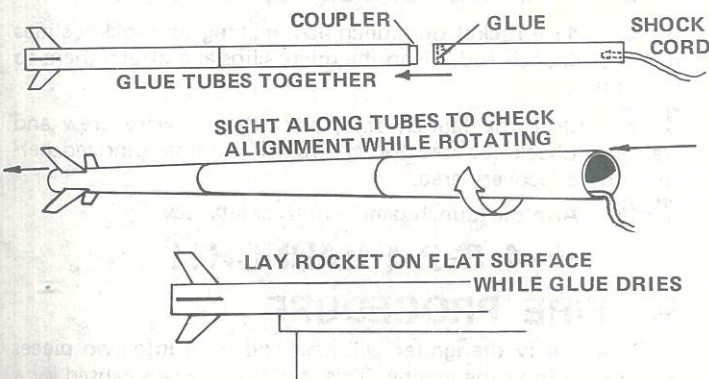

**12** Smear yet another band of glue around the inside of the tube with the shock cord mount at the end away from the shock cord mount. The glue band should be placed about

1/4" in from the end. Slide this end of the tube over the coupler protruding from the rocket assembly in one smooth movement. Be sure the edges of the mating body tubes touch all around. Sight along the completed rocket assembly while rotating to be sure the tubes are all aligned straight. Set the rocket on a flat surface with the fins over the edge while the glue dries.

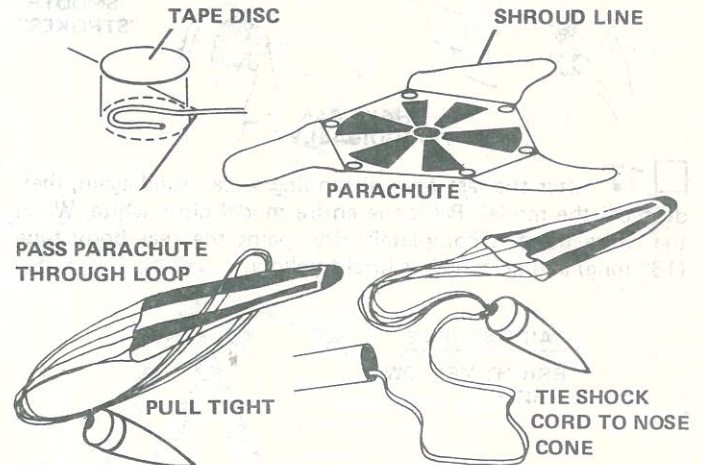

**13** Cut out the parachute (part I) on its edge lines. Cut three 36" lengths of shroud line (part J). Attach the line ends to the top of the parachute with tape discs (part K) as shown. Pass the shroud line loops through the ring on the nose cone (part L). Pass the parachute through the loop ends and draw the lines tight against the ring. Set the knot with a drop of glue. Tie the free end of the shock cord to the nose cone.

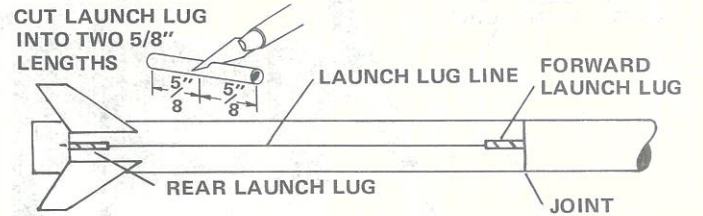

**14** Cut the launch lug (part M) into two 5/8" lengths. Glue one of these lugs on the launch lug alignment line with its rear edge even with the line drawn around the tube as shown. Glue the remaining lug on the launch lug alignment line with its forward edge even with the joint where the two body tubes meet. Align the lugs straight on the body tube.

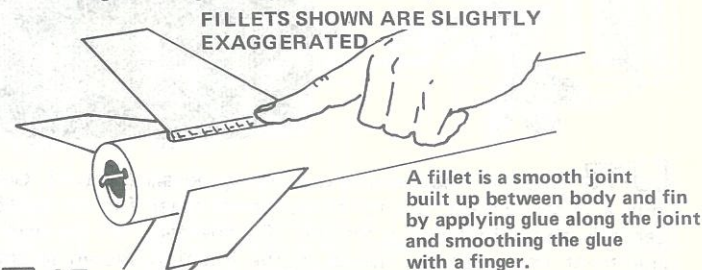

**15** Reinforce the fin joints with glue. Holding the rocket horizontally (level), apply a line of glue to both sides of each joint. Smooth out the glue with your finger. Keep the rocket level until the glue dries.



**16** When all glue on the outside of the model is dry, prepare the balsa parts for painting. Apply at least two coats of sanding sealer to the fins. Let dry and sand lightly between

coats. Do this until the tiny holes in the wood are filled and everything looks and feels smooth.

**SPRAY PAINT FOR BEST RESULTS**

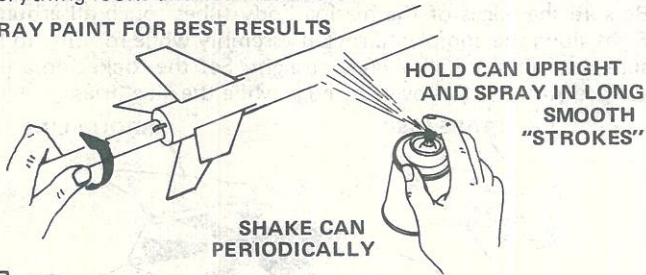

**17** After the last coat of sanding sealer, sand again, then dust off the model. Paint the entire model gloss white. When the white paint is completely dry, paint the rear body tube (18" long) and all four fins bright yellow.

**PAINT SCHEME**  
BRIGHT YELLOW  
WHITE

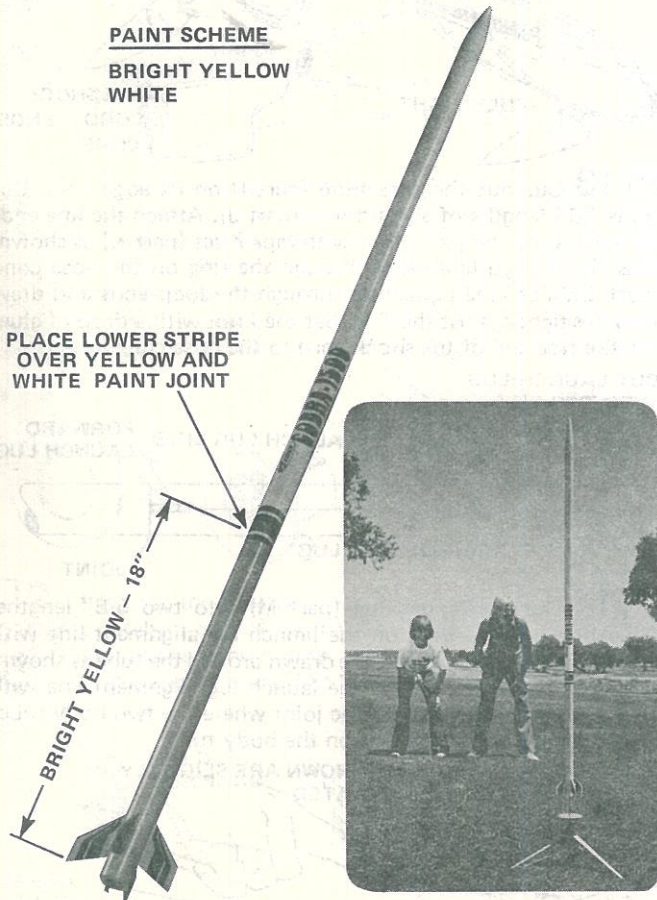

**18** When all the paint is dry, apply decals (part N). Cut out a decal section, dip it in lukewarm water for about 15 seconds, and hold it until it uncurls. Slip the decal off the backing sheet and onto the model in the location shown in the illustration. Blot away excess water. For best results, let the model dry overnight and apply a coat of clear spray to protect the decals.

**LAUNCHING COMPONENTS**

To launch your rocket you will need the following items:

- An Estes model rocket launching system.
- Parachute recovery wadding (Estes Cat. No. 2274).
- Estes A8-3, B4-4, B6-4, or C6-5 model rocket engines. (Use a A8-3 engine for first flight.)

Be sure to follow the HIAA-NAR\* Model Rocketry Safety Code when carrying out your model rocket activities.

\*HIAA-NAR - Hobby Industry Association of America National Association of Rocketry.

**COUNTDOWN CHECKLIST**

**T-14** Pack 5 or 6 squares of loosely crumpled recovery wadding into the body tube.



**T-13** Fold the parachute into a triangular shape. Fold chute tightly as shown and wrap shroud lines around it. If chute is too large, unroll it and repack until it slides easily into rocket. A fit that is too tight may prevent parachute from ejecting properly.

**NOTE: DO NOT** pack parachute until you are actually ready to launch. For maximum parachute reliability, lightly dust the chute with ordinary talcum powder before each flight, especially in cold weather.

**T-12** Pack shock cord neatly into rocket, then slide nose cone into place. Nose cone should separate easily from rocket body tube, but should not be extremely loose. If it is too tight, sand inside of body tube end and shoulder of nose cone with extra fine sandpaper.

If nose cone is too loose, add a wrapping of transparent tape or masking tape to the shoulder of the nose cone.

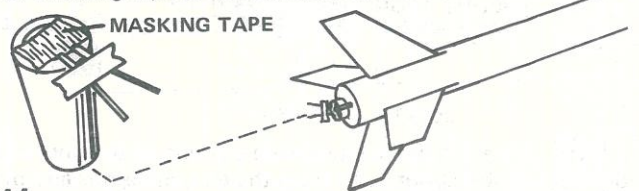

**T-11** Select an engine and install all igniter as directed in the engine instructions. Engines recommended for use with this model rocket are the A8-3, B4-4, B6-4, or C6-5 made by Estes.

Use an A8-3 engine for your first flight.

**T-10** Insert engine into rocket. Engine hook must latch securely over end of engine.



Due to the rocket's length, additional launch pad stability is required for safety. Weigh down or secure your pad with bricks or coat hanger stakes using the following procedure.

Cut three hold-down stakes from coat hangers as shown. Adjust the launch pad on level ground. Pass the stake hooks through the launch pad legs, then push the stakes firmly into the ground. Check to be sure the launch pad is held down securely before proceeding.

**T-9** Disarm the launch panel--remove safety key.

**T-8** Place rocket on launch pad, making sure rocket slides freely on launch rod. Clean the micro-clips and attach them to the igniter.

**T-7** Clear the launch area, alert the recovery crew and trackers. Check for low flying aircraft and unauthorized persons in the recovery area.

**T-6** Arm the launch panel--insert safety key.

**-5-4-3-2-1-LAUNCH!!**

**MISFIRE PROCEDURE**

Occasionally the igniter will heat and burn into two pieces without igniting the engine. This is almost always caused by a failure to install it correctly. Disarm the launch panel, remove the model, clean the igniter residue from the nozzle, and install a new igniter. Follow the launching procedure again.