

COUNTDOWN AND LAUNCH

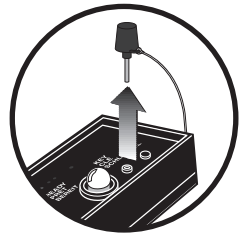

KEY ALWAYS OUT UNTIL FINAL COUNTDOWN!

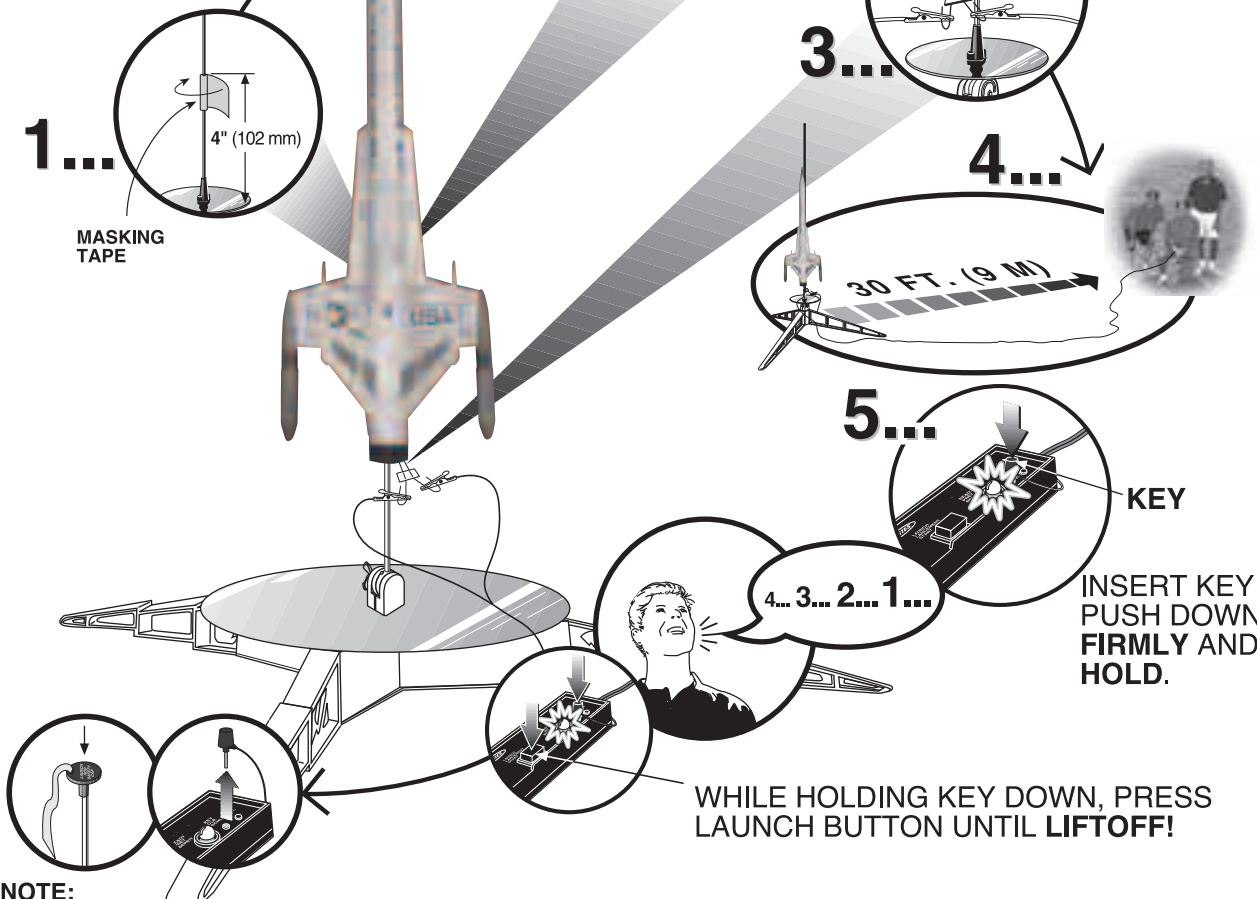

ESTES LAUNCH SUPPLIES

- (Sold Separately)
- E Launch Pad (Requires 3/16" [5 mm] Maxi™ Rod - sold separately).
 - E Launch Controller
 - Recovery Wadding
 - Igniters and Igniter Plugs (included with Estes engines)
 - **Estes Engine: E9-4**

IMPORTANT NOTE: IF YOUR FINISHED INTERCEPTOR™ E MODEL ROCKET WEIGHS MORE THAN 16 oz. (453 g) WITH ENGINE INSERTED YOU MUST NOTIFY AND PERHAPS OBTAIN AUTHORIZATION FROM THE FEDERAL AVIATION ADMINISTRATION (FAA). CHECK YOUR TELEPHONE DIRECTORY FOR THE OFFICE NEAREST YOU OR CONTACT ESTES INDUSTRIES FOR FURTHER INFORMATION.

PRECAUTIONS



NAR Safety Code



NO DRY GRASS OR WEEDS

PRE-LAUNCH CHECK

For safety, never launch a damaged rocket. Check the rocket's body, nose cone and fins. Also, check the engine mount, recovery system and launch lug(s). Repair any damage before launching the rocket.

FLYING YOUR ROCKET

Choose a large field (500 ft. [152 m] square) free of dry weeds and brown grass. The larger the launch area, the better your chance of recovering your rocket. Football fields and playgrounds are great. Launch only with little or no wind and good visibility.

Always follow the National Association of Rocketry (NAR) SAFETY CODE.

MISFIRES

TAKE THE KEY OUT OF THE CONTROLLER. WAIT ONE MINUTE BEFORE GOING NEAR THE ROCKET! Disconnect the igniter clips and remove the engine. Take the plug and igniter out of the engine. If the igniter has burned, it worked but did not ignite the engine because it was not touching the propellant inside the engine. Put a new igniter all the way inside the engine without bending it. Push the plug in place. Repeat the steps under Countdown and Launch.



www.estesrockets.com

ESTES-COX CORP.
1295 H Street, PO Box 227
Penrose, CO 81240-0227
PRINTED IN CHINA

INTERCEPTOR™ E

FLYING MODEL ROCKET KIT INSTRUCTIONS
KEEP FOR FUTURE REFERENCE

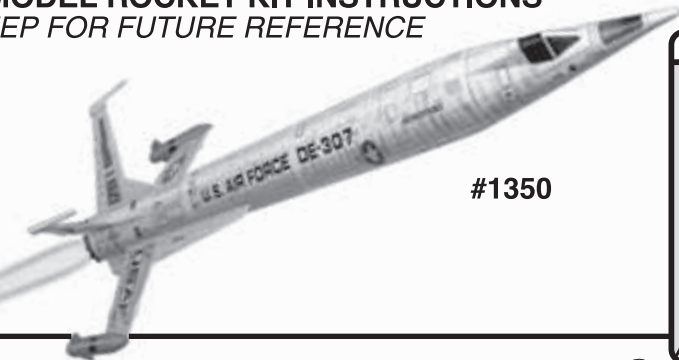

#1350

HELPFUL HINT: IF NOSE CONE FIT IS...

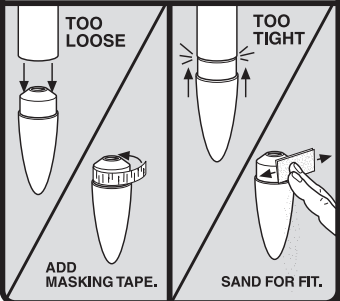

PARTS Locate the parts shown below and lay them out on the table in front of you. DO NOT USE THIS DRAWING TO ASSEMBLE YOUR ROCKET.

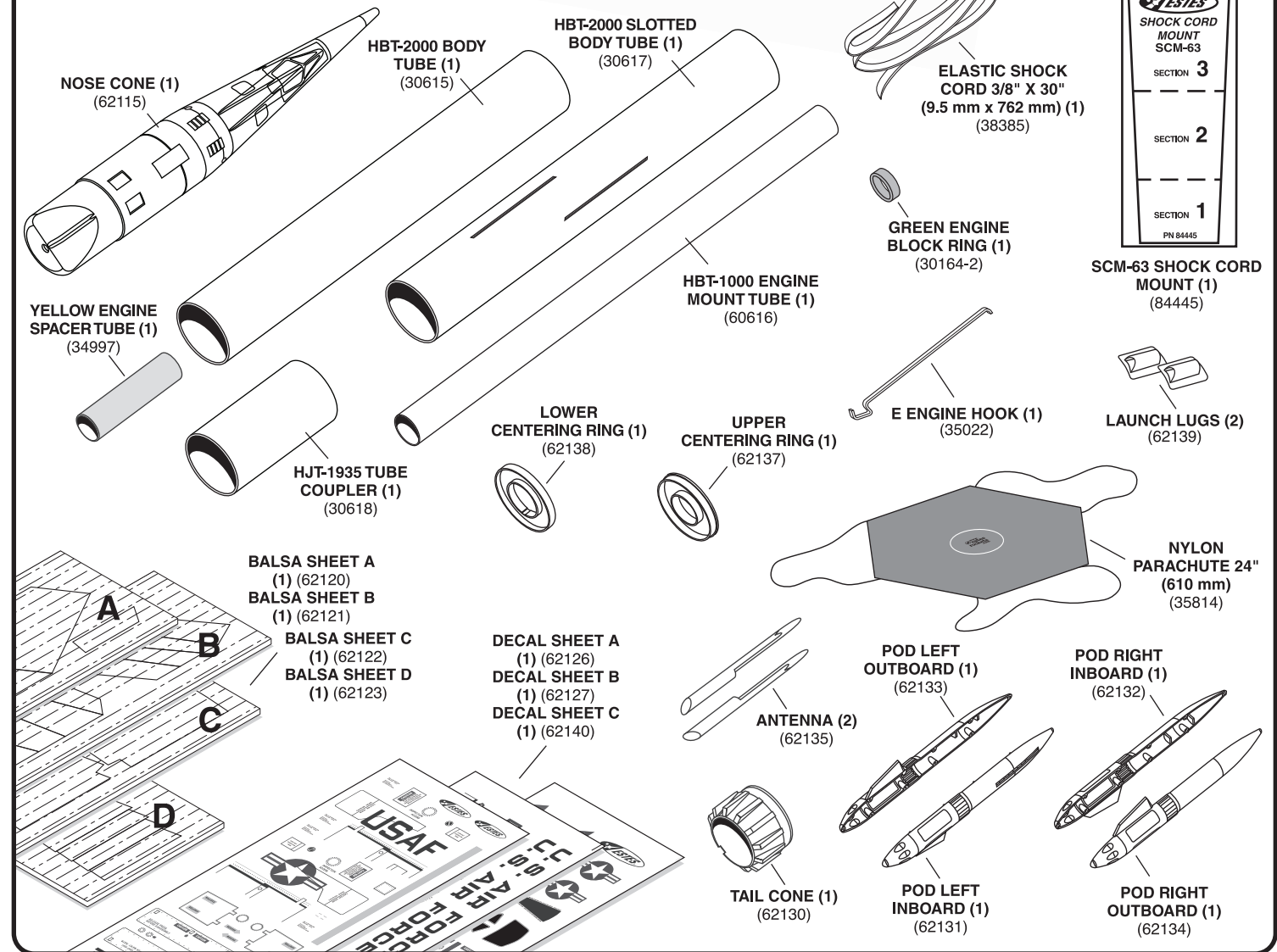

SUPPLIES In addition to the parts included in the kit you will also need:

NOTE ON GLUE: We show the use of epoxy in the construction of this kit because it is a strong adhesive. Epoxy is a 2 part adhesive and needs to be mixed before use. You can use your favorite adhesive(s) to construct this kit, but use only high strength adhesive(s) in the areas where epoxy is being shown.



BODY TUBE MARKING GUIDE (Make a copy if you want to keep instructions.)

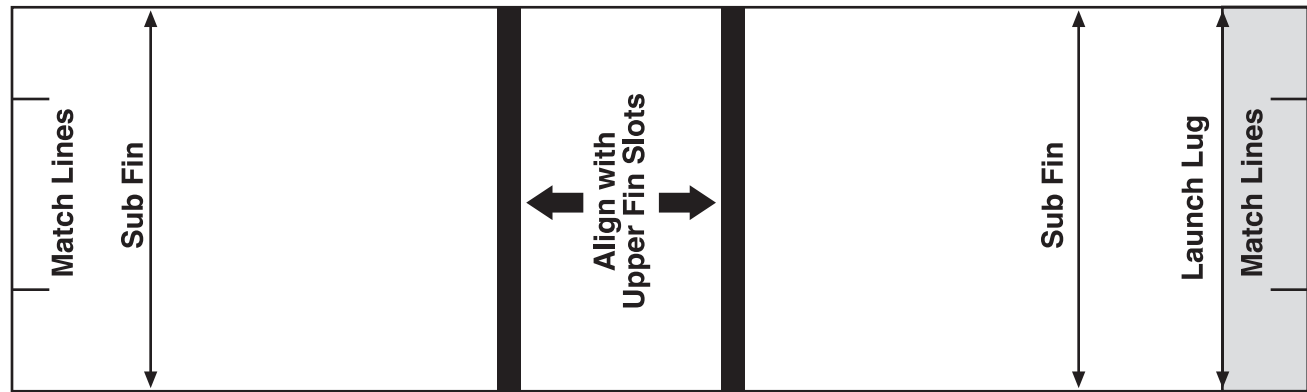

1. ASSEMBLE ENGINE MOUNT

A. Use a pencil to mark the engine mount tube and yellow spacer tube as shown.

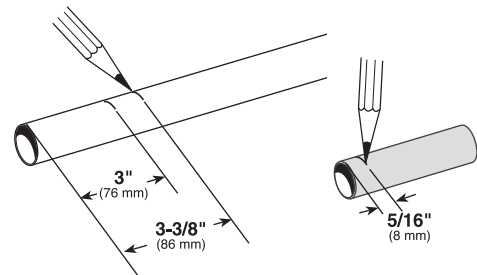

B. Using a scrap piece of balsa, smear glue 3 - 1/4" (83 mm) inside engine mount tube.

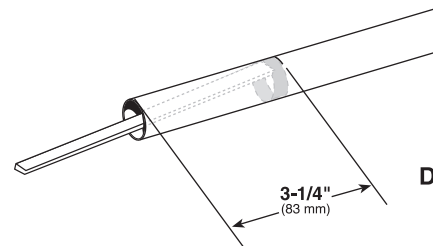

C. Use the yellow spacer tube to push the green engine block into the engine mount tube up to the 5/16" (8 mm) mark on the spacer tube.

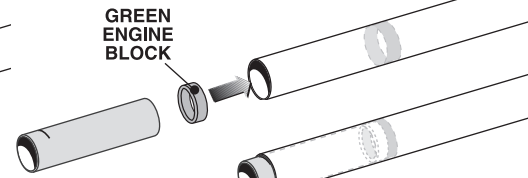

D. Immediately remove spacer tube from engine mount tube.

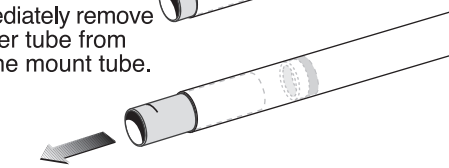

E. Make an 1/8" (3 mm) slit in the engine mount tube at the 3 - 3/8" (86 mm) mark. Insert engine hook into slit.

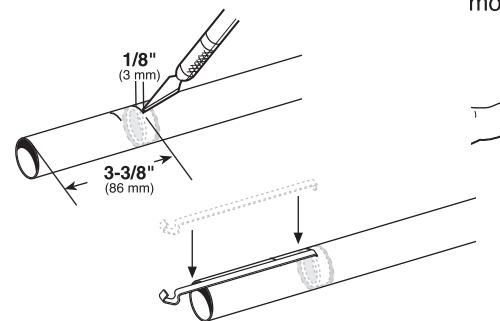

F. Scuff the inside surface of the lower centering ring with 220 sandpaper. Mix a small amount of 5 minute epoxy and apply around the engine mount tube below the 3" (76 mm) mark.

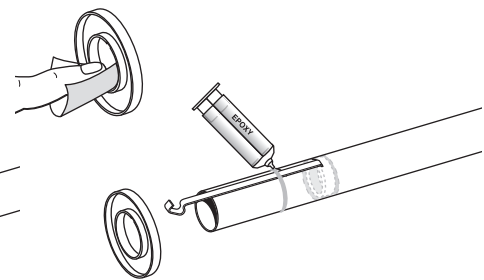

F1. With the notch over the engine hook, slide the lower centering ring onto the engine mount tube to the 3" (76 mm) mark as shown. Let epoxy set.

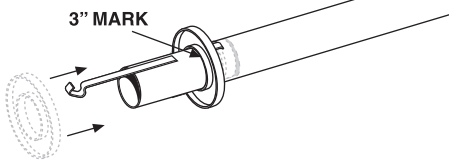

2. MARK BODY TUBE

A. Cut out the body tube marking guide.

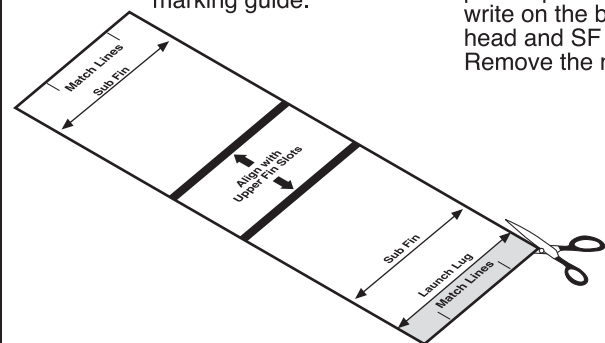

B. Tape guide around slotted body tube aligning the upper fin slots marks on the guide with the upper fin slots cut into the body tube. At each arrow head place a pencil mark on the body tube. For reference, write on the body tube LL at the launch lug arrow head and SF at the sub fin arrow heads. Remove the marking guide.

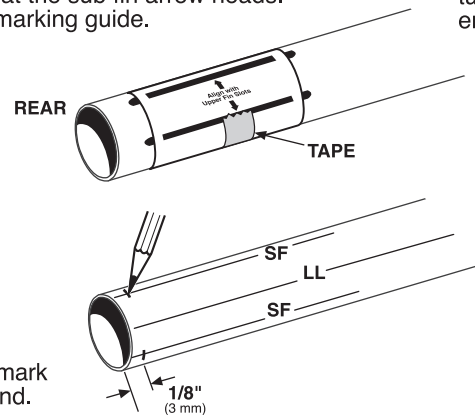

C. Hold the body tube against a door frame. Align, and connect each pair of pencil marks on the body tube with a straight line the following lengths: Launch Lug line the full length of the tube. Sub Fin lines 5" (127 mm) from the end of the tube.

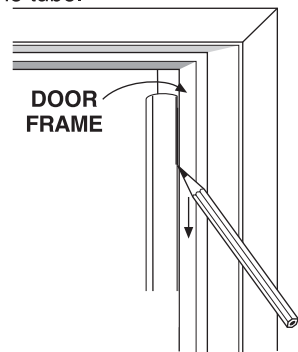

D. On the two sub fin lines, make a pencil mark on the body tube 1/8" (3 mm) from the end.

14. ATTACH PARACHUTE AND NOSECONE

A. Clean the eye of the nose cone.

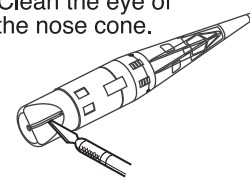

B. Tie shock cord to nose cone.

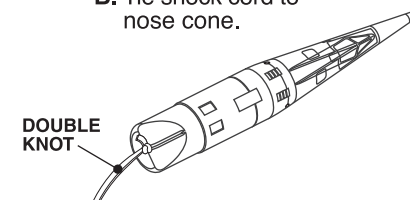

C. Form loop with parachute shroud lines.

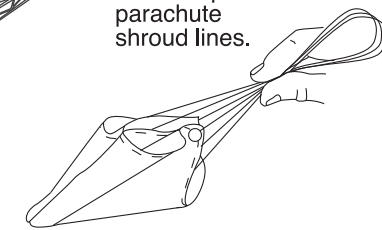

D. Pass loop through eye of nose cone.

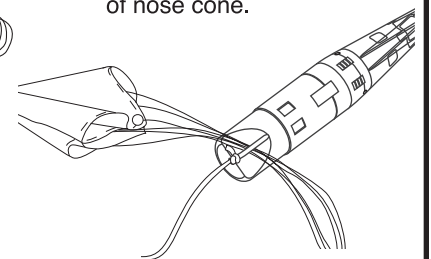

CAUTION: DO NOT CUT EYE OF NOSE CONE OFF!

E. Pass parachute through loop of shroud lines.

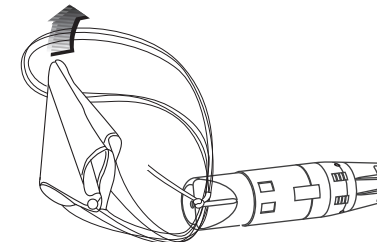

F. Pull tight.

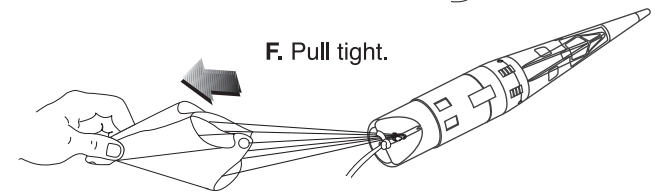

15. PREPARE RECOVERY SYSTEM

A. Pull shock cord taut when inserting wadding.

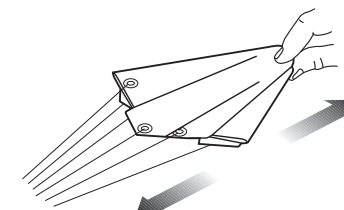

B. Insert 10-12 squares of loosely crumpled recovery wadding into rocket. Push below shock cord attachment

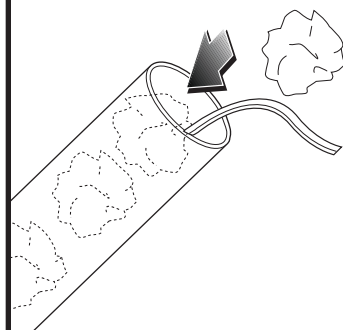

C. Spike parachute.

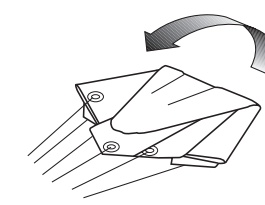

E. Roll.

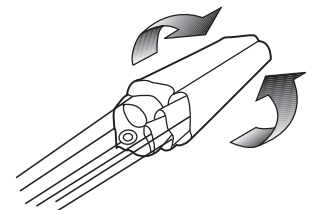

D. Fold.

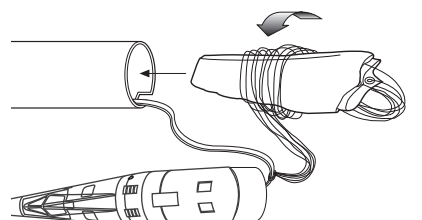

F. Wrap shroud lines loosely. Insert parachute, shock cord and nose cone into body tube.

NOTE: Only Estes wadding (302274) recommended.

IMPORTANT: Wadding must be in place and slide freely for recovery system to work properly.

16. PREPARE ENGINE

WARNING: FLAMMABLE

To avoid serious injury, read instructions & NAR Safety Code included with engines. **PREPARE ENGINE ONLY WHEN YOU ARE OUTSIDE AT THE LAUNCH SITE PREPARING TO LAUNCH!** If you do not use your prepared engine, remove the igniter before storing engine.

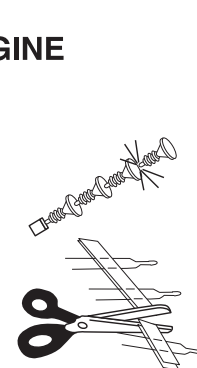

A. Separate igniter and plug.

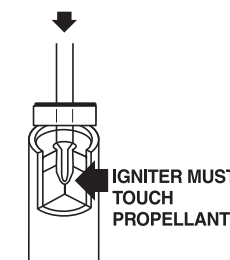

B. Insert igniter.



C. Insert plug.



D. Push down.

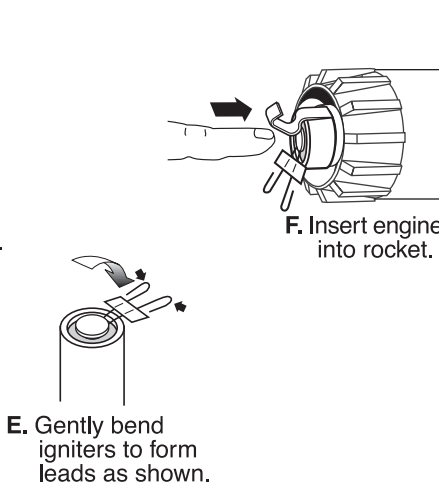

E. Gently bend igniter leads to form leads as shown.

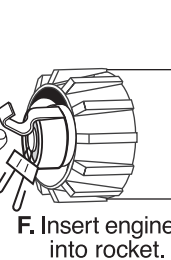

F. Insert engine into rocket.

13. PAINT & FINISH THE ROCKET

- A. To protect the inside of the rocket from paint overspray, mask the open end of the body tube and the engine mount.
- B. Apply white primer to all the balsa surfaces. Let primer dry, then sand smooth using 320 grit sand paper. Repeat until balsa grain has been filled.
- C. Apply white paint to the entire rocket. Let paint dry.
- D. Mask the wings around the wing pods and paint the wing pods Fluorescent Orange. Let paint dry and remove mask.
- E. Mask the rear body tube and paint the tail cone Black. Let paint dry and remove mask.
- F. Mask the shoulder of the nose cone. Apply white paint to the nose cone. Let paint dry and remove mask.

FINISHING NOTES:

- 1. DO NOT EXCEED 15 oz. (425 g) TOTAL FINISHED WEIGHT.
- 2. YOU CAN ADD HIGHLIGHTS TO YOUR ROCKET WITH PAINT DETAILS OF YOUR OWN AS WE DID IN THE IMAGES SHOWN.
- 3. ALWAYS REMOVE NOSE CONE AND PAINT SEPARATELY. DO NOT PAINT NOSE CONE SHOULDER.
- 4. IF YOUR FINISHED INTERCEPTOR™ E MODEL ROCKET WEIGHS MORE THAN 16 oz. (454 g) WITH ENGINE INSERTED YOU MUST NOTIFY AND PERHAPS OBTAIN AUTHORIZATION FROM THE FEDERAL AVIATION ADMINISTRATION (FAA). CHECK YOUR TELEPHONE DIRECTORY FOR THE OFFICE NEAREST YOU OR CONTACT ESTES INDUSTRIES FOR FURTHER INFORMATION.

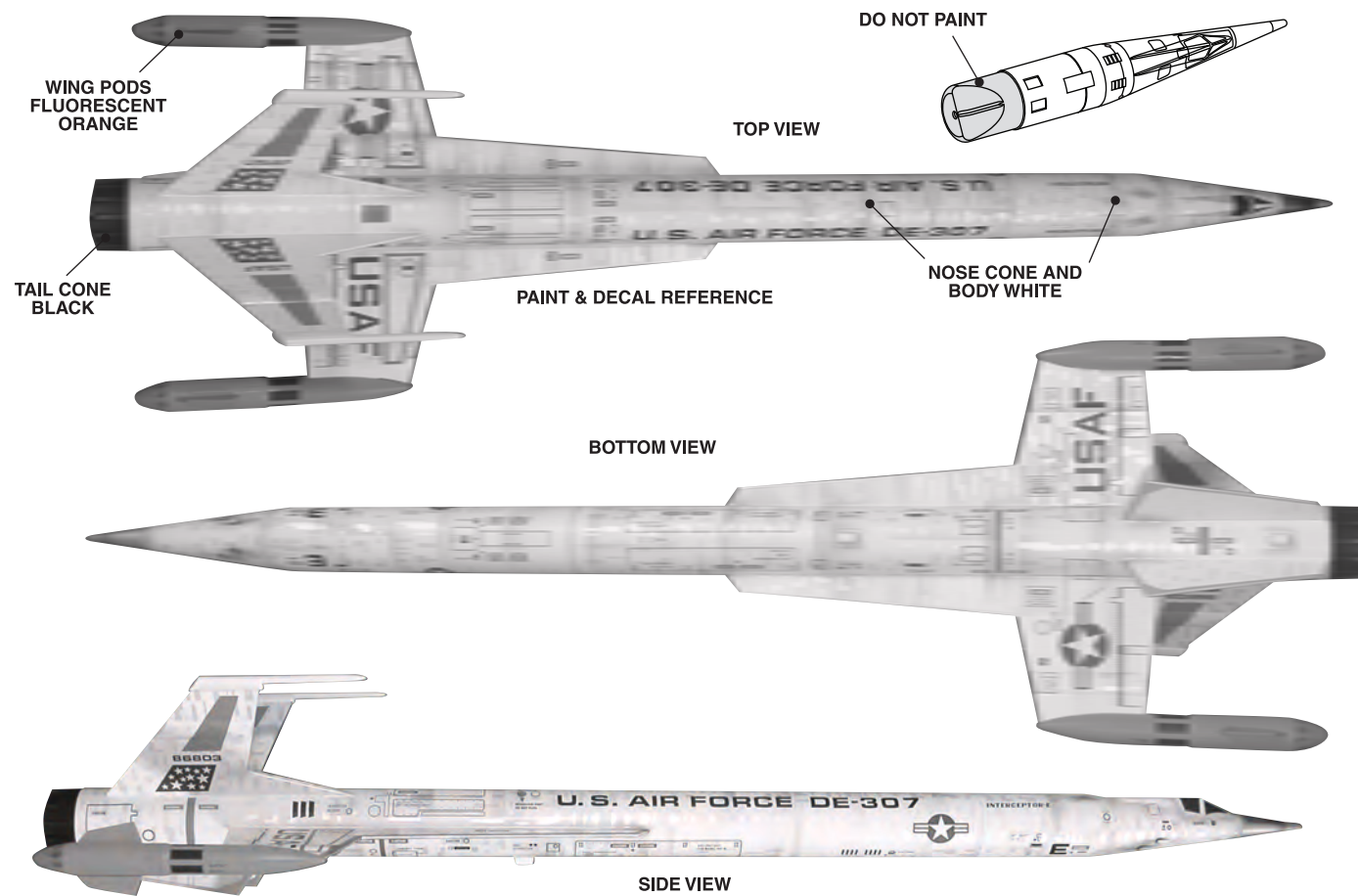

APPLYING THE DECALS:

Because the Interceptor™ E decals are applied in large sections, follow these steps (See DIAGRAM F):

- 1) Apply the decals to the bottom of the rocket, then the sides, then the top & nose cone of the rocket for best alignment.
- 2) Cut out the desired decal from the decal sheet one at a time.
- 3) Wet the surface of the rocket where the decal is to be applied with a soft 3/4" - 1" (19 mm - 25 mm) wide brush.
- 4) Place decal in water long enough for it to begin sliding from the sheet then remove from water.
- 5) Slide decal from backing paper onto rocket surface.
- 6) Position and smooth out bubbles using the wet brush.
- 7) Blot with a damp cloth or sponge to remove excess water and blow dry.
- 8) Continue applying rest of the decals.
- 9) After all decals have been applied and completely dried, clear coat the entire rocket. Let clear coat dry completely.

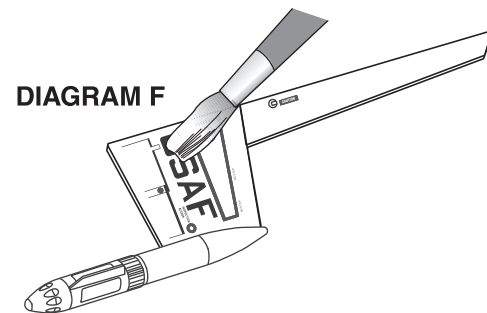

3. INSTALL ENGINE MOUNT AND TAIL CONE

- A. Make a pencil mark on the tube coupler 2" (51 mm) from either end.

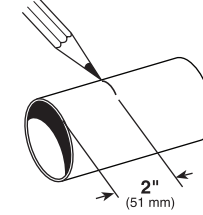

- B. Smear carpenter's glue inside the forward end of the slotted body tube. In one smooth motion insert the tube coupler into the body tube to the 2" (51 mm) mark. Let glue dry.

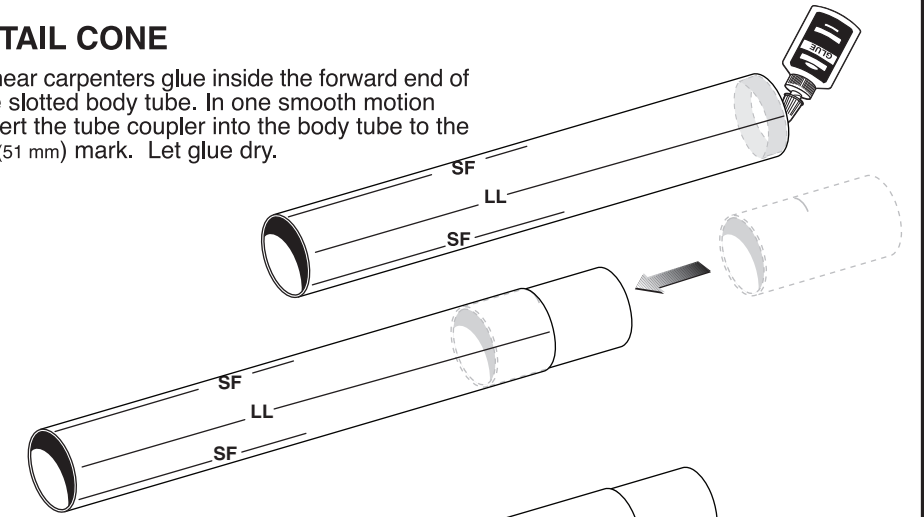

- C. Scuff the outer edge of the lower centering ring with 220 sandpaper. Insert the engine mount into the slotted body tube until the front end of the motor mount sticks out approximately 3" (76 mm) from the forward end of the tube coupler. Do not glue in place.

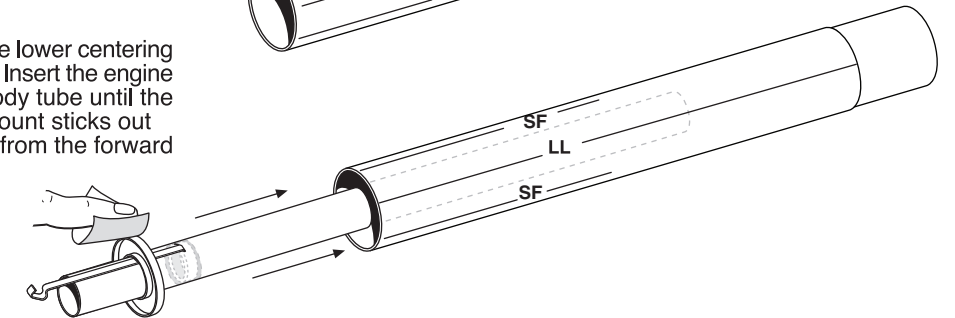

- D. Scuff the inside and outside flanges of the upper centering ring. Mix a small amount of 5 minute epoxy and apply a ring inside the front end of the engine mount. Push the upper centering ring into the engine mount tube. Let epoxy set.

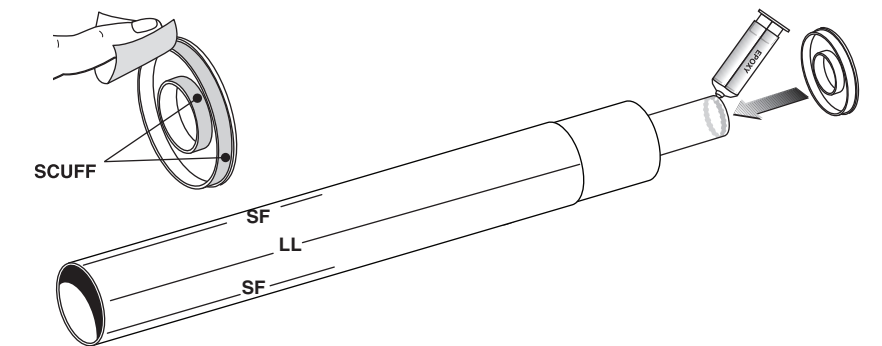

- E. Mix a small amount of 15 minute epoxy and using a scrap balsa stick, apply a ring of epoxy inside the slotted body tube 2-1/4" (57 mm) from the rear end. Then apply a ring of epoxy inside the forward end of the tube coupler. Push the engine mount assembly back into the body tube coupler assembly, twisting it back and forth a little to distribute the epoxy around the rings and align the engine hook with the launch lug line. Let epoxy set.

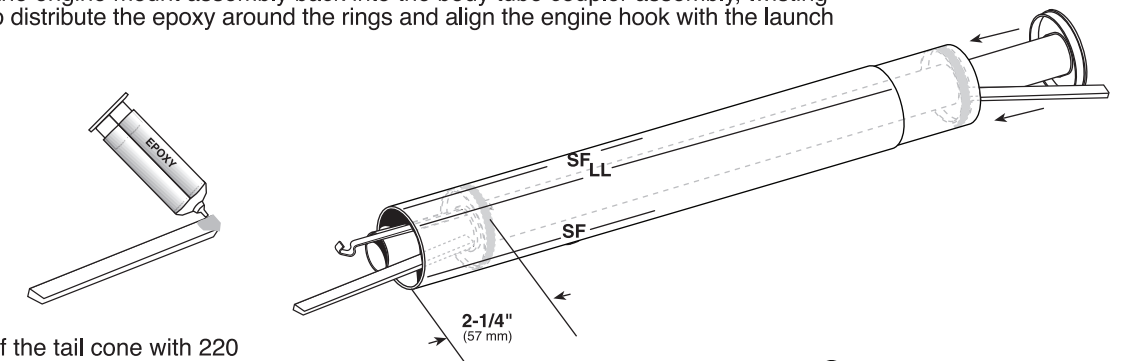

- F. Scuff the outside flange of the tail cone with 220 sandpaper. Mix a small amount of 5 minute epoxy and apply a ring inside the slotted body tube end. Insert the tail cone into the body tube. Let epoxy set.

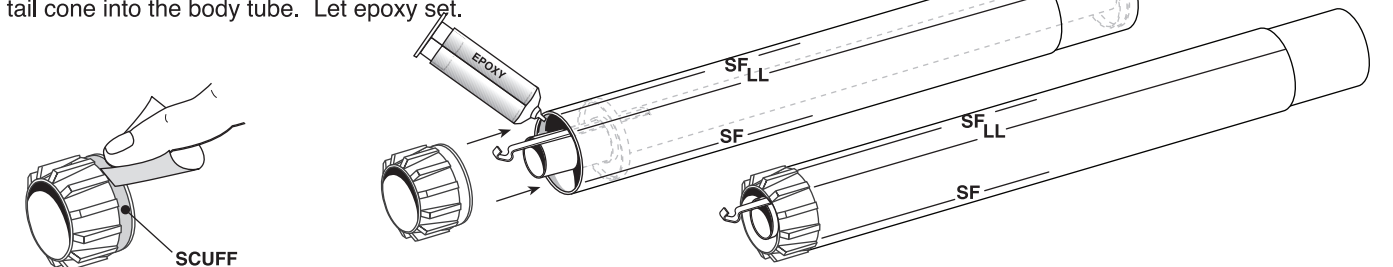

4. ASSEMBLE BODY TUBE

A. Smear carpenter's glue inside one end of the upper body tube. Slide the body tube onto the coupler until it contacts the slotted body tube. Let glue dry.

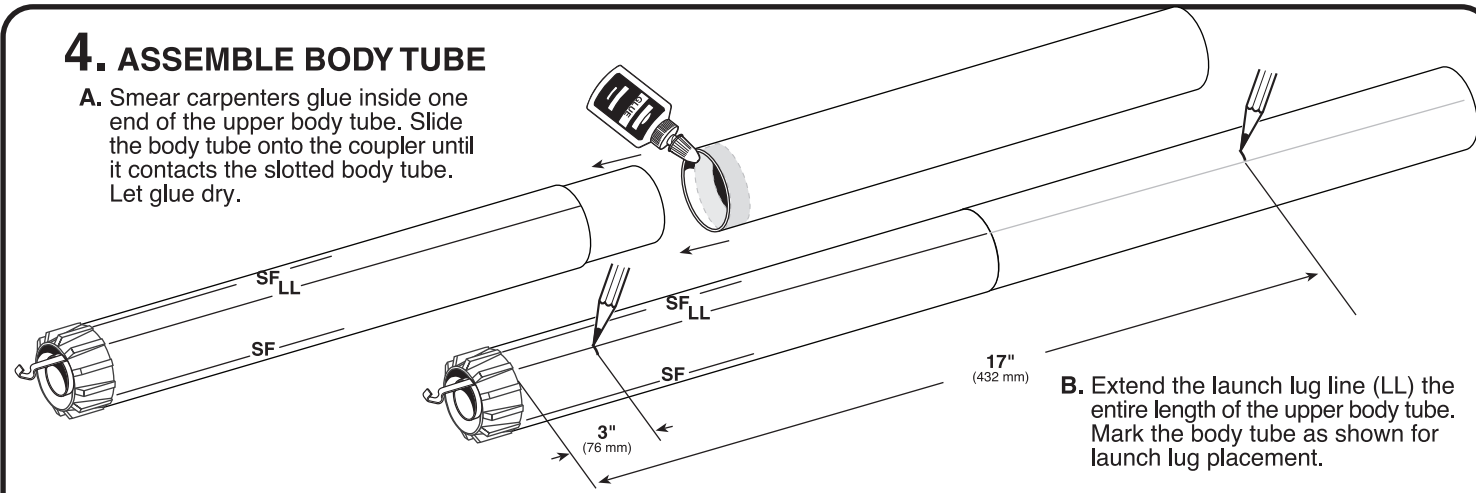

B. Extend the launch lug line (LL) the entire length of the upper body tube. Mark the body tube as shown for launch lug placement.

5. PREPARE ALL Balsa PARTS

A. Sand all the balsa sheets with fine (220 grit) sandpaper, both sides.

B. Cut balsa parts free with hobby knife.

C. Stack like fins together and sand edges.

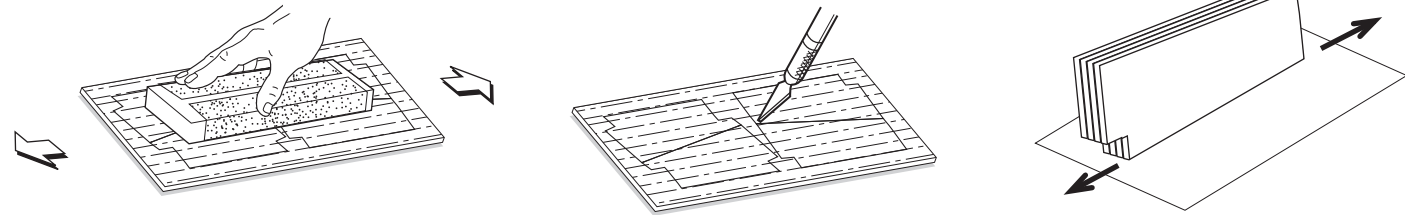

6. ASSEMBLE AND ATTACH SUB FINS

A. Tape a piece of Wax Paper onto a flat, smooth surface. Position the sub fin pieces as shown. Apply glue to one edge of a fin piece and attach to the other. Use a straight edge (or ruler) to align the two pieces straight across the bottom. Cover with waxpaper and weigh the assembly down flat while the glue dries completely. Repeat for the second sub fin assembly.

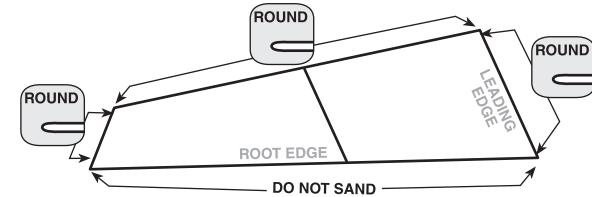

B. Using 220 sandpaper, block sand the sub fin assemblies smooth. Sand the edges round as shown.

DIAGRAM A

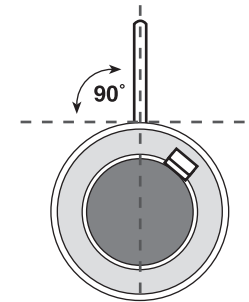
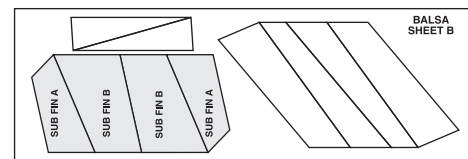
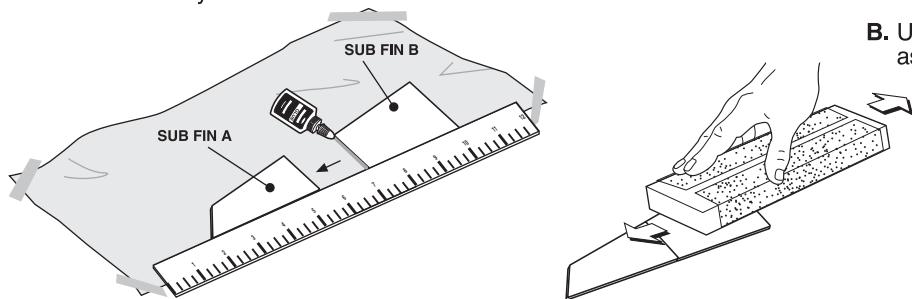
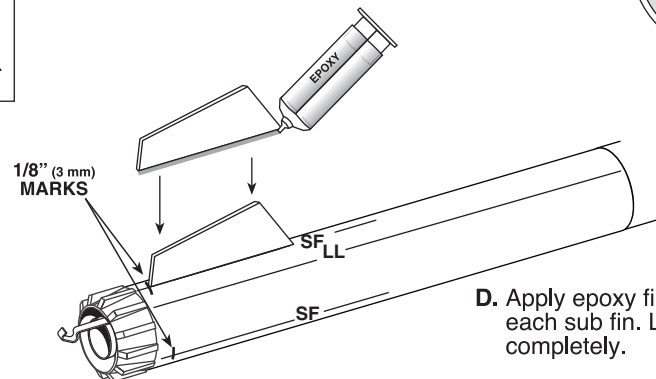

DIAGRAM B



C. Mix a small amount of 15 minute epoxy and apply along the root edge of the Sub Fin as shown. Align and center the Sub Fin on the 'SF' line 1/8" (3 mm) from end of slotted body tube. Position Sub Fin perpendicular (90°) to body tube as shown in DIAGRAM A. Smooth any excess epoxy between fin and body tube with your finger. Repeat for the other Sub Fin. Before the epoxy sets, check the alignment of the sub fin as per DIAGRAM B. Let epoxy set completely.



D. Apply epoxy fillets to both sides of each sub fin. Let epoxy set completely.

11. ATTACH WING PODS AND FIN ANTENNAS

A. Apply plastic cement to one half of the wing pod as shown. Align and attach to other half. Repeat for other wing pod. Let glue dry.

B. Trial fit the pods to the wings. The pods are designed so that their fins align parallel to the vertical center line of the rocket (refer to DIAGRAM E). If the pod fins are not parallel switch the pod to the opposite wing. Mix a small amount of 15 minute epoxy and slide the Wing Pod assembly onto the wing as shown. Tape in place while epoxy sets. Repeat for other pod.

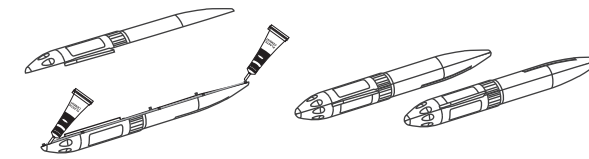

C. Mix a small amount of 15 minute epoxy and apply a fillet around each pod where it joins the wing. Smooth with your finger and let set.

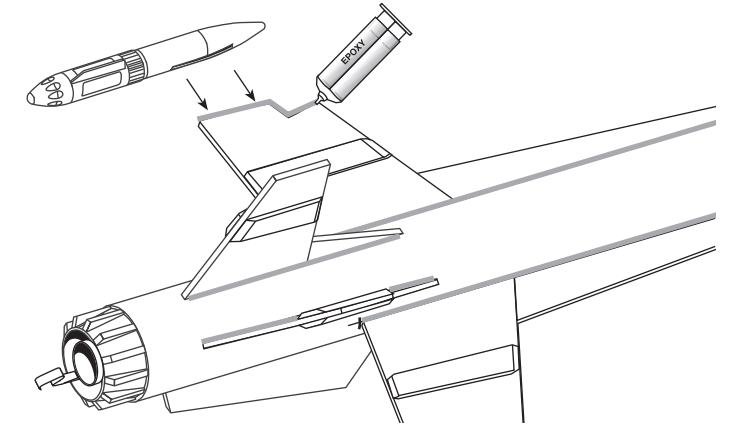
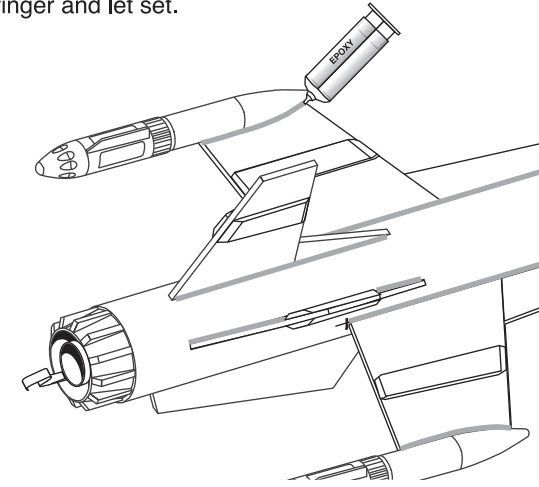

D. Scuff the insides of the slot in each antenna. Mix a small amount of 15 minute epoxy and apply to the top of the upper fins as shown. Attach an antenna to each upper fin. Wipe any excess epoxy from joint. Let epoxy set.

E. Scuff the bottom side of each launch lug with 220 sandpaper. Mix a small amount of 15 minute epoxy and smear onto the bottom of each launch lug. Attach one launch lug at the 3" (76 mm) mark and the other at the 17" (432 mm) mark along the launch lug line. A launch rod may be inserted to assure proper alignment. Wipe any excess epoxy away and let epoxy set completely.

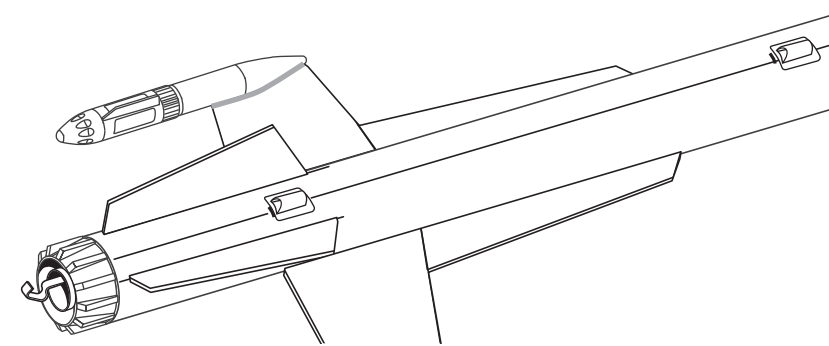
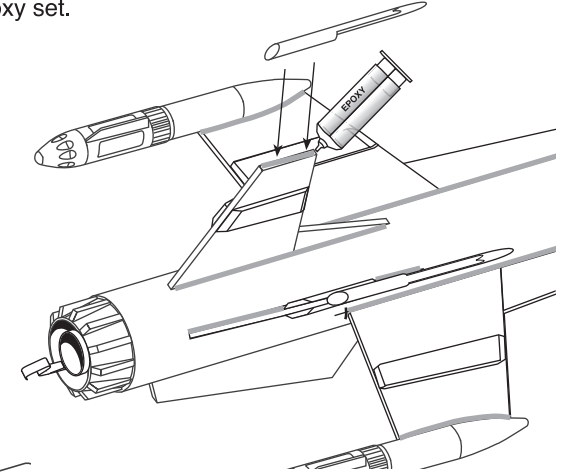
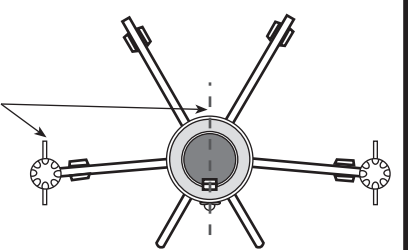

DIAGRAM E

FIN PARALLEL WITH ROCKET CENTER LINE



12. INSTALL SHOCK CORD

A. Cut out shock cord mount.

B. Fold.

C. Apply glue. Fold forward.

D. Apply glue. Fold forward.

E. Squeeze tightly and hold for one minute.

F. Glue mount 2" (51 mm) inside front of body tube. Hold until glue sets. Let dry.

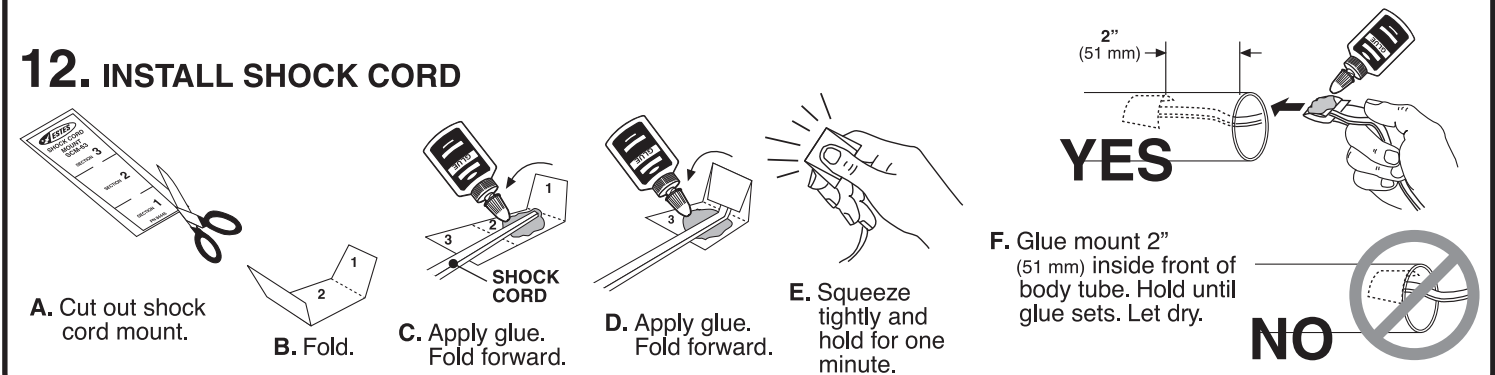

10. ATTACH UPPER FINS

A. One upper fin assembly at a time, mix a small amount of 15 minute epoxy and apply it to the root edge of the upper fin as shown. Align the tab of the upper fin with the slot in the body tube and attach upper fin perpendicular (90°) to body tube as shown in DIAGRAM A before. Smooth any excess epoxy between upper fin and body tube with your finger. Before the epoxy sets, check the alignment of the upper fin as per DIAGRAM D. Repeat for the other upper fin.

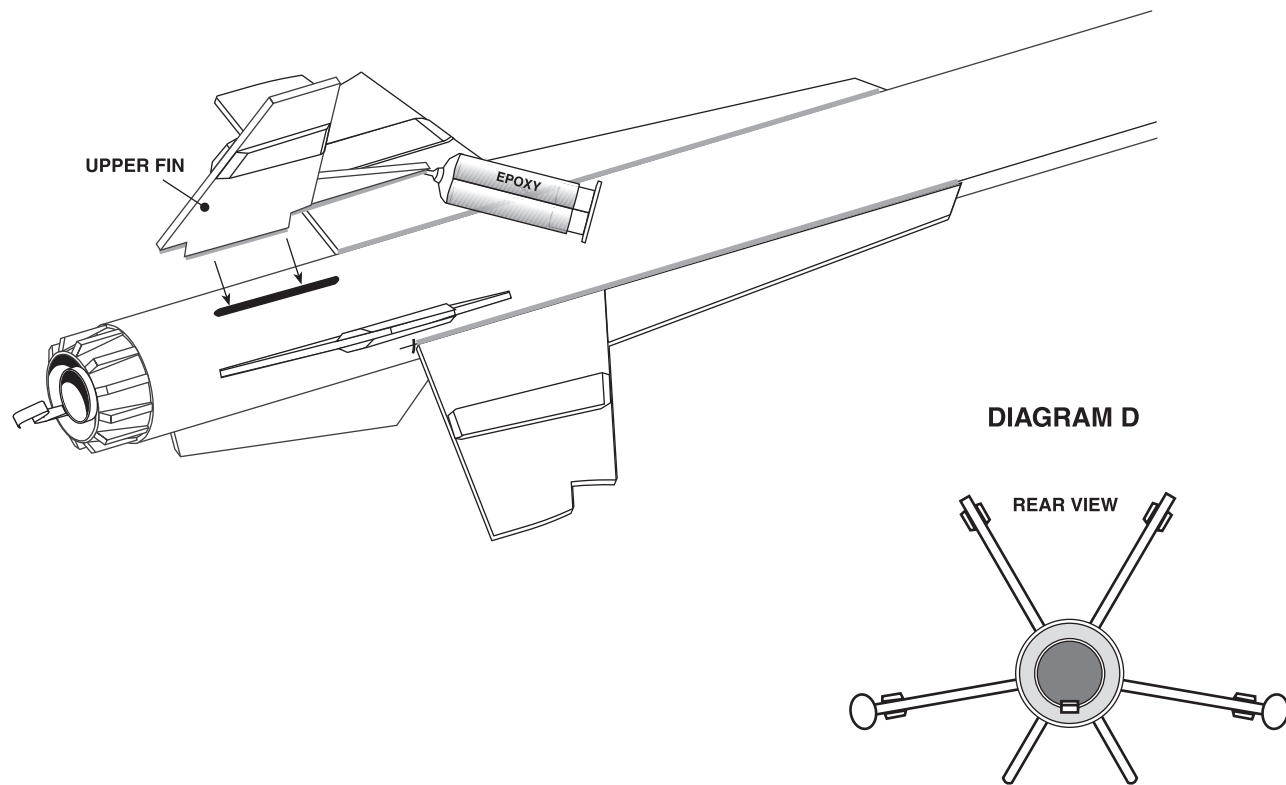

B. Apply epoxy fillets to both sides of each upper fin tube joint. Let epoxy set completely.

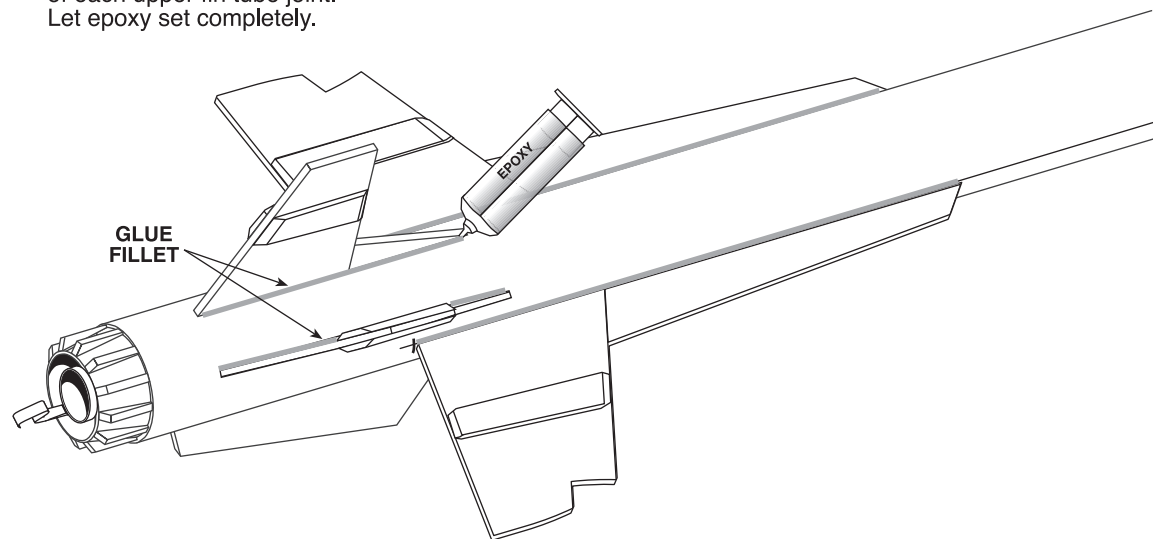

7. ASSEMBLE THE WINGS

A. On the piece of Wax Paper taped to a flat, smooth surface, position the wing pieces as shown. Apply glue to one edge of a wing piece and attach to the other. Let glue dry. Repeat for other wing.

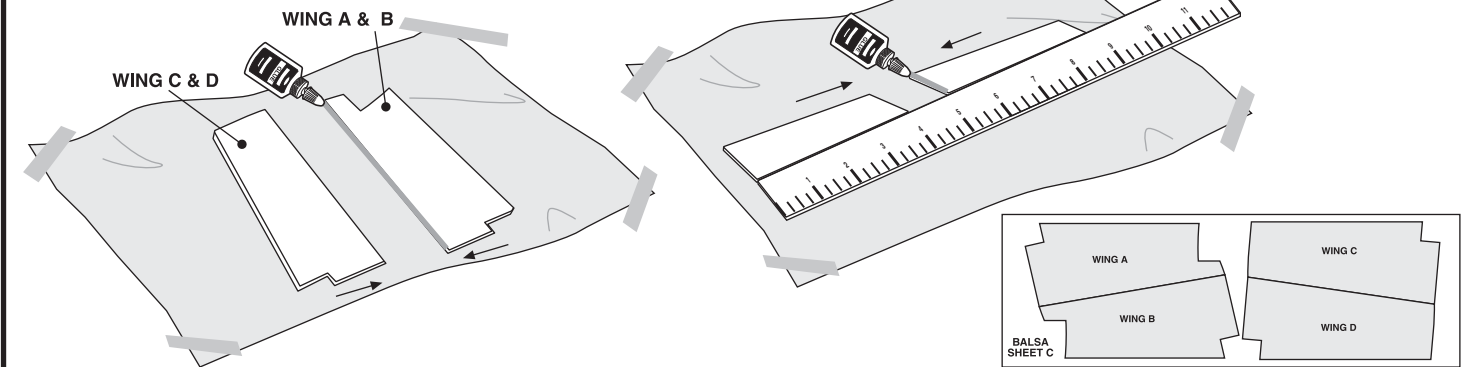

B. Apply glue to the dorsal fin joint. Use a straight edge (or ruler) to align the dorsal fin straight across the root edge as shown. Let glue dry and repeat for other dorsal fin.

C. Apply glue to the rear of the dorsal fin. Use a straight edge (or ruler) to align the dorsal fin with the wing as shown. Cover with wax paper and weigh the assembly down flat while the glue dries completely. Repeat for the second wing assembly.

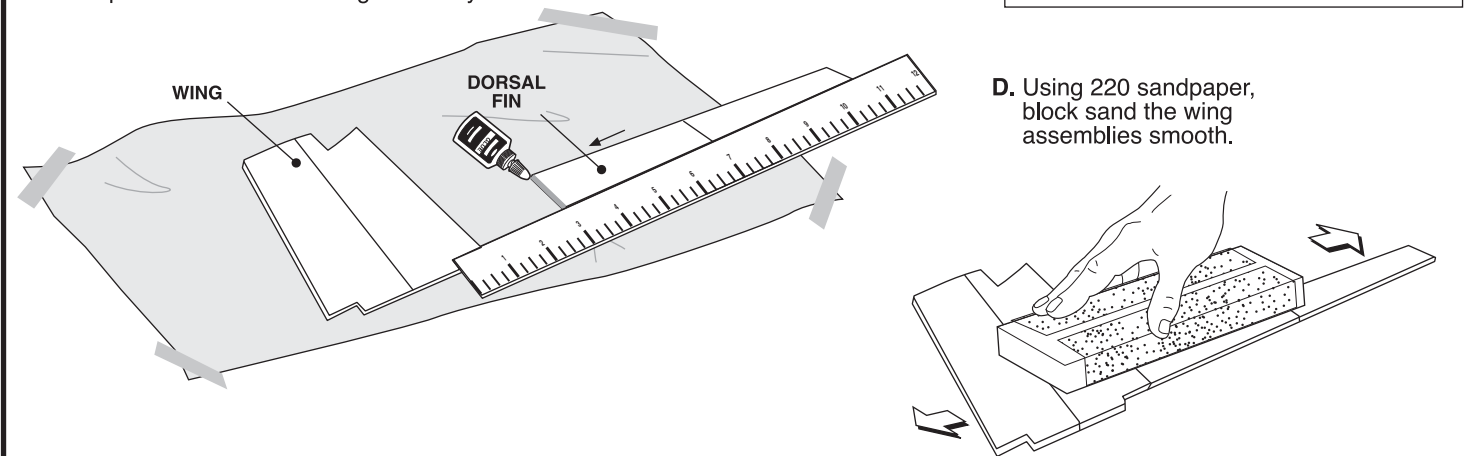

E. Using 220 sandpaper bevel the ends and round off the edges of the 4 wing supports as shown. Apply glue to the flat side of each wing support and apply to each side of the wing where shown.

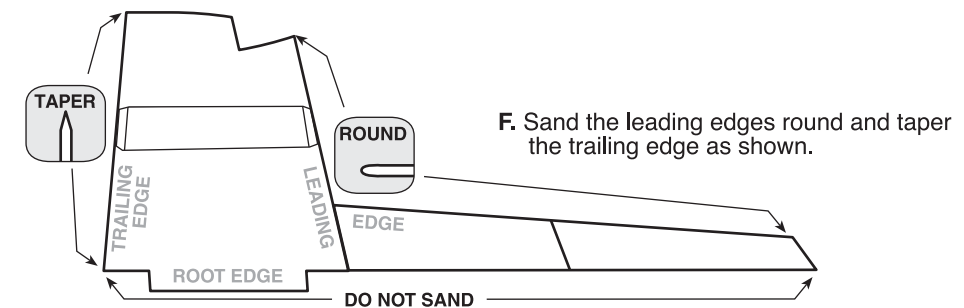
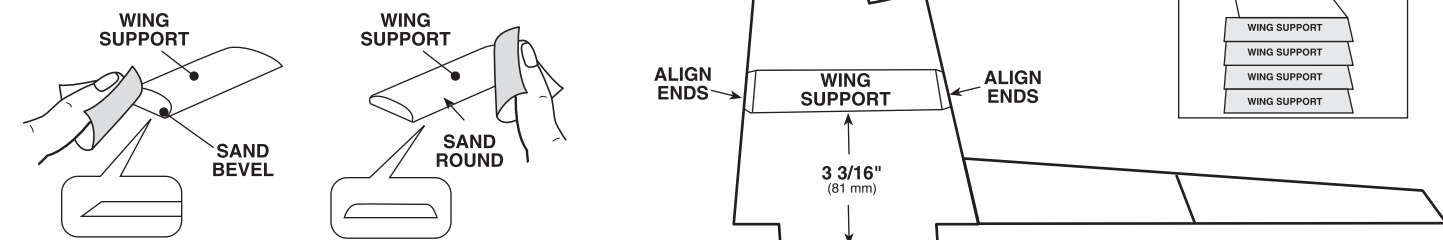

F. Sand the leading edges round and taper the trailing edge as shown.

8. ATTACH THE WINGS

A. One wing assembly at a time, mix a small amount of 15 minute epoxy and apply it to the root edge of the wing as shown. Align the tab of the wing with a forward slot in the body tube and attach wing perpendicular (90°) to body tube as shown in DIAGRAM A before. Smooth any excess epoxy between wing and body tube with your finger. Repeat for the other wing. Before the epoxy sets, check the alignment of the wings as per DIAGRAM C.

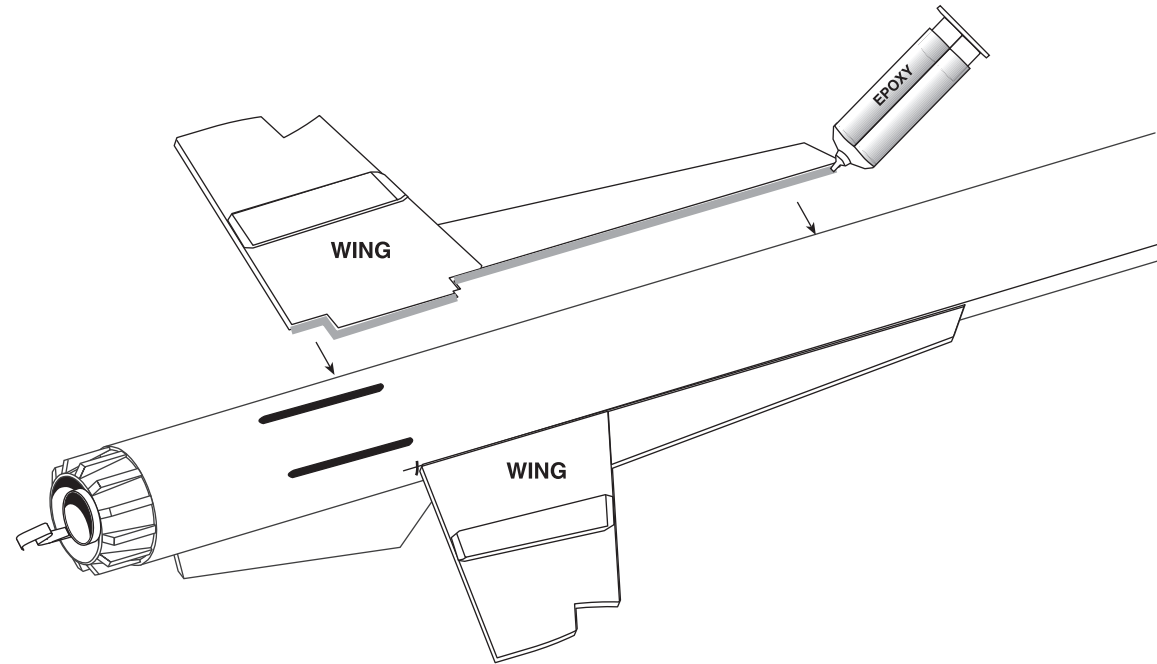

B. Apply 15 minute epoxy fillets to both sides of each wing tube joint. Smooth with your finger. Let epoxy set completely.

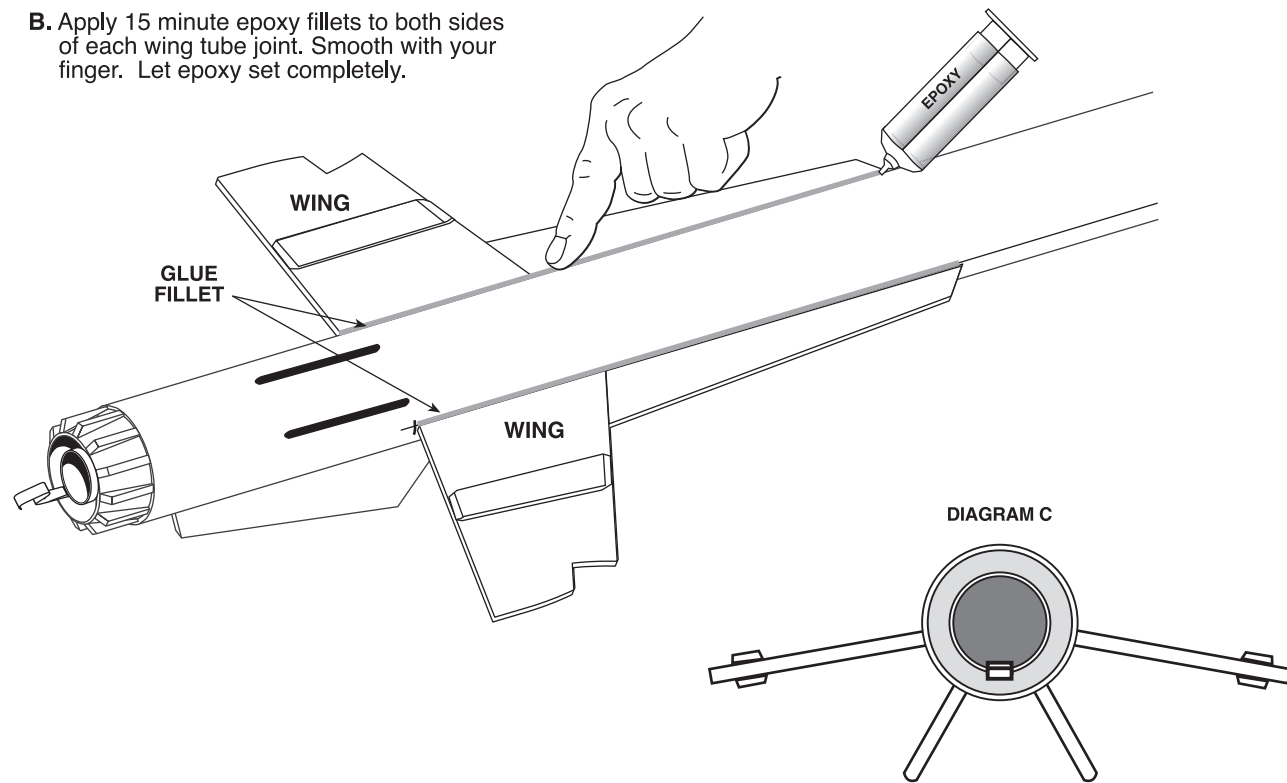

9. ASSEMBLE UPPER FINS

A. Using a straight edge (or ruler) as a guide, draw a pencil line across the tab even with the root edge of the upper fin as shown.

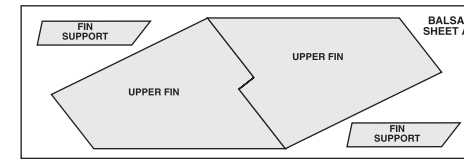
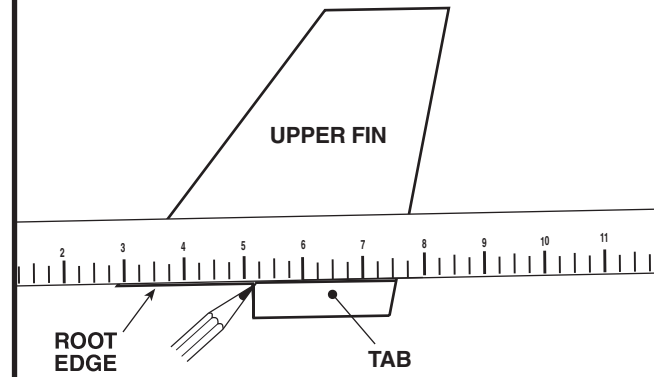

B. On a piece of wax paper apply glue to the end of the dorsal fin and attach to the upper fin as shown. Cover with wax paper and weigh the assembly down flat while the glue dries completely. Repeat for the second upper fin assembly.

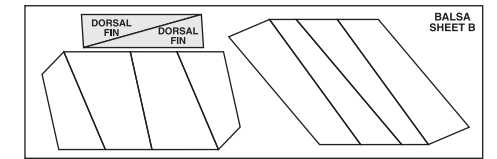
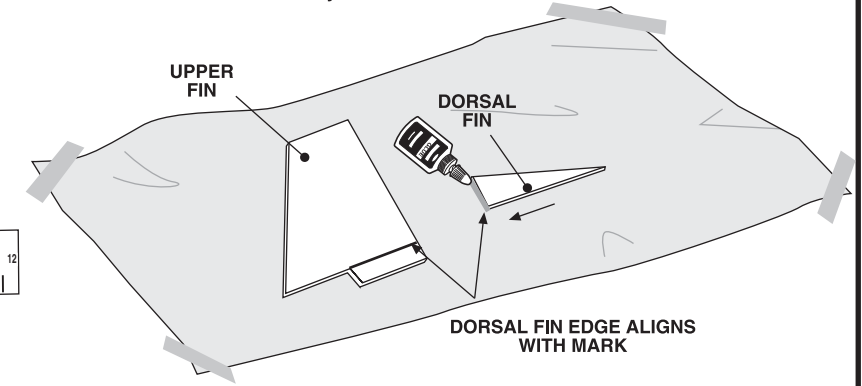

C. Using 220 sandpaper, block sand the upper fin assemblies smooth.

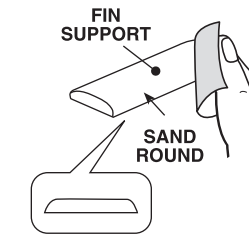
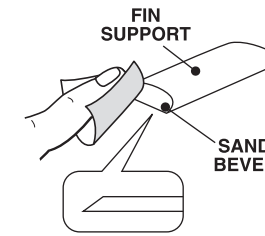
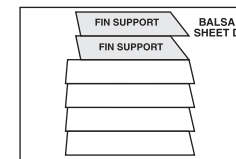
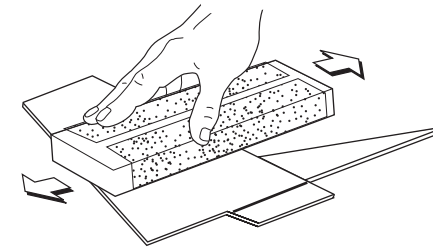

D. Using 220 sandpaper bevel each end and round off the edges of the 4 upper fin supports as shown. Apply glue to the flat side of each support and apply to each side of the upper fins where shown.

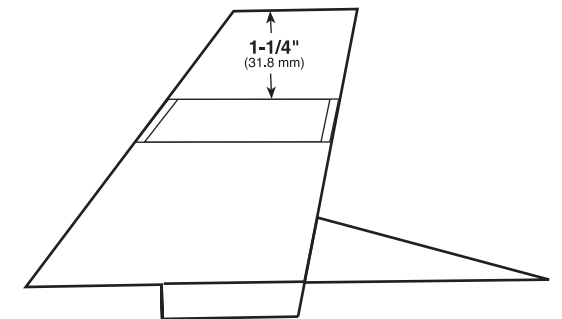

E. Sand the leading edges round and taper the trailing edges as shown.

