

# Starship NOVA

SKILL LEVEL 3 - Recommended for Craftsman Rocketeers.

RECOMMENDED ENGINES:  
B4-2 B6-2 C5-3 C6-3

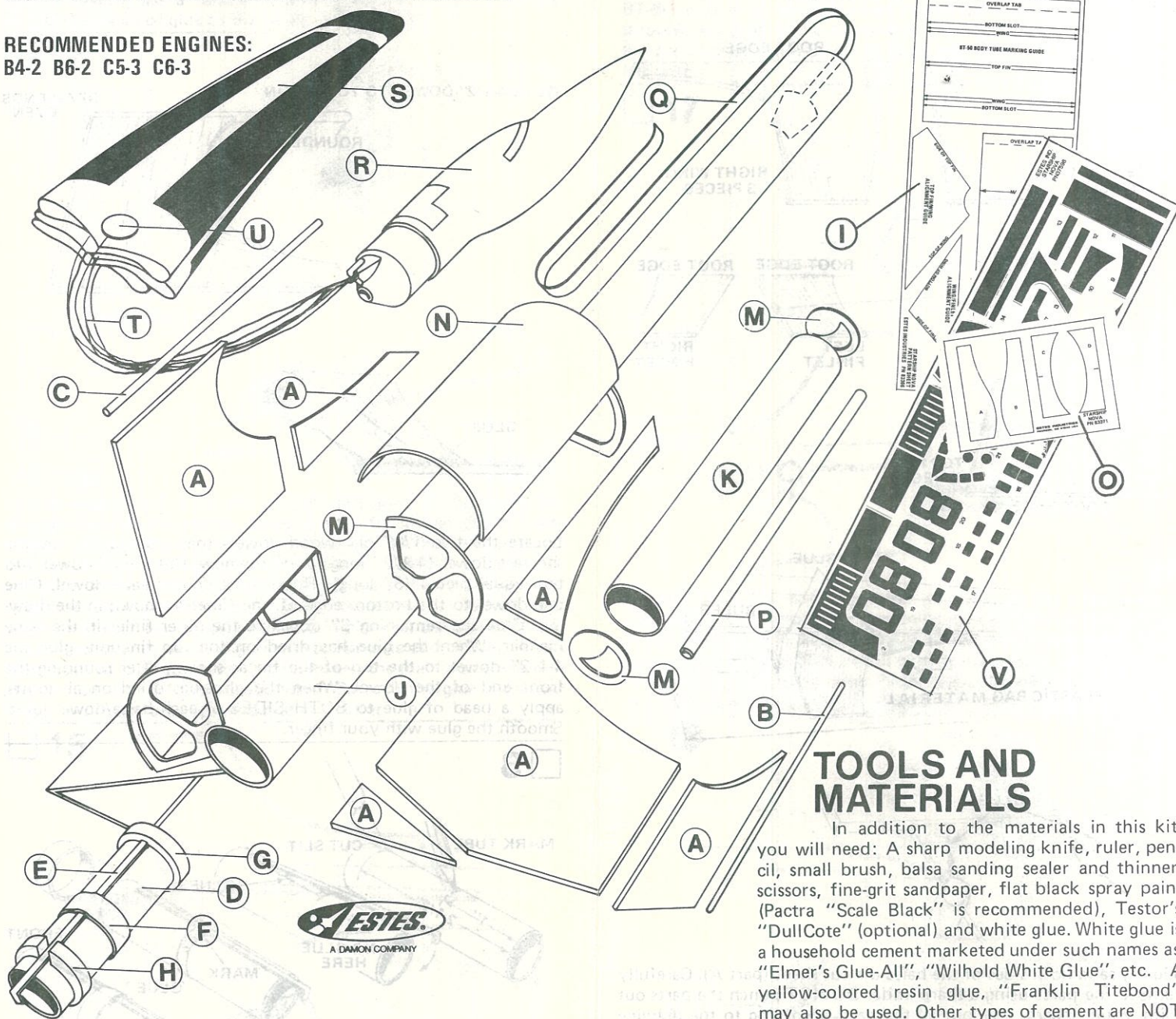

## BEFORE YOU START

Read each step and study the accompanying drawings before doing any of the work called for in that step. Always test-fit parts together before applying glue. It will sometimes be necessary to sand edges of rings, tubes, etc. to obtain a proper fit. If you are in doubt about the relative size or location of some parts, refer back to this exploded view drawing for clarification. Adequate glue joints are very important for a flying model rocket. Follow the instructions carefully in this regard.

## TOOLS AND MATERIALS

In addition to the materials in this kit, you will need: A sharp modeling knife, ruler, pencil, small brush, balsa sanding sealer and thinner, scissors, fine-grit sandpaper, flat black spray paint (Pactra "Scale Black" is recommended), Testor's "DullCote" (optional) and white glue. White glue is a household cement marketed under such names as "Elmer's Glue-All", "Wilhold White Glue", etc. A yellow-colored resin glue, "Franklin Titebond" may also be used. Other types of cement are NOT recommended.

## KIT NO. 1371

## PARTS LIST

A	1	Balsa Die-Cut Sheet (type BF-1371)	32377
B	1	1/8" Dia. Dowel - 6" long	85906
C	1	1/8" Dia. Dowel - 4-1/2" long	85903
D	1	Engine Mount Tube (type BT-20J) 2-3/4" long	30326
E	1	Engine Hook (type EH-2)	35025
F	1	Retaining Ring (type HR-20)	30168
G	1	Centering Ring (type AR-2050)	30164
H	1	Split Centering Ring (type AR-2050S)	80425
I	1	Pattern Sheet (type SP-1371A)	83366
J	1	Main Body Tube (type BT-50KE) 15" long	30364
K	1	Short Body Tube (type BT-50F) 5" long	30377

L	1	"D" Engine Casing (type EC-6) (NOT SHOWN)	35012
M	1	Die-Cut Card (type RA-1371)	32464
N	1	Body Tube (type BT-60J) 2-3/4" long	30412
O	1	Printed Card (type SP-1371B)	83371
P	1	Launch Lug (type LL-2C)	38180
Q	1	Shock Cord (type SC-1)	85730
R	1	Nose Cone (type PNC-50F)	71030
S	1	Parachute (type PK-18A)	85566
T	1	Shroud Line (type SLT-108)	38239
U	1	Tape Disc Set (type TD-3F)	38406
V	1	Decal Sheet (type KD-1371)	37598



# ASSEMBLY INSTRUCTIONS

**NOTE:** The following assembly steps have been intermixed to speed up construction of the rocket. For example, while glue is drying from one step, the instructions will alternate to another set of parts. The instructions will come back to the initial step after the glue has had time to dry. There will, however, be some waiting time. Do not proceed with an assembly step until the glue applied to that part in a previous step has **THOROUGHLY** dried.

## 1 Balsa Parts Layout

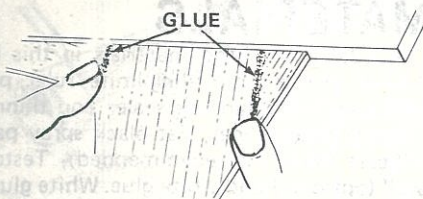
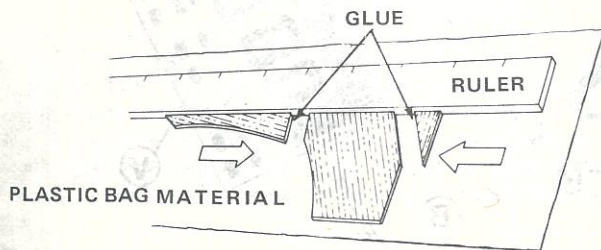
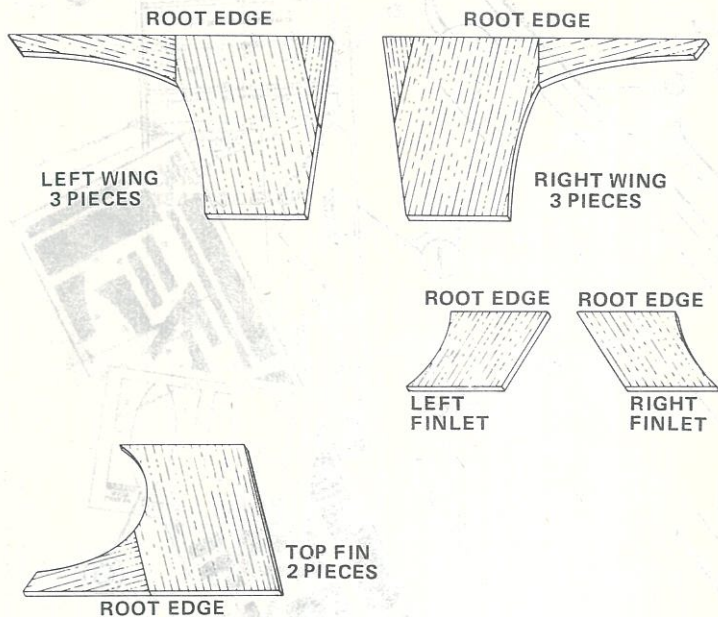

Lightly sand both sides of the balsa die-cut sheet (part A). Carefully remove the parts using a sharp knife. **DO NOT** punch the parts out with your fingers. Lay out all the parts according to the drawing above. Cut a large section from the plastic bag to use as a gluing surface. Place the plastic on a flat surface and lay the parts for the left wing on the plastic. Using a ruler for a straightedge, butt the root edges of the parts against it. Smear a thin film of glue into the edges of the parts where they are to be glued together. **DO NOT** join the parts, but allow the glue to dry for a few minutes. Smear a second film of glue on the mating edges and press the parts together. Make sure the root edges of the parts are against the ruler. Smear a thin film of glue over the surface of the joints and allow assembly to dry. After the glue has dried, turn the wing over and smear a film of glue over the joints of the opposite side. Glue the right wing and the top fin together in the same manner. The top fin consists of just two pieces.

## 2

GLUE 3" DOWEL TO FINLET

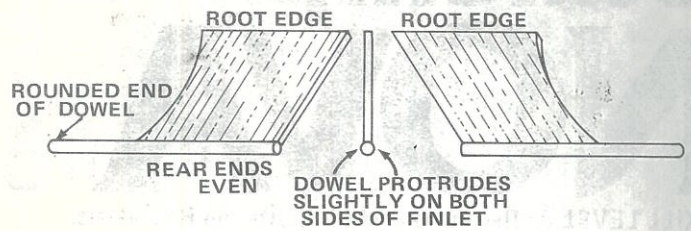

GLUE 4-1/2" DOWEL TO TOP OF FIN

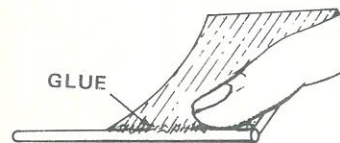
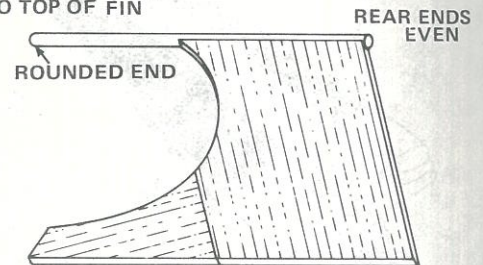

Locate the two 1/8" dia. wood dowels (parts B and C). Lay the shortest dowel (4-1/2" long) aside for now. Cut the 6" dowel into two equal pieces (3" long). Round one end of each dowel. Glue one dowel to the bottom edge of one finlet as shown in the drawing. Glue the remaining 3" dowel to the other finlet in the same manner. When the glue has dried on the top fin unit, glue the 4-1/2" dowel to the top of the fin as shown, after rounding the front end of the dowel. When the glue has dried on all joints, apply a bead of glue to **BOTH SIDES** of each balsa/dowel joint. Smooth the glue with your finger.

## 3

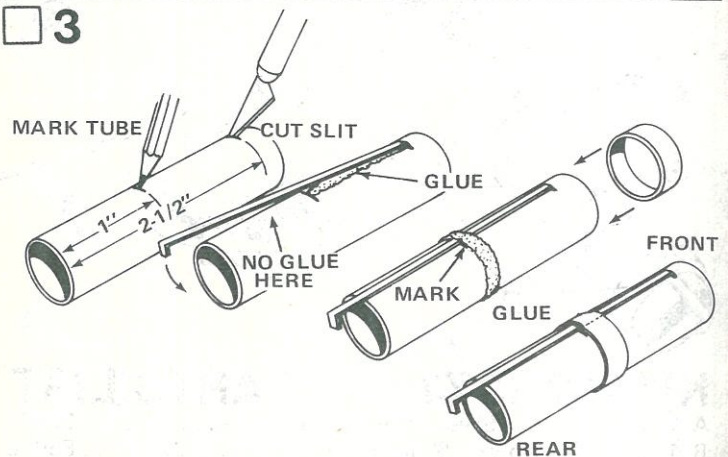

Mark the engine mount tube (part D) at 1" and 2-1/2" from one end. Cut a 1/8" long slit at the 2-1/2" mark. Apply a bead of glue between the slit and the 1" mark. Insert one end of the engine hook (part E) into the slit and press the hook into the glue. Align hook so it runs straight along tube. Apply a bead of glue around the tube just forward of the 1" mark. Slip the retaining ring (part F) onto the front of the tube and slide rearward until it reaches the 1" mark. Wipe away excess glue. Check the hook to make sure it runs straight along the tube.



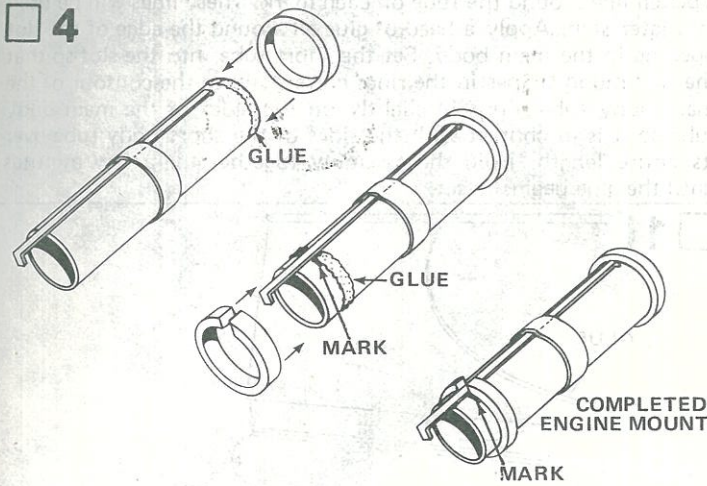

Apply a bead of glue around the front of the tube and slide the centering ring (part G) onto the front of the tube. Place a mark on the tube 1/4" from the rear. Apply a bead of glue around the tube just forward of this mark. Do not get glue on the engine hook. Slide the split centering ring (part H) over the rear of the tube and push forward until the rear of the ring is even with the mark. Make sure the engine hook is centered in the split portion of the ring. Hold the ring in place until the glue partially dries.

**5** When the glue on the balsa parts has dried, they are ready to be sealed. Lightly sand both sides and all edges of the top fin, wings and finlets. Be careful not to round any edges; they should remain square. Apply a coat of balsa sanding sealer to all edges EXCEPT ROOT EDGES. Try not to get any sealer on the root edges (see drawing in Step 1). Lay the parts down and coat one side with sealer. When the sealer is dry, turn the parts over and coat the other side. Allow the sealer to dry, then sand all surfaces. This operation should be repeated at least one or possibly two more times in order to obtain a very smooth, grain-free surface. While waiting for sealer to dry, you may skip ahead through the next four steps.

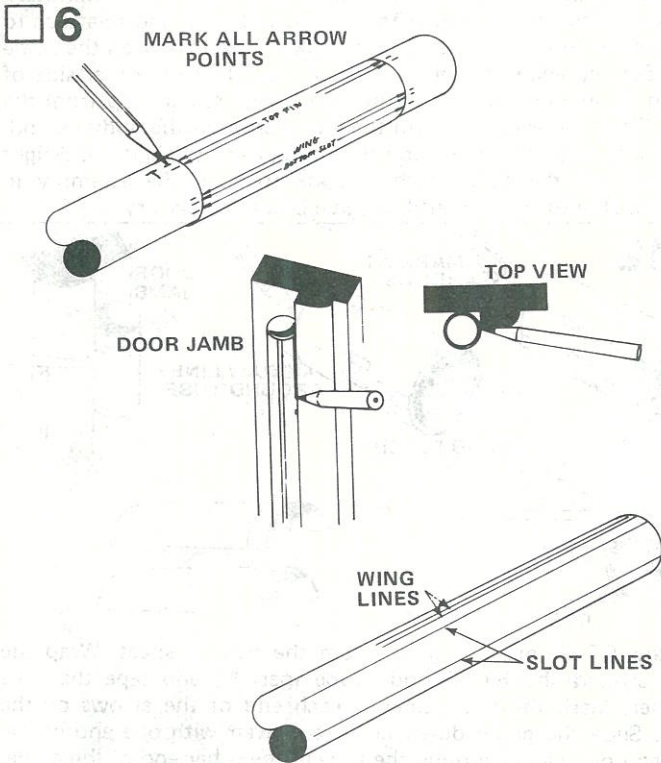

Cut the BT-50 body tube marking guide from the pattern sheet (part I). Wrap the guide around the main body tube (part J) about

1" from one end of the tube and tape the ends of the guide together. Accurately mark the tube at each end of the arrows on the guide. Print the letter "T" next to the top fin marks for later identification. Place the body tube against a door jamb and, using that as a guide, draw lines connecting the marks. The lines for the fins and wings should be extended along the tube for a distance of about 6". The two lines for the bottom slot (opposite top fin) should extend along the tube for 9".

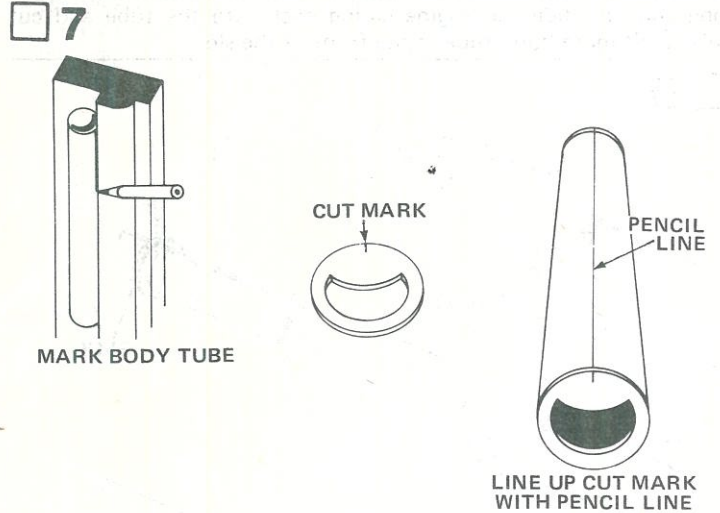

Place the 5" long body tube (part K) against a door jamb and draw a line along the length of the tube. Remove the two small rings from the die-cut card (part M). There is a small cut mark at the top of each ring. Glue the rings to the ends of the tube with the cut marks lined up with the pencil line.

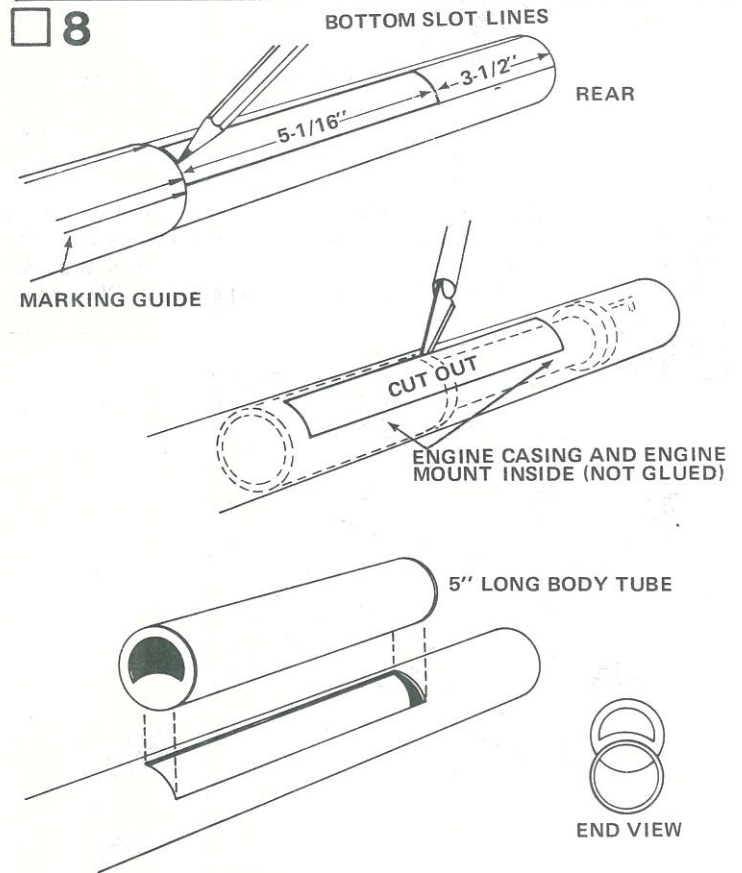

The object of this step is to cut a slot in the main body tube so that the 5" long body tube will nest partially into the main tube. Study the drawings before beginning.

Rotate the main body tube so that the two slot lines are facing up. Mark the tube 3-1/2" from the end. Mark the tube again, 5-1/16" forward of the first mark. Draw lines across the tube on these



marks to connect the bottom slot lines. Wrap the marking guide around the tube and use one end of it as a guide for drawing these lines. Slip the "D" engine casing (part L) and the engine mount into the tube and slide them forward until they are beneath the area of the slot. These will reinforce the tube during the cutting operation. Carefully cut out the slot. **CUT SLOWLY AND LIGHTLY.** Use several light cuts to cut through the tube. Once the slot is cut out, remove the engine mount and casing. Test-fit the 5" body tube into the slot. It should fit as shown. If the slot is not long enough, slide the engine casing back into the tube and cut away a bit more body tube at the front of the slot.

9

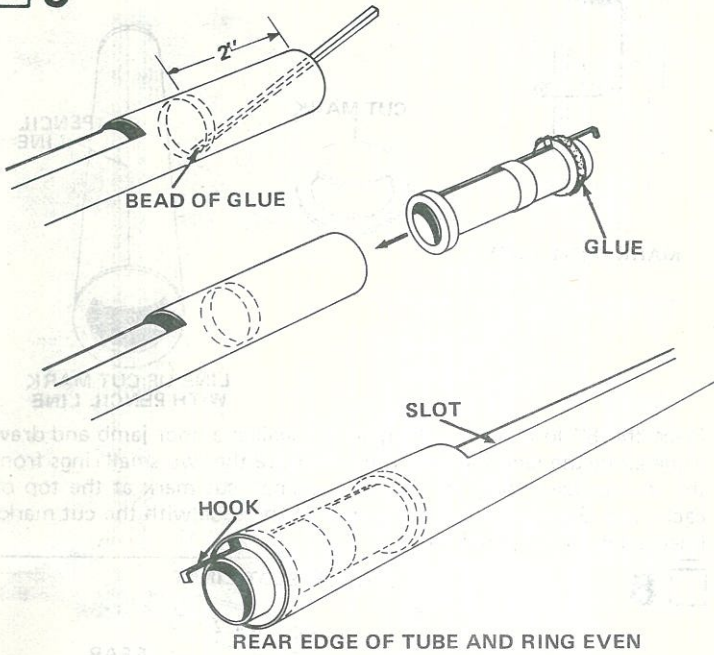

Use the stick to apply a generous bead of glue 2" inside the rear of the main body tube (this is the end with slot and pencil marks). **DO NOT GLUE THE MOUNT INTO THE WRONG END OF THE BODY TUBE.** Apply a light bead of glue to the rear (split) centering ring of the engine mount. Slide the mount into the tube with the engine hook and slot aligned. Push the mount in until the rear edges of the body tube and split centering ring are even. Wipe away excess glue.

10

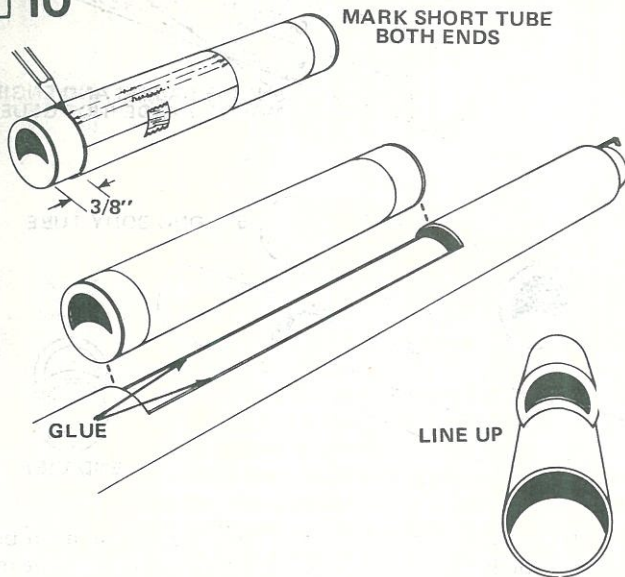

Mark the 5" body tube at a point 3/8" from EACH END. Wrap the marking guide around the tube and use one end as a guide to draw

a pencil line around the tube on each mark. These lines will be used in a later step. Apply a bead of glue all around the edge of the slot opening in the main body. Set the short tube into the slot so that the half-moon shapes in the rings correspond to the contour of the main body tube. Press in slightly on the sides of the main body tube so it is in contact with the sides of the short body tube over its entire length. Hold the assembly together for a few minutes until the glue begins to set.

11

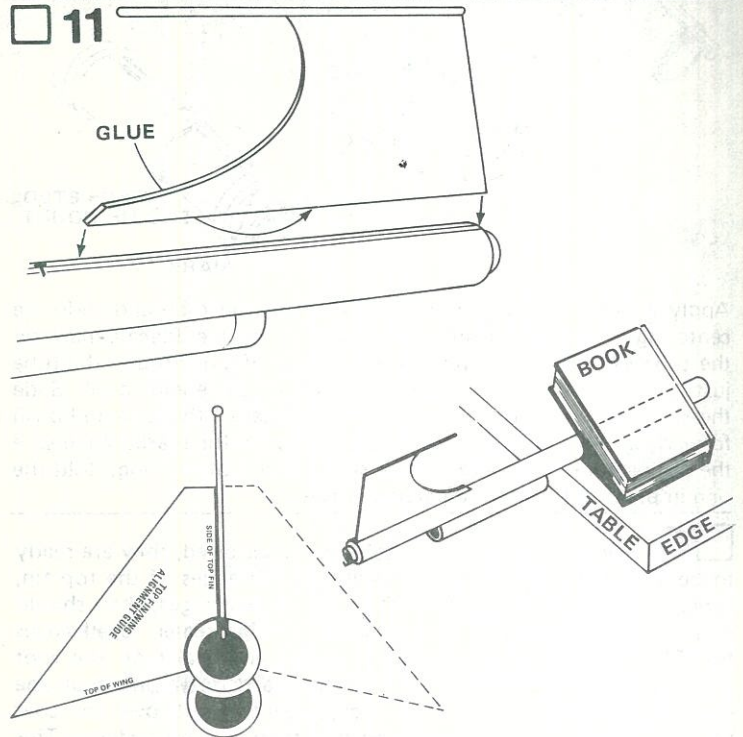

Cut the top fin/wing alignment guide from the pattern sheet. Apply a light bead of glue to the root edge of the top fin. Attach the fin to the body with the rear edge of fin and body tube even and the fin exactly between the top fin guide lines. Remove fin immediately and allow glue to partially dry on both surfaces (2 - 3 minutes). Apply a second bead of glue to the fin root edge and re-attach to body. Make sure the fin is accurately positioned between the guide lines. Set the alignment guide on first one, then the other side of the fin as shown. Adjust the fin so it points straight up from the body. Place the assembly with the rear section of the body extending off the edge of a table and the fin pointing straight up. Weight the front of the body with a book to keep the assembly in position. Do not disturb until the glue is completely dry.

12

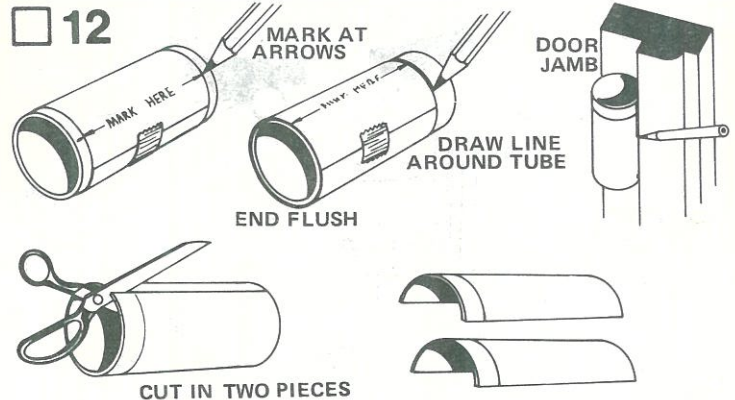

Cut the BT-60 marking guide from the pattern sheet. Wrap the guide around the BT-60 body tube (part N) and tape the ends together. Mark the body tube at each end of the arrows on the guide. Slide the guide down until it is even with one end of the tube and draw a line around the tube at the other end of the guide. Remove the guide, place the body tube against a door jamb and draw lines along the tube on the pencil marks. Cut along the lines with a pair of scissors so that you end up with two half-body tubes as shown.



□ 13

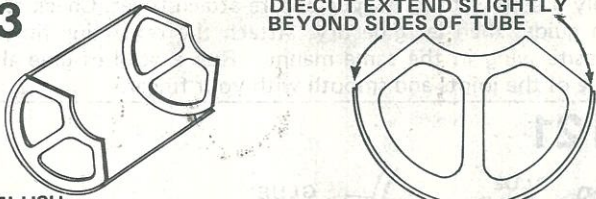

DIE-CUT EXTEND SLIGHTLY BEYOND SIDES OF TUBE

TUBE ENDS FLUSH

Remove the 4 large shapes from the die-cut card (part M). These are glued into the half-body tubes as shown. Once the die-cuts are glued in place, use a balsa stick (from fin scrap) to apply a small reinforcing bead of glue to the inside of each joint.

□ 14

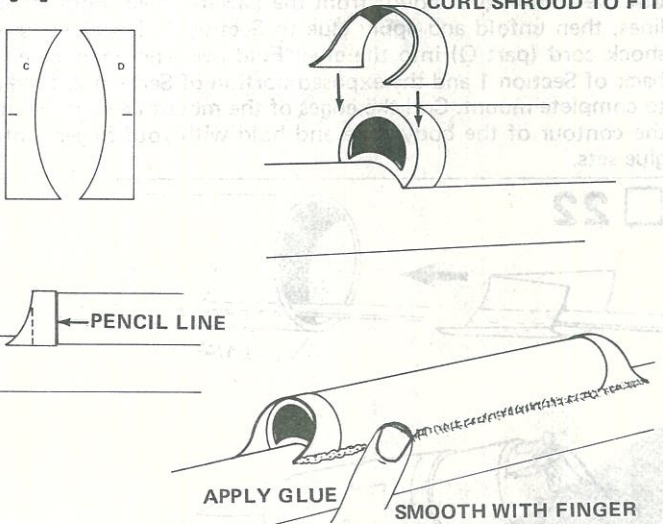

CURL SHROUD TO FIT

PENCIL LINE

APPLY GLUE

SMOOTH WITH FINGER

Cut shrouds C & D from the printed card (part O). Pre-curl these shrouds around the engine casing so they fit around the 5" body tube as shown. The shrouds are positioned with their rear edges on the pencil lines that were drawn in Step 10. Test-fit a shroud onto the tube. If the ends of the shroud don't quite meet the main body tube, the gap can be filled with glue. If the shroud is too long, trim a bit off of each end. Glue the shroud in place on one end of the 5" tube. Repeat with remaining shroud at opposite end of tube. Run a light bead of glue along the joint between the main body tube and the shrouds and 5" tube (both sides). Smooth the glue with your finger to provide a smooth seam at each joint.

□ 15

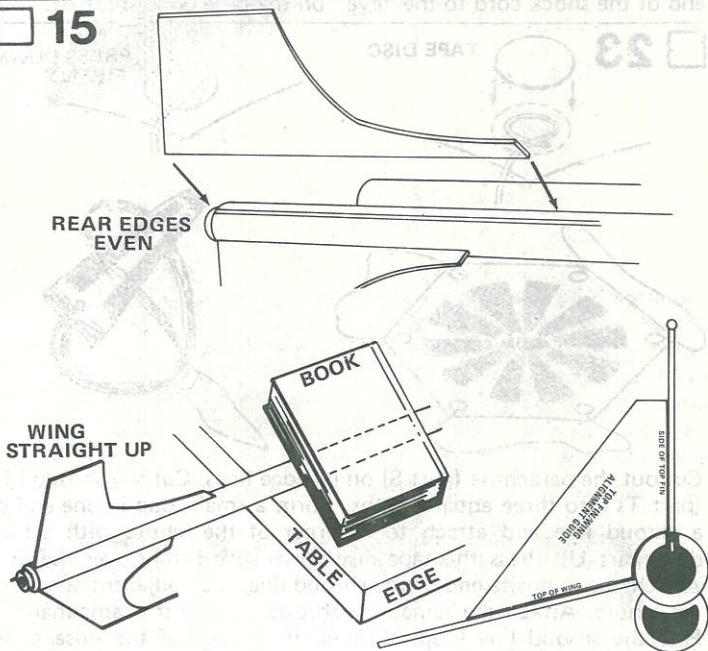

REAR EDGES EVEN

WING STRAIGHT UP

BOOK

TABLE EDGE

TOP FINISHING BRUSH

TOP OF WING

Proceed ONLY if the glue on the top fin is completely dry. Attach the left wing to the body using the same procedure as in Step 11.

□ 16

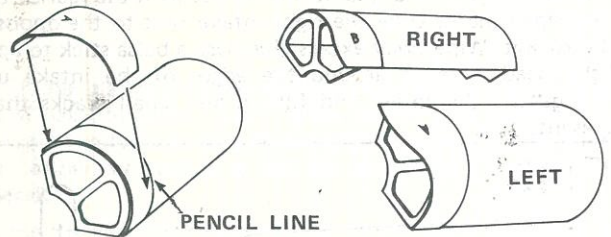

RIGHT

LEFT

PENCIL LINE

Cut shrouds A and B from the printed sheet and attach to the BT-60 units in a similar manner as you did in Step 14. Pre-curl the shrouds and glue to the tubes with the rear edge of the shrouds on the pencil lines (from Step 12). Note that there is a right unit and a left unit.

□ 17

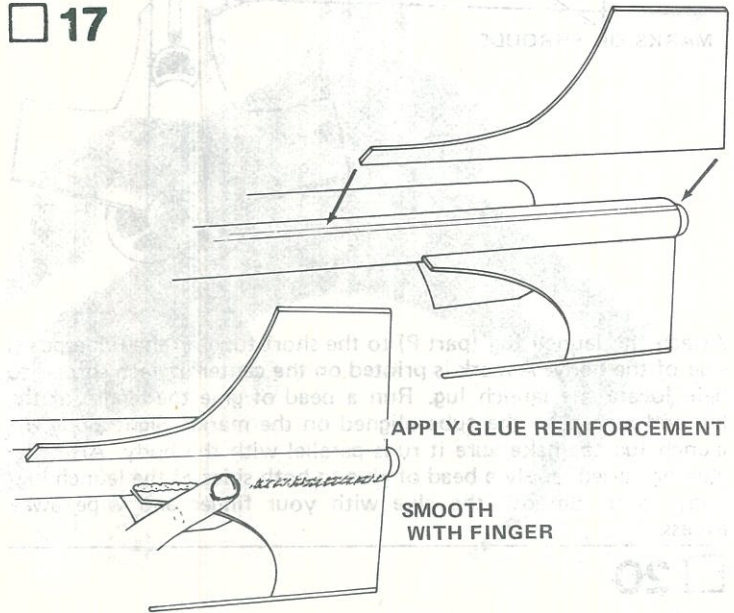

APPLY GLUE REINFORCEMENT

SMOOTH WITH FINGER

Proceed with this step only after the glue on the other wing is completely dry. Attach the remaining wing in the manner outlined in Steps 11 and 15. Allow the glue to dry completely, then apply glue reinforcements. Run a bead of glue along both sides of the top fin/body tube joint. Pull your finger along the joint, smoothing the glue. Remove any excess glue. Repeat with both wings.

□ 18

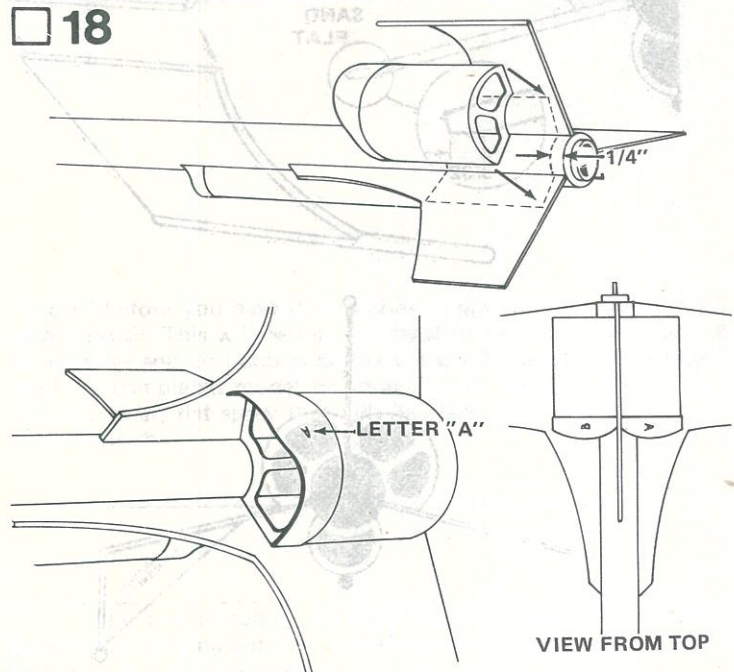

1/4"

LETTER "A"

VIEW FROM TOP

Mark the body 1/4" from the rear edge on both sides of the top fin. Run a bead of glue around the edges of left intake unit (letter



"A" on shroud) and glue to the rocket with the rear of the unit on the pencil mark. Glue the right intake unit to the opposite side of the rocket. Wipe away excess glue. Use a balsa stick to apply a very light bead of glue around the edges of the intake units. This strengthens the joints and fills in any small cracks that may be present.

19

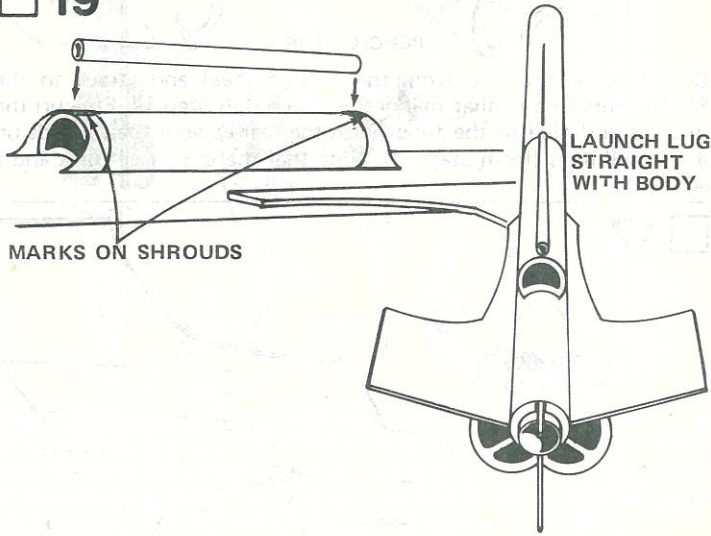

Attach the launch lug (part P) to the short tube on the underneath side of the body. A mark is printed on the center of each shroud to help locate the launch lug. Run a bead of glue the length of the lug and attach to the tube aligned on the marks. Sight along the launch lug to make sure it runs parallel with the body. After the glue has dried, apply a bead of glue to both sides of the launch lug/body joint. Smooth the glue with your finger and wipe away excess.

20

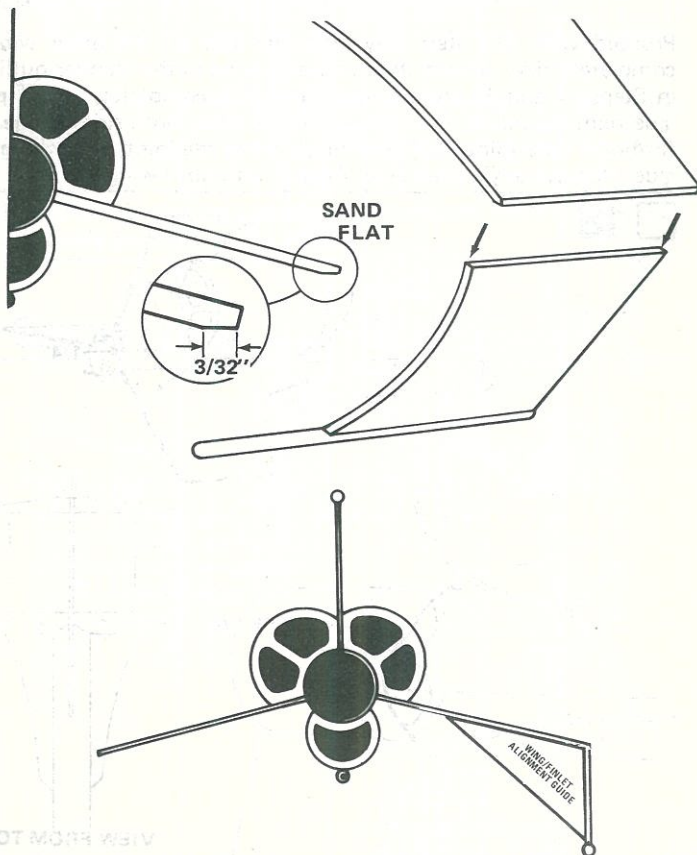

Sand a flat on the bottom side of each wing as shown. Cut the wing/finlet alignment guide from the pattern sheet. Apply a bead of glue to the root edge of one finlet, attach to wing, then remove.

Apply a second bead of glue and re-attach finlet. Check alignment with guide, then let glue dry. Attach the remaining finlet to the opposite wing in the same manner. Run a bead of glue along the inside of the joints and smooth with your finger.

21

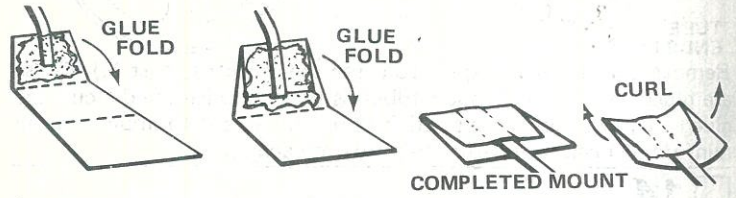

Cut the shock cord mount from the pattern sheet. Fold on dotted lines, then unfold and apply glue to Section 1. Lay the end of the shock cord (part Q) into the glue. Fold over and apply glue to the back of Section 1 and the exposed portion of Section 2. Fold again to complete mount. Curl the edges of the mount up so it will match the contour of the body tube and hold with your fingers until the glue sets.

22

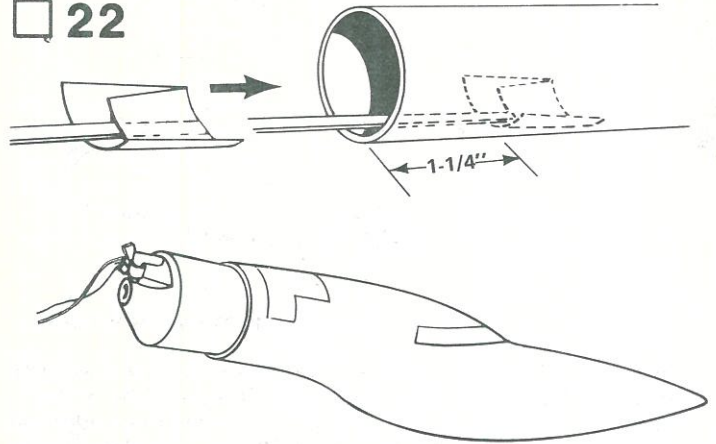

The shock cord is glued into the front of the body tube 1-1/4" from the end. This allows clearance at the front of the tube for the nose cone to socket into place. Use a stick to deposit a generous dab of glue inside the body tube, 1-1/4" from the end. Slide the shock cord mount into the tube and press into the glue. To ensure a good bond, use the stick or your finger to smear a film of glue over the mount and the surrounding area in the body tube. Tie the free end of the shock cord to the "eye" on the nose cone (part R).

23

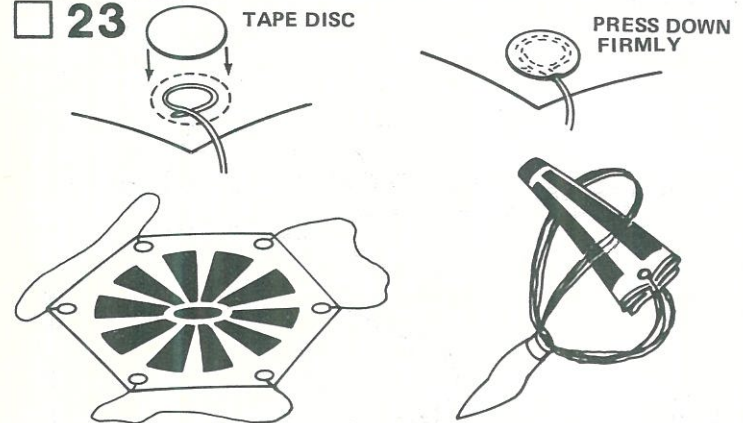

Cut out the parachute (part S) on its edge lines. Cut the shroud line (part T) into three equal lengths. Form a small loop in one end of a shroud line and attach to a corner of the 'chute with a tape disc (part U). Press the tape disc down very firmly over the line. Attach the opposite end of the shroud line to an adjacent corner of the 'chute. Attach the remaining shroud lines in the same manner. Pass the shroud line loops through the "eye" of the nose cone. Pass the 'chute through the loops and draw the lines tight. Fold the 'chute, pack 'chute and shock cord into body and socket nose cone into place.



## PAINTING AND DETAILING

Before painting, clean the rocket with a slightly damp cloth to remove oily fingerprints. The entire rocket is painted flat black. We recommend Pactra Military Flat Scale Black (spray enamel). This is a gray-black color that shows the detail well. DO NOT paint the model with lacquer paint. Lacquer paint will mar

the finish of the plastic nose cone. Spray the model with several light coats of paint to avoid "runs". Spray into the openings of the two large intake units from several directions to cover the interior with paint. Allow the rocket to dry for at least 2 hours before applying decals.

## DECAL PLACEMENT

NUMBERS IN ○ INDICATE  
OPPOSITE SIDE OF ROCKET

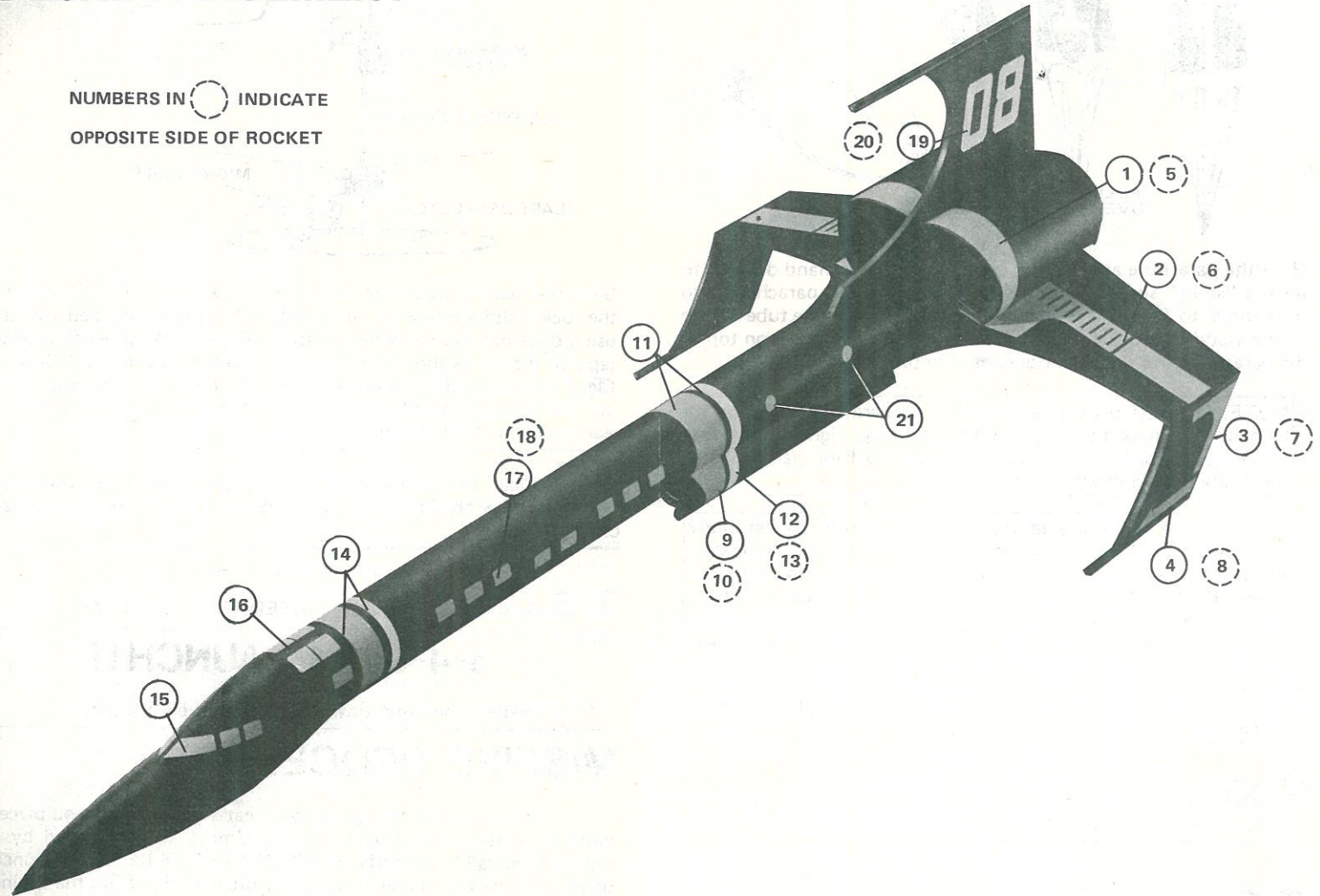

The decal sheet (part V) has numbers printed next to each decal. The decals should be applied in numerical order. Refer to the photograph for location of the decals. To apply decal, cut one decal at a time from the sheet. Submerge decal in water for 15 to 30 seconds (until decal slides on backing paper). Gently slide decal from backing paper onto model. Move decal into exact position and carefully blot away excess water with a soft cloth. If the decal

"sticks" before you have it in position, apply water over the decal with a brush. This will permit the decal to be moved. Smooth out all wrinkles and air bubbles before the decal dries. We recommend that the completed model be sprayed with Testor's "DullCote". This is a clear, flat spray that kills the decal shine and protects the model's finish.

## LAUNCHING COMPONENTS

To launch your rocket you will need the following items:  
An Estes model rocket launch system  
Parachute recovery wadding (Estes Cat. No. 2274)  
Recommended Engines: B4-2, B6-2, C5-3, or C6-3.  
Use a B4-2 engine for your first flight.

Be sure to follow the HIAA-NAR\* Model Rocket Safety Code when carrying out your model rocket activities.

\*HIAA -- Hobby Industry Association of America  
NAR -- National Association of Rocketry



# COUNTDOWN CHECKLIST

## T-13

Pack 4 squares of loosely crumpled recovery wadding into the rocket body.

## T-12

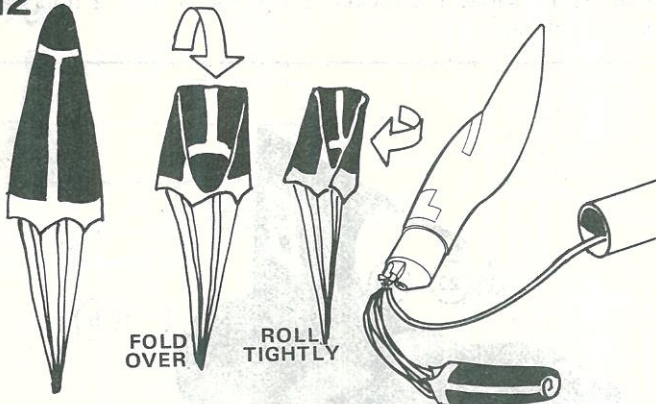

Hold the parachute at its center and pass the other hand down it to form a "spike" shape. Fold this spike in half. Roll parachute into tube shape to fit easily into body. Pack 'chute into the tube on top of the wadding. Pack the shroud lines and shock cord in on top of the parachute and slip the nose cone into place.

**NOTE:** DO NOT pack parachute until you are actually ready to launch. For maximum parachute reliability, lightly dust the 'chute with ordinary talcum powder before each flight, especially in cold weather.

**NOTE:** Nose cone should separate easily from rocket body tube, but should not be extremely loose. If fit is too tight, sand inside of body tube and shoulder of nose cone with fine sandpaper. If fit is too loose, add a wrapping of transparent tape or masking tape to the shoulder of the nose cone.

**T-11** Install an igniter in the engine as directed in the engine instructions.

**T-10** Insert engine into rocket engine mount. Engine hook must latch securely over end of the engine.

**T-9** Disarm the launch panel -- REMOVE SAFETY KEY!

## T-8

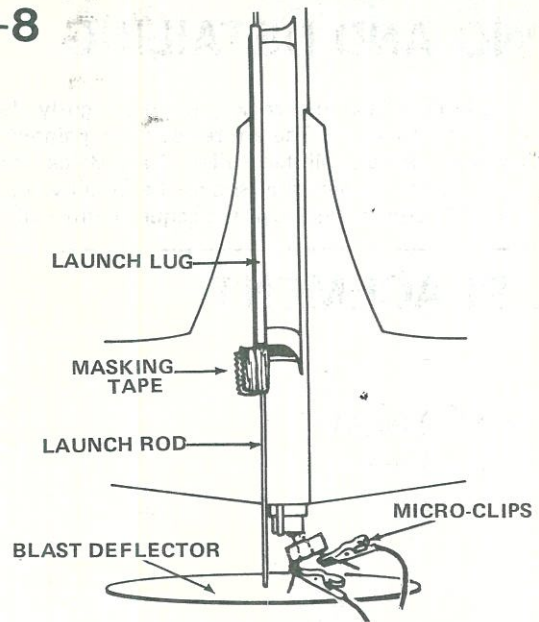

Slide the launch lug of the rocket onto the launch rod. Make sure the rocket slides freely on the launch rod. If the launch pad you are using does not have a deflector stand-off, place a piece of masking tape on the rod as shown to keep the rocket 2" above the deflector. Clean the micro-clips and attach them to the igniter wires as close to the tape as possible. Arrange the clips so they do not touch each other or the metal blast deflector.

**T-7** Clear the launch area, alert recovery crew and trackers. Check for low flying aircraft and unauthorized persons in the recovery area.

**T-6** Arm the launch panel -- INSERT SAFETY KEY!

# -5-4-3-2-1-LAUNCH!!

Repeat the Countdown Checklist for each flight.

## MISFIRE PROCEDURE

Occasionally the igniter will heat and burn into two pieces without igniting the engine. This is almost always caused by a failure to install it correctly. REMOVE SAFETY KEY from launch panel, remove the model, clean the igniter residue from the engine nozzle, and install a new igniter. Repeat the Countdown Checklist.