

INCHES  
1  
2  
3  
4  
5  
6  
7  
8  
9  
10

# ESTES MINI SHUTTLE

SKILL LEVEL 2 -  
RECOMMENDED FOR THE INTERMEDIATE ROCKETEER

RECOMMENDED ENGINES:  
A8-3, B4-4, B4-6, B6-4, B6-6, B8-5,  
C6-5, C6-7, First Flight A8-3

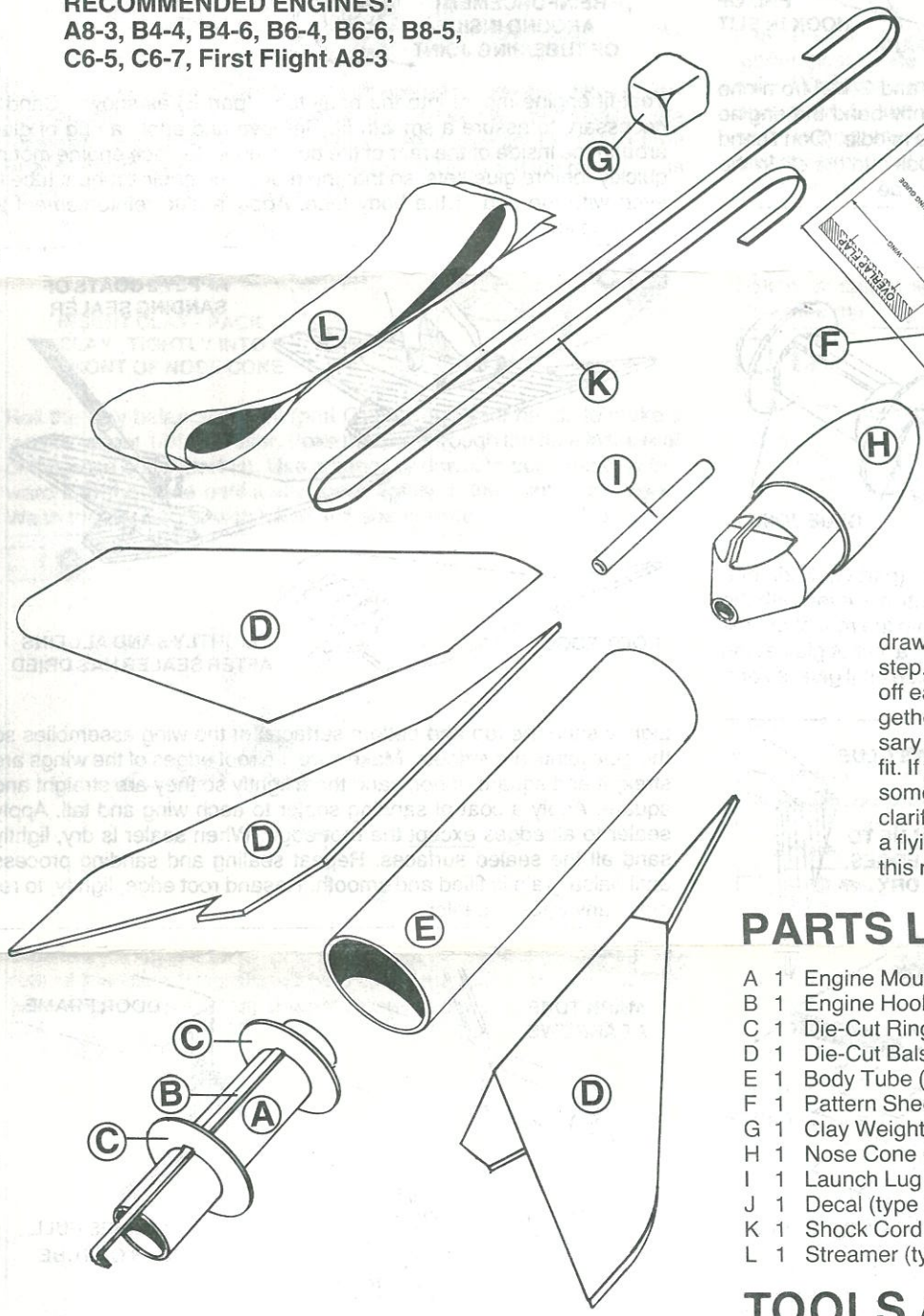
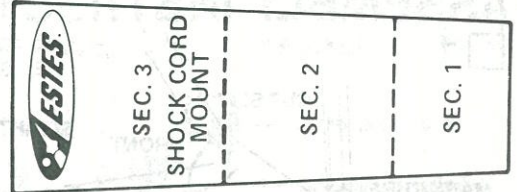

## BEFORE YOU START

Read each step and study the accompanying drawings before doing any of the work called for in that step. Make sure you have all parts and materials. Check off each step as you complete it. Always test-fit parts together before applying glue. It will sometimes be necessary to sand edges of rings, tubes, etc. to obtain proper fit. If you are in doubt about the relative size or location of some parts, refer back to this exploded view drawing for clarification. Adequate glue joints are very important for a flying model rocket. Follow the instructions carefully in this respect.

## PARTS LIST KIT NO. 1391

A	1	Engine Mount Tube (type BT-20J)	30326
B	1	Engine Hook (type EH-2)	35025
C	1	Die-Cut Rings (type RA-2060)	30128
D	1	Die-Cut Balsa (type BF-1391)	32396
E	1	Body Tube (type BT-60R)	30418
F	1	Pattern Sheet (type SP-1391)	83447
G	1	Clay Weight (type 1/2" square)	85263
H	1	Nose Cone (type PNC 60 MS)	71020
I	1	Launch Lug (type LL-2A)	38175
J	1	Decal (type KD-1391)	37533
K	1	Shock Cord (type SC-1B)	85734
L	1	Streamer (type RS-20)	38278

## TOOLS AND MATERIALS

In addition to the parts included in this kit you will need: Scissors, pencil, ruler, masking tape, fine or extra-fine grit sandpaper, sanding sealer, a medium-size modeling paint brush, modeling knife with sharp blade, gloss white and gloss black enamel spray paint, a bottle of gloss black enamel paint, and household white glue or resin glue (Elmer's, Titebond or similar). Other types of glue are not recommended. For easy and positive alignment of the fins on your model, we recommend the use of Estes' Fin Alignment Guide, Part No. 2231.



ESTES INDUSTRIES  
PENROSE, CO 81240 USA



# ASSEMBLY INSTRUCTIONS

1

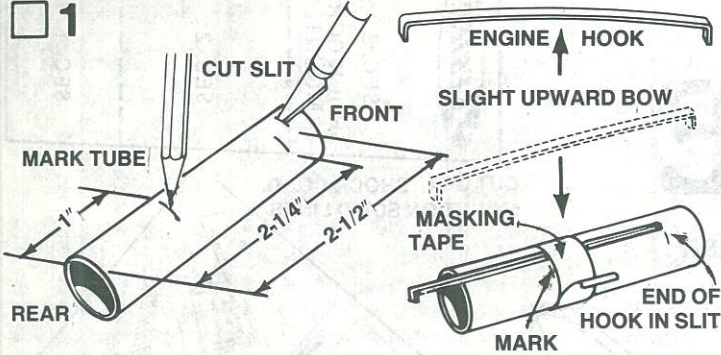

Mark the engine mount tube (part A) 1", 2-1/4", and 2-1/2" from one end. Cut a 1/8" long slit at the 2-1/2" mark. Gently bend the engine hook (part B) so it bows upward very slightly in the middle. (Don't bend the wrong way.) Insert one end of the engine hook into the slit in the tube. Hold hook in place with a wrap of masking tape.

2

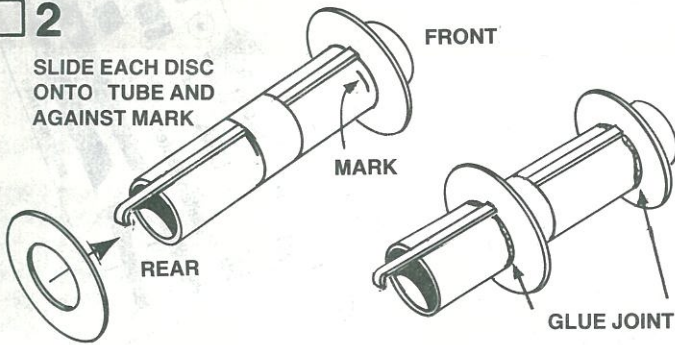

Remove the centering rings from die-cut ring set. (part C). Slide one ring onto the engine mount tube from the front until it is even with the 2-1/4" mark. Slide the remaining centering ring onto the rear of engine mount tube until it is even with the 1" mark. Apply a line of glue at the ring/tube joints on both sides of each ring. Set aside until glue is completely dry.

3

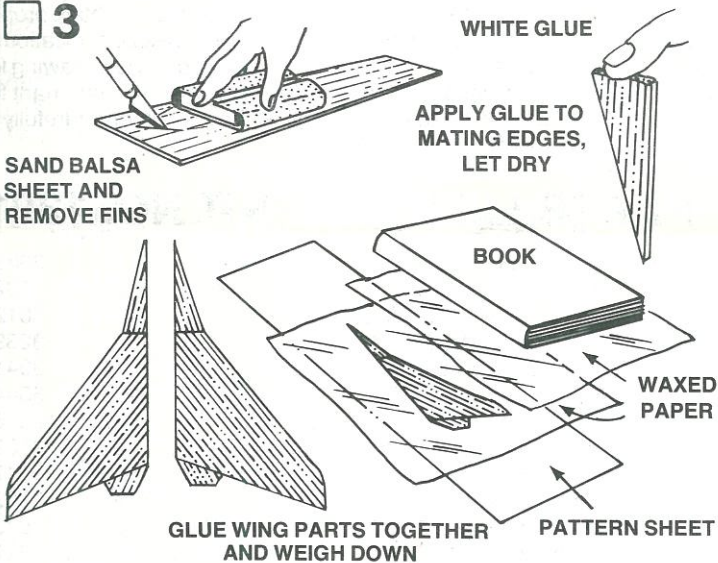

Fine-sand both sides of balsa sheet (part D), then carefully remove the tail and wing parts using a sharp knife to free the edges. Sand the edges of the parts slightly to remove any rough edges—but be careful to leave the edges square and sharp-cornered. Rub a line of glue into the mating edges of all the fin parts as shown and allow the glue to dry. Lay a piece of waxed paper on top of the pattern sheet (on back of panel) on a flat surface and apply another bead of glue to the mating parts and glue wing sections together as shown using white glue. Cover with waxed paper, weigh entire assembly down (with paint bottles or a book), and allow to dry.

4

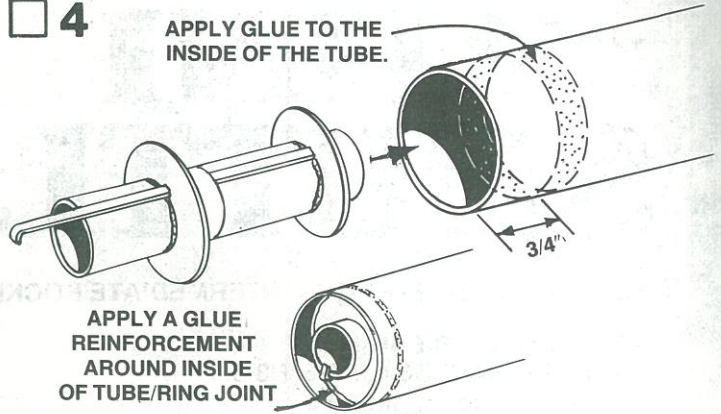

Test-fit engine mount into the body tube (part E) as shown. Sand if necessary to assure a smooth fit. Remove and apply a ring of glue around the inside of the rear of the body tube. Replace engine mount quickly, before glue sets, so that the rear of the engine mount tube is even with the end of the body tube. Apply a glue reinforcement to tube/ring joint.

5

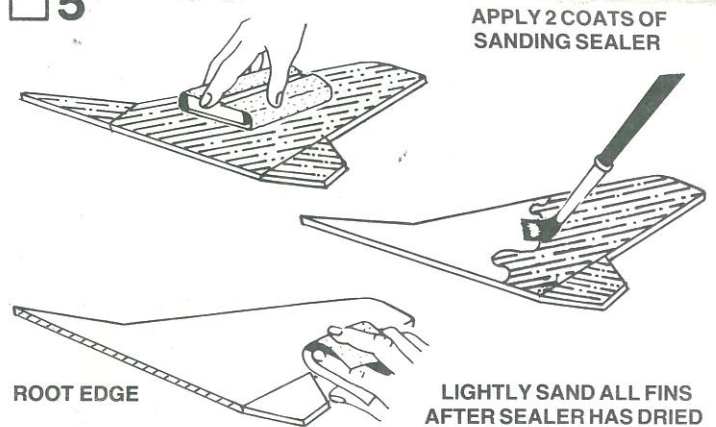

Lightly sand the top and bottom surfaces of the wing assemblies so the glue joints are smooth. Make sure the root edges of the wings are straight and square. If not, sand them lightly so they are straight and square. Apply a coat of sanding sealer to each wing and tail. Apply sealer to all edges except the root edge. When sealer is dry, lightly sand all the sealed surfaces. Repeat sealing and sanding process until balsa grain is filled and smooth. Resand root edge, lightly, to remove any trace of sealer.

6

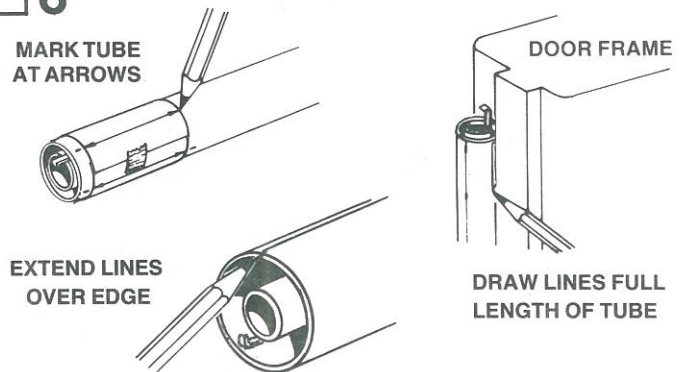

Cut out the tube marking guide from the pattern sheet (part F) and wrap it around the body tube. Line up the engine hook with the launch lug alignment line on the marking guide. Mark the body tube at each of the arrow points. Draw straight lines connecting each pair of marks. A door frame inside edge can be used as a guide as shown. Extend the lines down full length of tube. Extend the lines over the edge of the tube as shown.



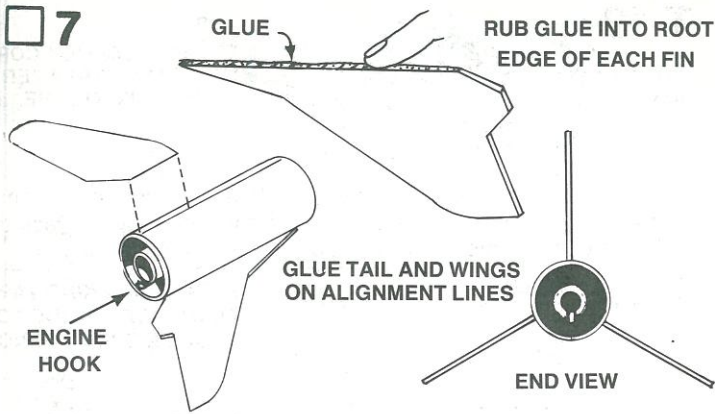

Rub glue into the root edge of each wing and the tail and allow to dry. Apply glue to the wings and tail again and position wings and tail on the alignment lines in positions shown. Adjust the wings and tail so they project straight away from the body tube. **DO NOT** set the rocket on its wings and tail while the glue is wet.

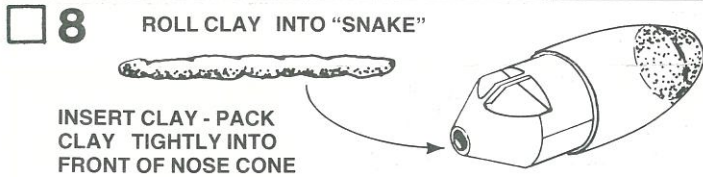

Roll the clay balance weight (part G) between your hands to make a "snake" about 1/8" diameter. Poke the clay through the hole in the rear of the nose cone (part H). Use a pencil or dowel to push the clay forward into the cone until it is packed tightly in the front of the cone. Wash the nose cone with lukewarm soapy water, rinse well, and dry.

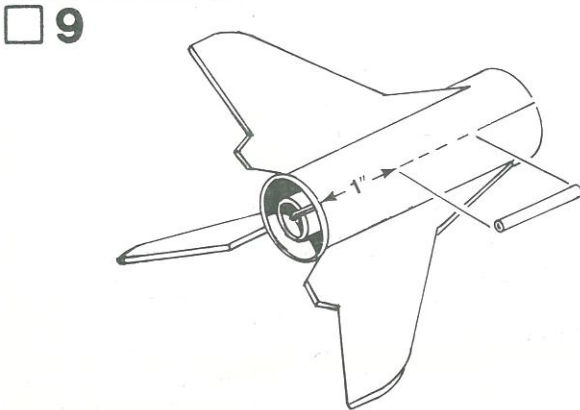

Glue launch lug (part I) to rocket body tube on the launch lug line. The rear of the launch lug should be 1" from the rear of the rocket body tube. Align the launch lug straight along the body.

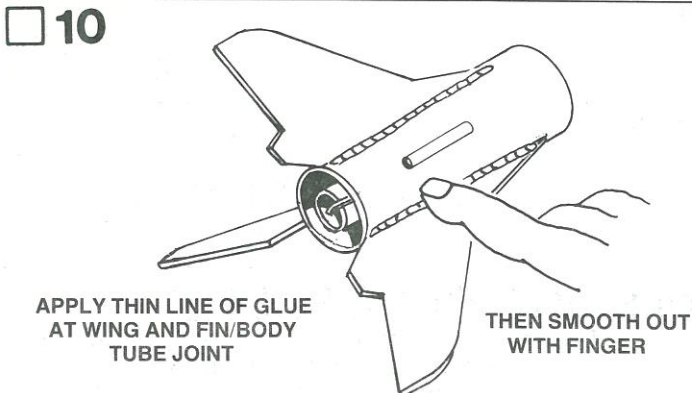

When the glue on the fin joints has dried, apply a glue reinforcement to each wing and tail body tube joint. Holding the model level, apply a line of glue to both sides of each wing and tail joint and on both sides of the launch lug. Smooth out the glue with your finger. Support rocket level (Do not stand it on the fins) until the glue dries.

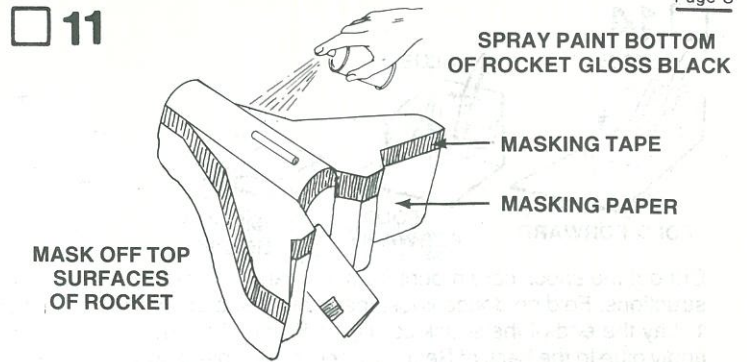

After the glue is dry, put the nose cone into place and paint the entire model gloss white. Follow instructions on the spray can for best results. We recommend spray enamel. Do not paint the model with lacquer paint. Shake can before spraying. Hold the can straight up and spray in long, smooth "strokes". Spray the model with several light, dry mist coats of paint to avoid "runs". Shake can periodically. To obtain a gloss, final coat should be applied slightly heavier. Let this coat dry overnight. Remove the nose cone and mask off the top surfaces of rocket with paper held in place with tape. Make sure there are no openings where over-spray could sift through onto the white. Paint bottom of rocket with gloss black. After the paint is dry carefully remove the masking paper and tape.

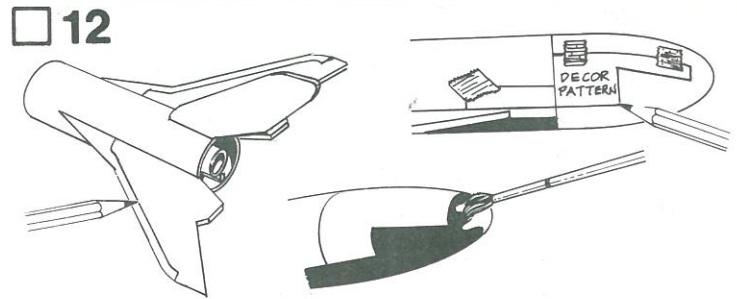

Cut out the three decor patterns from pattern sheet. Place the wing pattern on top of wing and, while holding it in place, trace around it with a pencil. Do the same with other wing. Do same procedure for both sides of tail using the tail decor pattern. Put nose cone back into place and tape the nose cone decor pattern into place and trace around side of pattern along heavy black line. Remove the patterns and paint with black bottle paint and brush along the color break lines. Paint around the tip of the nose cone connecting the front point on either side of the nose cone.

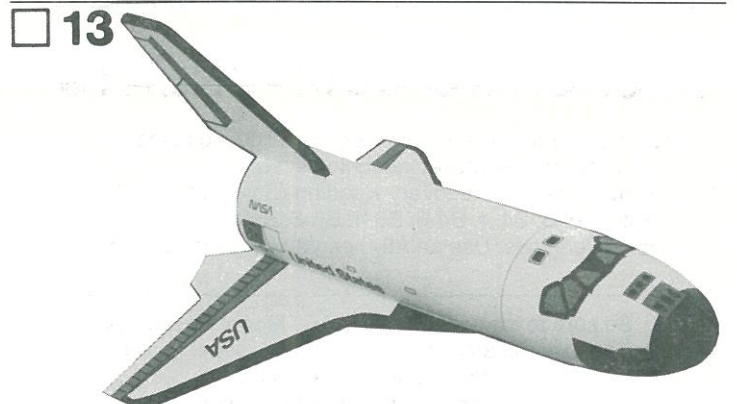

When all paint is dry, apply the decals (part J) in the positions shown. (A) Cut only one decal at a time from sheet. (B) Submerge decal in lukewarm water until decal slides on backing paper (usually 15 to 30 seconds). (C) Gently slide decal from backing paper onto model. (D) Move decal into exact position and carefully blot away excess water with a soft cloth. (E) If the decal "sticks" before you have it in position, apply water over the decal with a brush. This will permit the decal to be moved. (F) Smooth out all wrinkles and air bubbles before the decal dries. We recommend that the completed model be sprayed with Tes-tor's "Dull-Cote" or "Gloss Cote". This is a clear paint that protects the model's finish.



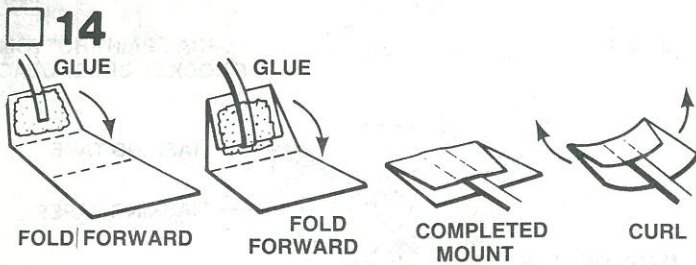

Cut out the shock cord mount from the parts illustration on front of instructions. Fold on dotted lines, then unfold and apply glue to Section 1. Lay the end of the shock cord (part K) into the glue. Fold over and apply glue to the back of Section 1 and the exposed portion of Section 2. Fold again to complete mount. Curl the edges of the mount up so it will match the contour of the body tube and hold with your fingers until the glue sets.

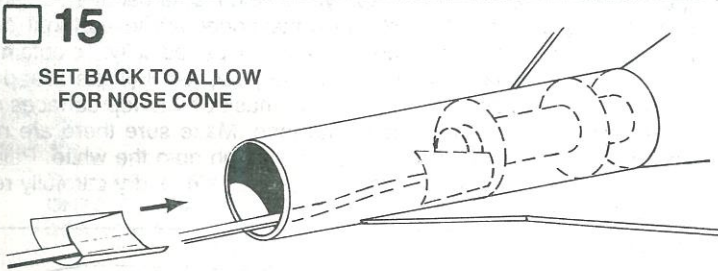

Apply glue to the side of the shock cord mount and press the mount firmly into position as far as possible down inside the body tube. This will allow clearance for the nose cone to fit into place. To insure a good bond use a stick or your finger to smear a film of glue over the shock cord mount and surrounding area in the body tube.

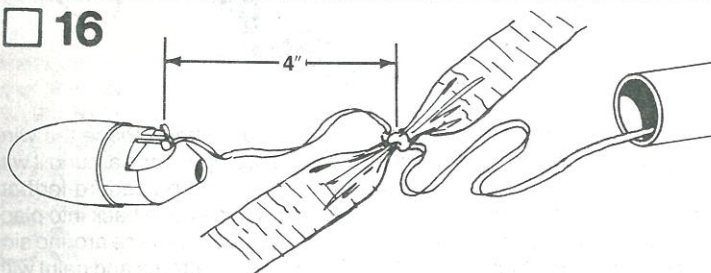

Using a double knot, tie the shock cord around the middle of the plastic streamer (part L) about 2" from the end of the shock cord. Attach the free end of the shock cord to the nose cone with a firm knot.

## LAUNCHING COMPONENTS

To launch your rocket you will need the following items:

- An Estes model rocket launching system
- Flame Resistant recovery wadding (Estes Cat. No. 2274)
- Estes A8-3, B4-4, B4-6, B6-4, B6-6, B8-5, C6-5, or C6-7 model rocket engines. Use an A8-3 engine for your first flight.

Be sure to follow the HIAA-NAR\* Model Rocket Safety Code when carrying out your model rocket activities.

- \*HIAA—Hobby Industry of America
- \*NAR—National Association of Rocketry

## COUNTDOWN CHECKLIST

### T-13

Pack 3 or 4 squares of loosely crumpled recovery wadding into the body tube. Usually this will fill the body tube for a distance equal to about 1-1/2 times its diameter.

### T-12

FOLD STREAMER IN HALF TWICE.

ROLL.



SLIDE SHOCK CORD AND STREAMER INTO TUBE.

Fold the streamer in half lengthwise. Fold again, then roll streamer lightly until the streamer fits loosely into the rocket body. Pack the shock cord neatly into the rocket body. Slide nose cone into place.

### T-11

IGNITER



INSERT IGNITER IN NOZZLE

FOLD

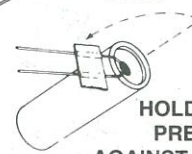

HOLD IGNITER PRESSING AGAINST NOZZLE

TAMP MASKING TAPE FIRMLY WITH FINGER OR ERASER END OF PENCIL

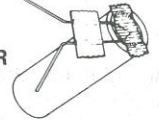

Select an engine and install an igniter as directed in the engine instructions. The first flight engine recommended for this rocket is an A8-3 made by Estes.

### T-10

ENGINE HOOK MUST LATCH SECURELY

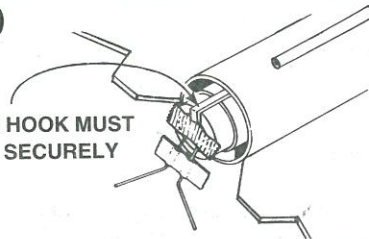

Insert engine into rocket engine mount. Engine hook must latch securely over end of the engine.

### T-9

Disarm the launch panel—REMOVE SAFETY KEY!

### T-8

LAUNCH ROD  
LAUNCH LUG  
MICRO-CLIPS  
STAND-OFF  
BLAST DEFLECTOR

Slide launch rod through rocket launch lug and place rocket on launch pad. Make sure the rocket slides freely on the launch rod. Clean the micro-clips and attach them to the igniter wires. Arrange the clips so they do not touch each other or the metal blast deflector. Attach clips as close to protective tape on igniter as possible.

### T-7

Clear the launch area. Alert recovery crew and trackers. Check for low flying aircraft and unauthorized persons in the recovery area.

### T-6

Arm the launch panel—INSERT SAFETY KEY!

## 5-4-3-2-1-LAUNCH!!

Repeat Countdown Checklist for each flight.

## MISFIRE PROCEDURE

Disarm the launch panel. Wait one minute before approaching the rocket on the launch pad. Remove the rocket, clean the igniter residue from the nozzle of the engine, and carefully install a new igniter. Repeat the Countdown Checklist.

Failure of the rocket engine to function properly is nearly always caused by a failure to install the igniter correctly. This failure permits the igniter to heat and burn into two pieces without igniting the engine.