

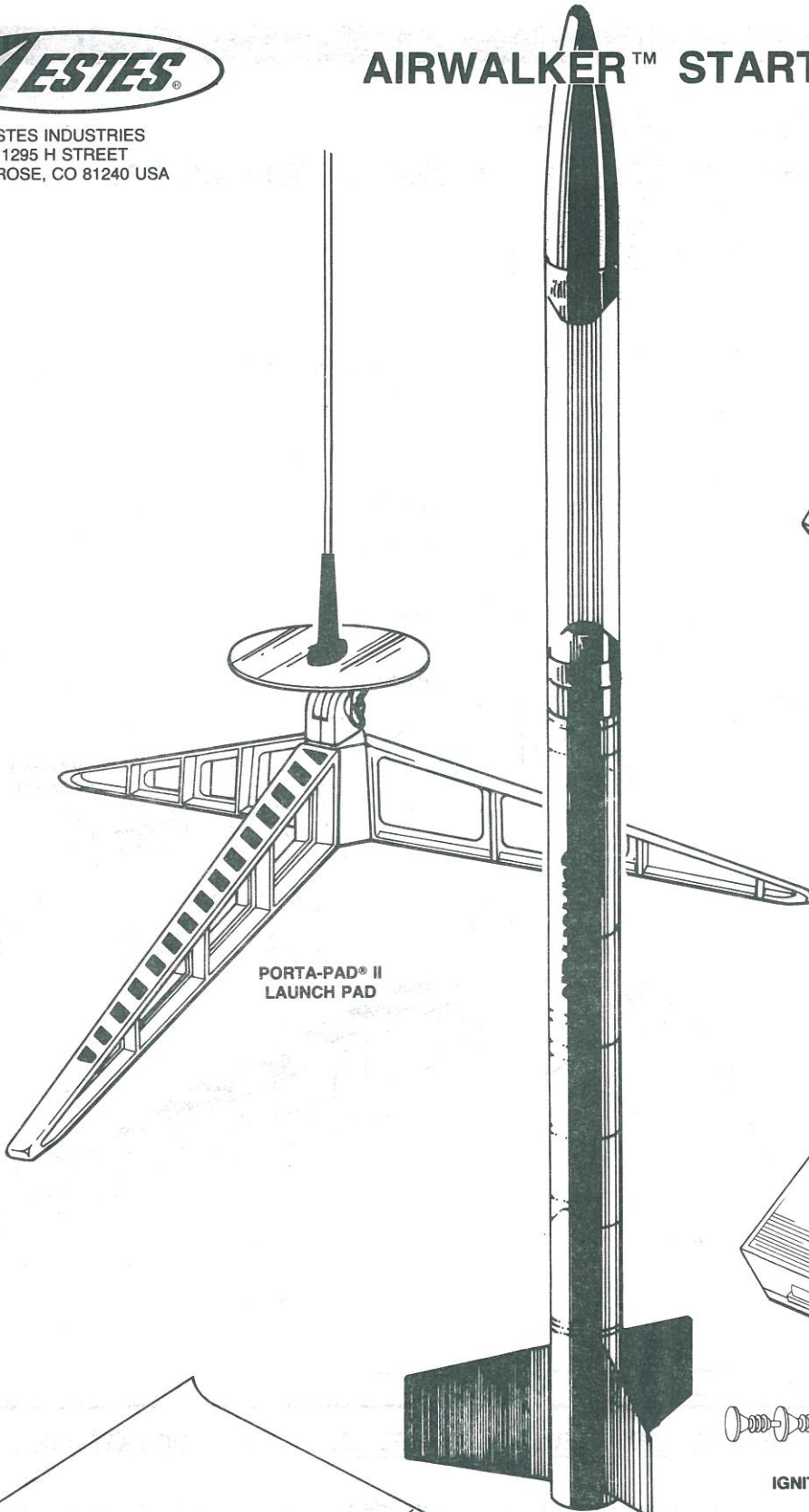

ESTES INDUSTRIES
1295 H STREET
PENROSE, CO 81240 USA

AIRWALKER™ STARTER SET

#1410



PORTA-PAD® II
LAUNCH PAD

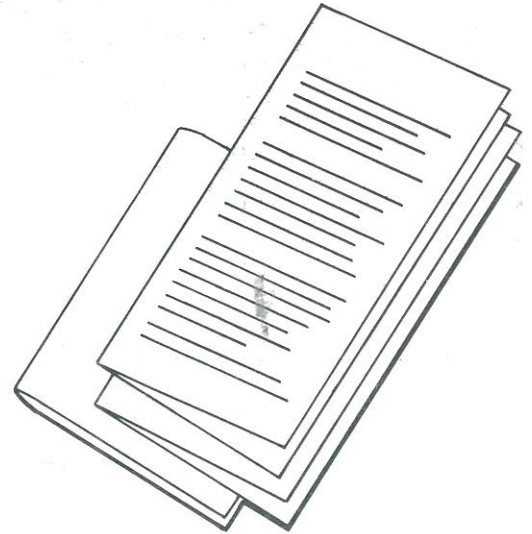

LITERATURE

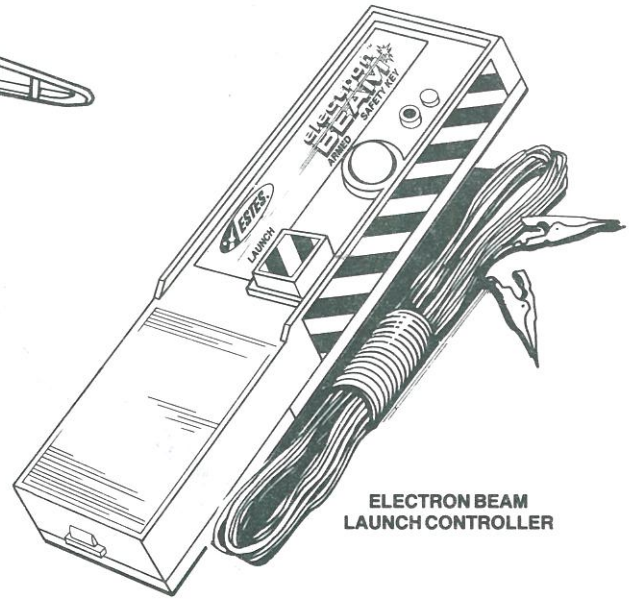

ELECTRON BEAM
LAUNCH CONTROLLER

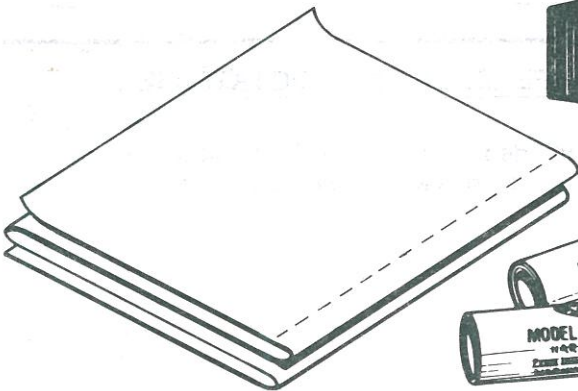

RECOVERY
WADDING

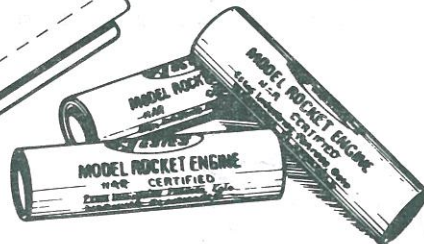

ROCKET
ENGINES



IGNITER PLUGS

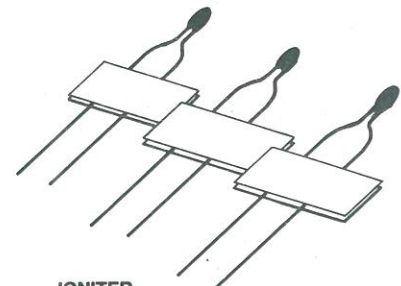

IGNITER
PACK

Part One: Launch Pad Assembly

HOW TO USE THESE INSTRUCTIONS:

READ ALL INSTRUCTIONS BEFORE STARTING WORK ON THIS MODEL

- A. Read each step first and visualize the procedure thoroughly in your mind before starting construction.
- B. Lay parts out on the table in front of you.
- C. Use exploded view to match all parts contained in kit.
- D. Collect all construction supplies that are not included in the kit.

EXPLODED VIEW

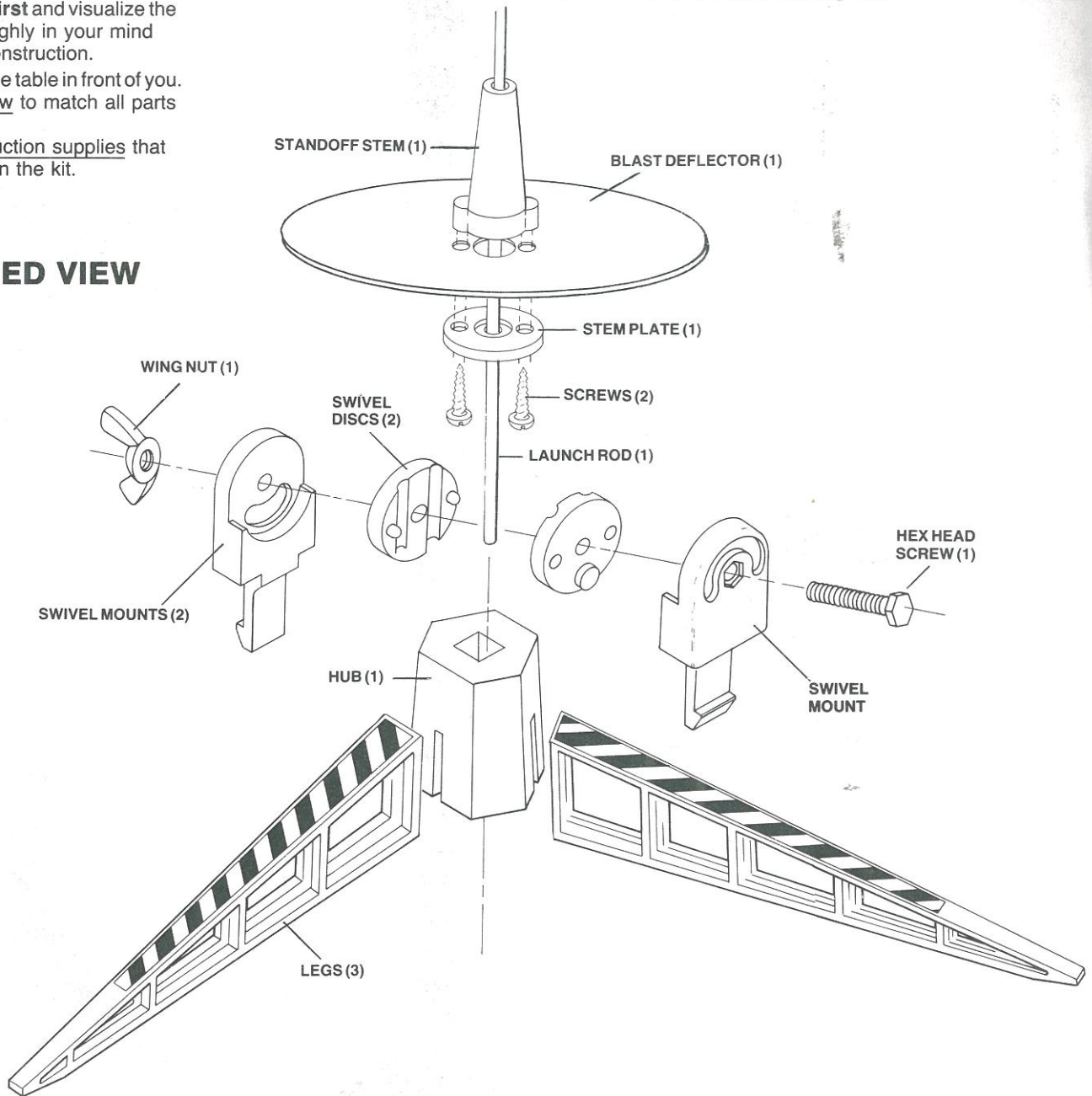

EXTREMELY IMPORTANT: THE EXPLODED VIEW IS FOR REFERENCE ONLY! DO NOT USE THIS DRAWING ALONE.

The exploded view is only intended to assist you in locating the parts included in this kit. Refer back to this exploded view as you build your pad step by step. This method will help you to put the parts into perspective as you progress through the construction.

CONSTRUCTION SUPPLIES

In addition to the parts included in your kit, you will need these construction supplies. Each step shows which supplies will be required.



SCREWDRIVER



SANDPAPER

1. LAUNCH ROD ASSEMBLY



- A. Join launch rod halves by inserting pin contained in one rod into hole contained in other rod. Do not attempt to push the pin in all the way.
- B. Hold the joined rods above a concrete floor and repeatedly drop on end until rod halves are tightly joined.
- C. Check the completed rod joint and ends for burrs. If any exist, remove them with the furnished sandpaper. It is important that the launch rod be smooth to avoid snagging a model rocket launch lug.

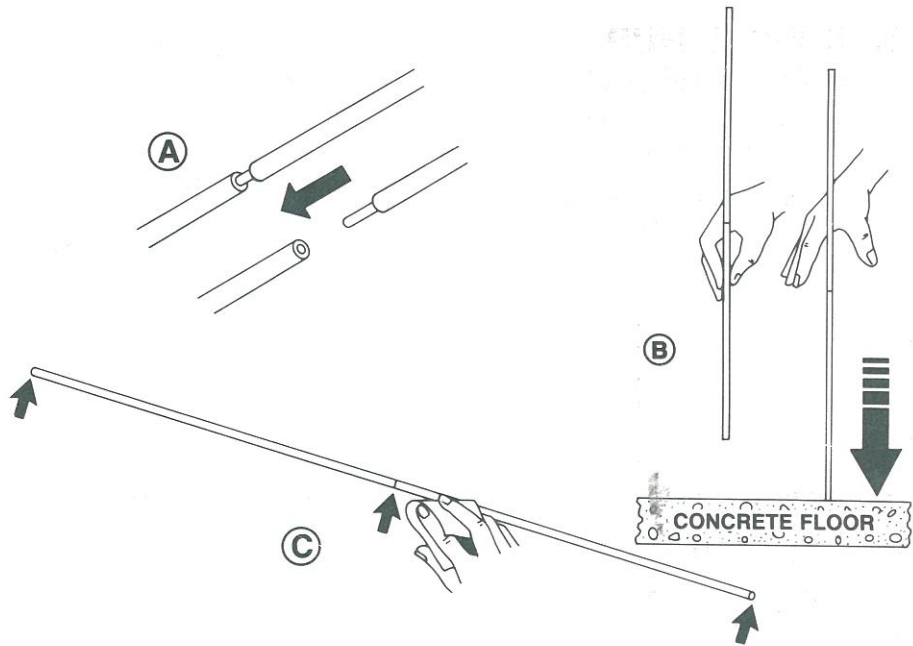

IMPORTANT

SAND JOINT AND BOTH ENDS UNTIL COMPLETELY SMOOTH

2. SAFETY KEY CAP ASSEMBLY

- A. Tie a knot in one end of elastic cord.
- B. Pass the cord through the small hole in the safety cap and tie to the controller safety key.
- C. Place the safety cap on one end of the launch rod and set aside.

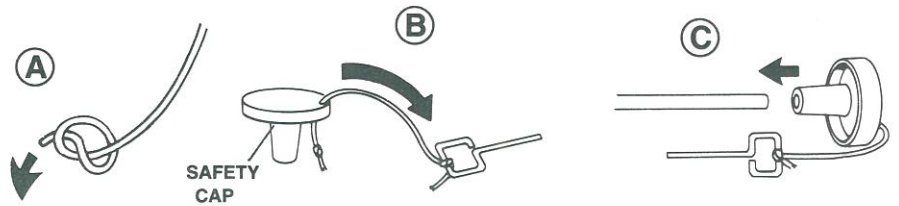

3. LAUNCH STANDOFF ASSEMBLY



- A. Set the blast deflector on the standoff stem. The collar on the bottom of the standoff stem should protrude through the deflector. Make sure the screw holes in the stem align with the screw holes in the deflector.
- B. Seat the stem plate, with the recessed screw holes facing outward, on the blast deflector. Align the holes of the stem plate with those in the blast deflector/standoff stem assembly.
- C. While ensuring that the screw holes remain aligned, carefully insert screws and tighten. **DO NOT OVERTIGHTEN!**

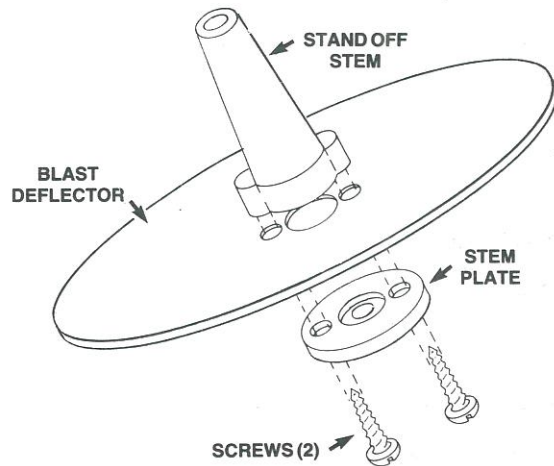

4. SWIVEL HUB ASSEMBLY

- A. Join swivel discs so that the small and large launch rod openings match.
- B. Insert hex head machine screw through central hole in one swivel mount.
- C. Slide joined swivel discs onto hex head screw. Seat circular boss on swivel disc into slot in swivel mount.
- D. Slide remaining swivel mount onto hex head screw and seat slot over circular boss.
- E. Attach and lightly tighten wing nut.

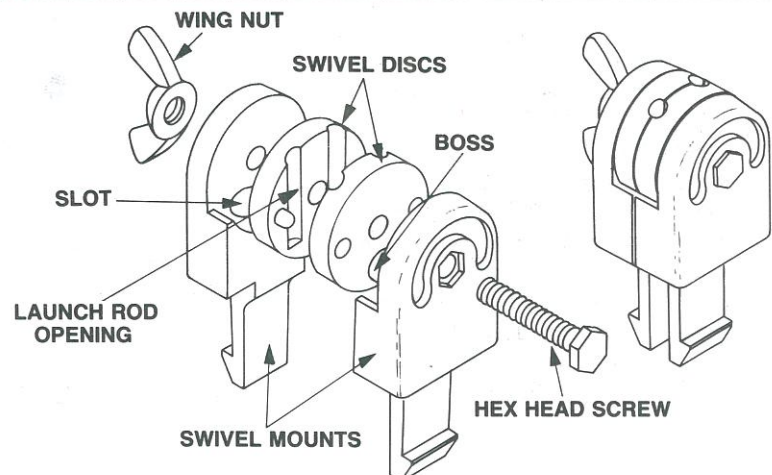

5. SWIVEL HUB ATTACHMENT

- A. Push the completed swivel hub assembly into the square opening in the top of the launch pad hub as far as it will go. It will snap in place.

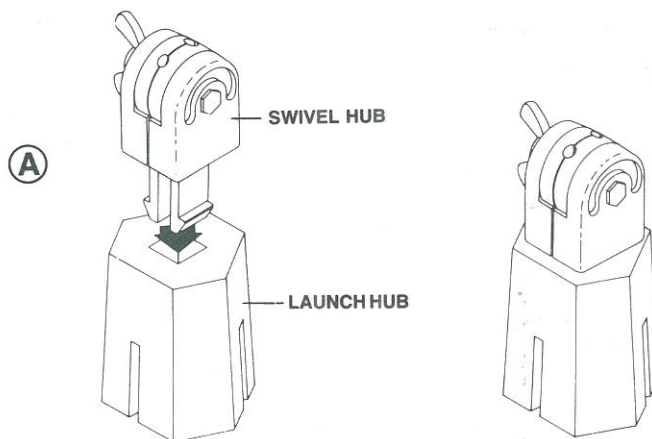

6. LAUNCH PAD LEG ASSEMBLY

- A. Attach the launch pad legs to the launch pad hub. Legs are seated properly when their tops are even with the top of the hub.

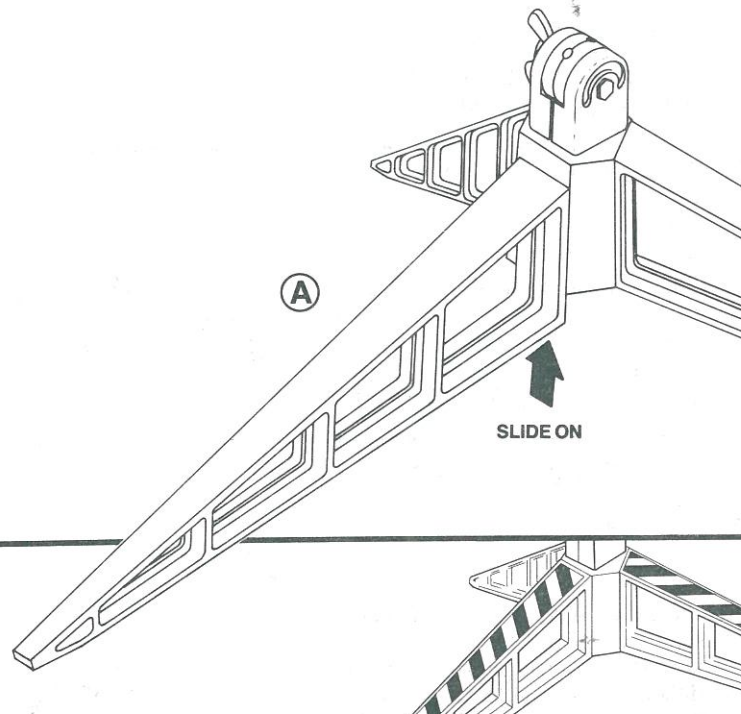

7. DECAL APPLICATION

- A. Carefully remove one decal at a time from the decal sheet.
B. Lightly position it as shown in the illustration.
C. When the decal is located properly, gently rub it down to remove bubbles and stick it securely.

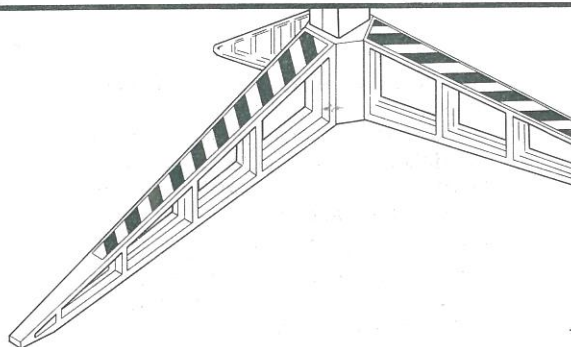

8. BLAST DEFLECTOR ATTACHMENT

- A. Insert the launch rod into the smaller 3 mm (1/8") launch rod opening between the swivel discs until it stops. (The larger 5 mm (3/16") opening is designed for Estes Maxi™ Rod launch rods.)
B. Tighten the wing nut securely.
C. Remove the safety cap from the rod end and slide the blast deflector onto the rod.
D. Replace the safety cap on the launch rod.
E. You may adjust the launch angle of your rocket in breezy conditions by loosening the wing nut and tilting the rod. Be sure to retighten the wing nut.

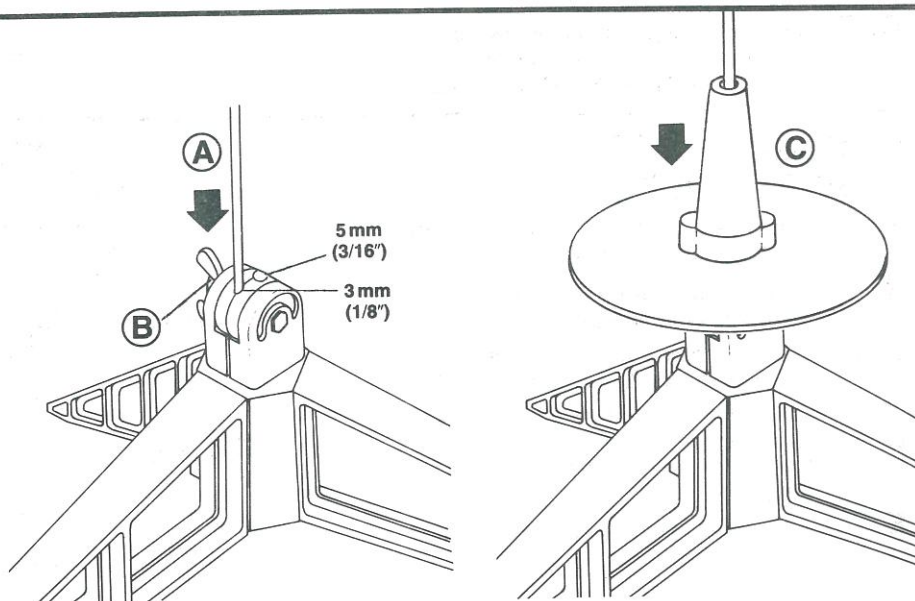

Part Two: Controller Assembly

This controller requires four AA alkaline batteries (not included). Note that only alkaline batteries are recommended.

SAFETY NOTE: This controller contains a safety key that must be inserted into the controller to arm the launch system. Follow this simple safety rule:

- A. Never insert the key into the controller until you are ready to launch.
- B. Remove the key immediately after launch or if you must return to the launch pad in case of a misfire. Always keep the safety key in your possession or place safety cap/key on launch rod.

1. BATTERY INSTALLATION

- A. Remove battery door. Push in on tab and pull down on door.
- B. Install three batteries in long compartment. Plus (+) ends of batteries must face towards rear of controller.
- C. Install remaining battery in short compartment with plus (+) end of battery facing forward.
- D. Replace battery door.

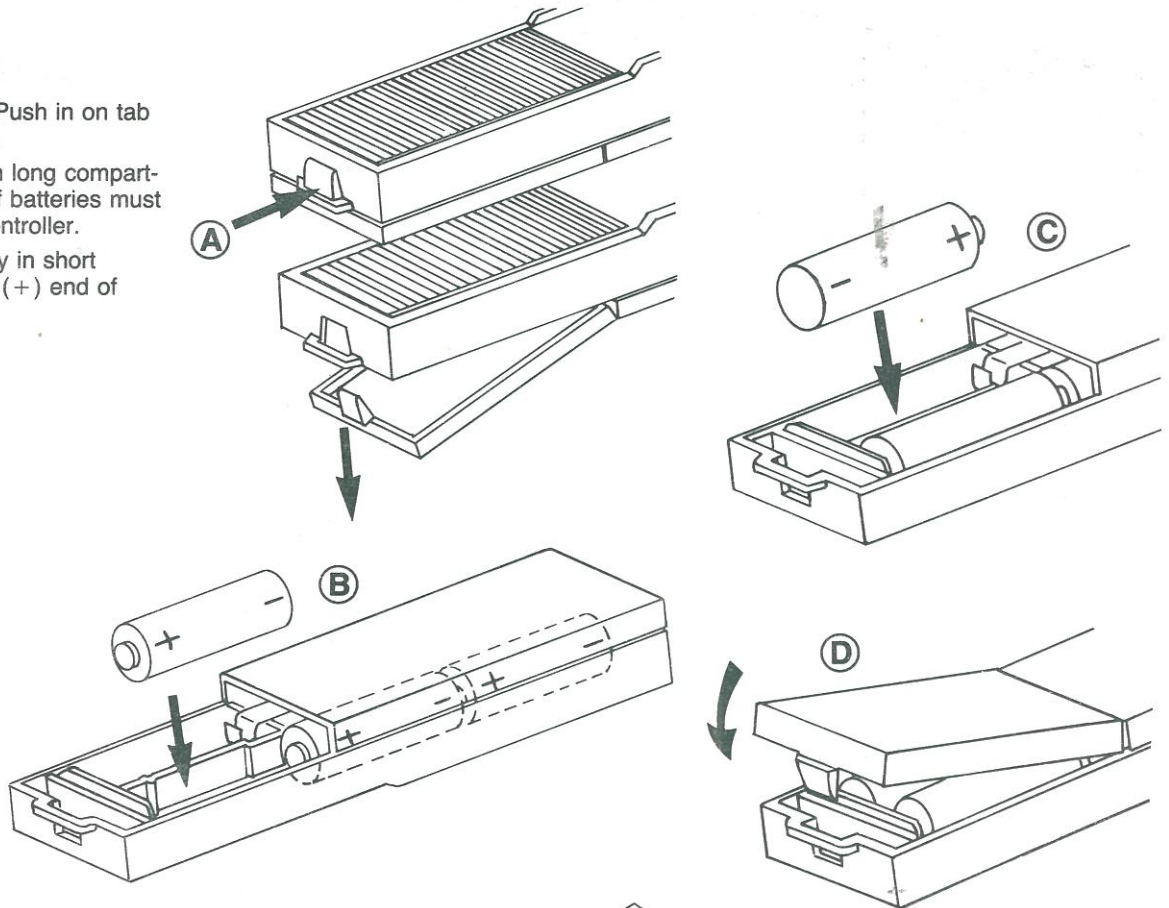

2. DECAL PLACEMENT

- A. Carefully remove one decal at a time from the decal sheet. Lightly position as shown in the illustration. When decal is located properly, gently rub it down to remove bubbles and stick it securely. Note: Be careful not to overlap launch controller body joint with the side decals.

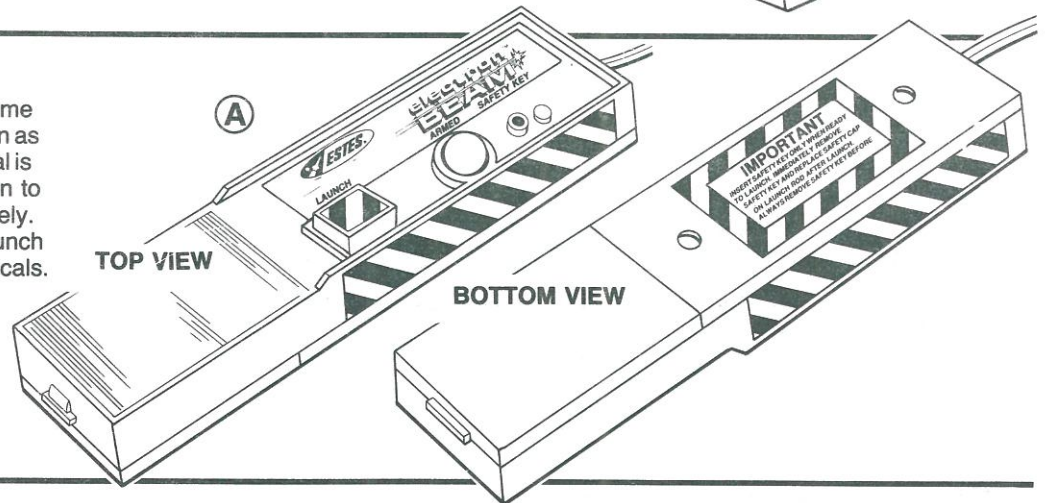

3. TEST THE CONTROLLER

- A. Clip micro-clips together.
- B. Insert safety key. This will cause the bulb to light.
- C. Press the launch button for **only a moment**. Bulb will go out while button is depressed.

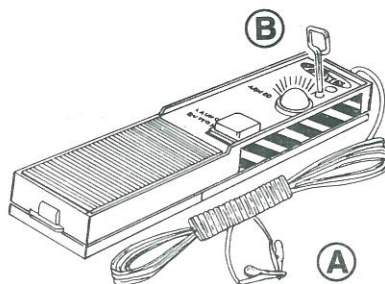

If the controller does not behave as described, check the following:

- Make sure the micro-clips are firmly clipped together.
- Remove and re-insert the safety key to insure it is making contact.
- Make sure batteries are correctly inserted as described above.

If you cannot get the controller to work, return it to Estes for replacement (see warranty on back of instructions).

Part Three: Rocket Assembly

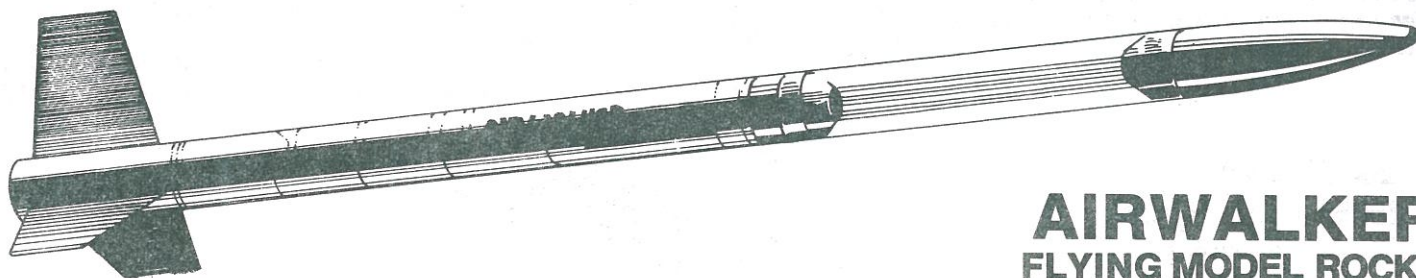

AIRWALKER™ FLYING MODEL ROCKET

HOW TO USE THESE INSTRUCTIONS:

READ ALL INSTRUCTIONS BEFORE STARTING WORK ON THIS MODEL

- A. This rocket, incorporating basic model rocketry construction techniques, will help you in the development of your rocketry modeling skills.
- B. Test fit parts before applying any glue. Trim parts as necessary for proper fit.
- C. The construction supplies required for each step are listed at the beginning of each step.

EXPLODED VIEW

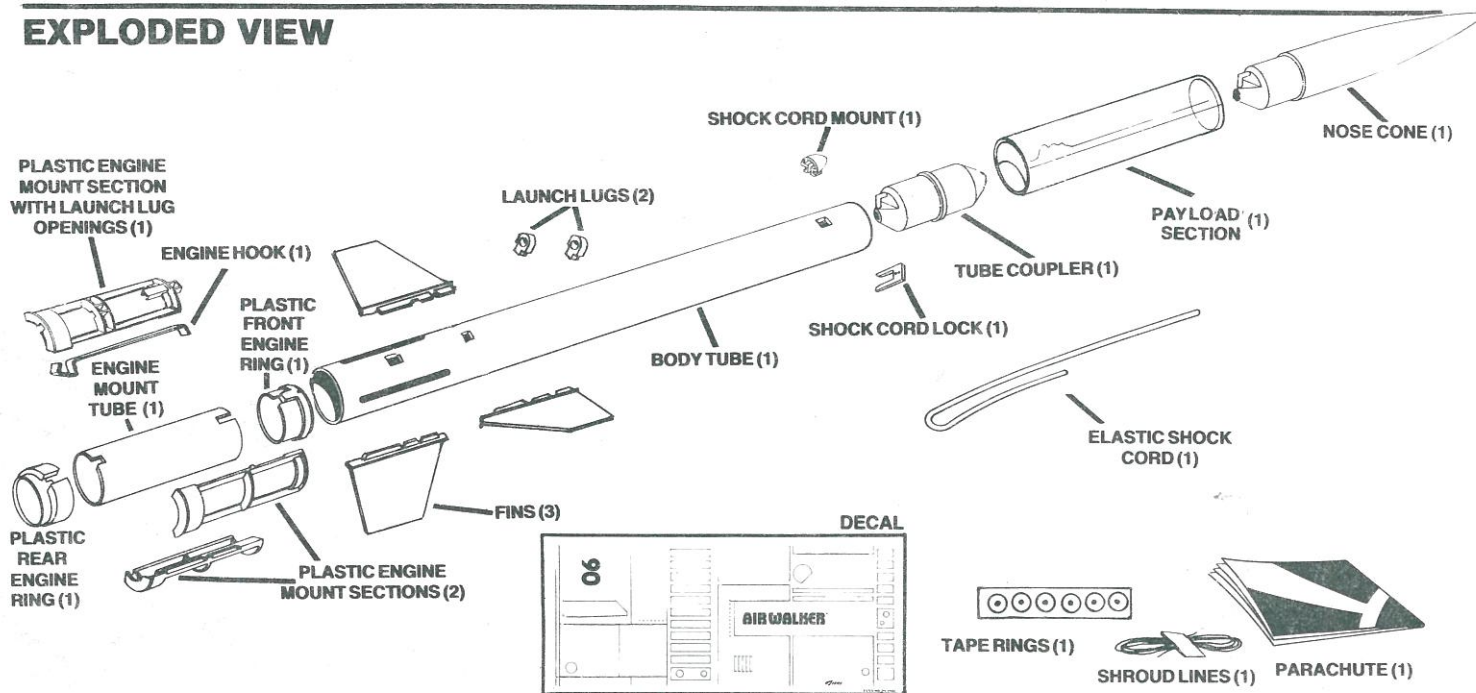

EXTREMELY IMPORTANT: THE EXPLODED VIEW IS FOR REFERENCE ONLY! DO NOT USE THIS DRAWING ALONE TO ASSEMBLE THIS MODEL.

The exploded view is only intended to assist you in locating the parts included in this kit. Refer back to this exploded view as you build your model step by step. This method will help you to put the parts into perspective as you progress through the construction.

CONSTRUCTION SUPPLIES

In addition to the parts included in your kit, you will need these construction supplies. Each step shows which supplies will be required.



SCISSORS



PLASTIC CEMENT



HOBBY KNIFE



TAPE



PENCIL

PLASTIC MODEL CEMENT IS APPLIED TO SURFACES SHOWN IN RED.

1. NOSE CONE PREPARATION



- A. Snap the tube coupler and nose cone apart as shown. Save coupler for payload section assembly.
- B. Clean off excess plastic.
- C. The hole in plastic loop may have to be cleaned out with a hobby knife.
- D. Set nose cone and coupler aside until step 5.

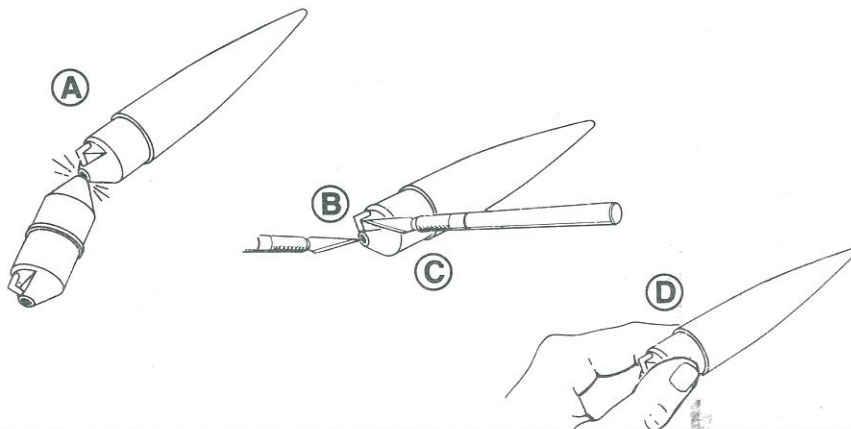

2. ENGINE MOUNT ASSEMBLY



NOTE: For this step you will need: front and rear engine mount rings, three engine mount sections, engine mount tube and engine hook. **Do not use glue yet!** Read each step, test fit all parts together first without gluing. Trim off any excess plastic to ensure proper fit.

- A. Notice the engine mount tube has a notch on each end. Position long notch to the front.
- B. The front engine ring fits **into** the end of the mount tube, the rear engine ring fits **over** the end of the tube.
- C. Using the notches for guides, position the front and rear engine rings on the engine mount tube. Check for proper fit.
- D. Position engine hook as shown with front of hook through opening between front engine ring and engine tube notch. The hook should extend through the split rear ring and beyond the rear of the engine tube.
- E. Locate the plastic engine mount section with engine hook notches and launch lug openings. Position this section directly over engine hook on engine mount. Rotate it slightly until it locks into place. Hook should move up and down in slot at rear.
- F. Test fit the remaining two sections, be sure they lock into position.
- G. The illustration shows the complete engine mount assembly.
- H. Now disassemble and work through steps A through G again, this time applying glue to the areas in red.
- I. Complete engine mount. Let dry for ten minutes before installing. This is a good time to build your parachute, step 6.

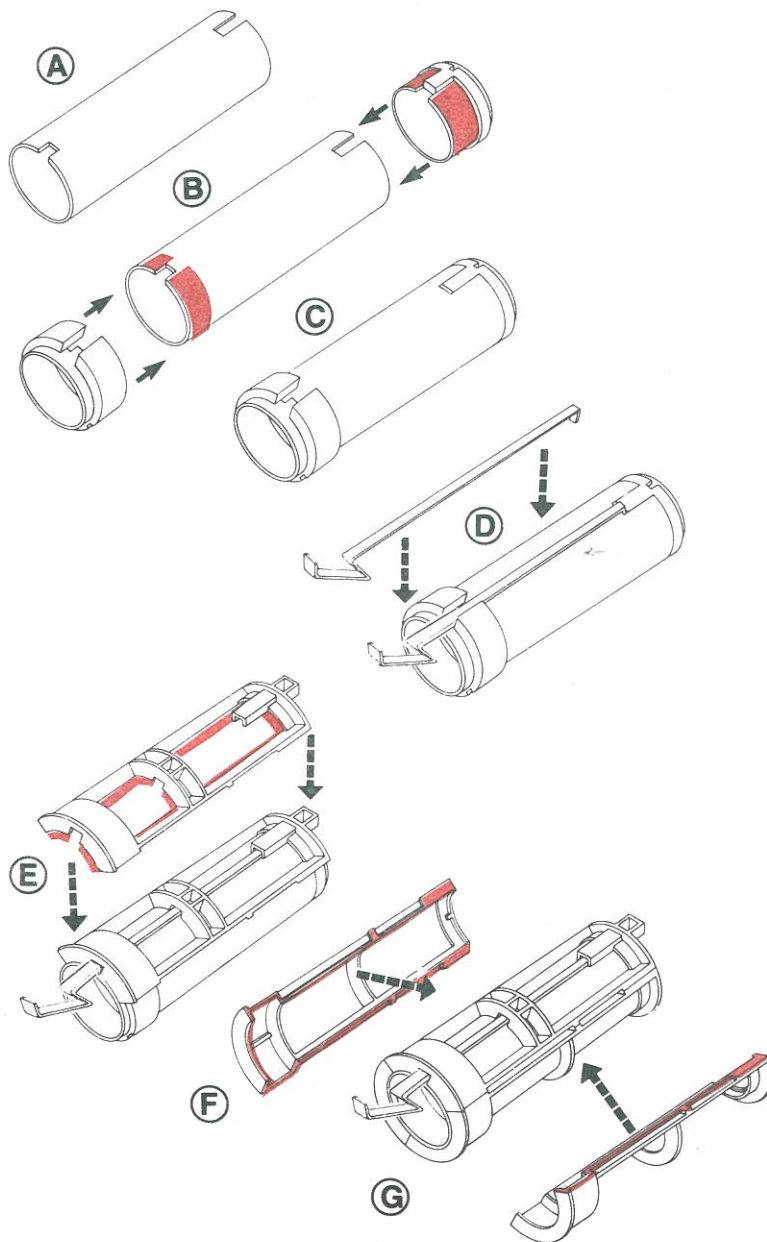

3. ENGINE MOUNT /FIN/ LAUNCH LUG INSTALLATION



- A. Locate the silver body tube. Notice the tube has three long slots and squares punched out. The slots are located at the rear of the body tube.
- B. Orient the engine mount as shown. Hold the engine hook in your fingers and gently push it into the rear of the body tube.
- C. Check for proper alignment of all three fin slots and launch lug openings.
- D. Test fit the two launch lugs into the openings as shown. Make sure holes in launch lugs go the same direction as the body tube.
- E. Test fit fins into slots. Make sure fins rest against body tube side with no gaps. Fins will fit loose at this point.
- F. Remove fins, launch lugs and engine mount. Work through steps B through E again, this time applying glue to areas in red. Put back together in proper alignment.
- G. NOTE: After gluing, check alignment on all three fin slots and launch lug openings using shade pattern at right before allowing glue to set. Allow to dry for ten minutes.

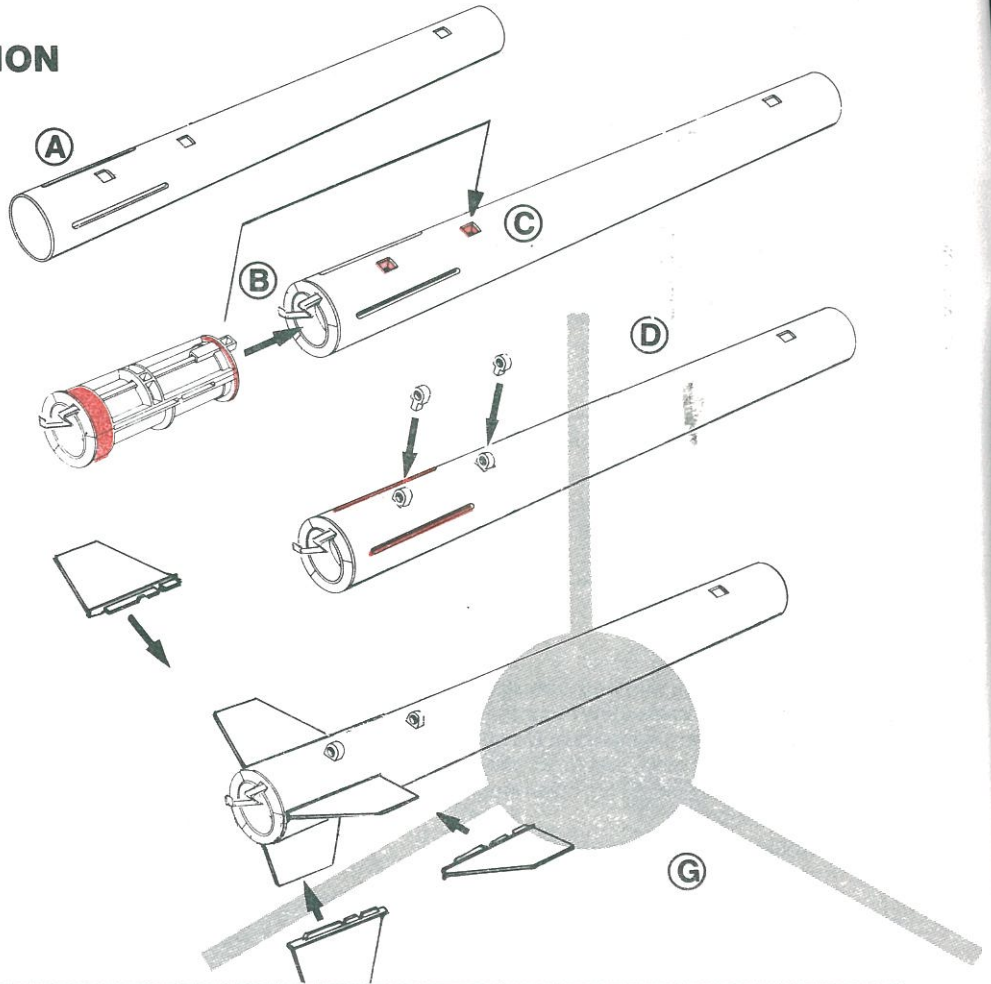

4. SHOCK CORD MOUNT ATTACHMENT



- A. Locate the shock cord mount, mount lock and elastic cord. Trim excess plastic from parts for proper fit.
- B. Insert mount into square opening in front of body tube, make sure that rounded end of mount faces forward.
- C. Locate the shock cord mount lock. The lock has the letter "I" molded in the plastic. Face the letter "I" toward inside of tube. Test fit the lock by sliding it partially under edges of mount.
- D. Remove lock, apply cement as shown and slide it back all the way up against mount.
Important: Allow glue to dry for ten minutes before proceeding to next step. Getting glue on the elastic shock cord will weaken the material which could lead to shock cord failure during flight.
- E. Tie knot in one end of the shock cord.
- F. Thread the other end of shock cord into mount from outside of tube. Feed cord through front end of body tube.
- G. Pull cord firmly and secure knot into shock cord mount as shown.

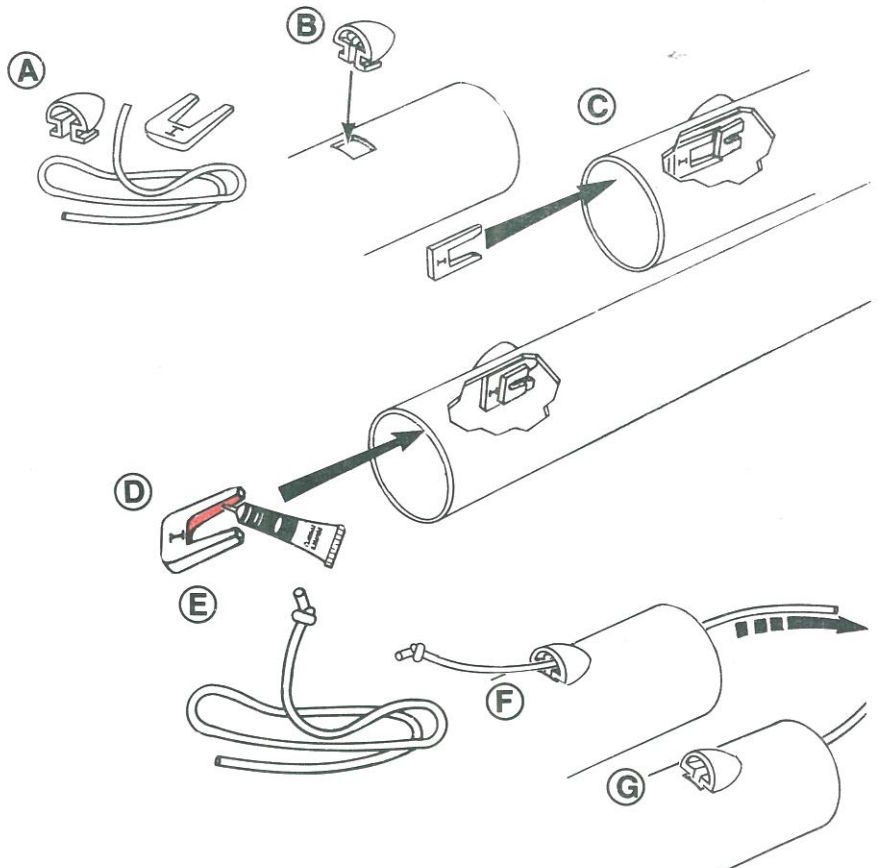

5. PAYLOAD OR BODY EXTENSION ASSEMBLY



NOTE: The forward section of your rocket can be used carry objects aloft. If you want to launch experiments in your rocket **do not glue nose cone into payload section.**

- A. Locate the tube coupler from step. 1.
- B. Clean off excess plastic. The plastic loop may have to be cleaned out with a hobby knife.
- C. Test fit the nose cone and tube coupler into payload section.
- D. CAUTION: Make sure loop on tube coupler is on the outside when assembled.
- E. Remove coupler. Use a piece of tape to shim the shoulder for a tighter fit, and put back together.
- F. If the nose cone fits loose, you may lose your payload. Use a piece of tape to shim the shoulder for tighter fit.

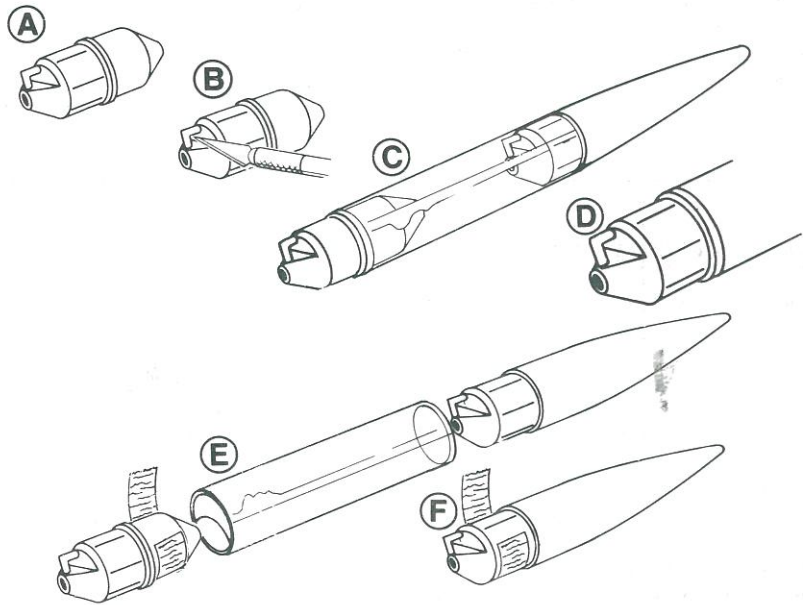

6. RECOVERY DEVICE ASSEMBLY



- A. Cut out parachute on printed edge lines.
- B. Remove tape from shroud lines, fold and cut into three equal lengths.
- C. Attach tape rings to top of parachute and press firmly into place. Punch hole through the parachute material with the point of a sharp pencil. (Do not use a dull pencil or ballpoint pen.)
- D. Pass shroud line through hole in parachute and tape ring. Tie lines together with a double knot.
- E. Attach remaining lines to other corners to complete parachute.

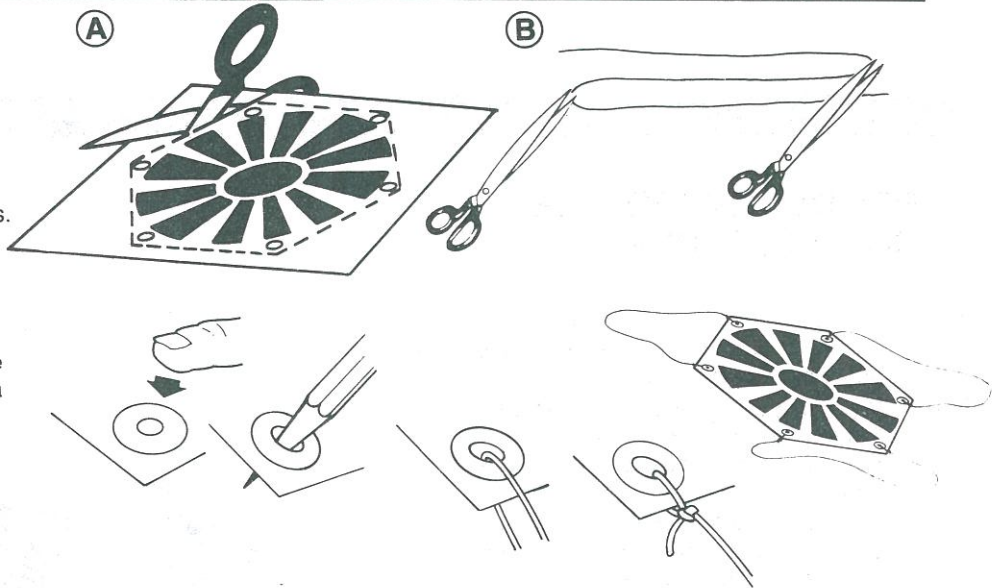

7. RECOVERY DEVICE AND SHOCK CORD ATTACHMENT

- A. Thread shroud lines through loop coupler or nose cone.
- B. Pass tip of nose cone back through loop of shroud lines as shown.
- C. Pull lines tight.
- D. Tie free end of shock cord to loop on coupler. Use a double knot.

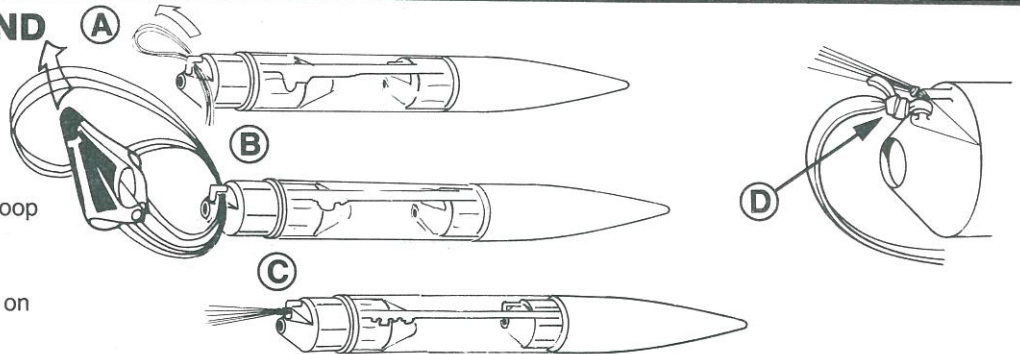

8. FINISHING YOUR ROCKET

Use the photo on the front of the box as a decal placement guide. Gently lift one decal at a time and lightly lay it down in position. If position is correct, rub it down with your finger to remove bubbles and stick it securely.

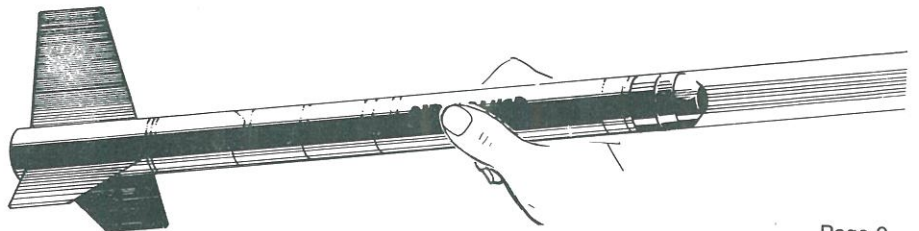

WHAT TO EXPECT WHEN FLYING YOUR AIRWALKER™ ROCKET

Your New Airwalker™ represents the latest in model rocket design and component technology. Sporting an integrated engine mount and pre-aligned fin slots, the Airwalker™ utilizes the maximum energy available from whatever recommended engine you use. No thrust is wasted. Using a C6-5, the Airwalker™ will approach 305 meters (1000 feet). If your model is loaded with a payload, expect

slightly less altitude for a given engine. Remember to "size" your field and engine properly. Fly "A" engines from baseball field size areas, "C" engines from football field size areas. At apogee (the highest point of your rocket's flight), the parachute will eject and the rocket will drift down range, the drift distance depends on the wind speed. Always keep wind conditions in mind when selecting your engine size. Enjoy flying your Airwalker™.

LAUNCH SUPPLIES

To launch your rocket you will need the following items:

- Estes Electrical Launch Controller and Launch Pad
- Estes Recovery Wadding No. 2274
- Recommended Estes Engines: 1/2A6-2, A8-3 (First Flight), A8-5, B4-4, B4-6, B6-4, B6-6, B8-5, C6-5 or C6-7

All Estes engines include igniters and igniter plugs.

To become familiar with your rocket's flight pattern, use an A8-3 engine for your first flight. **Use only Estes products to launch this rocket.**

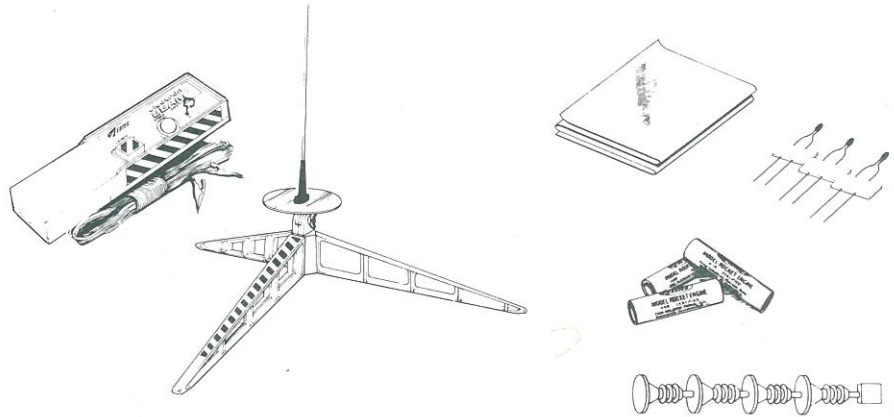

Part Four: Flight Preparation

1. RECOVERY SYSTEM INSTALLATION

- Loosely crumple three squares of recovery wadding. Insert wadding into body, but **do not** pack tightly.
- Pull 'chute into spike shape. Fold top of 'chute down, then fold **one** side over. Roll 'chute tightly and wrap shroud lines around it.
- Push shock cord and 'chute down into body and socket nose cone into place. **CAUTION:** 'Chute must slide easily into body. If it fits tightly, remove and repack 'chute.

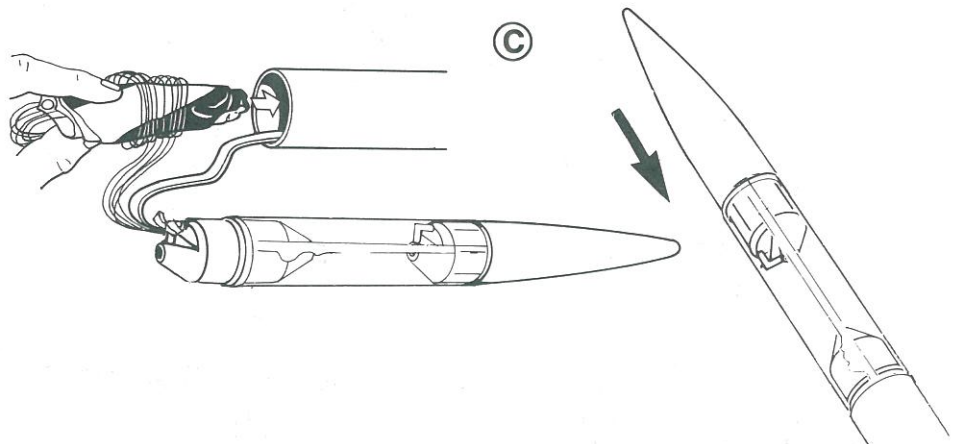
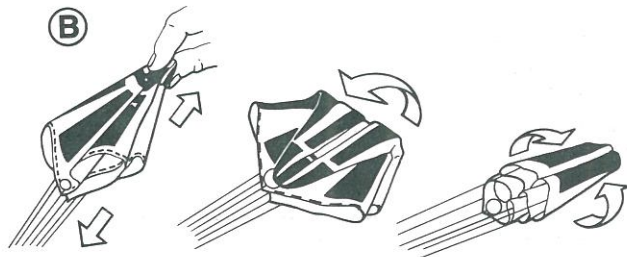
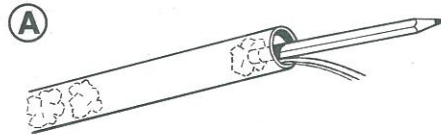

2. ENGINE/IGNITER INSTALLATION

NOTE: Always launch your model rockets by electrical means only. Our professionally engineered system uses an electrical igniter and color-coded igniter plug. The plug holds the igniter against the engine propellant so positive ignition will occur. The plug is ejected at ignition and may be recovered and used again. Follow this easy procedure to ensure reliable operation.

- A. Separate one igniter plug from its tree as shown.
- B. Carefully remove the staple holding igniters in paper. Cut one igniter from the strip as shown.
- C. Igniter will fail if wire leads touch. Gently separate wires if necessary.
- D. Hold engine upright, drop igniter into nozzle. **Note:** Igniter must touch propellant.
- E. Insert igniter plug.
- F. Firmly push the plug all the way in.
- G. Bend igniter wires into loops to allow a more positive micro-clip attachment.
- H. Push end of engine hook back and insert engine into mount tube. Hook must latch securely over end of engine to hold it in place.
- I. Your rocket is now prepared for flight. Read part five for countdown and launch.

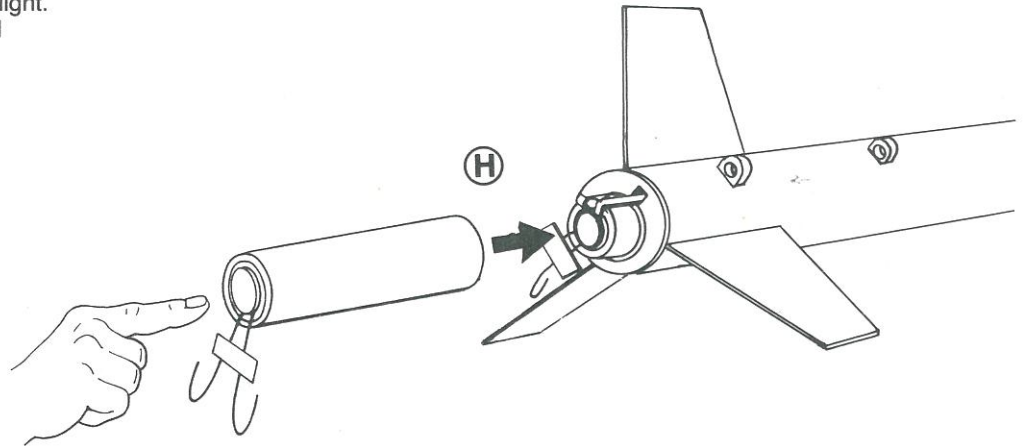
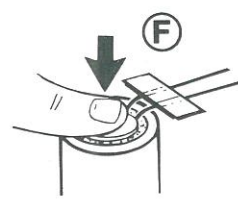
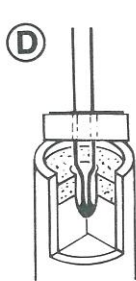
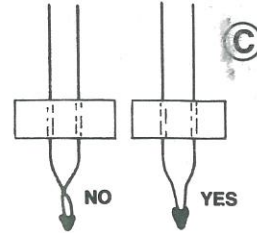
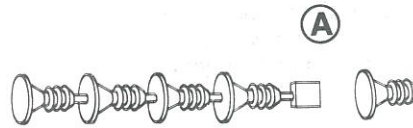

The following is a list of engine size and respective color of the igniter plug. Engines will be color-coded to match the plug color.

| Engine Type and Color | |
|-----------------------|---------|
| A3 | ORANGE |
| A10 | GREEN |
| A8; B4 | YELLOW |
| B6; C6 | MAGENTA |
| B8; C5 | BLUE |
| D12 | WHITE |

Part Five: Launch & Recovery

A. FLYING YOUR ROCKET

Set up launch pad in an open area. Choose a large field away from power lines, tall trees, and low flying aircraft. Try to find a field at least 76 meters (250 feet) square. The larger the launch area, the better your chance of recovering your rocket. Football fields and playgrounds are great.

Launch area must be free of dry weeds and brown grass.

Launch only during calm weather with little or no wind and good visibility.

Don't leave parachute packed more than a minute or so before launch during cold weather [colder than 4° Celsius (40° Fahrenheit)].

Parachute may be dusted with talcum powder to avoid sticking.

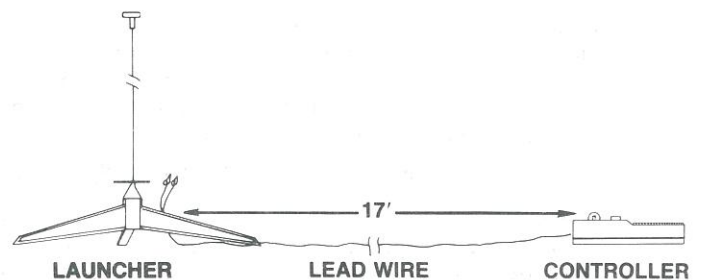

B. PAD ADJUSTMENT

Your Porta-Pad® can be adjusted by loosening and tightening of the wing nut. A rocket will always fly **into** the wind. Remember this when you adjust your pad. You may want to angle your rocket into the wind so that it drifts back to you.

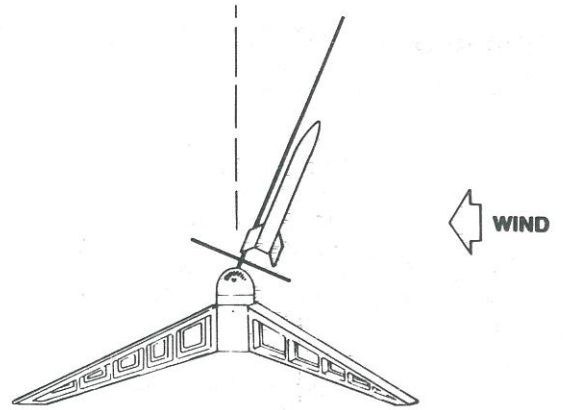

C. COUNTDOWN AND LAUNCH

- ⑩ **BE CERTAIN SAFETY KEY IS NOT IN LAUNCH CONTROLLER.**
- ⑨ Remove safety cap and slide launch lug over launch rod to place rocket on launch pad. Make sure the rocket slides freely on the launch rod.
- ⑧ Attach micro-clips to the igniter wires. Arrange the clips so they do not touch each other or the metal blast deflector. Attach clips as close to protective tape on igniter as possible.
- ⑦ Move back from your rocket as far as launch wire will permit (at least 5 meters - 15 feet).
- ⑥ **INSERT SAFETY KEY** to arm the launch controller.
Give audible countdown 5...4...3...2...1

LAUNCH!!

PUSH AND HOLD LAUNCH BUTTON UNTIL ENGINE IGNITES

SAFETY KEY MUST NOT BE IN LAUNCH CONTROLLER WHEN ATTACHING MICRO-CLIPS TO ENGINE IGNITERS

MICRO-CLIPS MUST NOT TOUCH BLAST DEFLECTOR PLATE OR EACH OTHER

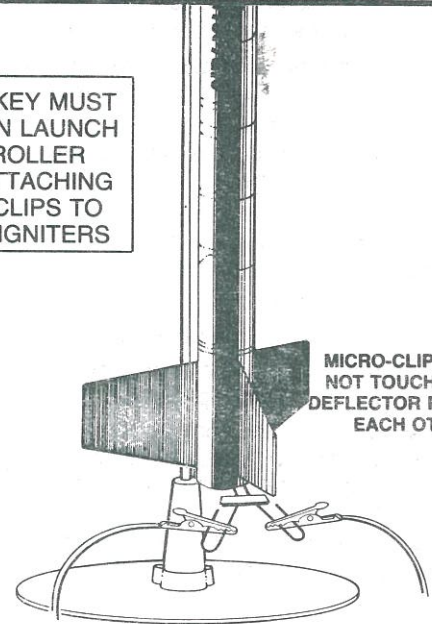

D. POST-LAUNCH SAFETY

REMOVE SAFETY KEY FROM LAUNCH CONTROLLER. KEEP KEY WITH YOU OR REPLACE SAFETY KEY AND SAFETY CAP ON LAUNCH ROD.

REMOVE SAFETY KEY...

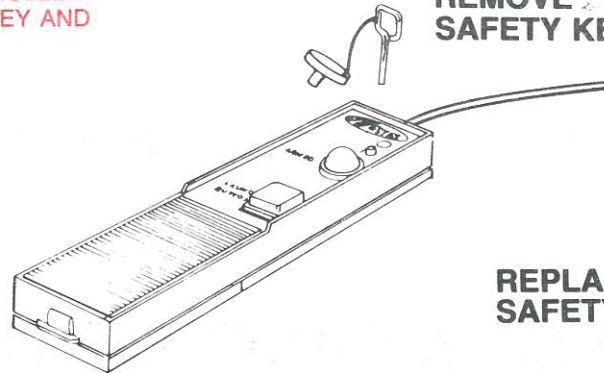

REPLACE SAFETY CAP



E. MISFIRES

If the igniter functions properly but the propellant does not ignite, keep in mind the following: An Estes igniter will function properly even if the coated tip is chipped. However, if the coated tip is not in direct contact with the engine propellant, it will only heat and not ignite the engine.

When an ignition failure occurs, remove the safety key from the launch control system and wait one minute before approaching the rocket. Remove the expended igniter from the engine and install a new one. Be certain the coated tip is in direct contact with the engine propellant, then reinstall the igniter plug. Repeat the countdown and launch procedure.

The full line of Estes products is available from most toy and hobby shops and many chain stores. Or for more information, write:

Estes Industries
P.O. 227, Penrose, CO 81240.

FOR YOUR SAFETY AND ENJOYMENT

Always follow the NAR* MODEL ROCKETRY SAFETY CODE while participating in any model rocketry activities.

*National Association of Rocketry