



BLUE SKY CLUB™

©1986 National 4-H Council

SKILL LEVEL 1 - Recommended For Beginning Rocketeers.

RECOMMENDED ENGINES:
1/2A6-2, A8-3, B4-4, B6-4, B8-5, C6-3, C6-5,
and C6-7. First Flight A8-3.

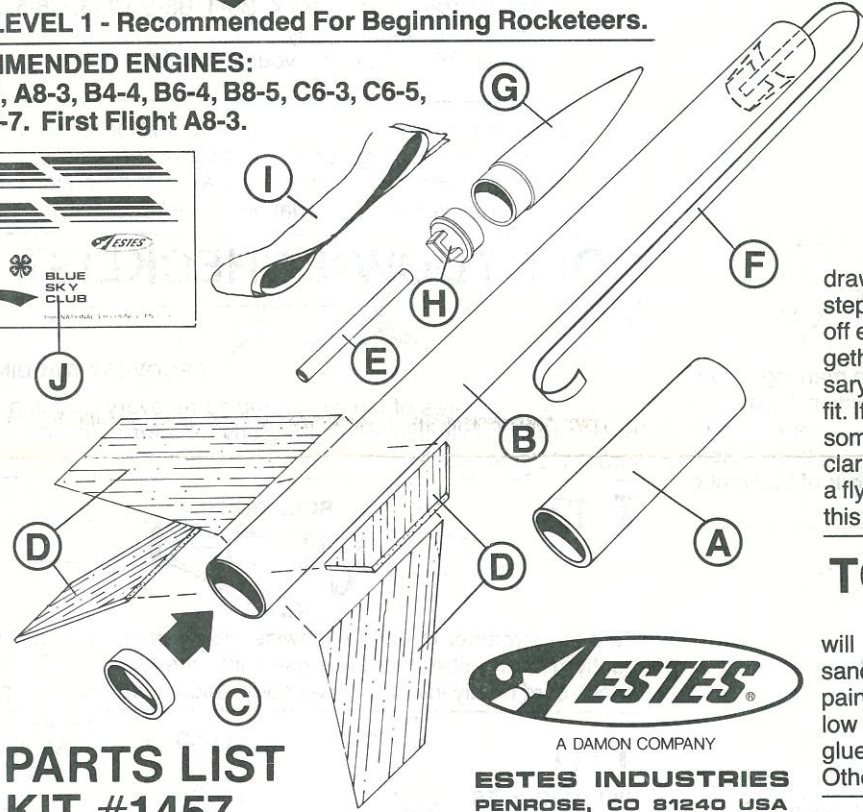
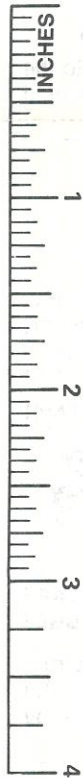
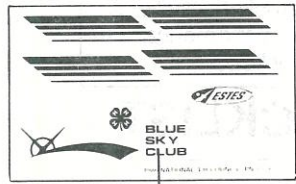

**PARTS LIST
KIT #1457**

A	1	Engine Spacer Tube (type ET-2)	35003
B	1	Body Tube (type BT-20N) 9 3/4" Long	30336
C	1	Engine Block (type AR-520)	30162
D	1	Die-Cut Balsa Sheet (type BF-0865)	32252
E	1	Launch Lug (type LL-2A)	38175
F	1	Shock Cord (type SC-1B)	85734
G	1	Nose Cone (type PNC-20A)	72602
H	1	Nose Cone Insert (type PIN-20A)	72603
I	1	Streamer (type RS-20) 18" Long	38272
J	1	Decal Sheet (type KD-1936)	37253

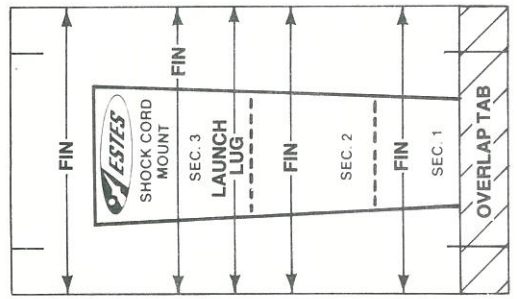
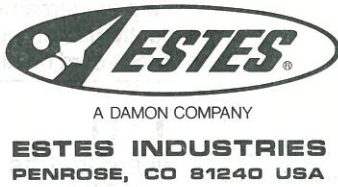

FIN MARKING GUIDE

BEFORE YOU START

Read each step and study the accompanying drawings before doing any of the work called for in that step. Make sure you have all parts and materials. Check off each step as you complete it. Always test-fit parts together before applying glue. It will sometimes be necessary to sand edges of rings, tubes, etc. to obtain proper fit. If you are in doubt about the relative size or location of some parts, refer back to this exploded view drawing for clarification. Adequate glue joints are very important for a flying model rocket. Follow the instructions carefully in this regard.

TOOLS AND MATERIALS

In addition to the parts included in this kit you will need: Scissors, pencil, ruler, fine or extra-fine grit sandpaper, sanding sealer, a medium-size modeling paint brush, modeling knife with sharp blade, gloss yellow enamel spray paint, household white glue or resin glue (Elmer's, Titebond, or similar), and plastic cement. Other types of glue are not recommended.

ASSEMBLY INSTRUCTIONS

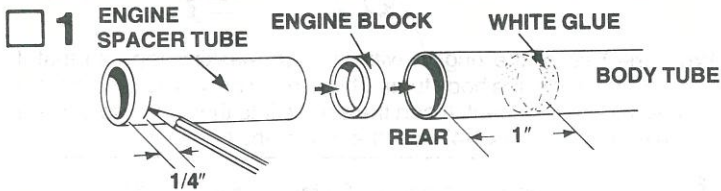

1 **ENGINE SPACER TUBE ENGINE BLOCK WHITE GLUE BODY TUBE**

Mark the engine spacer tube (part A) 1/4" from one end. Apply a band of white glue around inside of the body tube (part B) about 1" from one end. Insert the engine block (part C) into this end. Push engine block into place with the engine spacer tube until the mark on spacer is even with the end of the body tube. CAUTION: Once you have started to push the block forward, do not stop until it is in place, then IMMEDIATELY REMOVE THE SPACER TUBE.

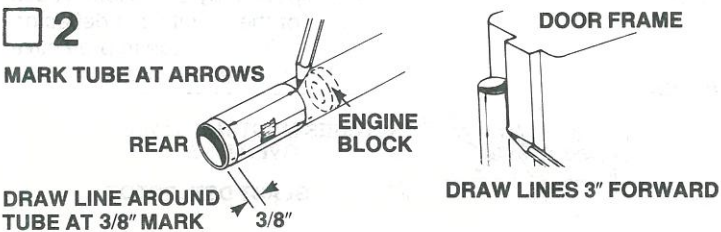

2 **MARK TUBE AT ARROWS**

Draw line around tube at 3/8" mark. Draw straight lines about 3" forward from rear of body tube, and connect each pair of marks. A door frame inside edge makes a good straight edge to extend lines.

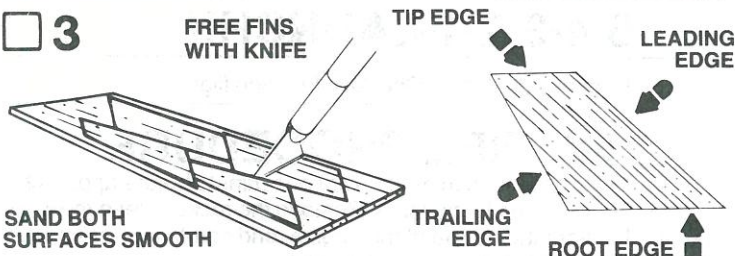

3 **FREE FIN'S WITH KNIFE SAND BOTH SURFACES SMOOTH**

Free fins (part D) with modeling knife. Be careful to make straight, clean cuts. Sand sides of fins so they are flat and smooth. Round leading and trailing edges of each fin with sandpaper. Keep root edges flat and square, if need be, lightly sand to make them square.

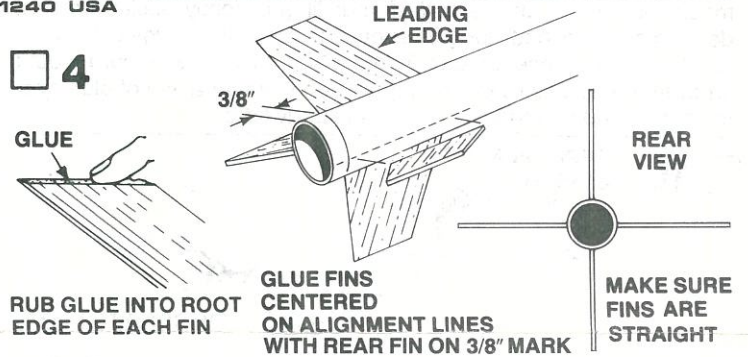

4 **RUB GLUE INTO ROOT EDGE OF EACH FIN**

Rub glue into root edge of each fin and allow to dry. Apply glue to fins again and position fins on alignment lines in positions shown. Adjust fins so they project straight away from body tube. DO NOT set rocket on fins while glue is wet.

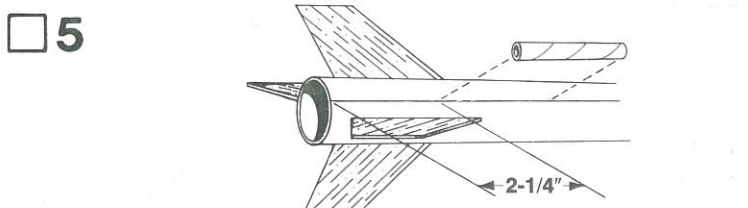

5

Glue launch lug (part E) to rocket body tube on launch lug line. Rear of launch lug should be 2-1/4" from rear of rocket body tube. Align launch lug straight along body.



6 **APPLY THIN LINE OF GLUE TO JOINT THEN SMOOTH OUT WITH FINGER**

When glue on fin joints has dried, apply a glue reinforcement to each fin/body tube joint. Holding model level, apply a line of glue to both sides of each fin joint and on both sides of the launch lug. Smooth out glue with your finger. IMPORTANT - Support rocket on table edge as shown until glue dries.

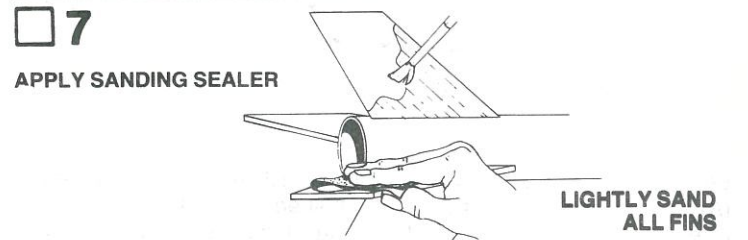

7 **APPLY SANDING SEALER LIGHTLY SAND ALL FIN'S**

Application of sanding sealer makes a rocket look better and reduces drag so that the rocket will fly higher. However, this step not essential to make a safe, attractive rocket. Apply a coat of sanding sealer to each fin. When sealer is dry, lightly sand all sealed surfaces. Repeat sealing and sanding process until balsa grain is filled and smooth.

LAUNCHING COMPONENTS

To launch your rocket you will need the following items:

- An Estes model rocket launching system
- Flame resistant recovery wadding (Estes Cat. No. 2274)
- Estes 1/2A6-2, A8-3, B4-4, B6-4, B8-5, C6-3, C6-5, and C6-7 model rocket engines only.

Use an A8-3 engine for your first flight.

Be sure to follow the HIAA-NAR* Model Rocket Safety Code when carrying out your model rocket activities.

*HIAA—Hobby Industry Association of America
*NAR—National Association of Rocketry

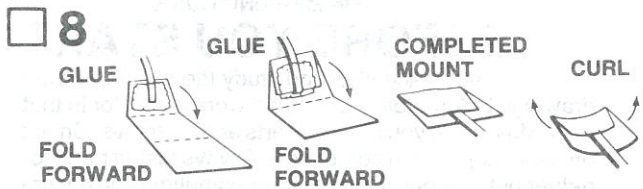

Cut out the shock cord mount from the front of the fin marking guide. Fold on dotted lines, then unfold and apply glue to section 1. Lay end of shock cord (part F) into the glue. Fold over and apply glue to back of Section 1 and exposed portion of Section 2. Fold again to complete mount. Curl edges of mount up so it will match contour of body tube and hold with your fingers until glue sets.

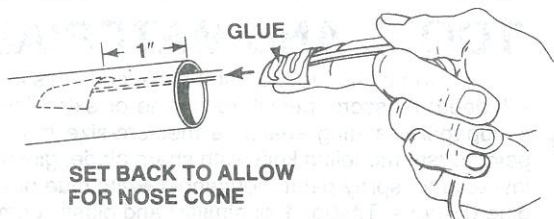

Apply glue to the back of the shock cord mount. With the shock cord mount positioned on the end of your finger, gently position mount down into front of body tube far enough from the front edge of the tube to allow for the nose cone to fit into place. Press shock cord mount firmly into position. To insure a good bond, smear a film of glue over the mount and surrounding area in the body tube.

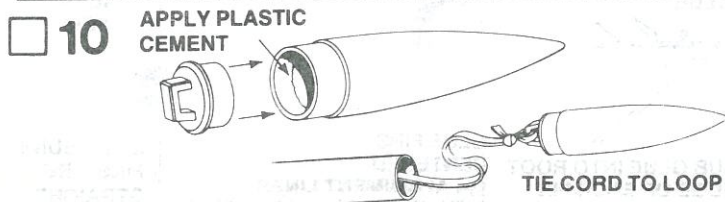

Assemble nose cone (part G) and nose cone insert (part H) with plastic cement. When cement is dry, tie free end of shock cord to nose cone loop with double knot.

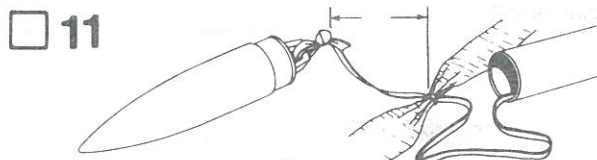

Tie the shock cord around the middle of the plastic streamer (part I) about 2" from the end of the shock cord with a double knot. Fold the streamer and roll it up until it fits into the body tube. Place the remainder of the shock cord and nose cone into the body tube.

PAINTING AND DETAILING

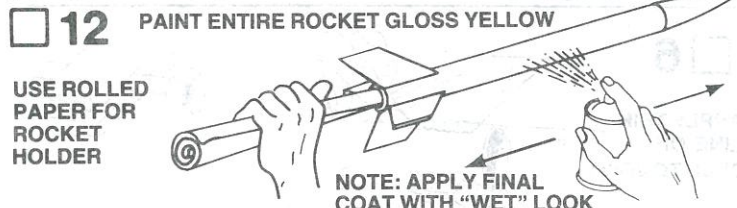

After sanding sealer is completely dry, paint entire model gloss yellow. Let this coat dry overnight. Follow instructions on spray can for best results. We recommend spray enamel. Spray model with several light coats of paint to avoid "runs".



When all paint is dry, apply the decals (part J) in the positions shown. (A) Cut only one decal at a time from sheet. (B) Submerge decal in lukewarm water until decal slides on backing paper (usually 15 to 30 seconds). (C) Gently slide decal from backing paper onto model. (D) Move decal into exact position and carefully blot away excess water with a soft cloth. (E) If the decal "sticks" before you have it in position, apply water over the decal with a brush. This will permit the decal to be moved. (F) Smooth out all wrinkles and air bubbles before the decal dries.

COUNTDOWN CHECKLIST

T-13



Pack 2 or 3 squares of loosely crumpled recovery wadding into the body tube. Usually this will fill the body tube for a distance equal to about 1½ times its diameter.

T-12

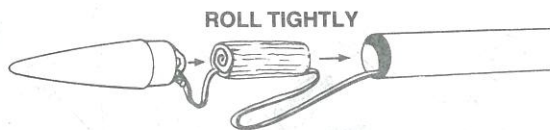

Fold the streamer in half lengthwise. Fold again, then roll streamer tightly until the streamer fits loosely into the rocket body. Pack the shock cord neatly into the rocket body. Slide nose cone into place.

T-11

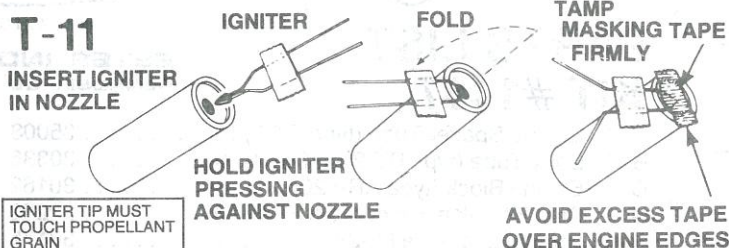

Select an engine and install an igniter as directed in the engine instructions. The engines recommended for use with this rocket are the 1/2A6-2, A8-3, B4-4, B6-4, B8-5, C6-3, C6-5, and C6-7, made by Estes.

T-10



Wrap the rear of the engine with enough masking tape so that it makes a tight fit in the body tube. This fit must be tight to obtain proper streamer deployment. Insert the engine into the rocket so the rear of the engine projects 1/4" from the rear of the body tube.

T-9 Disarm the launch panel—REMOVE SAFETY KEY!

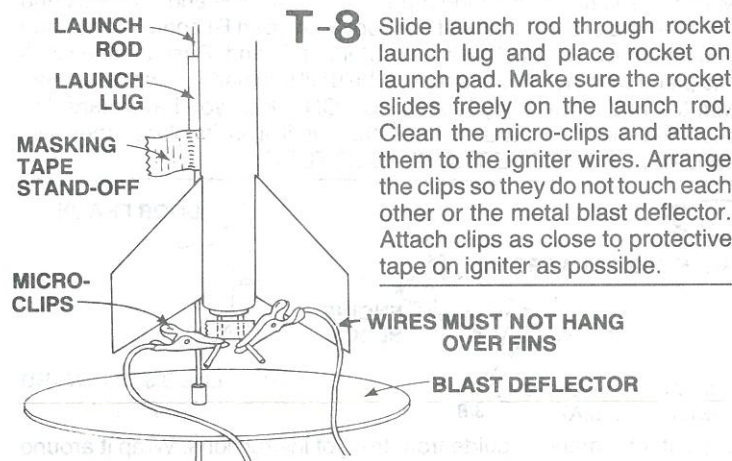

Clear the launch area. Alert recovery crew and trackers. Check for low flying aircraft and unauthorized persons in the recovery area.

Arm the launch panel—INSERT SAFETY KEY!

5-4-3-2-1-LAUNCH!!

Repeat Countdown Checklist for each flight.

MISFIRE PROCEDURE

Disarm the launch panel. Wait one minute before approaching the rocket on the launch pad. Remove the rocket, clean the igniter residue from the nozzle of the engine, and carefully install a new igniter. Repeat the Countdown Checklist.

Failure of the rocket engine to function properly is nearly always caused by a failure to install the igniter correctly. This failure permits the igniter to heat and burn into two pieces without igniting the engine.