



ESTES INDUSTRIES
1295 H STREET
PENROSE, CO 81240 USA

EX
SERIES

ScorpionTM

82129
11-96



**FLYING MODEL ROCKET KIT
EST 1472**

HOW TO USE THESE INSTRUCTIONS:

READ ALL INSTRUCTIONS BEFORE STARTING WORK ON THIS MODEL

- A. This rocket, incorporating basic model rocketry construction techniques, will help you in the development of your rocketry modeling skills.
- B. **Read each step first** and visualize the procedure thoroughly in your mind before starting construction.
- C. Lay the parts out on the table in front of you. (Check inside the tubes for any small parts.)
- D. Use parts layout to match all parts contained in the kit.
- E. Collect all construction supplies that are not included in the kit.
- F. Shock cord mount is printed in the instructions and will be found on page 4 in the patterns section.
- G. Test fit parts before applying any glue.
- H. Sand parts as necessary for proper fit.
- I. The construction supplies required for each step are listed at the beginning of each step.
- J. Check off each step as you complete it.

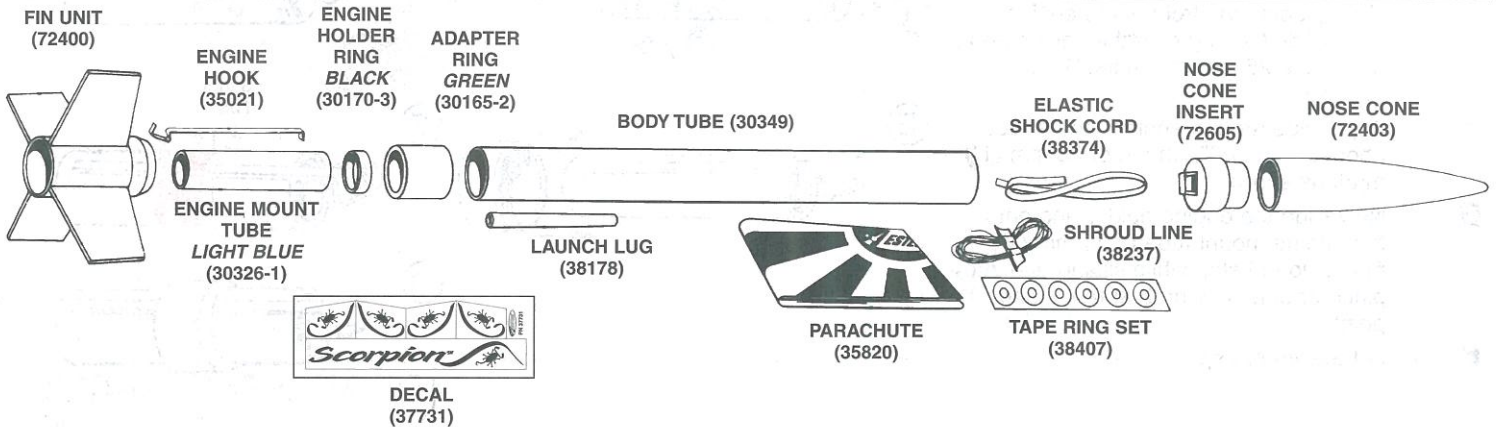

EXTREMELY IMPORTANT: THE PARTS LAYOUT IS FOR REFERENCE ONLY! DO NOT USE THIS DRAWING ALONE TO ASSEMBLE THIS MODEL.

The parts layout is only intended to assist you in locating the parts included in this kit. Refer back to this parts layout as you build your model step by step. This method will help you to put the parts into perspective as you progress through the construction.

CONSTRUCTION SUPPLIES

In addition to the parts included in your kit, you will need these construction supplies. Each step shows which supplies will be required.



PENCIL



KNIFE



GLUE
(white or yellow)



RULER



SCISSORS



PLASTIC
CEMENT

GLUE IS APPLIED TO SURFACES SHOWN IN RED.

1. NOSE CONE ASSEMBLY



- Test fit the nose cone insert into the nose cone. **Do not glue at this time.** Remove the insert.
- Apply plastic cement as shown in the illustration and re-insert. Allow assembly to dry.

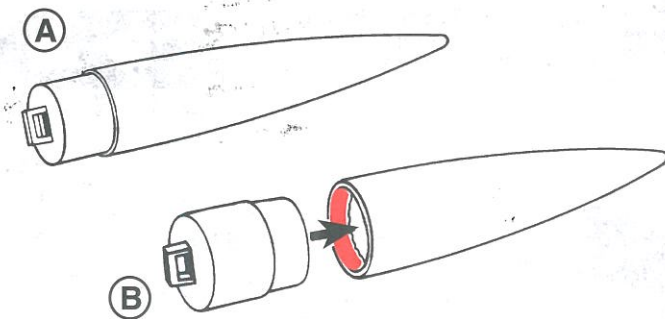

2. ENGINE MOUNT ASSEMBLY



- For this step you will need the light blue engine mount tube, the engine hook and the black engine holder ring.
- Place a mark on the engine mount tube at 25 mm (1") and 64 mm (2-1/2") from one end.
- Cut a 3 mm (1/8") wide slit at the 64 mm (2-1/2") mark.
- Insert the engine hook into the slit as shown. The engine hook should extend beyond the rear of the engine tube.
- Test fit the black engine holder ring by sliding it onto the front of the engine tube. Slide the ring over the engine hook and to the 25 mm (1") mark. Remove the ring.
- Apply glue around engine mount tube about 3 mm (1/8") ahead of 25 mm (1") mark as shown.
- Now slide the engine holder ring onto the engine mount tube to 25 mm (1") mark. Do not stop while sliding ring into place or glue may grab at the wrong point.
- Let assembly dry.

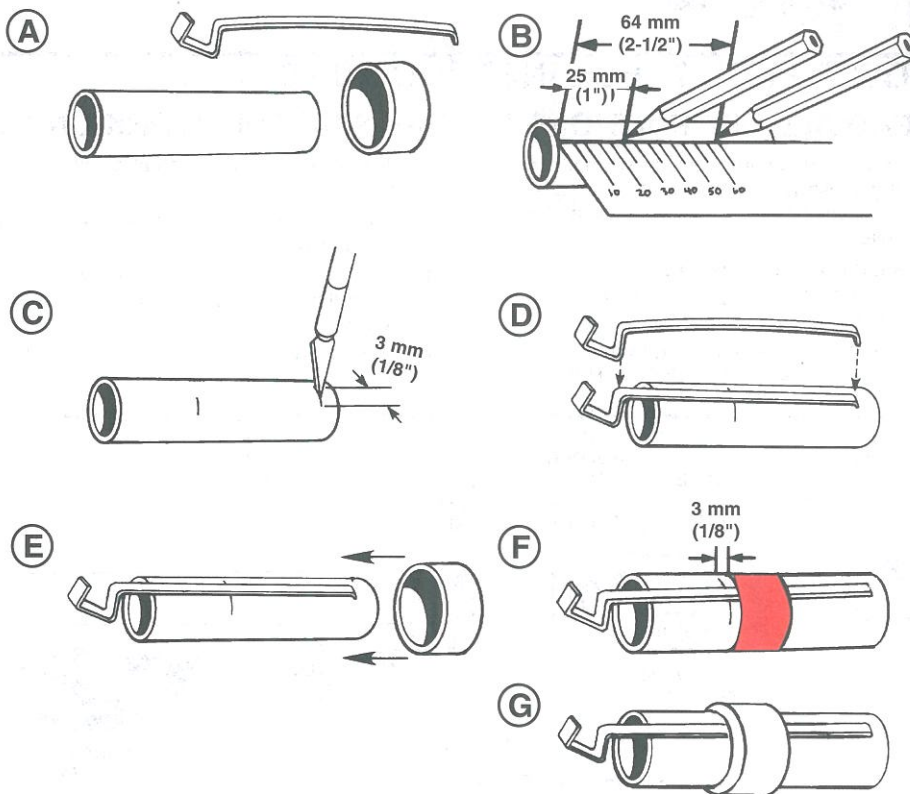

3. SHOCK CORD MOUNT ASSEMBLY



- Locate the shock cord mount below and cut out along the solid black outline.
- Crease on dotted lines by folding.
- Spread glue on section 2 and lay end of shock cord into glue at a slight angle as shown.
- Fold section 1 forward. Apply glue to section 3. Fold forward again.
- Clamp firmly with your fingers until glue dries.

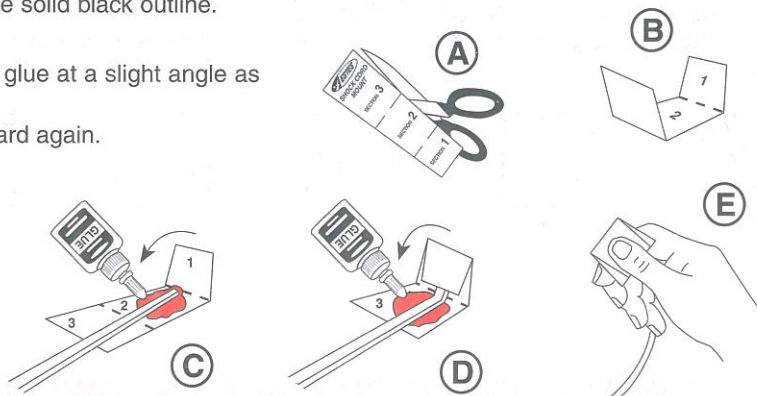
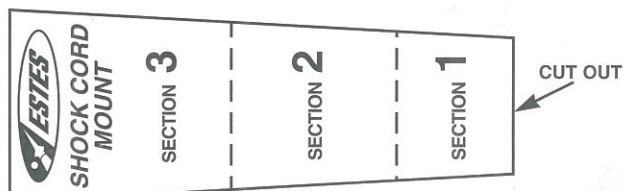

4. FIN UNIT ASSEMBLY



- Locate slot on inside of fin unit. The engine hook on the engine mount tube will fit into slot in fin unit.
- Slide engine mount assembly into plastic fin unit from the rear until the rear edges are even and the engine hook is positioned between two fins.
- Measure approximately 10 mm (3/8") ahead of fin unit and apply glue around the engine tube as shown.
- Hold engine mount tube in place and in one continuous movement, slide green adapter ring onto engine mount until it touches the fin unit evenly all around.

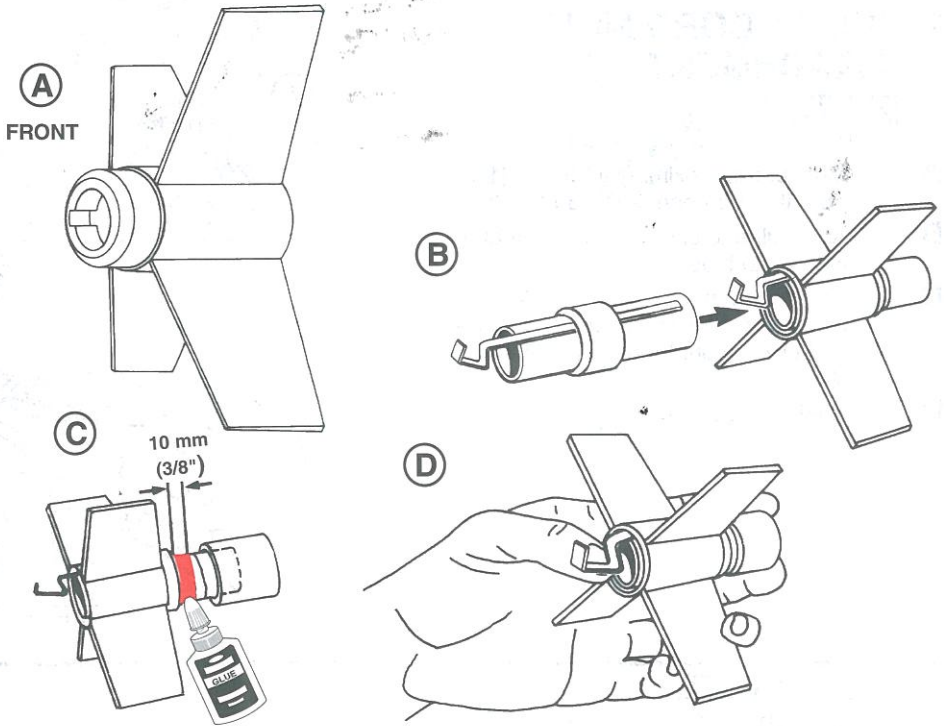

5. FIN ATTACHMENT



- Using a door frame as a guide, lightly draw a straight line along entire length of body tube as shown.
- Apply glue around inside of body tube at about 13 mm (1/2"). Add a thin layer of plastic cement to the shoulder of the fin unit.
- Align the line on body tube with the engine hook** and in one continuous motion, push the body tube over the adapter ring until tube is snug at top edge of fin unit.
- Immediately wipe away any excess cement.

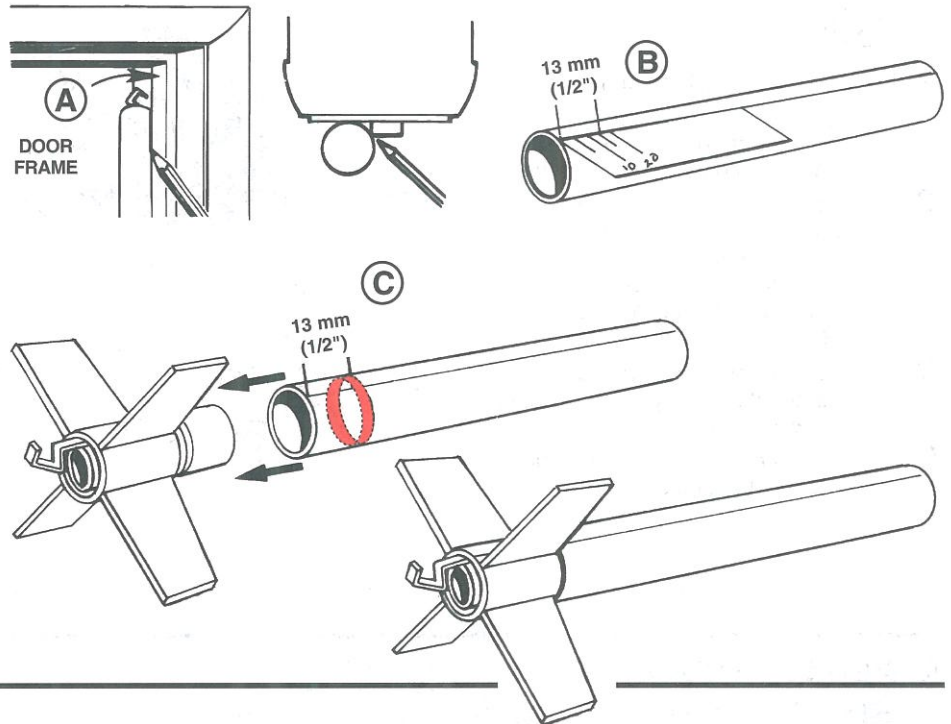

6. LAUNCH LUG ATTACHMENT



- Measure approximately 25 mm (1") from front of fin unit along the line you drew in step 5. Place a mark at this point.
- Scrape color off the body tube in launch lug attachment location. Apply glue to the launch lug and attach it to the body tube at the 25 mm (1") mark. Sight along tube to be sure launch lug is straight with body.
- After glue is dry, erase pencil line still showing on tube.

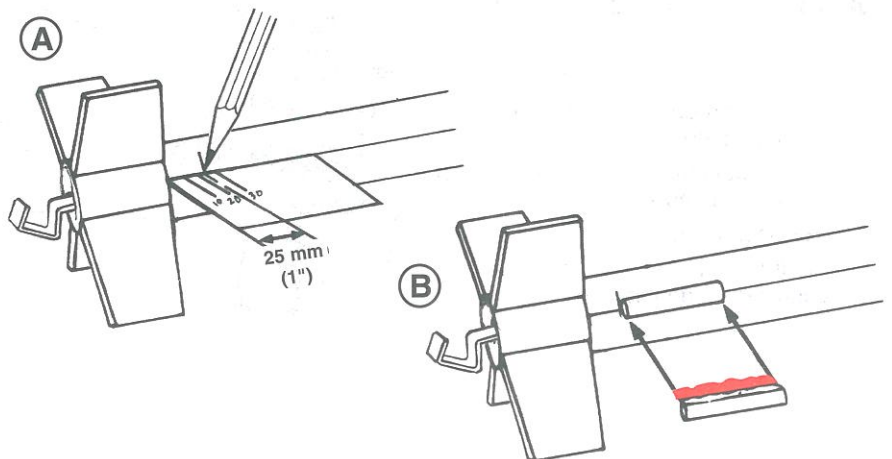

7. SHOCK CORD MOUNT ATTACHMENT



- Measure approximately 25 mm (1") from the front end of the body tube.
- Apply glue to shock cord mount and insert into tube.
- Set the mount back at least 25 mm (1") to allow for nose cone clearance and press mount firmly into glue as shown.
- Hold until glue sets.

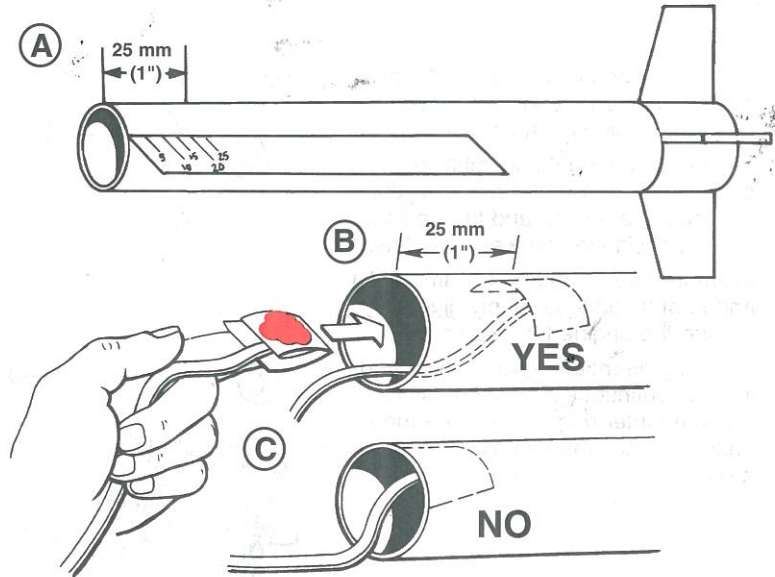

8. PARACHUTE ASSEMBLY



- Cut out parachute on printed edge lines.
- Remove tape from shroud lines, fold and cut into three equal lengths.
- Attach tape rings to top of parachute and press firmly into place. Punch hole through the parachute material with the point of a sharp pencil. (Do not use a dull pencil or ballpoint pen).
- Pass shroud line through hole in parachute and tape ring. Tie lines off with a double knot.
- Attach remaining lines to other corners to complete parachute.

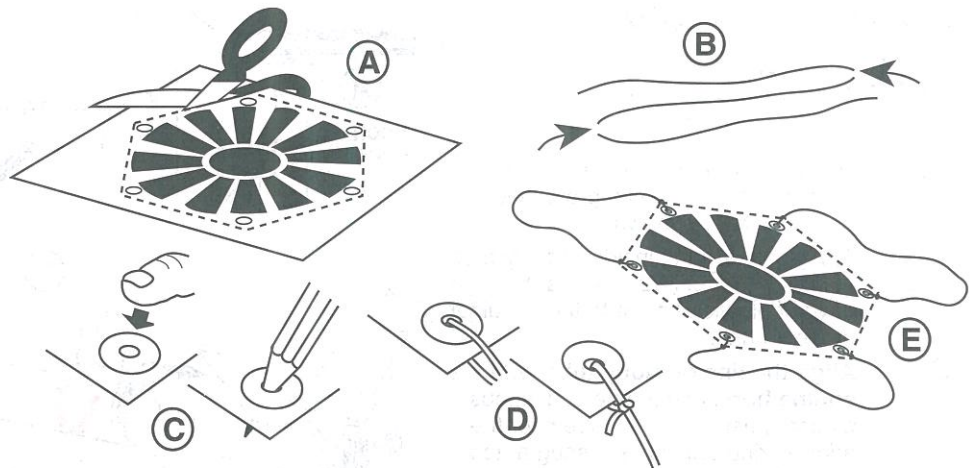

9. PARACHUTE AND SHOCK CORD ATTACHMENT TO NOSE CONE

- Thread shroud lines through eyelet on nose cone.
- Pass parachute back through loop of shroud lines as shown.
- Pull lines tight.
- Tie free end of shock cord to nose cone. Use a double knot.

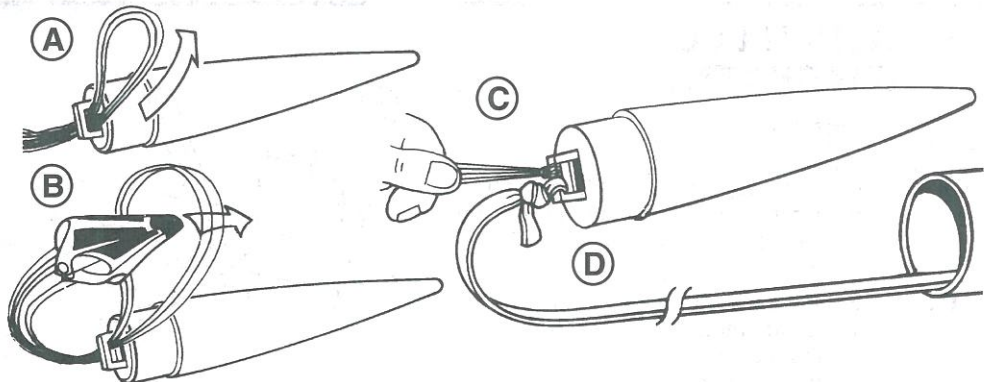

10. FINISHING YOUR ROCKET

(11-96) 82143

Remove decals from backing sheet one at a time and apply. Refer to panel art for decal location. When positioned correctly, rub down to remove air bubbles.

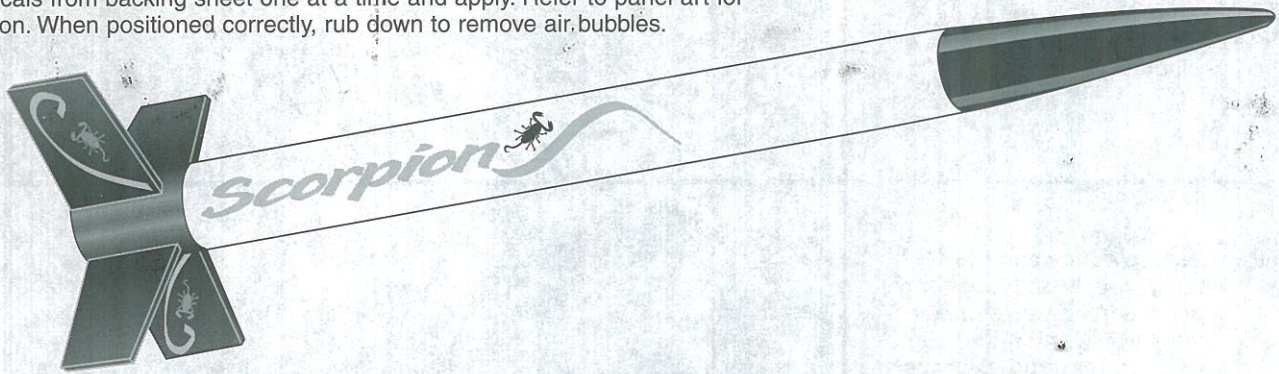

WHAT TO EXPECT WHEN FLYING YOUR SCORPION™

The Scorpion™ is a perfect beginners' rocket. The different engines that are suggested for this kit will give you a wide range of performances. The A8-3 (recommended for the first flight) will put your rocket up to 76-91 meters (250-300 feet) and the B6-4 should give you about 152-168 meters (500-550 feet) of altitude. Your Scorpion™ is capable of using a C6-5. On a C6-5, you can expect nearly 305 meters (1000 feet) of altitude. Remember to "size" your

engine for the fields in which you are flying. "A" engines are ideal for baseball diamond-size fields. A "C" engine may require an area twice the size of a football field. At apogee (the highest point of your rocket's flight), the parachute will eject. If it is breezy, remember to fly only in less than 32 kph (20 mph) wind. Your rocket may drift, so keep this in mind when you decide which engine to use. Enjoy flying your Scorpion™.

ROCKET PREFLIGHT

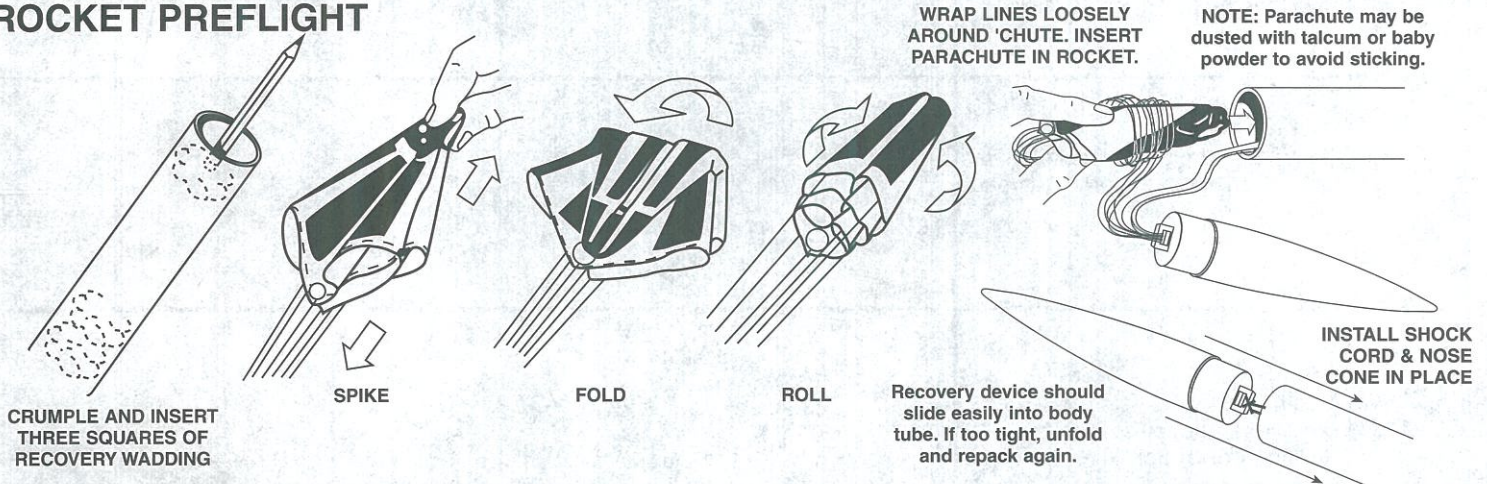

ENGINE PREPARATION

SEPARATE IGNITER AND IGNITER PLUG



HOLD ENGINE UPRIGHT, DROP IN IGNITER

IGNITER MUST TOUCH PROPELLANT

INSERT IGNITER PLUG

FIRMLY PUSH ALL THE WAY IN

BEND IGNITER WIRES BACK

INSERT ENGINE INTO ROCKET

LAUNCH SUPPLIES

To launch your rocket, you will need the following:

- Launch Pad (Estes Porta-Pad® II)
- Launch Controller (Estes Electron Beam®)
- Recommended Estes Engines: A8-3 (First Flight), 1/2A6-2, B4-4, B6-4, B6-6, C6-5, or C6-7. For your first flight, use an A8-3 engine.
- Recovery Wadding, Igniters and Igniter Plugs (included with Estes engines)

Use only Estes products to launch this rocket.

TIPS FOR FLYING YOUR ROCKET

- Choose a large field away from power lines, tall trees, and low flying aircraft. Try to find a field at least 76 meters (250 feet) square. The larger the launch area, the better your chance of recovering your rocket.
- Launch area must be free of dry weeds and brown grass.
- Launch only during calm weather with little or no wind and good visibility.
- Don't leave parachute packed more than a minute or so before launch during cold weather (colder than 4° Celsius [40° Fahrenheit]). Parachute may be dusted with talcum or baby powder to avoid sticking.
- **Always follow the National Association of Rocketry (NAR) MODEL ROCKETRY SAFETY CODE while participating in any model rocketry activities.**

COUNTDOWN AND LAUNCH

10... Safety key must not be in launch controller yet.



9... Remove safety cap from launch rod, slide launch lug over rod. Make sure rocket slides freely and micro-clips are clean for good electrical contact.

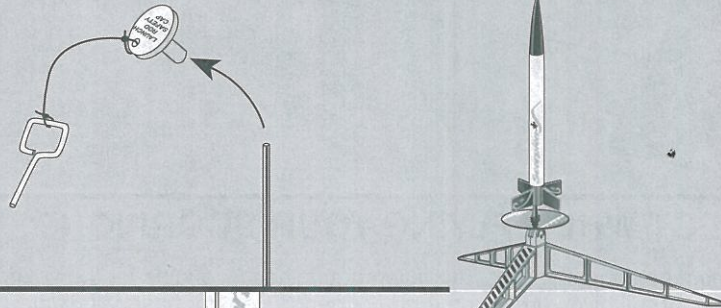

8... Attach micro-clips to the igniter wires. Arrange the clips so they do not touch each other or the metal blast deflector. Attach clips as close to protective tape on igniter as possible.

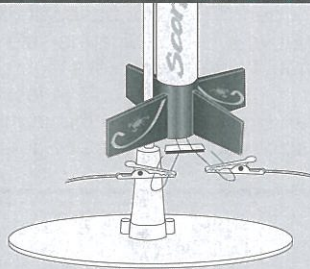

7... Move back from your rocket as far as launch wire will permit (at least five meters - 15 feet).

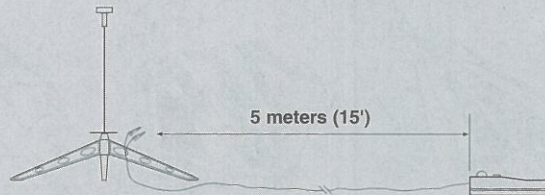

6... Insert safety key to arm the launch controller.

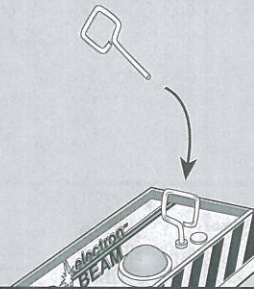

5... Start audible countdown.

4...3...2...1.....

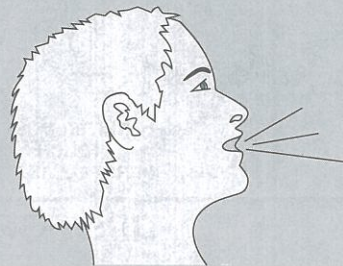

LAUNCH!

Push and hold button until engine ignites.

FOR SAFETY, IMMEDIATELY AFTER THE LAUNCH, REMOVE SAFETY KEY FROM LAUNCH CONTROLLER AND REPLACE SAFETY CAP ON LAUNCH ROD.

MISFIRES

If the igniter functions properly but the propellant does not ignite, keep in mind the following: An Estes igniter will function properly even if the coated tip is chipped. However, if the coated tip is not in direct contact with the engine propellant, it will only heat and not ignite the engine.

When an ignition failure occurs, **remove the safety key** from the launch control system and **wait one minute before approaching the rocket**. Remove the expended igniter from the engine and install a new one. Be certain the coated tip is in direct contact with the engine propellant, then reinstall the igniter plug as illustrated. Repeat the countdown and launch procedure.