



ESTES INDUSTRIES
PENROSE, CO 81240 USA

A DAMON COMPANY

TITAN II

SKILL LEVEL 2:
Recommended for
Intermediate Rocketeers

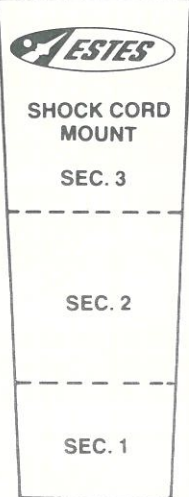
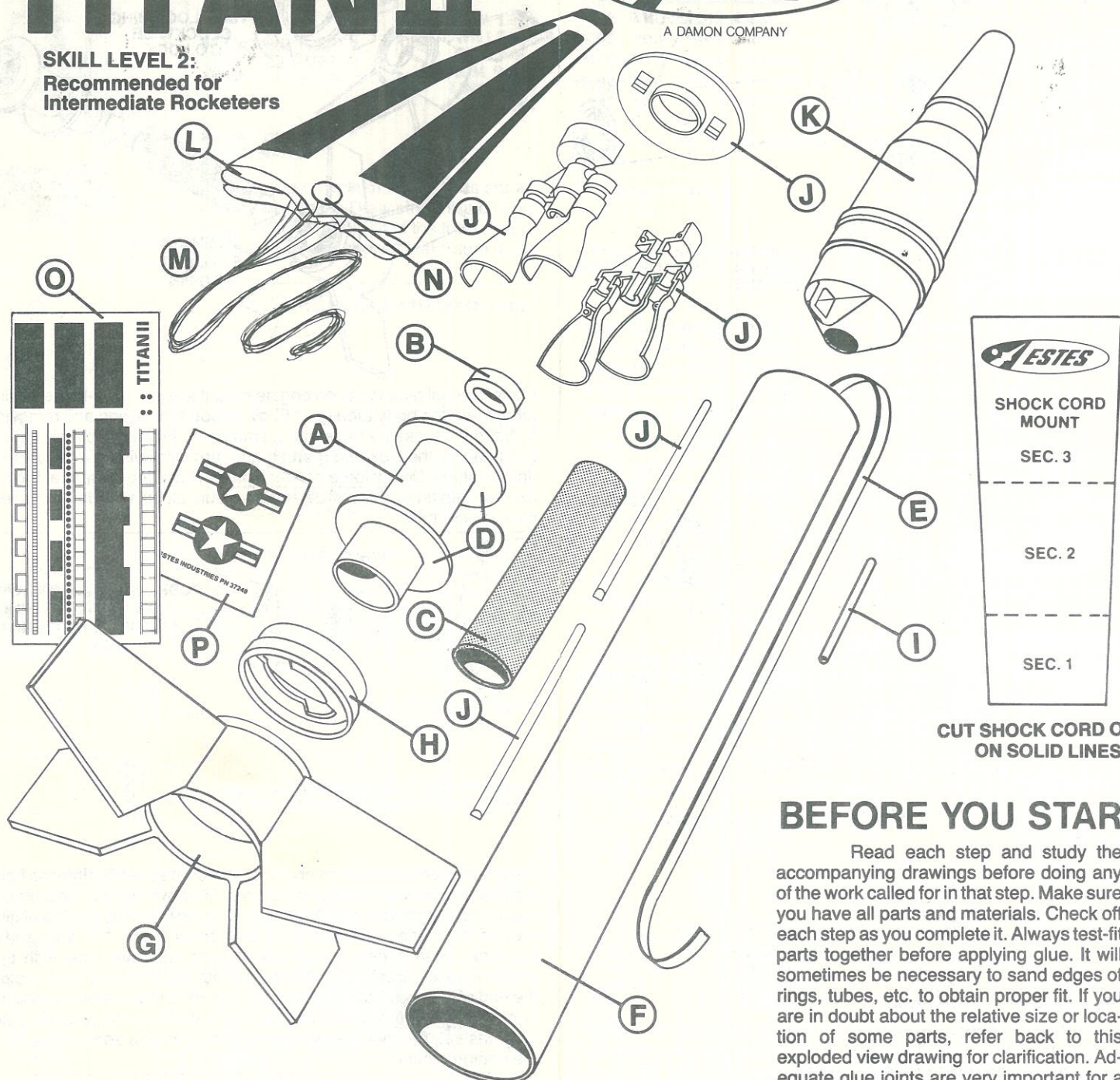

**CUT SHOCK CORD OUT
ON SOLID LINES**

BEFORE YOU START

Read each step and study the accompanying drawings before doing any of the work called for in that step. Make sure you have all parts and materials. Check off each step as you complete it. Always test-fit parts together before applying glue. It will sometimes be necessary to sand edges of rings, tubes, etc. to obtain proper fit. If you are in doubt about the relative size or location of some parts, refer back to this exploded view drawing for clarification. Adequate glue joints are very important for a flying model rocket. Follow the instructions carefully in this regard.

PARTS LIST KIT NO. 1918

A	1	Engine Mount Tube (type BT-20M) 2-1/4" Long .	30334
B	1	Engine Block (type AR-520)	30162
C	1	Engine Spacer Tube (type ET-2)	35003
D	2	Adapter Rings (type RA-2060)	30128
E	1	Shock Cord (type SC-1B)	85734
F	1	Body Tube (type BT-60 KC) 12-3/4" Long	30415
G	1	Fin-Unit (type 1918)	33304
H	1	Lock Ring (type 1918)	33305
I	1	Launch Lug (type LL-2A)	38175
J	1	Plastic Parts Set (type 1918)	33301
K	1	Nose Cone (type PNC-60T)	71018
L	1	Parachute (type PK-12)	85564
M	1	Shroud Line (type SLT-72)	38237
N	1	Tape Discs (type TD-3F)	38406
O	1	Decal (type KD-1918)	37233
P	1	Decal (type Lg Stars & Bars)	37249

TOOLS AND MATERIALS

In addition to the parts included in this kit you will need: Scissors, pencil, ruler, fine or extra-fine grit sandpaper, sanding sealer, a medium-size modeling paint brush, modeling knife with sharp blade, gloss white and silver enamel spray paint, flat black and medium gray enamel bottle paints, household white glue or resin glue (Elmer's, Titebond, or similar), tube-type plastic cement, and a bottle of contact cement. Other types of glue or cement are not recommended.

RECOMMENDED ENGINES: B4-4 (First Flight), B6-4, C6-3, and C6-5.

ASSEMBLY INSTRUCTIONS

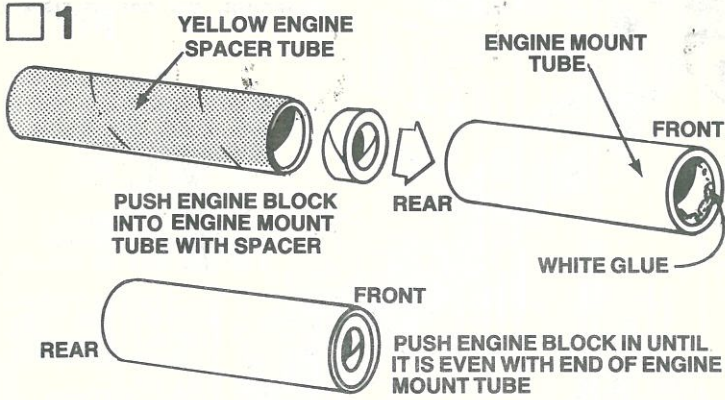

Apply glue around the inside of one end of the engine mount tube (part A) about $\frac{3}{16}$ " from the end of the tube. Immediately slide the engine block (part B) into the opposite end of the tube and push engine block up even with end of engine mount tube with the yellow engine spacer tube (part C). Immediately remove spacer tube and wipe away any excess glue from front of tube.

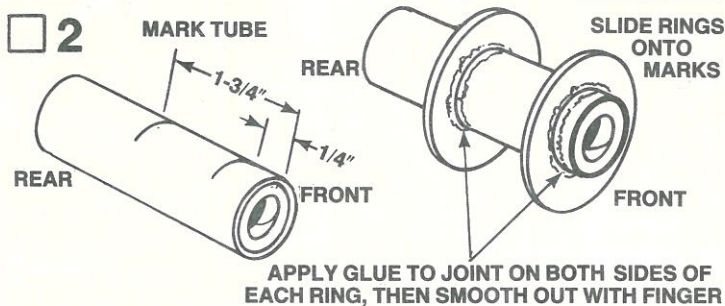

Mark the engine mount tube at $\frac{1}{4}$ " and $1\text{-}\frac{3}{4}$ " from the front (end with engine block). Carefully remove the two adapter rings from the die-cut card (part D). Use a sharp knife to free the rings from the card. Slide rings onto the tube so one is at each mark. Apply a line of glue around both sides of rings where it touches the tube. Smooth out glue with finger. Set the assembly aside to dry.

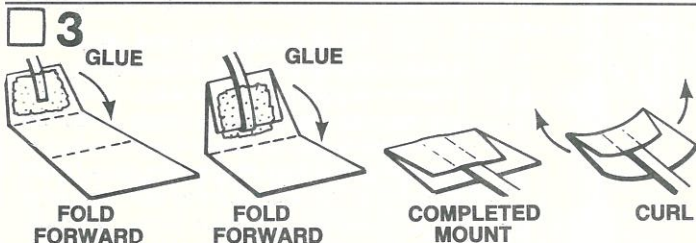

Cut out the shock cord mount from the front of the instruction sheet. Fold it on the dotted lines. Spread glue on the first section (1) and lay the end of the shock cord (part E) into the glue. Fold over and apply glue to the back of the first section and the exposed part of section 2. Lay the shock cord as shown and fold over again. Clamp the unit together with your fingers until the glue sets.

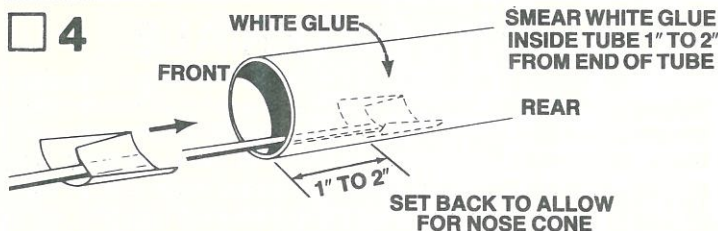

Use a finger or stick to apply glue to the inside of the front of the body tube (part F) 1" to 2" from the front of the tube. Press the shock cord mount firmly into position in glue far enough from the front edge of the tube to allow clearance for the nose cone to fit into place. To insure a good bond use a stick or your finger to smear a film of glue over the mount and surrounding area in the body tube.

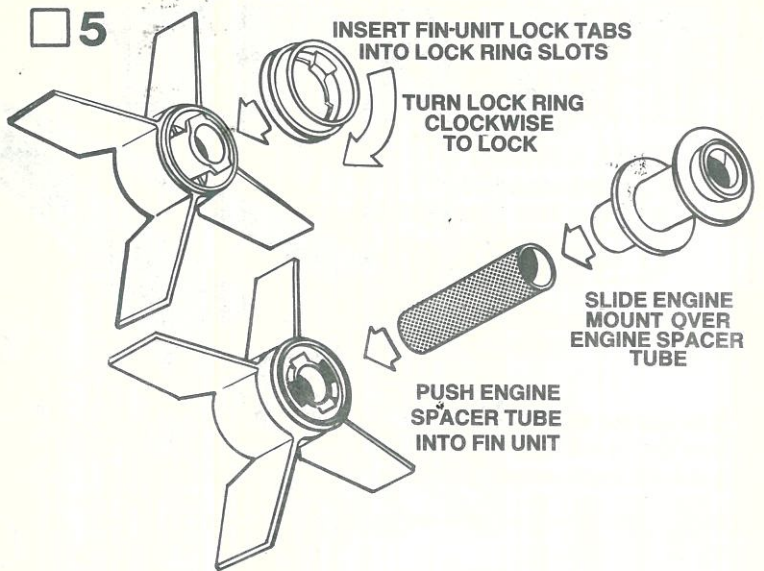

Make sure all glue joints on engine mount are dry. Test-fit the engine mount into the body tube (part F) by smoothly inserting and removing it. Sand if necessary to assure a smooth fit. Insert the plastic fin-unit (part G) into the lock ring (part H) and turn clockwise $\frac{1}{4}$ turn or until fin-unit stops. Do not force or over tighten. Push engine spacer tube all the way into fin-unit and slide engine mount all the way down onto engine spacer tube.

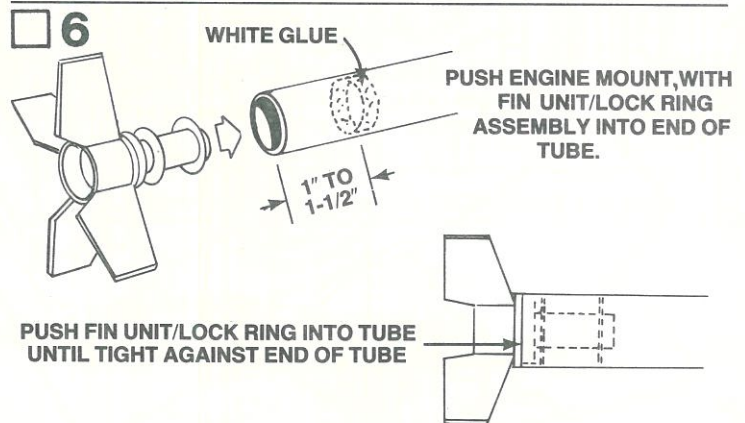

Test-fit the complete fin unit and engine mount assembly into the body tube to see how the assembly works. Remove fin-unit and engine mount from body tube and re-assemble on fin-unit. Apply a ring of glue around the inside rear of the body tube about 1" to $1\text{-}\frac{1}{2}$ " from end of the tube. Slide engine mount and fin-unit into body tube with one smooth motion, push fin-unit/lock ring into the tube and tight against the end of the body tube. Don't stop or pause until this point is reached or glue may "grab" with the engine mount in the wrong position. After glue has set, remove fin-unit, lock ring, and engine spacer tube from the engine mount.

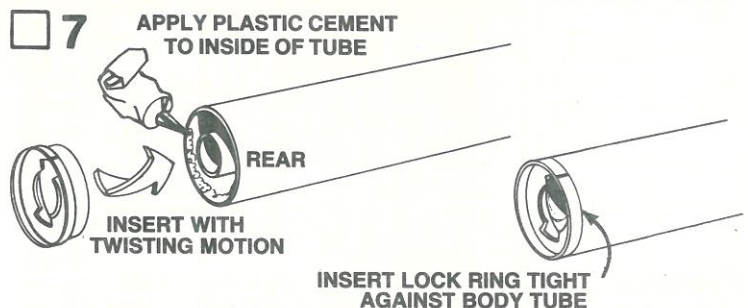

Remove the fin-unit from the lock ring by turning counter-clockwise. Apply a line of tube-type plastic cement around the inside rear of the body tube. Slide the lock ring into the end of the body tube and twist it as it is pushed into place. Be sure it is inserted all the way. Stand rocket body vertically on the lock ring and allow cement to dry. Do not put fin-unit into lock ring until cement is completely dry.

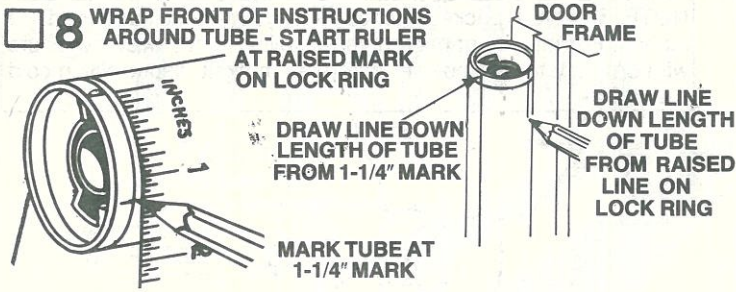

Mark body tube 1-1/4" from raised line on side of lock ring as shown with ruler printed on front of instruction sheet. Draw straight lines from the raised line and the 1-1/4" mark down the length of the tube. A door frame inside edge can be used as a guide as shown. Make sure these lines are straight along tube.

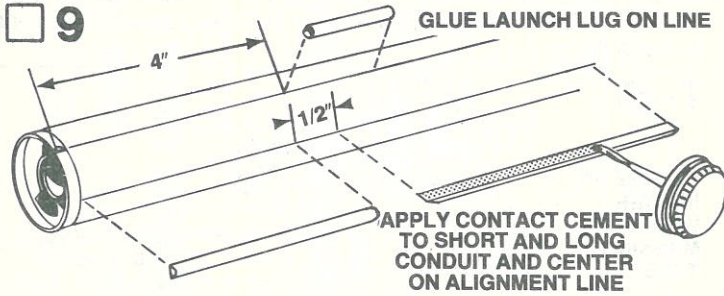

Glue the launch lug (part I) to rocket body tube on line drawn up from raised line on lock ring. The rear of the launch lug should be 4" from the rear of the lock ring. Align the launch lug straight with the body tube. Apply contact cement to the flat side of the plastic conduits from plastic parts (part J). Align them on their alignment line as shown. Wipe away any excess cement and set aside to dry.

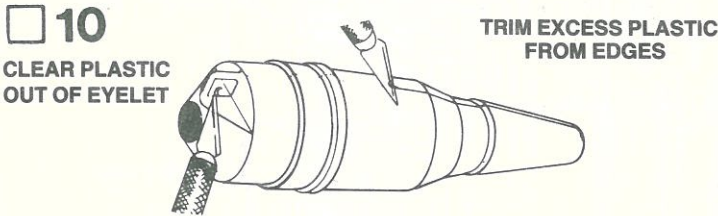

Trim or sand any excess plastic from around the sides of the nose cone (part K). Use a sharp knife to remove any excess plastic from the inside of the molded eyelet at the rear of the nose cone.

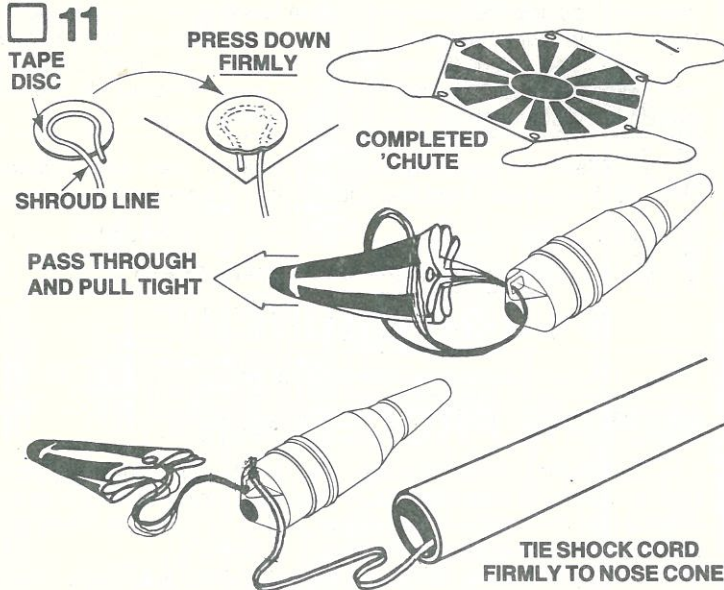

Cut out the parachute (part L) on its edge lines. Cut three equal lengths of shroud line (part M). Attach line ends to the top of the parachute with tape discs (part N) as shown. Form a small loop in the

end of a shroud line. Holding loop, gently loop inside tape disc on the sticky side. Then carefully press tape disc onto its proper place on the top of the parachute. Firmly press the tape disc into place until both tape disc and parachute material are molded around the shroud line loop. Repeat for other shroud line ends and tape discs. Pass the shroud line loops through the loop on the nose cone. Pass the parachute through the loop ends and pull the lines tight against the nose cone. Tie the free end of the shock cord firmly to the nose cone loop. A square knot or strong double knot should be used. Pack parachute and shock cord into rocket body and slip nose cone into place.

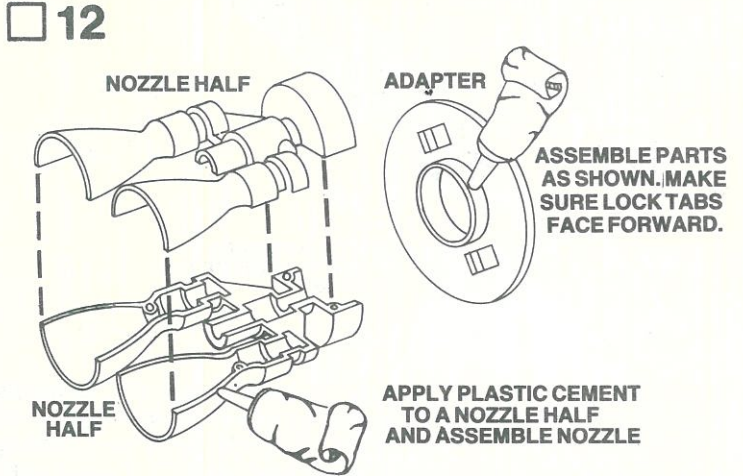

Locate plastic display nozzle parts from the plastic parts set. Carefully trim away the small projections where the parts were connected to the molding sprue. Assemble the parts using tube-type plastic cement. Set aside to dry.

PAINTING AND DETAILING

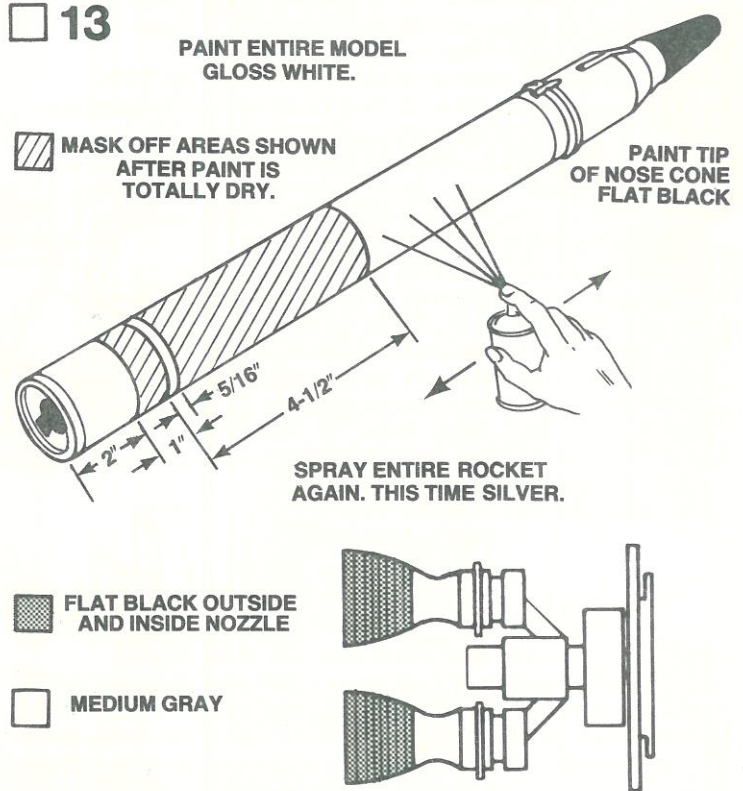

After glue and cement are dry on model, paint entire model gloss white. After paint is thoroughly dry, mask off areas shown and paint model silver. You may, if you wish, mask off fins so fins remain clear and paint fin-unit silver also. We recommend spray enamel for best results. Do not paint the model with lacquer paint. Follow instructions on spray can for best results. Paint display nozzles as shown.

DECAL PLACEMENT

□ 14

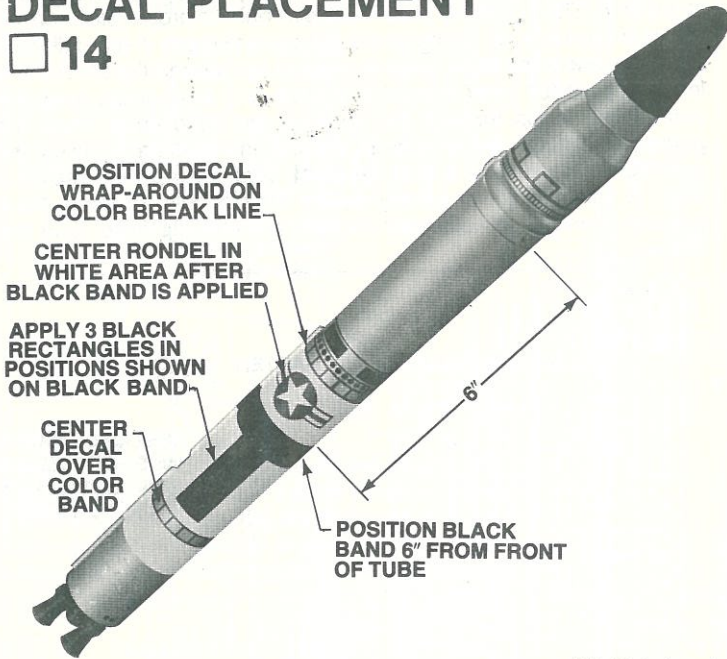

Apply decals (part O and P) in the positions shown. (A) Cut decals apart. (B) Dip one decal at a time in lukewarm water for 10-20 seconds. Hold until it starts to uncurl. (C) Slip decal from backing paper onto model. (D) Move decal into exact position. If decal sticks before you have it in position, apply water to the decal so it can be moved. (E) Carefully blot away excess water with soft cloth. Smooth out all wrinkles and air bubbles before decal dries. We recommend that the completed model be sprayed with a clear flat or clear gloss to protect the model's finish.

LAUNCHING COMPONENTS

- To launch your rocket you will need the following items:
- An Estes model rocket launching system
 - Flame resistant recovery wadding (Estes Cat. No. 2274)
 - Estes A8-3, B4-4, B6-4, C6-3, or C6-5 model rocket engines.
- Use a B4-4 engine for your first flight.

Be sure to follow the HIAA-NAR* Model Rocket Safety Code when carrying out your model rocket activities.
 *HIAA—Hobby Industry of America
 *NAR—National Association of Rocketry

COUNTDOWN CHECKLIST

T-13

Remove nose cone. Pack 4 squares of loosely crumpled recovery wadding into the body tube.

T-12

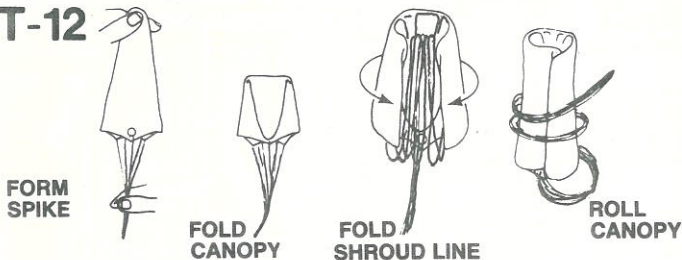

Hold the parachute at its center and pass the other hand down it to form a "spike" shape. Fold this spike in half. Fold shroud lines back along parachute and then back down to lower edge of parachute to reduce length of shroud line "left over". Roll parachute into tube shape to fit easily into body. Any remaining shroud line should be loosely wrapped around parachute. Pack 'chute into the body tube on top of the wadding. Pack the shroud lines and shock cord in on top of the parachute and slip the nose cone into place.

NOTE: DO NOT pack parachute until you are actually ready to launch. For maximum parachute reliability, lightly dust the 'chute with ordinary talcum powder before each flight, especially in cold weather.

T-11

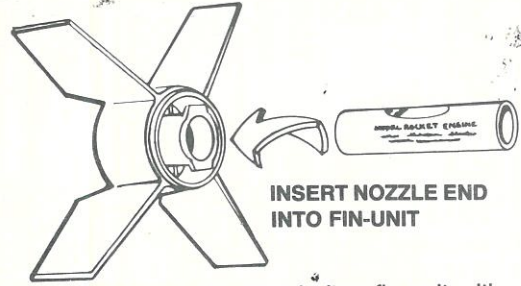

Select an engine and push it securely into fin-unit with a twisting motion. The engines recommended for use with this rocket are the A8-3, B4-4, B6-4, C6-3, and C6-5 made by Estes. Use a B4-4 engine for first flight.

T-10

SECURE IGNITER WITH MASKING TAPE

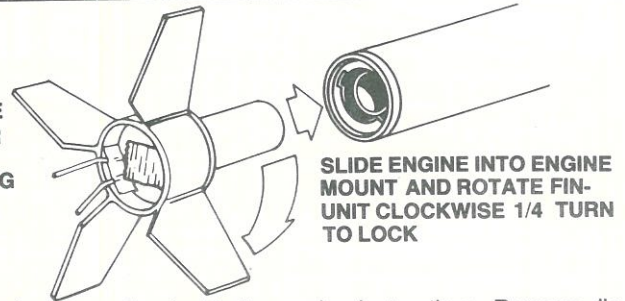

Install an igniter as directed in the engine instructions. Remove display nozzle from rocket, slide engine into engine mount. Insert fin-unit lock tabs into lock ring slots and turn clockwise 1/4 turn or until fin-unit stops. Do not force or over tighten.

T-9 Disarm the launch panel—REMOVE SAFETY KEY!

T-8

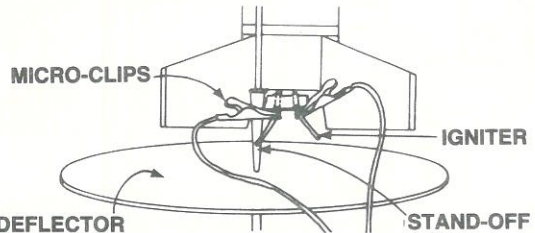

Slide the launch rod through rocket launch lug. Make sure the rocket slides freely on the launch rod. The rocket must be supported by a "stand-off" to keep the igniter wires from touching the metal blast deflector. If your launch system does not have a stand-off, wrap a piece of masking tape around the launch rod to support the rocket. Clean the micro-clips and attach them to the igniter wires. Arrange the clips so they do not touch each other or the metal blast deflector.

T-7 Clear the launch area. Alert recovery crew and trackers. Check for low flying aircraft and unauthorized persons in the recovery area.

T-6 Arm the launch panel—INSERT SAFETY KEY!

5-4-3-2-1-LAUNCH!!

Repeat Countdown Checklist for each flight.

MISFIRE PROCEDURE

Disarm the launch panel. Wait one minute before approaching the rocket on the launch pad. Remove the rocket, clean the igniter residue from the nozzle of the engine, and carefully install a new igniter. Repeat the Countdown Checklist.

Failure of the rocket engine to function properly is nearly always caused by a failure to install the igniter correctly. This failure permits the igniter to heat and burn into two pieces without igniting the engine.