

MARTA BOMBER

**SKILL LEVEL 3 - Recommended for
Craftsman Rocketeers**



A DAMON COMPANY

ESTES INDUSTRIES
PENROSE, CO 81240 USA

**RECOMMENDED
ENGINES:**
A8-3, B4-4, B6-4,
C5-3, C6-3
(First Flight A8-3)

BEFORE YOU START

Read each step and study the accompanying drawings before doing any of the work called for in that step. Make sure you have all parts and materials. Check off each step as you complete it. Always test-fit parts together before applying glue. It will sometimes be necessary to sand edges of rings, tubes, etc. to obtain proper fit. If you are in doubt about the relative size or location of some parts, refer back to this exploded view drawing for clarification. Adequate glue joints are very important for a flying model rocket. Follow the instructions carefully in this respect.

PARTS LIST KIT NO. 1928

A	2	Body Tubes (type BT-5P) 5" Long	30306
B	2	Body Tubes (type BT-20AE) 1-1/2" Long	30318
C	3	Centering Rings (type AR-520)	30162
D	1	Engine Mount Tube (type BT-20J) 2-3/4" Long	30326
E	1	Balsa Die Cut Sheet (type BF-1928)	32628
F	2	Rings (type JT-80C)	30274
G	1	Engine Hook (type EH-2)	35025
H	2	Centering Rings (type AR-2050)	30164
I	1	Body Tube (type BT-50 FE) 6-1/2" Long	30359
J	1	Alignment Guide (on back of kit panel)	83704
K	1	Launch Lug (type LL-2B)	38178
L	1	Wood Dowel 12" Long	32058
M	1	Nose Cone (type PNC-50)	71000
N	1	Shock Cord (type SC-1)	85730
O	1	Parachute (type PK-12A)	85564
P	1	Shroud Line (type SLT-72)	38237
Q	1	Tape Discs (type TD-3F)	38406
R	1	Decal (type KD-1928)	37243

TOOLS AND MATERIALS

In addition to the parts included in this kit you will need: Scissors, tweezers, pencil, ruler, fine or extra-fine grit sandpaper, sanding sealer, a medium-size modeling paint brush, masking tape, modeling knife with sharp blade, gloss white enamel spray paint, and household white glue or resin glue (Elmer's, Titebond, or similar). Other types of glue are not recommended.

Be sure to follow the HIAA-NAR* Model Rocket Safety Code when carrying out your model rocket activities.

*HIAA—Hobby Industry of America

*NAR—National Association of Rocketry

INCHES
1
2
3
4
5
6
7
8
9
10

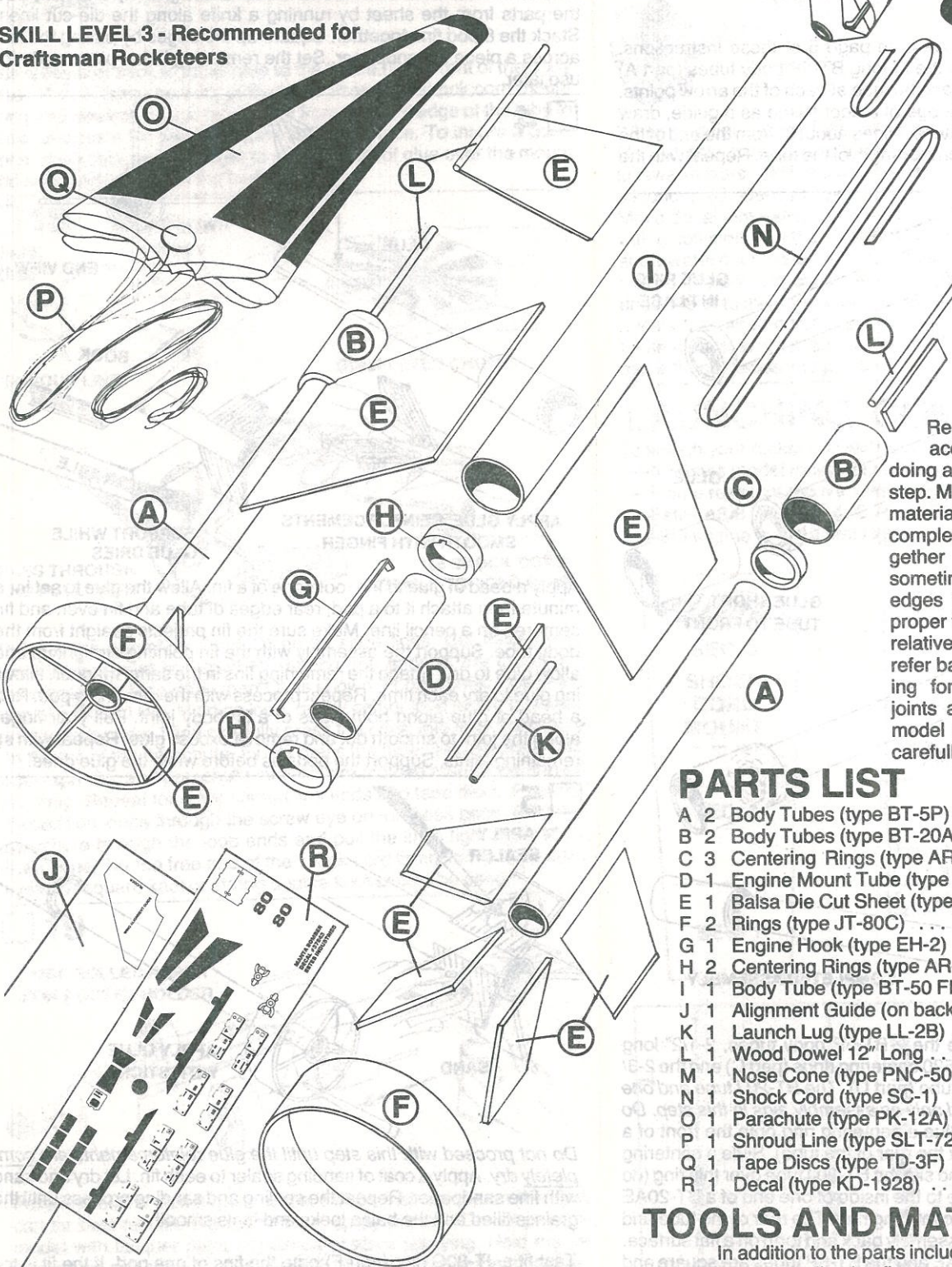

SECTION 1 - POD ASSEMBLIES

1

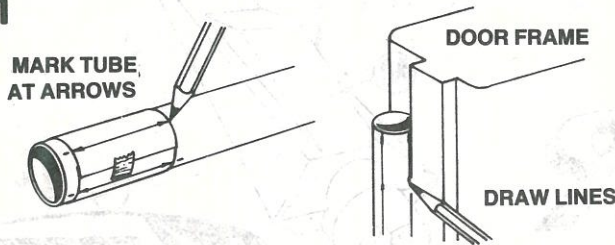

Cut out the BT-5 marking guide from page 5 of these instructions. Wrap the guide around one of the 5" long BT-5P body tubes (part A) and tape the ends together. Mark the tube at each of the arrow points. Remove the guide. Using the edge of a door frame as a guide, draw lines connecting the marks. Extend 3 lines about 2" from the end of the tube. Draw the fourth line the entire length of the tube. Repeat with the other BT-5P tube.

2

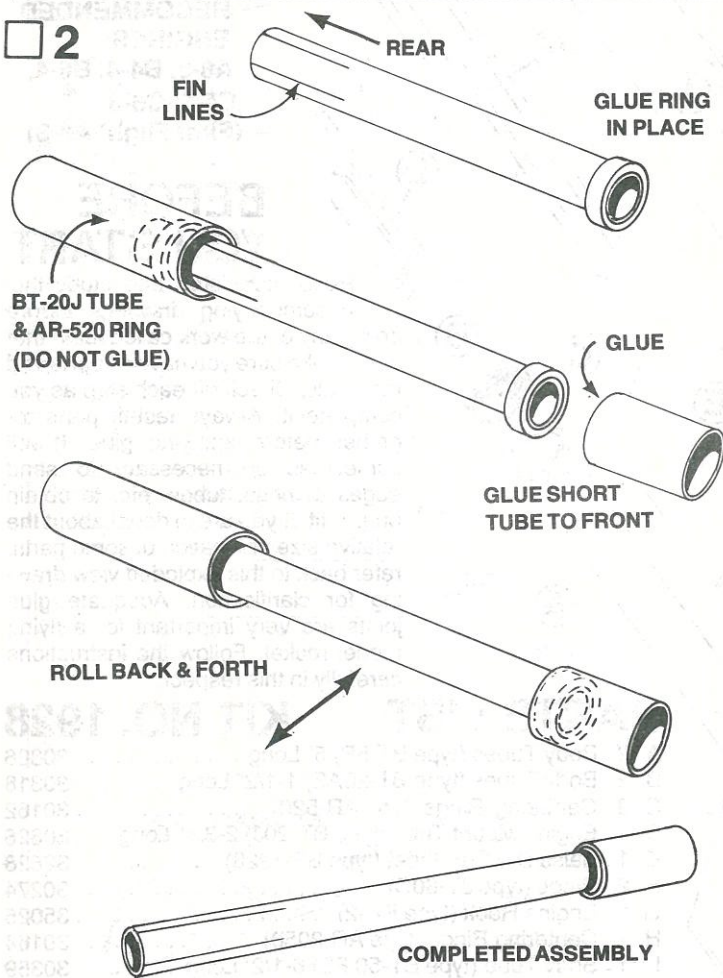

Parts required in this step are the 2 BT-5P body tubes, 2-1/2" long BT-20AE tubes (part B), 3 AR-520 centering rings (part C) and the 2-3/4" long BT-20J engine mount tube (part D). *The BT-20J tube and one of the centering rings are used only as assembly aids in this step. Do not apply any glue to them.* Glue a centering ring onto the front of a BT-5P tube (the fin lines are at the rear of the tube). Slide a centering ring onto the rear of the tube and slip the BT-20J tube over this ring (do not glue). Apply a bead of glue to the inside of one end of a BT-20AE tube and slide it onto the front centering ring. The rear of the tube and ring should be even. Roll the assembly back and forth on a flat surface. This will insure that the BT-20AE and the BT-5P tubes are square and parallel. Remove the BT-20J tube and ring from the rear of the assembly. Make a second assembly in the same manner. After completion, lay the BT-20J tube aside. It will be used later. The AR-520 ring may be discarded.

3

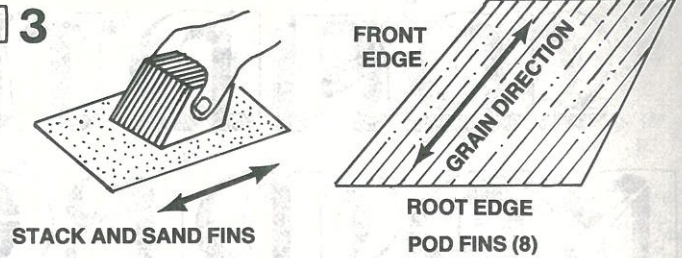

Fine sand both sides of the balsa die-cut sheet (part E). Carefully free the parts from the sheet by running a knife along the die-cut lines. Stack the 8 pod fins together. Square up the edges by pulling the fins across a piece of sandpaper. Set the remaining balsa parts aside for use later.

4

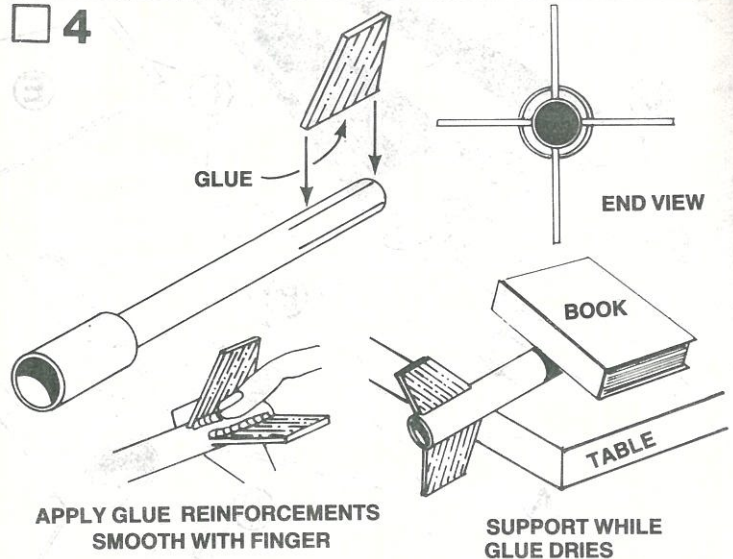

Apply a bead of glue to the root edge of a fin. Allow the glue to set for a minute then attach it to a pod, rear edges of tube and fin even and fin centered on a pencil line. Make sure the fin projects straight from the body tube. Support the assembly with the fin pointing straight up and allow glue to dry. Attach the remaining fins in the same manner, allowing glue to dry each time. Repeat process with the remaining pod. Run a bead of glue along both sides of a fin-body joint. Pull your finger along the joint to smooth out and remove excess glue. Repeat with all remaining joints. Support the pods as before while the glue dries.

5

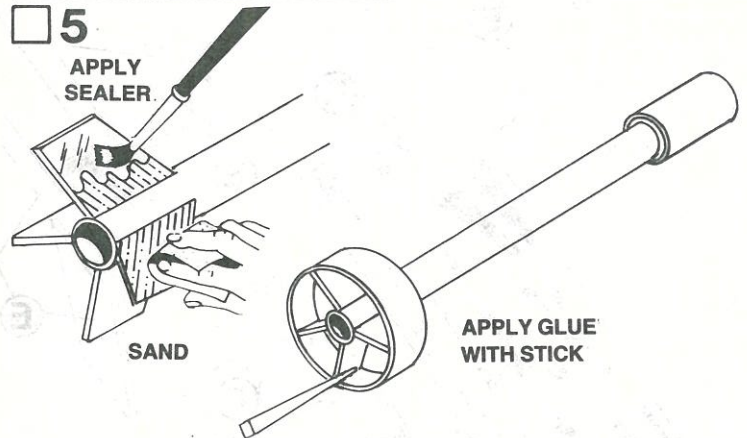

Do not proceed with this step until the glue reinforcements are completely dry. Apply a coat of sanding sealer to each fin. Let dry and sand with fine sandpaper. Repeat the sealing and sanding process until the grain is filled and the balsa looks and feels smooth.

Test fit a JT-80C ring (part F) onto the fins of one pod. If the fit is too tight, it will cause the ring to distort and be "out of round". If this happens, sand the outside edges of the 4 fins until the ring fits correctly. Position the ring on the fins and use a small stick to apply glue to the fin-ring joints. Repeat the process with the other pod.

SECTION 2 - MAIN BODY ASSEMBLY

6

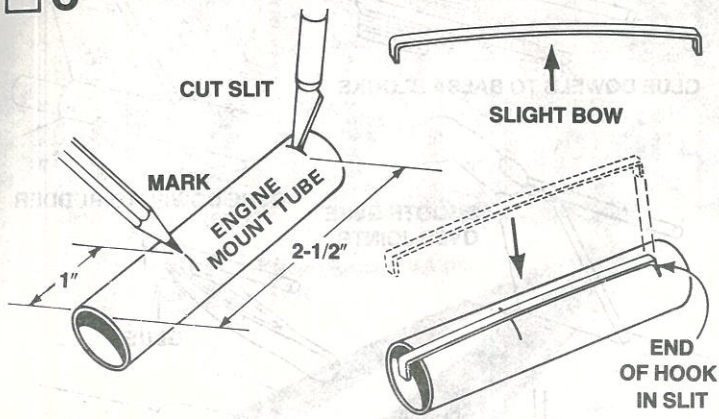

Mark the engine mount tube (part D) at 1" and 2-1/2" from one end. Cut a 1/8" long slit at the 2-1/2" mark. Gently bend the engine hook (part G) so that it bows upward very slightly in the middle. (Study the drawing.—Don't bend the wrong way.) Insert one end of the engine hook into the slit in the tube.

7

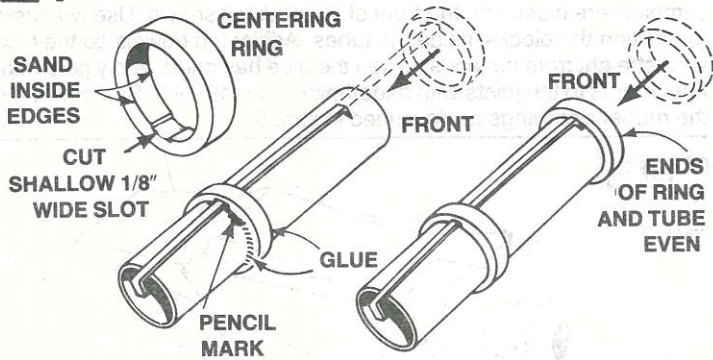

Sand the inside edges of the two AR-2050 centering rings (part H) to remove burrs. The rings should slide easily onto the engine mount tube. Cut a very shallow 1/8" wide slot inside one centering ring so it will fit over the engine hook. Slip the ring onto the front end of the engine mount tube and slide it down to the 1" mark. Make sure the engine hook runs straight down the tube, then apply glue to both sides of this ring. Apply glue around the front end of the engine mount tube and slide the remaining centering ring into place (front of ring even with the end of the tube).

8

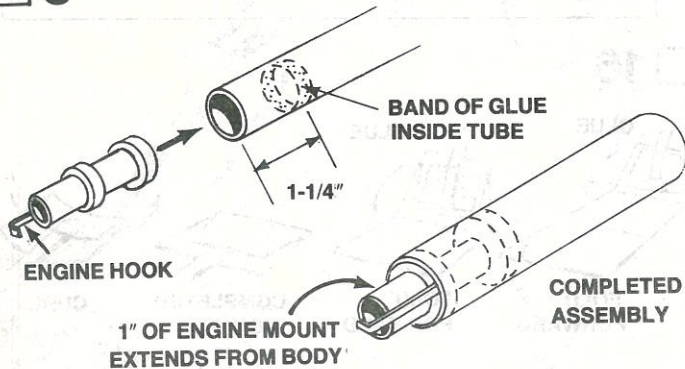

Use a small stick to apply a generous band of glue about 1-1/4" inside one end of the BT-50FE body tube (part I). Making sure the engine hook extends to the rear, slide the engine mount into the body tube. Without pausing, slide the engine mount forward until the rear ring is even with the rear of the body tube.

9

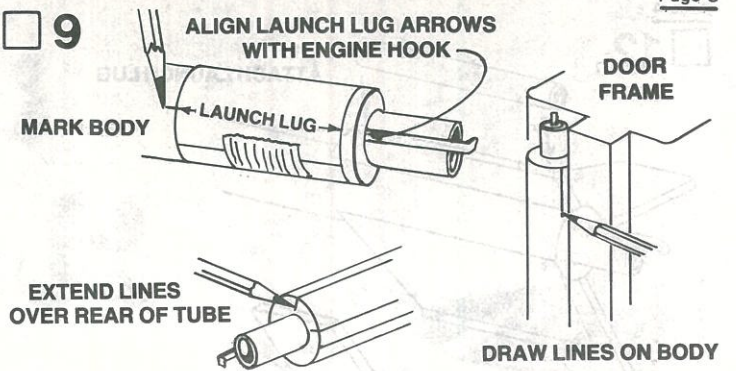

Cut the BT-50 marking guide from page 5 of the instructions. Wrap the guide around the rear of the body tube and tape the ends together. Rotate the guide so the launch lug arrow is lined up with the engine hook. Mark the location of the launch lug, rudder and wings. Remove the guide and draw lines from the rear of the tube forward about 3". Extend the lines over the rear of the tube so they will show when the parts are attached.

10

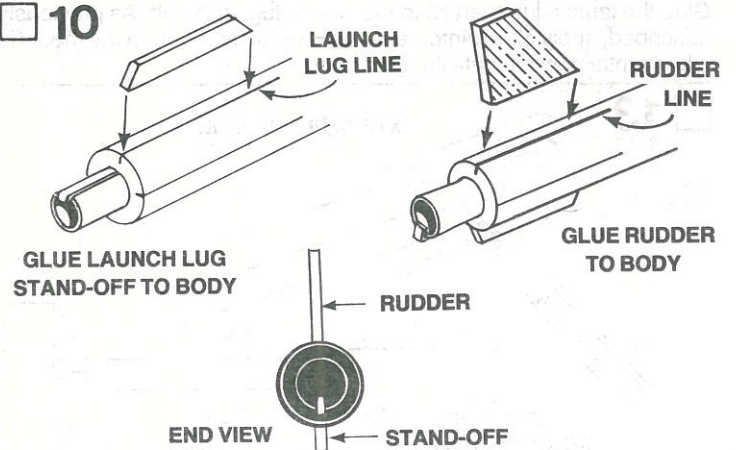

Sand the edges square on the remaining balsa parts. Lay the 2 small rectangles aside for use later. Glue the launch lug stand-off to the body as shown. Remember, the launch lug line is the one that is lined up with the engine hook. Next, glue the rudder to the opposite side of the body. Support the body as previously described and allow the glue to dry thoroughly.

11

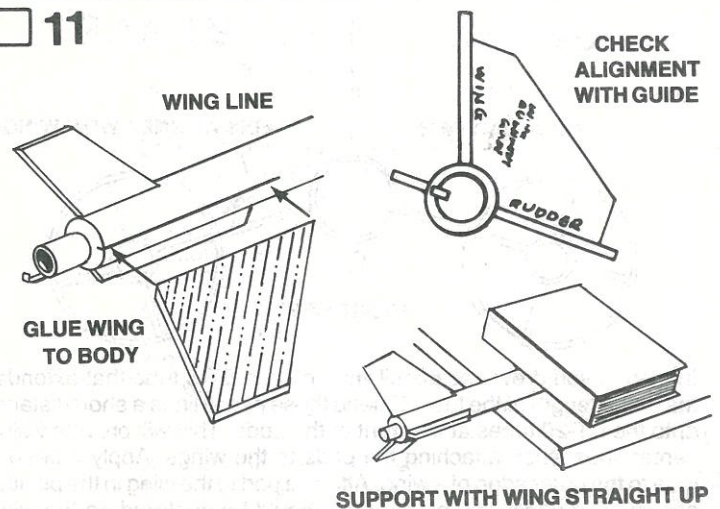

Cut the wing alignment guide from the back of the kit panel (part J). Apply glue to the root edge of a wing and attach it to the body. Use the guide to check wing-rudder alignment. Support the model with the wing pointing straight up. Re-check the alignment after a few minutes and make corrections if necessary. Leave the model undisturbed until the glue is completely dry. Attach the remaining wing in the same manner.

12

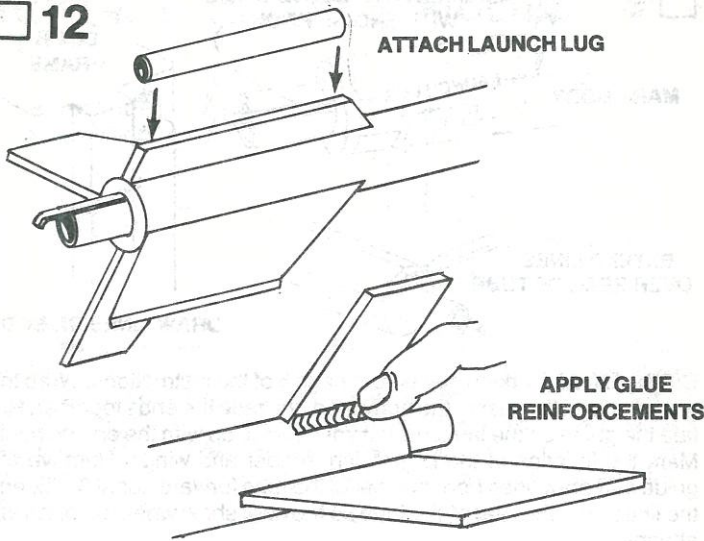

Glue the launch lug (part K) to the launch lug stand-off. As previously described, apply glue reinforcements to all joints. Support the model in a horizontal position until the glue dries.

13

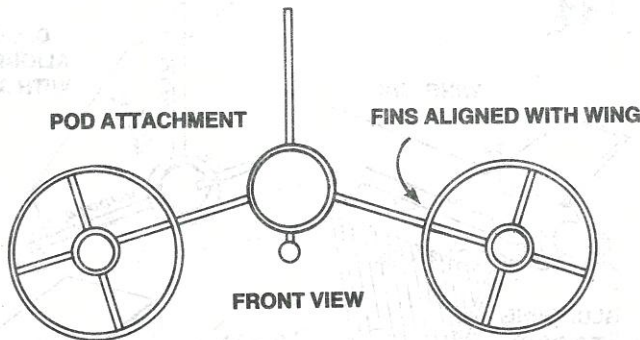
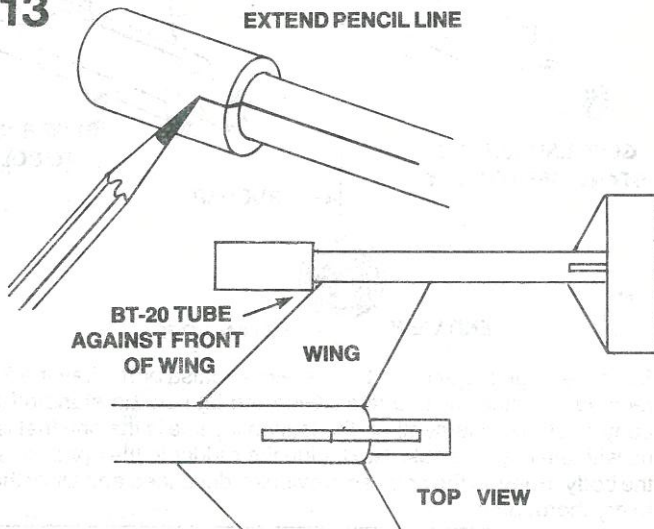

In step 1, you drew one pencil line on each BT-5 tube that extended the entire length of the tube. Extend those pencil lines a short distance onto the BT-20 tubes at the front of the pods. This will provide visible center lines when attaching the pods to the wings. Apply a bead of glue to the outer edge of a wing. Attach a pod to the wing in the position shown. The pencil line on the pod should be centered on the wing. Look at the assembly from the side and make sure the pod is straight with the body. Hold the pod in place until the glue has almost dried. Support the assembly on a table edge (previously described) with the wing and pod straight up. Re-check alignment and allow the glue to dry thoroughly. The second pod is attached to the other wing in the same manner. After the glue has completely dried, apply glue reinforcements to the pod-wing joints. Support in a horizontal position until the glue dries.

14

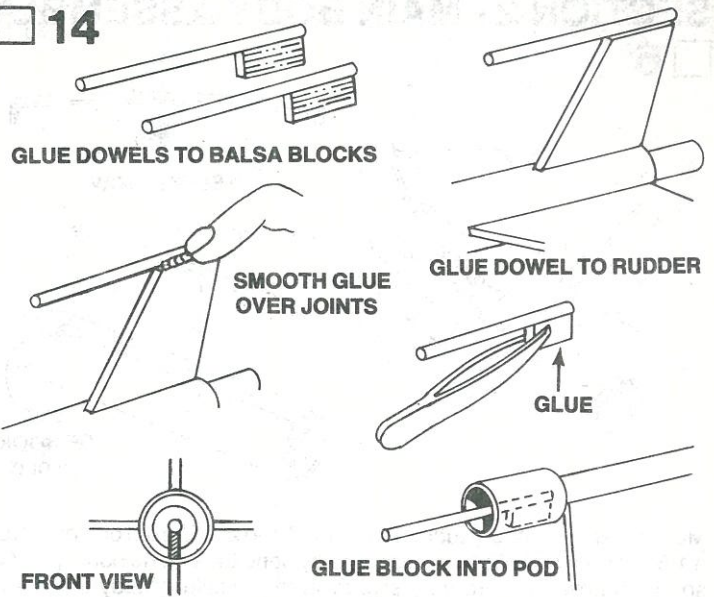

Cut the wood dowel (part L) into four 3" lengths (only 3 pieces will be used). Locate the 2 balsa blocks (from fin sheet). Glue 2 dowels to them as shown. Glue the third dowel to the top of the rudder. Smooth a film of glue over the joints with your finger. The 2 dowel-balsa block assemblies are glued into the front of the pods as shown. Use tweezers to position the blocks inside the tubes. Adjust the dowels so they extend straight from the pods. When the glue has dried, apply glue reinforcements to the joints with a toothpick or small stick. Seal and sand the rudder and wings as described in step 5.

15

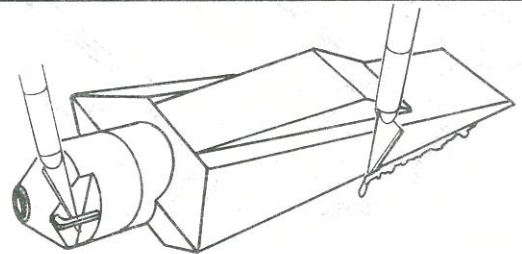

Trim or sand any excess plastic from around the sides of the nose cone (part M). Use a sharp knife to remove any excess plastic from the inside of the molded eyelet at the rear of the nose cone. Wash the nose cone with lukewarm soapy water, rinse well, and dry.

NOTE: Nose cone should separate easily from rocket body tube, but should not be extremely loose. If fit is too tight, sand inside of body tube and shoulder of nose cone with fine sandpaper. If fit is too loose, add a wrapping of transparent tape to the shoulder of the nose cone.

16

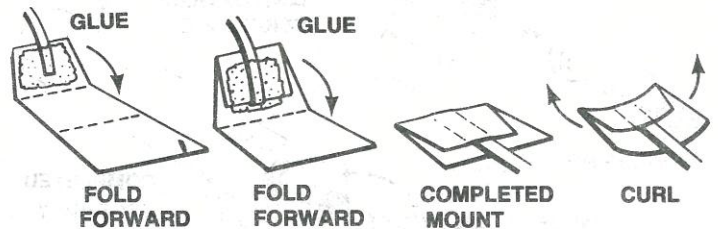

Cut out the shock cord mount from page 5 of the instructions. Fold on dotted lines, then unfold and apply glue to Section 1. Lay the end of the shock cord (part N) into the glue. Fold over and apply glue to the back of Section 1 and the exposed portion of Section 2. Fold again to complete mount. Curl the edges of the mount up so it will match the contour of the body tube and hold with your fingers until the glue sets.

17

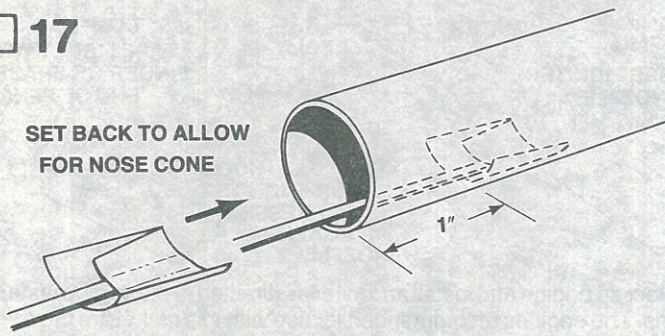

Use a finger or stick to apply glue to the inside of the front of the body tube, 1" to 2" from the front of the tube. Press the shock cord mount firmly into position in glue far enough from the front edge of the tube to allow clearance for the nose cone to fit into place. To insure a good bond use a stick or your finger to smear a film of glue over the mount and surrounding area in the body tube.

18

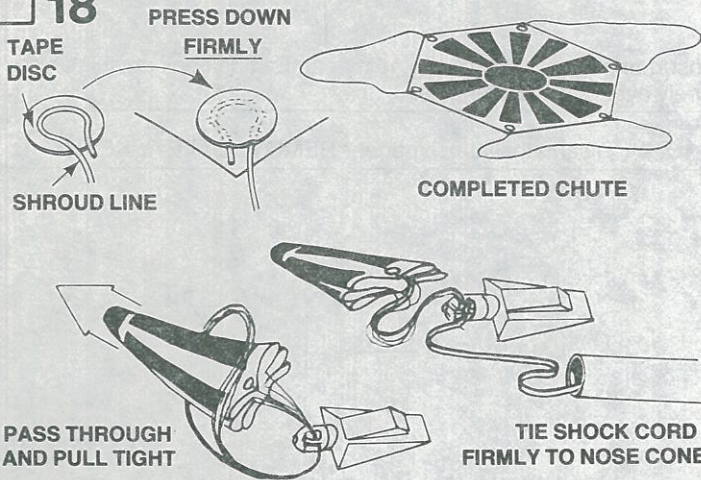

Cut out the parachute (part O) on its edge lines. Cut three equal lengths of shroud line (part P). Attach line ends to the top of the parachute with tape discs (part Q) as shown. Form a small loop in the end of a shroud line. Holding loop, gently center loop inside tape disc on the sticky side. Then carefully press tape disc into its proper place on the top of the parachute. Firmly press the tape disc into place until both tape disc and parachute material are molded around the shroud line loop. Repeat for other shroud line ends and tape discs. Pass the shroud line loops through the screw eye on the nose cone. Pass the parachute through the loop ends and pull the lines tight against the nose cone. Tie the free end of the shock cord firmly to the nose cone eyelet. A square knot or strong double knot should be used.

19

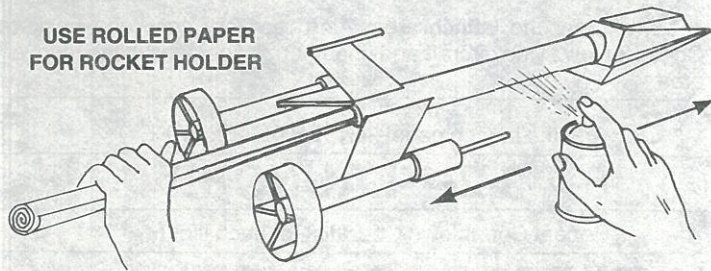

Paint the entire model gloss white. Follow instructions on the spray can for best results. We recommend spray enamel. Do not paint the model with lacquer paint. Shake can before spraying. Hold the can straight up and spray in long, smooth "strokes". Spray the model with several light, dry mist coats of paint to avoid "runs". Shake can periodically. To obtain a gloss, final coat should be applied slightly heavier. Let this coat dry overnight. Be sure paint is completely dry before applying decals.

20

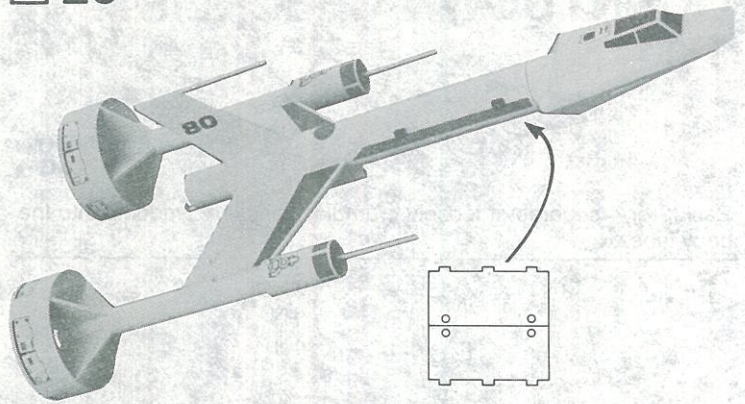

When all paint is dry, apply the decals (part R) in the positions shown. (A) Cut only one decal at a time from sheet. (B) Submerge decal in lukewarm water until decal slides on backing paper (usually 15 to 30 seconds). (C) Gently slide decal from backing paper onto model. (D) Move decal into exact position and carefully blot away excess water with a soft cloth. (E) If the decal "sticks" before you have it in position, apply water over the decal with a brush. This will permit the decal to be moved. (F) Smooth out all wrinkles and air bubbles before the decal dries. Refer to the photograph for decal positions. There are two large decals that wrap completely around the tail rings. Before applying these decals, wet the surface of the rings. This will make it easier to move these decals into position.

LAUNCHING COMPONENTS

To launch your rocket you will need the following items:

- An Estes model rocket launching system
- Flame resistant recovery wadding (Estes Cat. No. 2274)
- Estes A8-3 B4-4, B6-4, C5-3, or C6-3 model rocket engines. Use an A8-3 engine for your first flight.

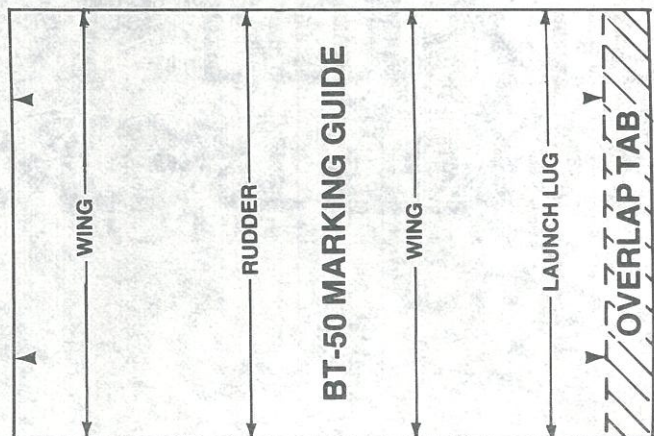
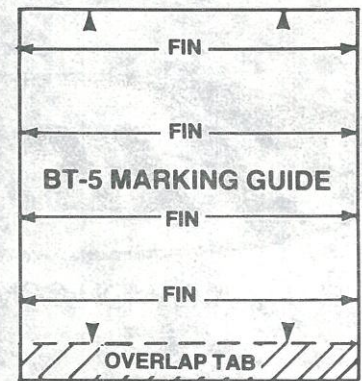
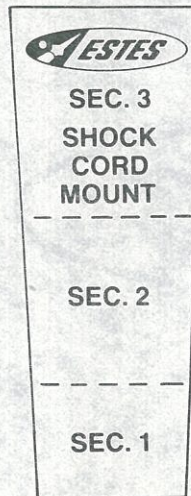

COUNTDOWN CHECKLIST

T-13

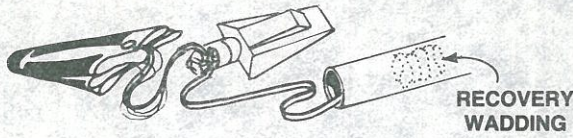

Pack 3 or 4 squares of loosely crumpled recovery wadding into the body tube.

T-12

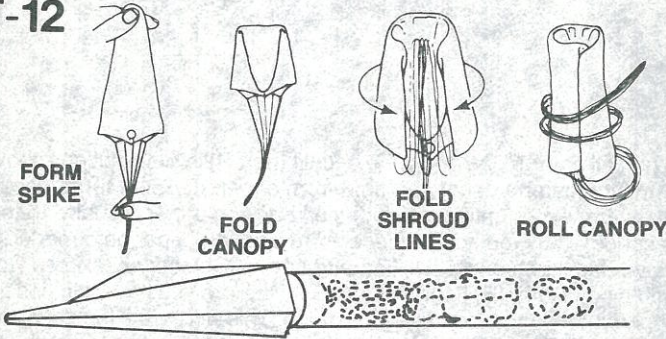

Hold the parachute at its center and pass the other hand down it to form a "spike" shape. Fold this spike in half. Fold shroud lines back along parachute and then back down to lower edge of parachute to reduce length of shroud line "left over". Roll parachute into tube shape to fit easily into body. Any remaining shroud line should be loosely wrapped around parachute. Pack 'chute into the body tube on top of the wadding. Pack the shroud lines and shock cord in on top of the parachute and slip the nose cone into place.

NOTE: DO NOT pack parachute until you are actually ready to launch. For maximum parachute reliability, lightly dust the 'chute with ordinary talcum powder before each flight, especially in cold weather.



A DAMON COMPANY

MANTA BOMBER

T-11

INSERT IGNITER IN NOZZLE

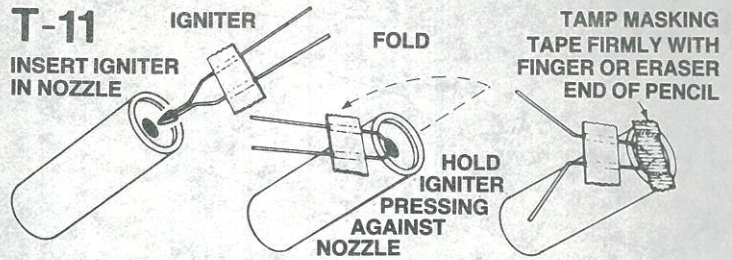

Select an engine and install an igniter as directed in the engine instructions. The engines recommended for use with this rocket are the A8-3, B4-4, B6-4, C5-3, and C6-3. Use an A8-3 for your first flight.

T-10

ENGINE HOOK MUST LATCH SECURELY

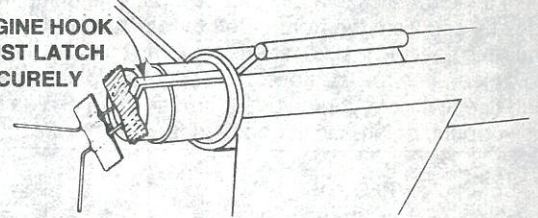

Insert engine into rocket engine mount. Engine hook must latch securely over end of the engine.

T-9

Disarm the launch panel—REMOVE SAFETY KEY!

T-8

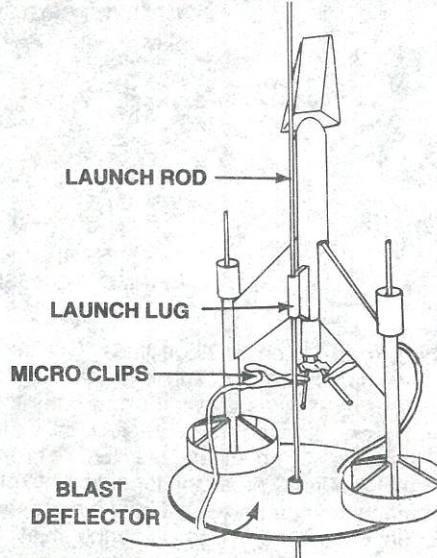

Slide the launch rod through rocket launch lug and place rocket on launch pad. Make sure the rocket slides freely on the launch rod. Clean the micro-clips and attach them to the igniter wires. Arrange the clips so they do not touch each other or the metal blast deflector. Attach clips as close to protective tape on igniter as possible.

T-7

Clear the launch area. Alert recovery crew and trackers. Check for low flying aircraft and unauthorized persons in the recovery area.

T-6

Arm the launch panel—INSERT SAFETY KEY!

5-4-3-2-1-LAUNCH!!

Repeat Countdown Checklist for each flight.

MISFIRE PROCEDURE

Disarm the launch panel. Wait one minute before approaching the rocket on the launch pad. Remove the rocket, clean the igniter residue from the nozzle of the engine, and carefully install a new igniter. Repeat the Countdown Checklist.

Failure of the rocket engine to function properly is nearly always caused by a failure to install the igniter correctly. This failure permits the igniter to heat and burn into two pieces without igniting the engine.