



A DAMON COMPANY

ESTES INDUSTRIES
1295 H STREET
PENROSE, CO 81240 USA

STEALTH™

FLYING MODEL ROCKET KIT #1929

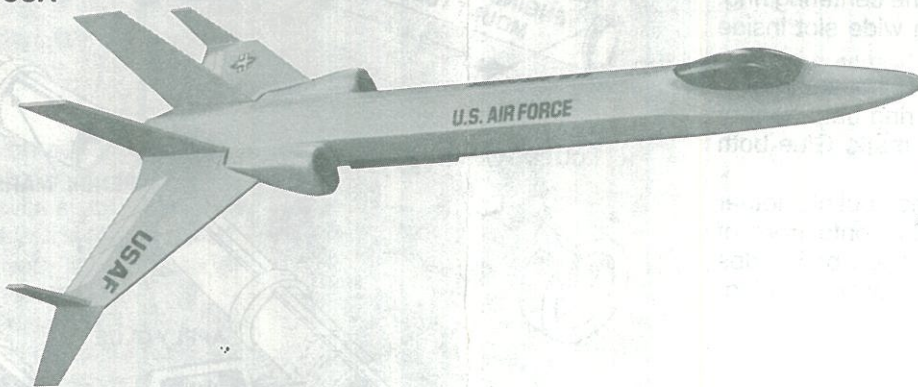

SHOCK
CORD
MOUNT

SECTION 3

CUT OUT
SHOCK CORD
MOUNT ON
SOLID LINES

SECTION 2

SECTION 1

PARTS AND SUPPLIES

Locate the parts shown below and lay them out on the table in front of you. In addition to the parts included in the kit you will also need:

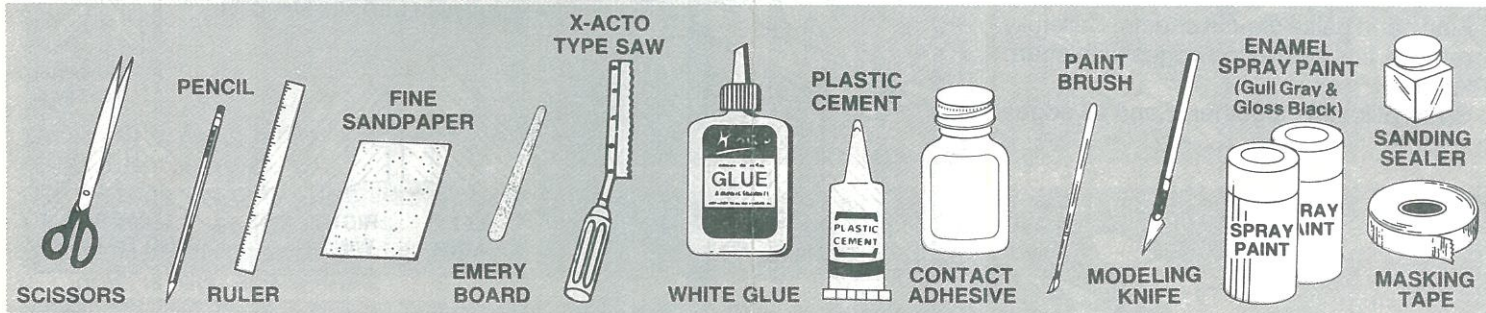

ASSEMBLY TIP

Read all instructions before beginning work on your model. Make sure you have all parts and supplies. Test-fit all parts together before applying any glue. If any parts don't fit properly, sand as required for precision assembly.

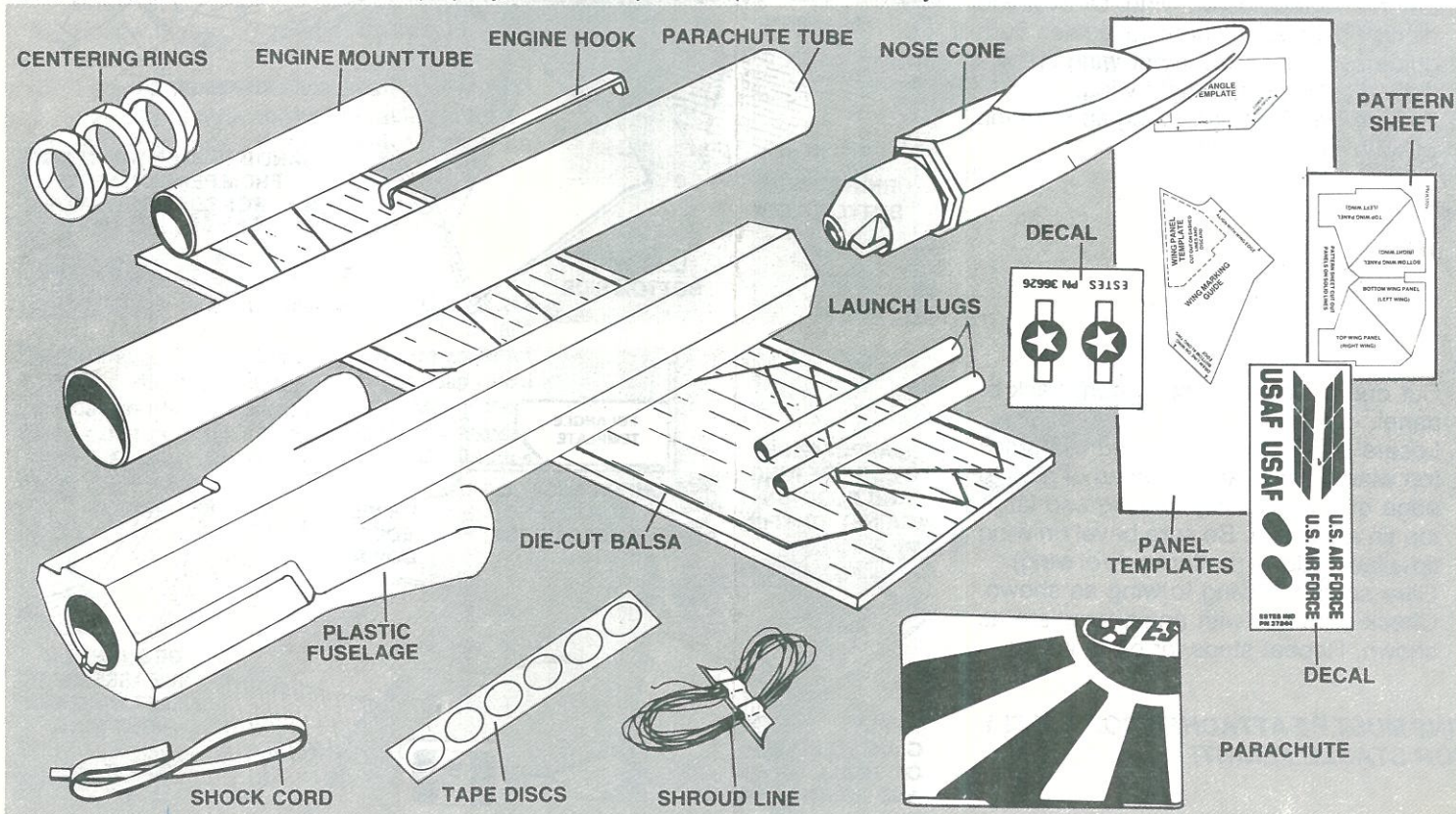

ROCKET ASSEMBLY

1

- Mark engine spacer tube $\frac{1}{4}$, $1\frac{1}{4}$, and $2\frac{1}{2}$ inches from end of tube.
- Cut $\frac{1}{8}$ inch slit at $2\frac{1}{2}$ inch mark.
- Sand inside edges of one centering ring. Cut a shallow $\frac{1}{8}$ inch wide slot inside ring.
- Insert one end of engine hook into slit.
- Slide slotted centering ring onto front of tube down to $\frac{1}{4}$ inch mark. Glue both sides of ring/tube joint.
- Cut a $\frac{1}{8}$ inch wide section out of another centering ring. Slide ring onto front of tube at $\frac{1}{4}$ inch mark. Glue both sides of ring/tube joint. Wipe away excess glue.

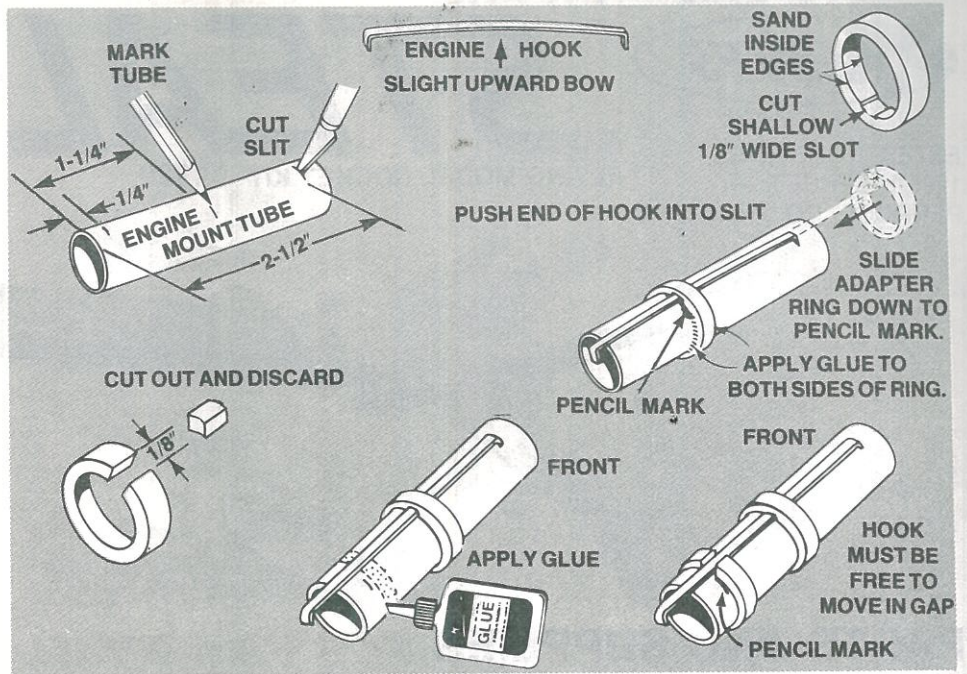

2

- Fine sand balsa die-cut sheets. Carefully remove fins by freeing edges with sharp knife.
- Stack alike fins together. Sand all edges smooth.

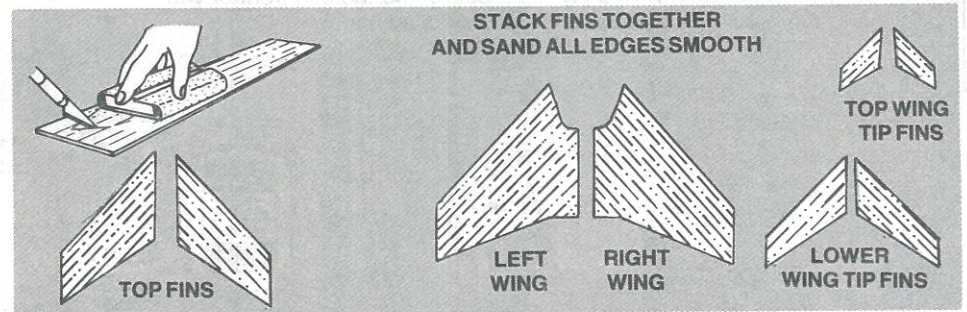

3

- Cut out wing marking guide from back of panel.
- Lay marking guide on wing. Draw a line along tip edge of marking guide. Turn guide over and mark other wing tip producing left wing and right wing.
- Sand a bevel on each wing tip from top of wing to pencil line.

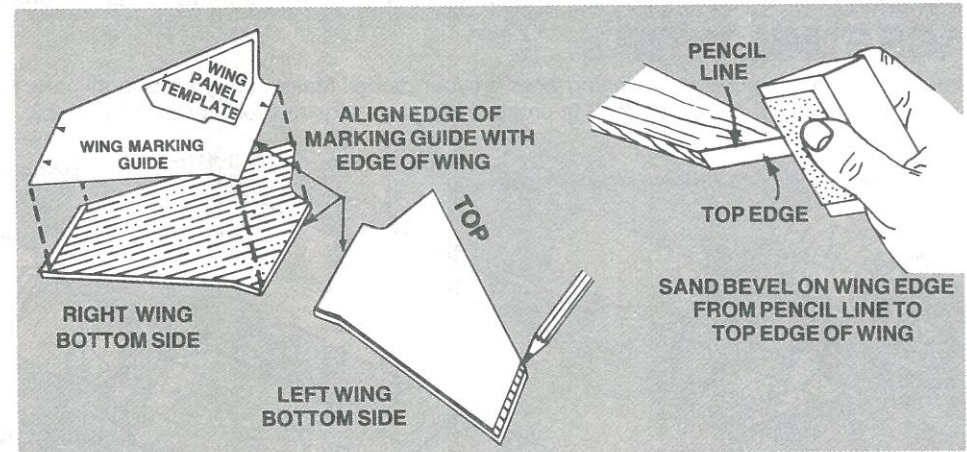

4

- Cut out fin angle template from back of panel.
- Locate two large top fins and two small top wing tip fins. Apply a bead of glue to edge of a wing and join wing and large top fin as shown. Be sure bevel on wing tip is facing down (bottom side of wing).
- Glue small top wing to wing as shown. Check both fins with angle template as shown. Repeat steps for other wing.

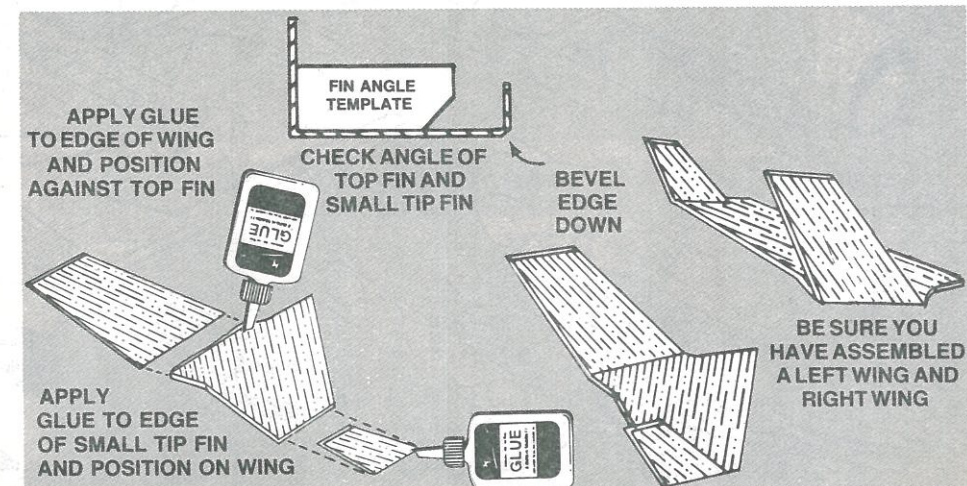

FINS MUST BE ATTACHED CORRECTLY FOR STABLE FLIGHT!

5

- Test-fit engine mount into parachute tube. Apply glue inside tube.
- Push engine mount in until centering ring is even with end of tube. Do not pause. Push in with smooth motion.

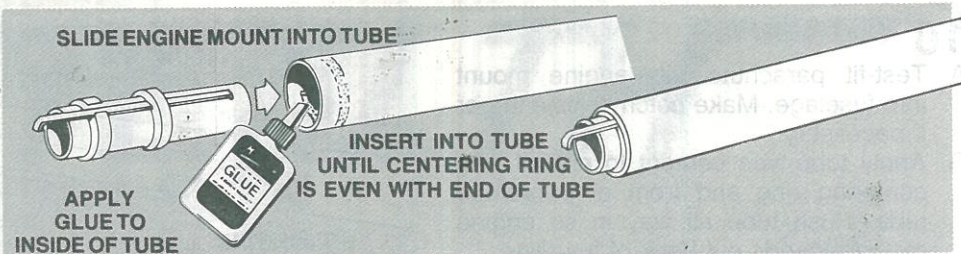

6

- Lightly score and cut off front and rear of plastic fuselage with X-Acto type saw.
- Sand small lip at front inside edge flush with inside surface of fuselage.
- Sand rear opening flush and clean plastic out of notch. Make notch deeper if necessary, to allow for engine hook.

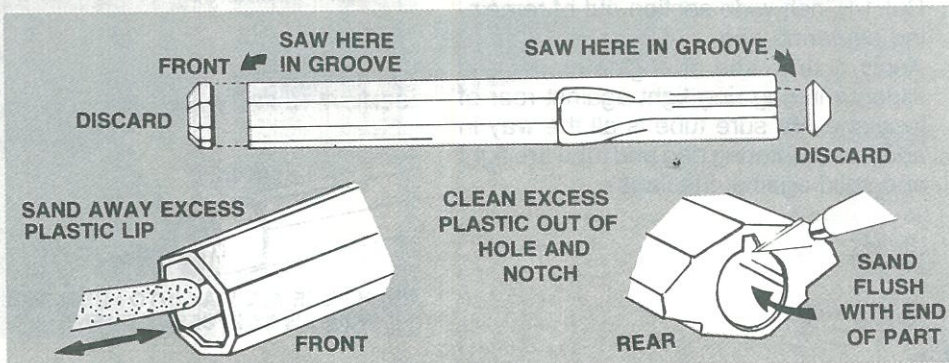

7

- Locate two remaining wing tip fins. Glue fins on bevel of wing. Check angle of fin with angle template.
- When glue has dried, apply a glue reinforcement to all wing/fin joints.

WINGS MUST BE ATTACHED CORRECTLY FOR STABLE FLIGHT!

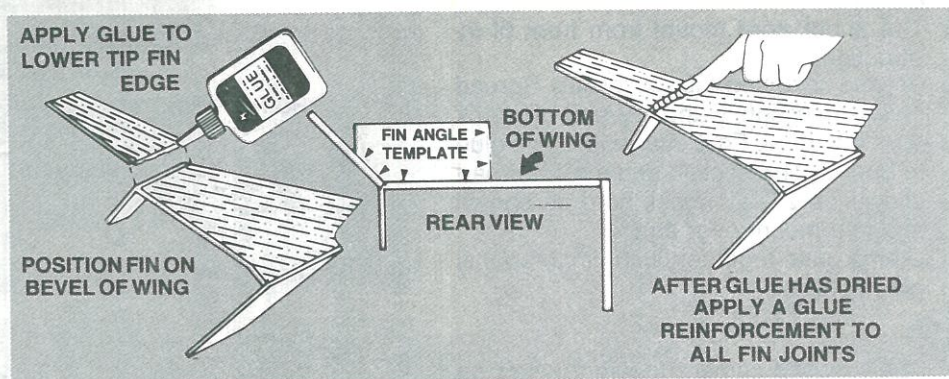

8

- Trim or sand excess plastic from around sides of fuselage and nose cone.
- Use sharp knife to remove excess plastic from eyelet on nose cone.

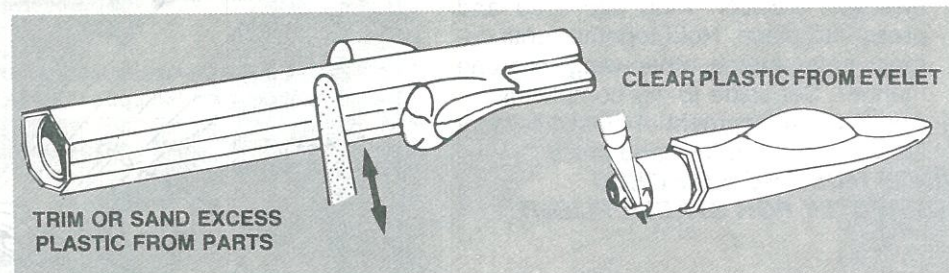

9

- Cut out wing panel template portion from wing marking guide. Mark location of wing panels on top and bottom of each wing.
- Cut out top and bottom wing panels from pattern sheet.
- Apply glue film to back of wing panels and position on wing. Press into place and hold until glue sets. Apply a small amount of glue to edges that might have lifted and press back down flat.

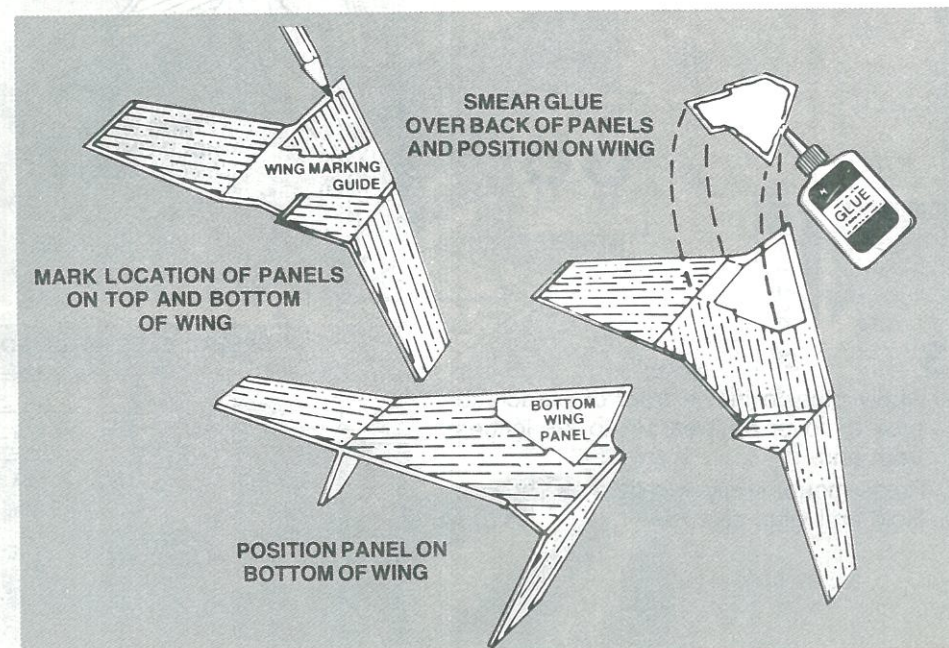

10

- Test-fit parachute tube/engine mount into fuselage. Make notch or hole larger if necessary.
- Apply tube-type cement to end of rear centering ring and front of parachute tube. Push tube all way in so engine mount extends out back of fuselage.
- Cut 1/8 inch wide section out of remaining centering ring.
- Apply glue to end of engine mount and slide centering ring tight against rear of fuselage. Be sure tube is all the way in and both centering ring and tube are tight and solid against fuselage.

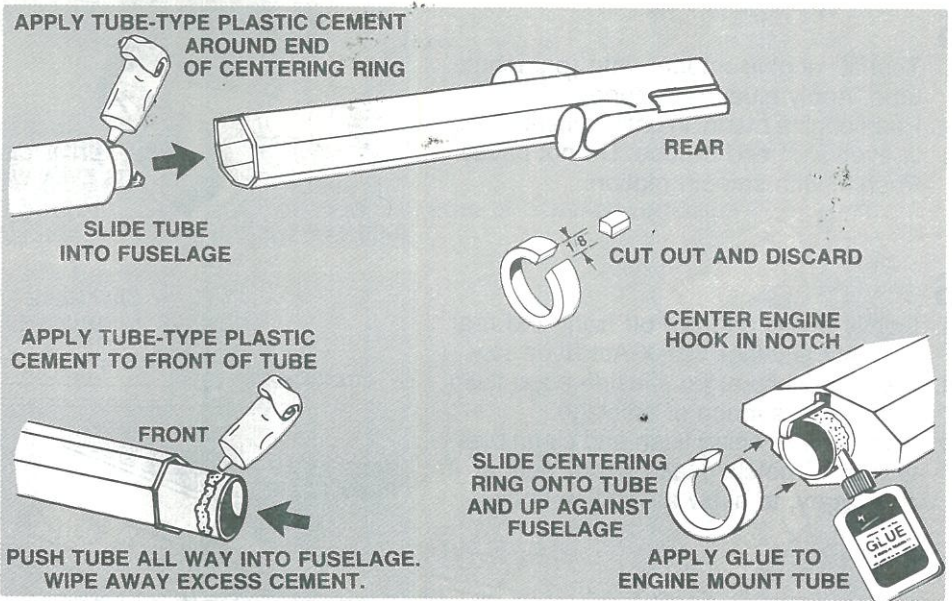

11

- Cut shock cord mount from front of instructions.
- Crease on dotted lines by folding. Spread glue on section 1 and lay end of shock cord into glue. Fold over and apply glue to back of first section and exposed part of section 2. Lay shock cord as shown and fold mount over again.
- Clamp unit together with fingers until glue sets.

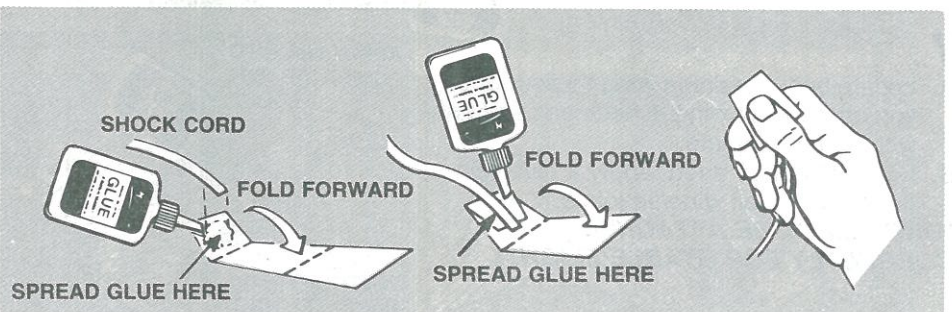

12

- Apply plastic cement to wing mount on fuselage. Position wing into area and press into place. Hold together until cement sets. Attach other wing in same manner. Set aside to dry completely.
- Apply a reinforcement of plastic cement around wing and fuselage joints.

WINGS MUST BE ATTACHED CORRECTLY FOR STABLE FLIGHT!

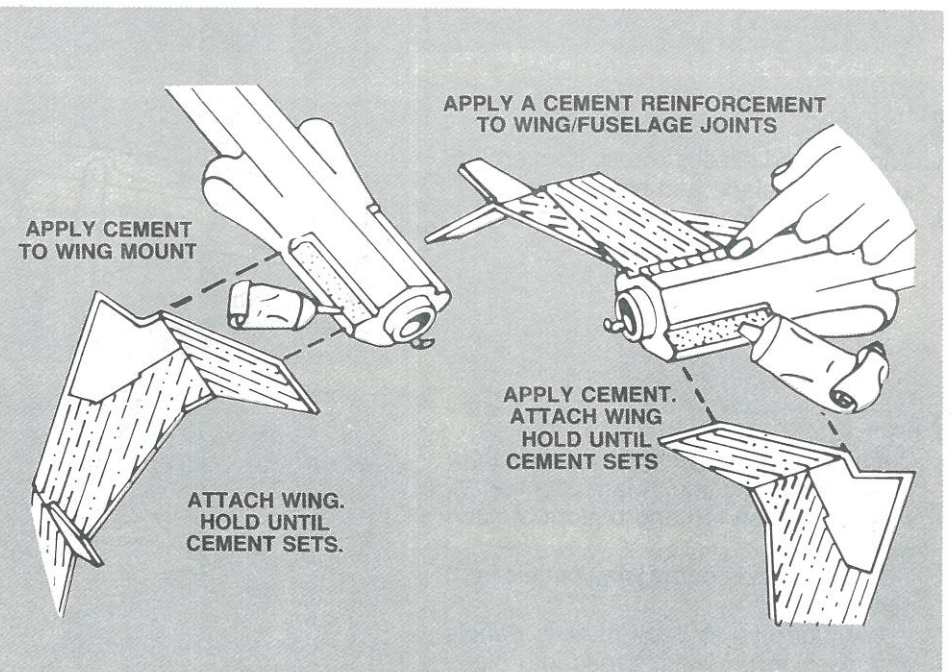

13

- Apply glue to inside front of parachute tube to cover an area 1½ to 2½ inches from end.
- Press mount firmly into glue as shown.
- Hold until glue sets.

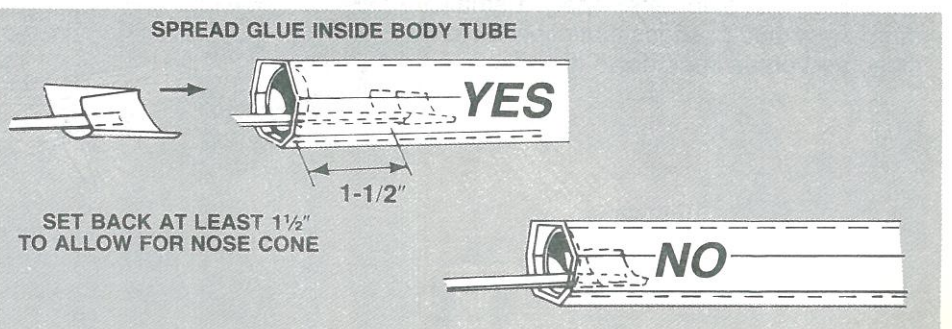

14

- Apply contact adhesive in two grooves on fuselage.
- Center each launch lug in groove and press it firmly into adhesive.
- Allow adhesive to dry, and apply a reinforcement of plastic cement to each launch lug.

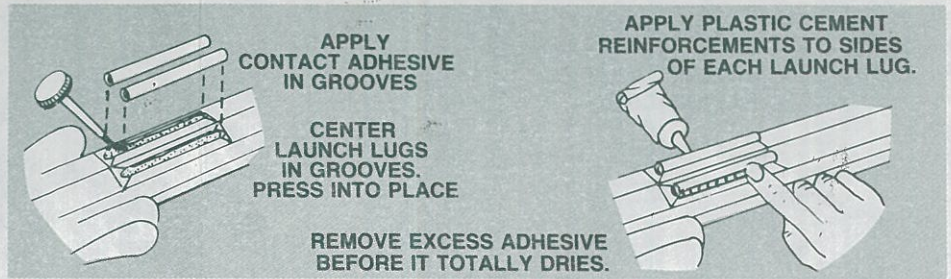

15

- Cut out parachute on edge lines.
- Cut three 24 inch lengths of shroud line.
- Form small loops with shroud line ends and press onto sticky side of tape discs.
- Attach tape discs with line ends to top of parachute as shown.
- Firmly press tape discs into place until both tape discs and parachute material are molded around shroud line loops.
- Pass shroud line loops through eyelet on nose cone. Pass parachute through loop ends and pull lines against the nose cone.
- Tie free end of shock cord to nose cone eyelet.

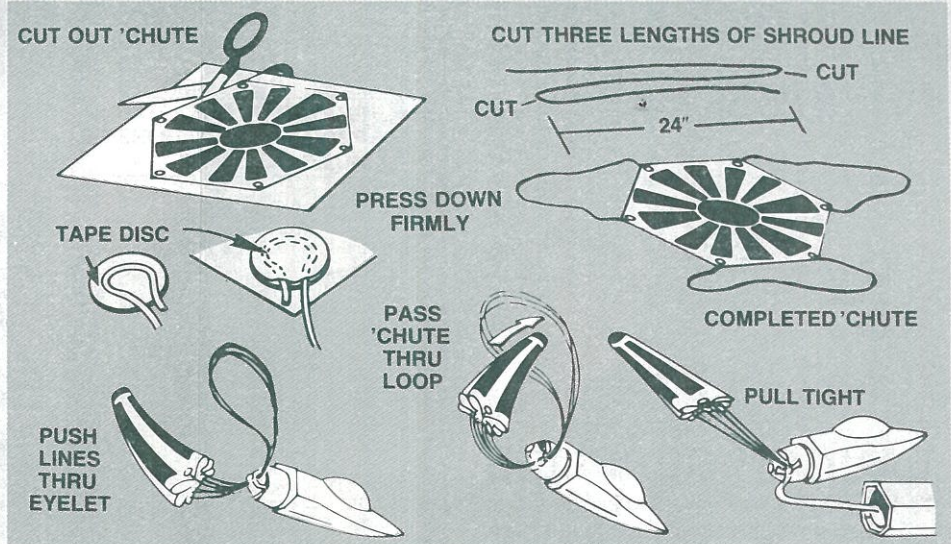

16

- Apply sanding sealer to all wood parts with small brush.
- When sealer is dry, lightly sand all sealed surfaces.
- Repeat sealing and sanding until wood grain is filled and smooth.

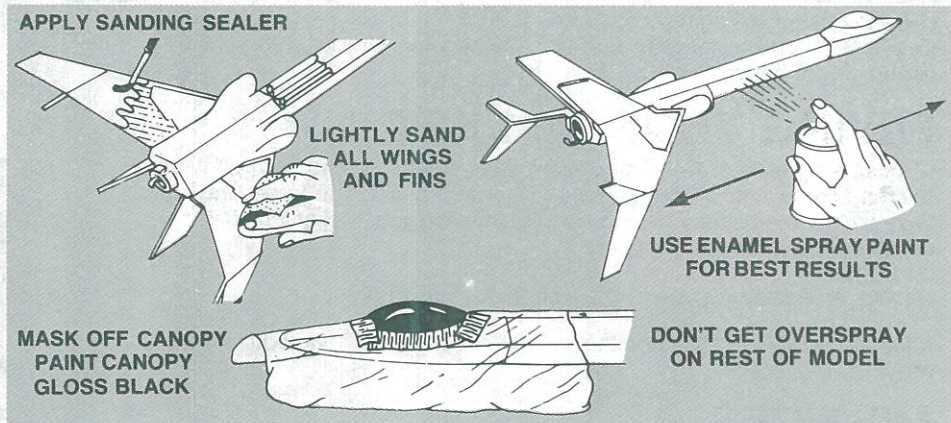

17

- When sanding sealer and glue are completely dry, paint model with Gull Gray enamel.
- Follow instructions on spray can for best results.
- Let dry overnight. Mask off rocket and paint canopy with gloss black enamel.
- Remove mask from rocket as soon as paint has set.

FINISHING YOUR ROCKET

Apply decals in the position shown. Cut decals apart, trimming excess clear as close to details as possible. Dip one decal in lukewarm water for 20 seconds and hold until it uncurls. Slip decal off backing sheet and onto model. Move decal into exact position. Carefully blot away excess water. Smooth out any wrinkles or air bubbles with a soft cloth.

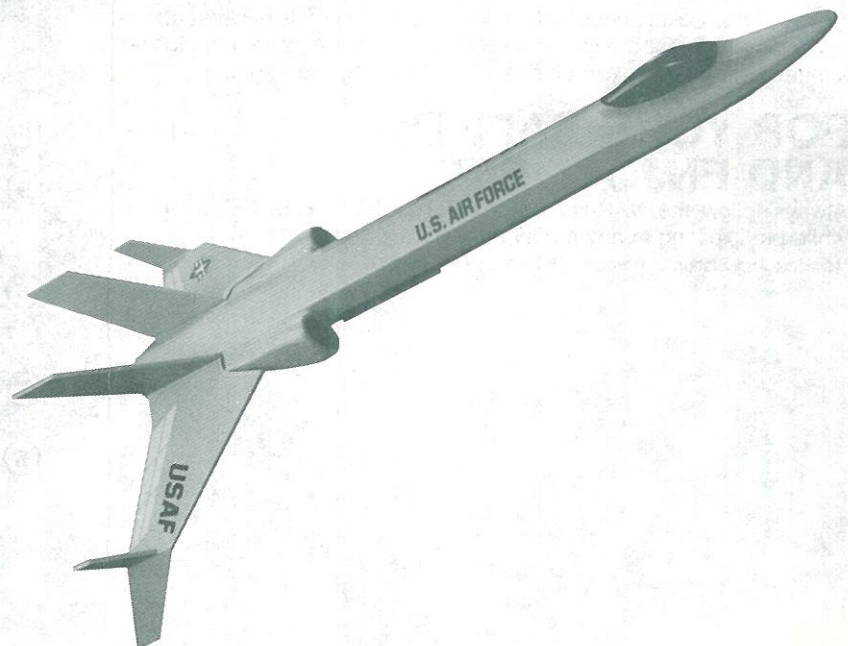

ROCKET PREFLIGHT

CRUMPLE AND INSERT 3 SQUARES OF RECOVERY WADDING

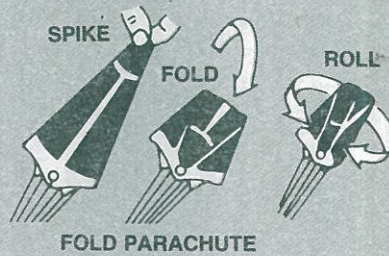
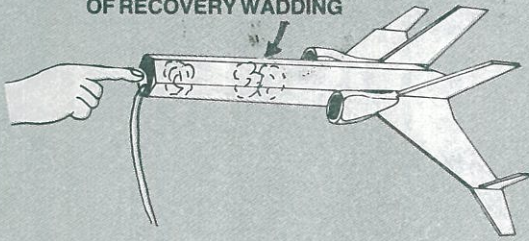

FOLD PARACHUTE

WRAP LINES LOOSELY AROUND 'CHUTE

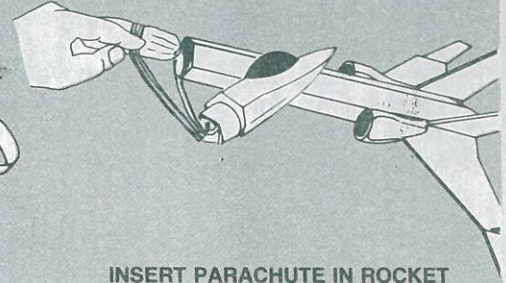

INSERT PARACHUTE IN ROCKET

PREPARE ENGINE

SEPARATE THE IGNITERS



ENGINE

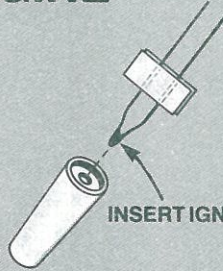

INSERT IGNITER

IGNITER TIP MUST TOUCH PROPELLANT DEEP INSIDE NOZZLE OPENING



FOLD OVER AND BEND TIPS

APPLY AND FIRMLY PRESS TAPE DISC OR MASKING TAPE IN PLACE



INSTALL ENGINE IN ROCKET



HOOK MUST LATCH OVER END OF ENGINE

LAUNCH SUPPLIES

To launch your rocket you will need the following items:

- An Estes model rocket launching system
- Estes Recovery Wadding (No. 2274)
- Recommended Engines: A8-3, B4-4, B6-4, C6-3, C6-5

Use a B4-4 engine for your first flight to become familiar with your rocket's flight pattern.

FLYING YOUR ROCKET

Choose a large field away from power lines, tall trees, and low flying aircraft. Try to find a field at least 250 feet square. The larger the launch area, the better your chance of recovering your rocket. Football fields and playgrounds are great.

Launch area must be free of dry weeds and brown grass.

Launch only during calm weather with little or no wind and good visibility.

MISFIRES

Failure of the rocket engine to function properly is nearly always caused by a failure to install the igniter correctly. This failure permits the igniter to heat and burn into two pieces without igniting the engine.

FOR YOUR SAFETY AND ENJOYMENT

Always follow the NAR-HIA* MODEL ROCKETRY SAFETY CODE while participating in any model rocketry activities.

*National Association of Rocketry-The Hobby Industry of America

COUNTDOWN AND LAUNCH

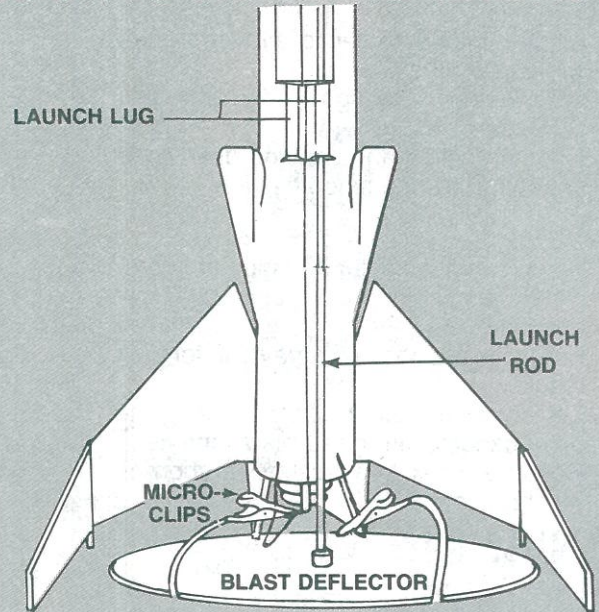

- 10 REMOVE SAFETY KEY to disarm the launch controller.
- 9 Remove safety cap and slide launch lug over launch rod to place rocket on launch pad. Make sure the rocket slides freely on the launch rod.
- 8 Attach micro-clips to the igniter wires. Arrange the clips so they do not touch each other or the metal blast deflector. Attach clips as close to protective tape on igniter as possible.
- 7 Move back from your rocket as far as launch wire will permit, (at least 15 feet).
- 6 INSERT SAFETY KEY to arm the launch controller.

Give audible Countdown 5...4...3...2...1

LAUNCH!! PUSH AND HOLD LAUNCH BUTTON UNTIL ENGINE IGNITES

Remove safety key—Replace cap on rod.