

# NEBULON WARRIOR

SKILL LEVEL 3 - Recommended for Advanced Rocketeers

## BEFORE YOU START

Read each step and study the accompanying drawings before doing any of the work called for in that step. Make sure you have all parts and materials. Check off each step as you complete it. Always test-fit parts together before applying glue. It will sometimes be necessary to sand edges of rings, tubes, etc. to obtain proper fit. If you are in doubt about the relative size or location of some parts, refer back to this exploded view drawing for clarification. Adequate glue joints are very important for a flying model rocket. Follow the instructions carefully in this regard.

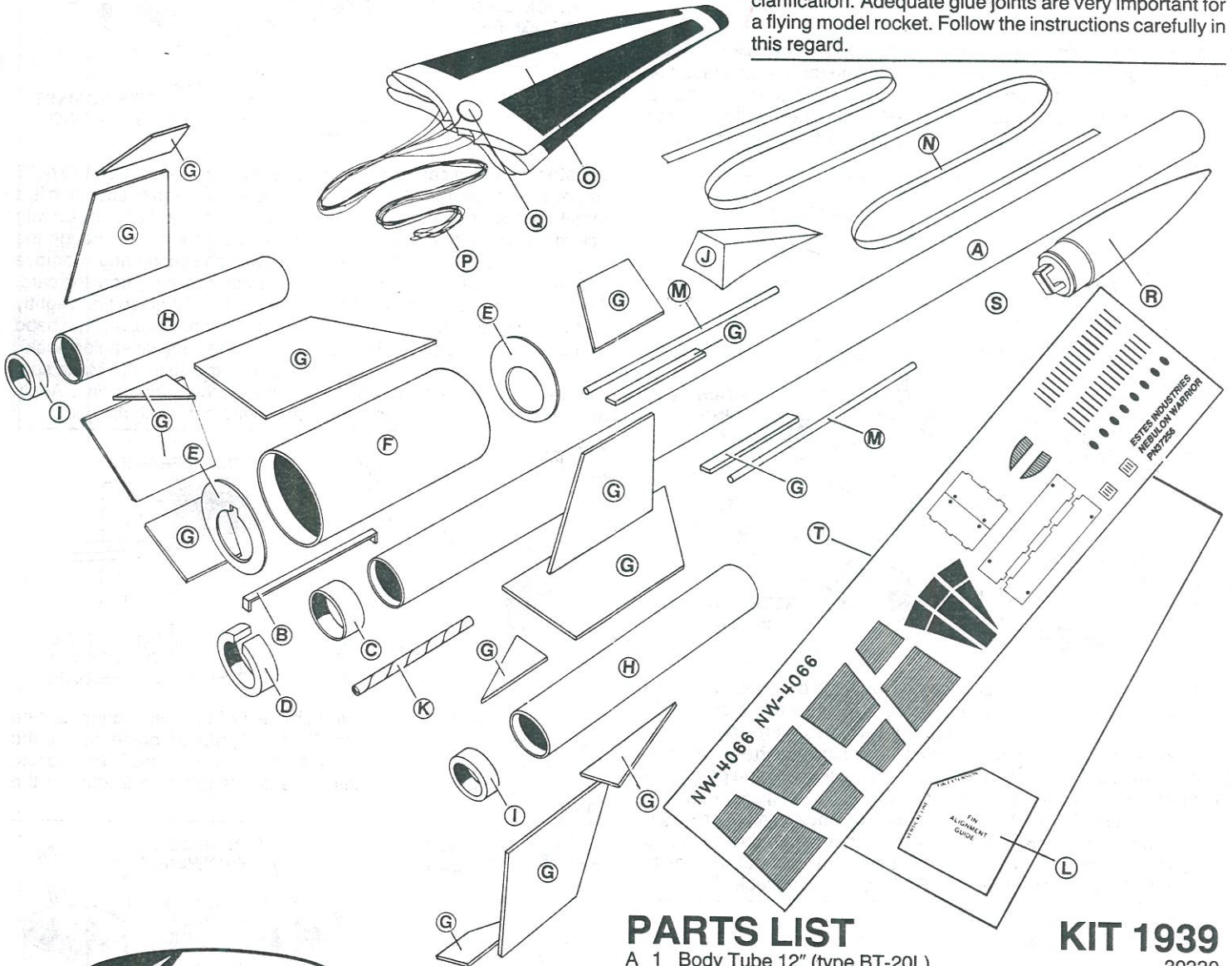

A DAMON COMPANY

**ESTES INDUSTRIES**  
PENROSE, CO 81240 USA

### RECOMMENDED ENGINES

A8-3, B4-4 (1st flight), B6-4, B8-5, or C6-5

## TOOLS AND MATERIALS

In addition to the parts included in this kit you will need: Scissors, tweezers, pencil, ruler, fine or extra-fine grit sandpaper, sanding sealer, a medium-size modeling paint brush, modeling knife with sharp blade, Pactra rebel gray spray paint, plastic model cement and household white glue or resin glue (Elmer's, Titebond, or similar). Other types of glue are not recommended.

## PARTS LIST

## KIT 1939

A	1	Body Tube 12" (type BT-20L)	30330
B	1	Engine Hook (type EH-2)	35025
C	1	Retainer Ring (type HR-20)	30168
D	1	Split Centering Ring (type AR-2050S)	80425
E	1	Die-Cut Card (type RA-1366)	32470
F	1	Body Tube 2 3/4" (type BT-55J)	30386
G	1	Balsa Die-Cut (type BF-1939)	32639
H	2	Body Tube 4" (type BT-20DJ)	30332
I	2	Centering Ring (type AR-520)	30162
J	1	Printed Cockpit	83345
K	1	Launch Lug (type LL-2B)	38178
L	1	Alignment Guide (back of kit panel)	83746
M	1	Dowel 1/12 x 6"	85912
N	1	Shock Cord (type SC-1)	85730
O	1	Parachute (type PK-12A)	85564
P	1	Shroud Line (type SLT-72)	38237
Q	1	Tape Discs (type TD-3F)	38406
R	1	Nose Cone (type PNC-20A)	72602
S	1	Nose Cone Base (type PIN-20A)	72603
T	1	Decal (type KD-1939)	37256

# ASSEMBLY INSTRUCTIONS

1

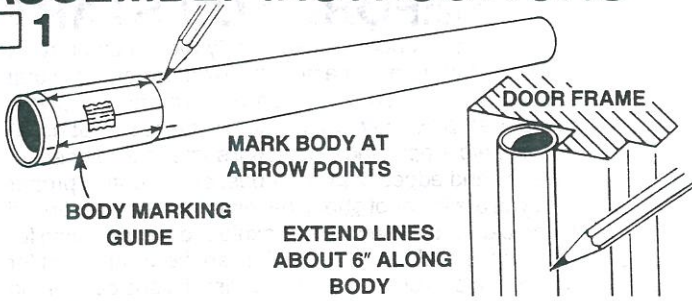

Cut the BT-20 marking guide from page 7 of these instructions. Wrap the guide around the 12" long BT-20L body tube (part A) and tape the ends together. Mark the body tube at each of arrow points. Remove the guide and lay it aside (it will be used again later). Using a door frame as a guide, draw lines connecting the marks. Extend the lines about 6" from the end of the tube.

2

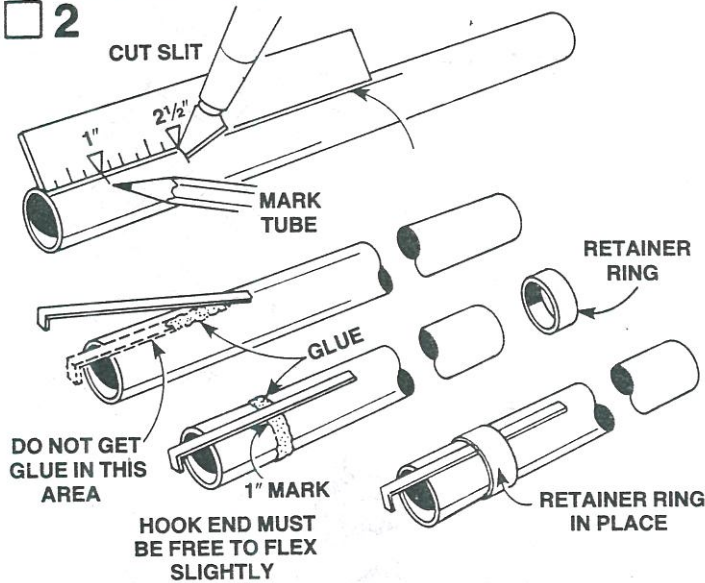

Lay a ruler on one of the pencil lines and mark the body tube at 1" and 2 1/2" from the end. Cut a 1/8" long slit across the tube at the 2 1/2" mark. Apply a bead of glue on the pencil line between the slit and the 1" mark. Press one end of the engine hook (part B) into the slit. Press the hook down into the glue, making sure the hook is centered on the pencil line and that it runs straight along the body. Apply a line of glue around the body tube just FORWARD of the 1" mark. Slip hook retainer ring (part C) onto front end of tube. Slide ring rearward, over engine hook and UP TO the 1" mark. The overhanging engine hook end must be free to flex slightly. Be sure that hook runs STRAIGHT along tube.

3

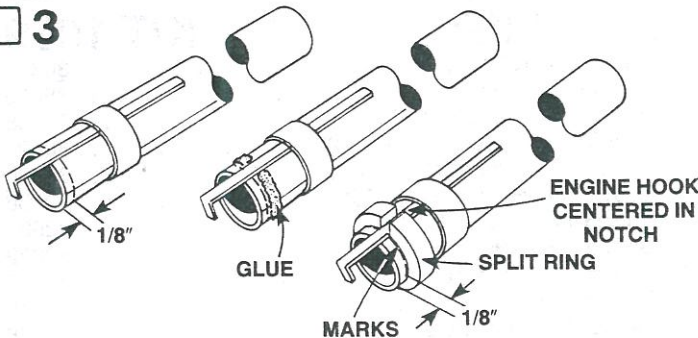

Mark the body tube 1/8" from the rear end. Place several marks around the tube so the centering ring may be accurately aligned. Apply glue around the tube above the marks, being careful not to get glue on the engine hook. Slide the split centering ring (part D) onto the tube and position ring with its rear edge on the marks. Hold ring in place until glue begins to set.

4

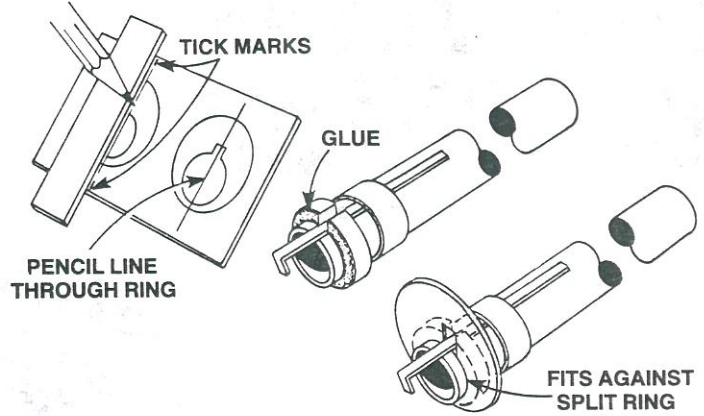

Locate the die-cut card containing the adapter rings (part E). DO NOT remove the rings from the card. At the top and bottom of each ring is a small tick mark cut into the card. Lay a ruler on the card and line up with tick marks on one ring. With a sharp pencil, draw a line through the ring, EXACTLY on the tick marks. Repeat with second ring. Remove the ring that has the notch in the top of the inner opening from the card. Test-fit this ring onto the rear of the body tube. If it is too tight, lightly sand the inside of the opening until a good fit is obtained. Apply a bead of glue to the rear edge of the split ring (don't get glue on engine hook). Slide the adapter ring onto the body against the split ring. Make sure the engine hook is centered in the notch in the adapter ring. Apply another bead of glue around the adapter ring-centering ring joint.

5

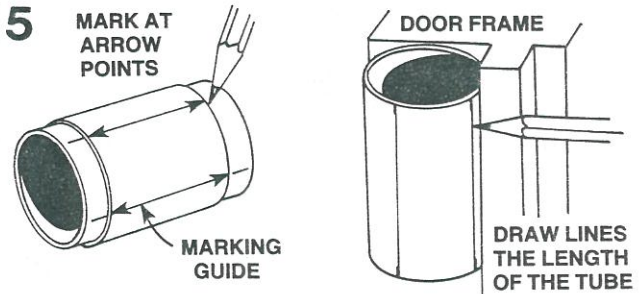

Cut the BT-55 marking guide from page 7 of the instructions. Locate the 2 3/4" long BT-55J body tube (part F). Wrap the guide around the body and tape the ends together. Mark the tube at the arrow points. Remove guide and draw lines the entire length of the tube on the marks.

6

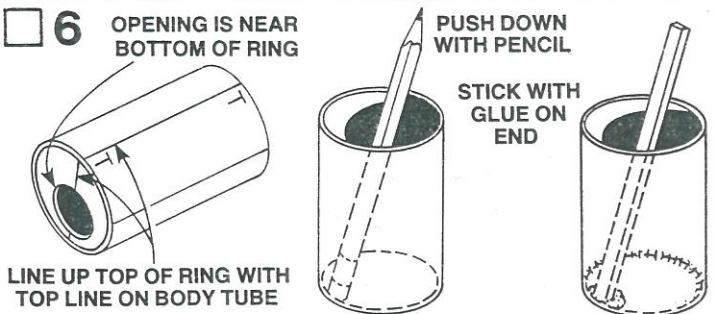

Print the letter 'T' at both ends of the body, next to one of the lines. This indicates that this line is at the top of the body. Insert the remaining adapter ring into one end of the body. Rotate the ring until the top center line of the ring is lined up exactly with the top ('T') line on the body. Study the drawing carefully to make sure you have done this correctly. Place the body tube, with the ring end down, on a flat surface. Hold the body tube firmly on the surface and push down all around the edges of the ring with the eraser end of a pencil. This will position the ring exactly inside the end of the tube. Using a stick as an applicator, apply a bead of glue all around the inside of the ring/body tube joint. Be careful that you do not push the ring from the end of the tube. Set aside to allow glue to dry.

**7** LIGHTLY SAND BOTH SIDES OF BALSA SHEET

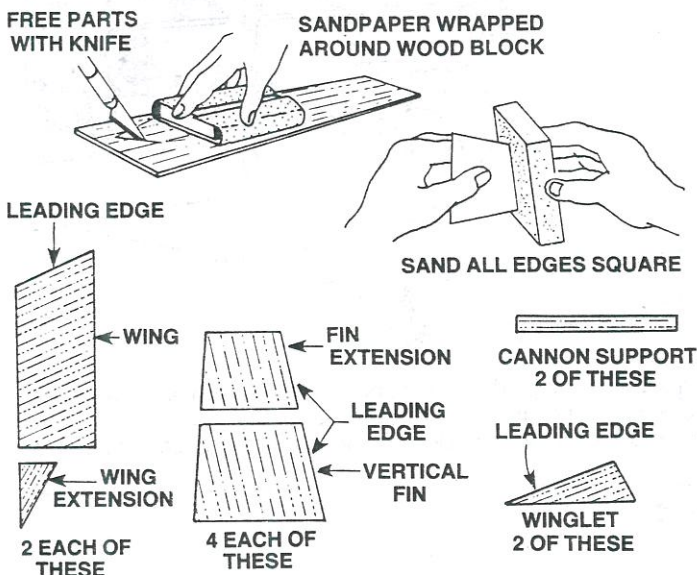

Lightly sand both sides of the balsa die-cut sheet (part G). Carefully free the parts from the sheet using a hobby knife. Lightly sand the edges of all parts, making sure the edges remain square. Lay out and identify the parts as shown above. Note that the balsa grain line runs parallel to the leading edges of the parts.

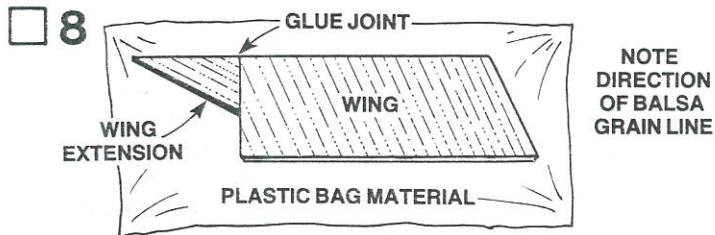

Cut a 2" x 4" piece of material from the plastic kit bag. Lay a wing on the plastic. Lay a wing extension on the plastic and line up with the wing so it looks just like the drawing. Pick up the wing extension and apply glue to the edge that joins the wing. Lay the extension in place again and press against the wing. Make sure the top edges of the parts are even. Allow glue to dry a few minutes, then smear a thin film of glue across the joint with your finger. Allow the glue to dry completely, then turn assembly over and apply a thin film of glue to the other side of the joint. After the glue has dried, lightly sand both sides of the joint. Assemble a second wing unit in the same manner.

**9** SAND EDGE OF RING IF NECESSARY FOR FIT

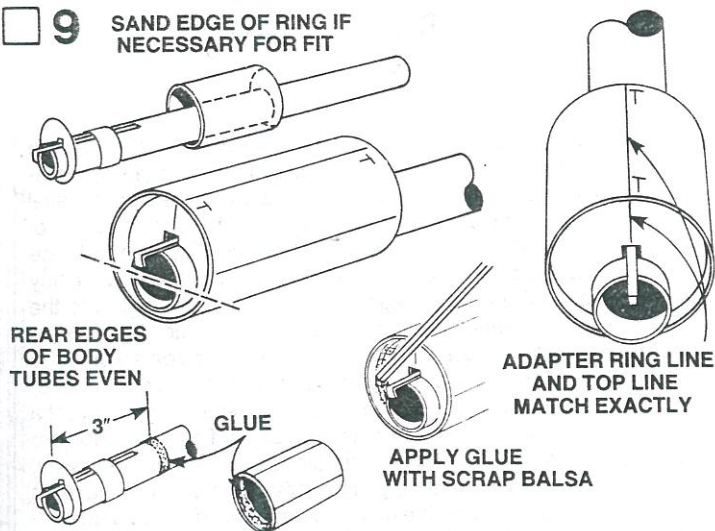

The glue should now be dry on the body tube/adapter ring joint (Step 6). Test-fit the body tube assemblies together as shown. If the rear adapter ring won't slide into the BT-55 tube, sand the edges of the ring

to obtain a sliding fit. Before applying any glue, note how the assemblies fit together. The rear adapter ring fits slightly inside the BT-55 body tube so that the rear edges of both body tubes are even. The top of the rear adapter ring is aligned with the top line. Apply a bead of glue around the main body tube about 3" from the rear of the tube. Apply another bead of glue around the inside of the rear of the BT-55 tube. Assemble the parts as described above. Make all adjustments quickly before the glue begins to set. Allow the glue to set for a few minutes, then apply a bead of glue around the rear adapter ring/body tube joint, using a piece of scrap balsa for an applicator.

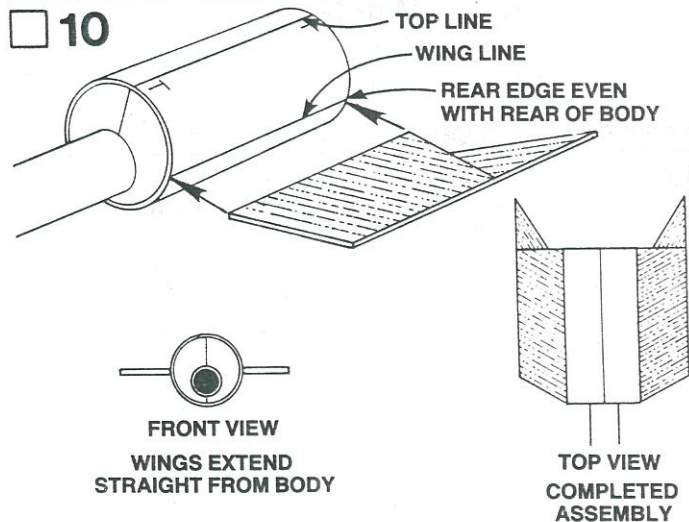

Test fit a wing to the body as shown. Make sure you have the wing positioned just as shown in the drawing. Apply glue to the inside edge of the wing and attach to the body, centered on the wing line. Make sure the wing points straight out from the body. Support with the wing pointing straight up until the glue dries. Attach the other wing to the opposite side of the body in the same manner.

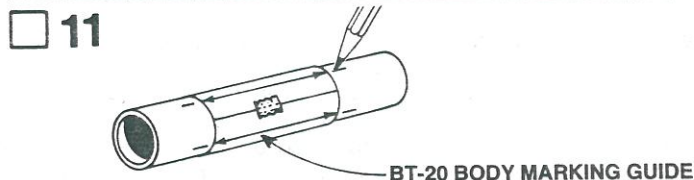

Wrap the BT-20 marking guide (from Step 1) around one of the 4" long BT-20 DJ body tubes (part H). Mark the arrow points on the tube. Remove guide, wrap around second BT-20DJ and mark arrow points on that tube. Place each tube against a door frame and draw lines (at the marks) the entire length of the tube.

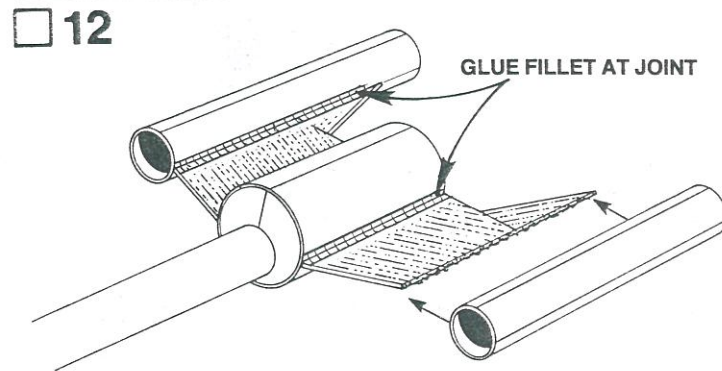

Apply a bead of glue to the outer edge of one wing. Attach one of the BT-20DJ tubes to it with a pencil line centered on the wing and the front edges of wing and tube even. Hold the assembly until the glue begins to set, then attach the second tube to the opposite wing. After the glue has dried, apply a bead of glue to both sides of the joints where the 3 body tubes join the wings. Smooth the glue into an even fillet with your finger.

13

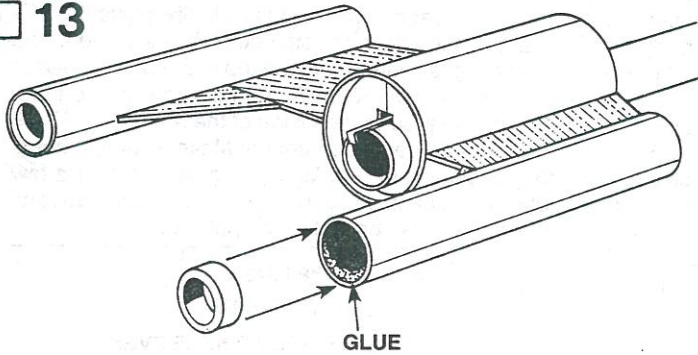

Glue the two AR-520 rings (part I) into the rear of the BT-20DJ tubes.

14

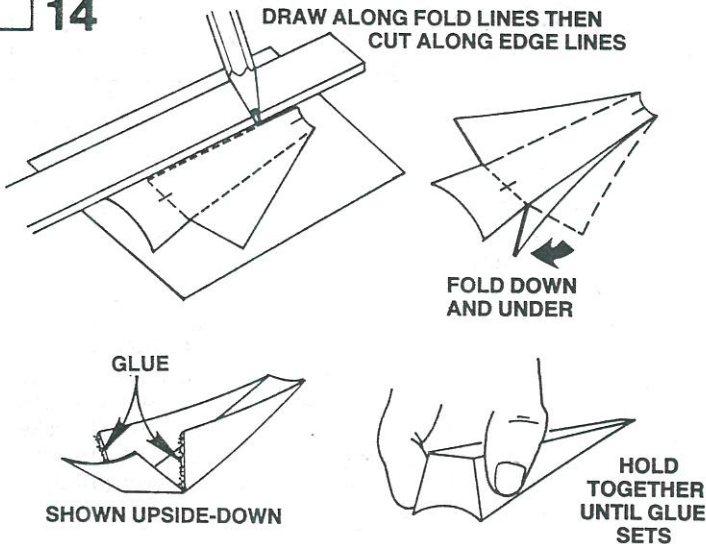

Locate the card with the cockpits printed on it (part J). Only one cockpit is needed, the other is a spare in case you make a mistake. Using a sharp **HARD LEAD** pencil and a ruler for a guide, draw lines along the three dotted fold lines. Press down a bit so it will form a good crease line. Carefully cut out the cockpit along the solid edge lines. Fold one side down and under. By folding farther than you need to, the folded portions will stay in place when glue is applied. Fold the other side and the back in the same manner. Partially unfold and apply a very **SMALL** amount of glue to the **INSIDE** rear edges of the sides. Fold the back so it fits between the sides. Hold the assembly together until the glue begins to set. Place aside to allow glue to dry.

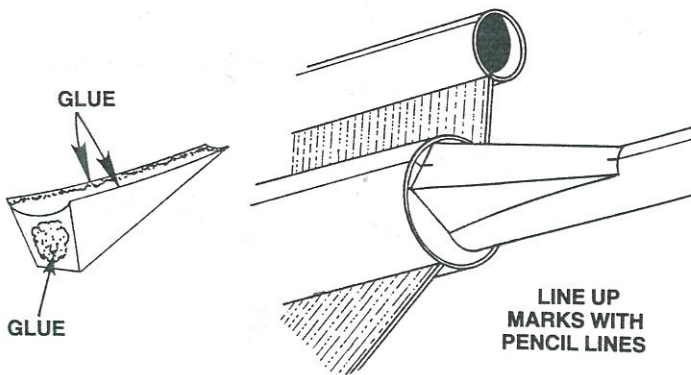

Proceed with this step only after the glue on the cockpit is completely dry. Apply a bead of glue to the inside edge of each side and to the back of the cockpit. Set the cockpit in place as shown (note how marks on cockpit line up with pencil lines on body). Hold the sides of the cockpit against the body until the glue sets. Use a small stick or toothpick to apply a thin bead of glue all around the body-cockpit joints. Run your little finger along the joints to smooth out and remove excess glue.

16

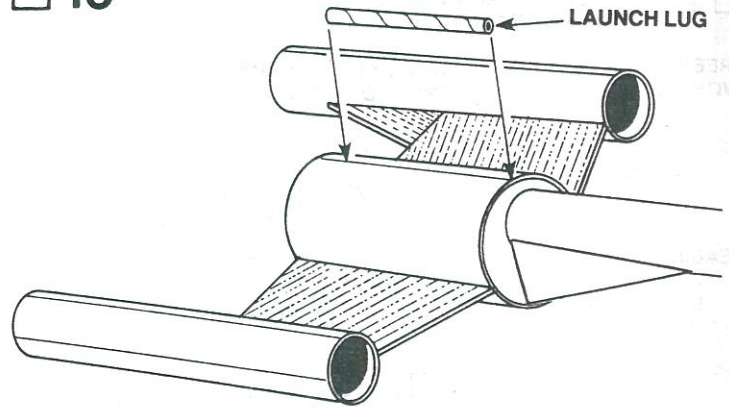

Glue the launch lug (part K) to the bottom of the BT-55 body, centered on the bottom pencil line, with the front of the body and lug even. Apply a light bead of glue to both sides of the launch lug to strengthen the joint.

17

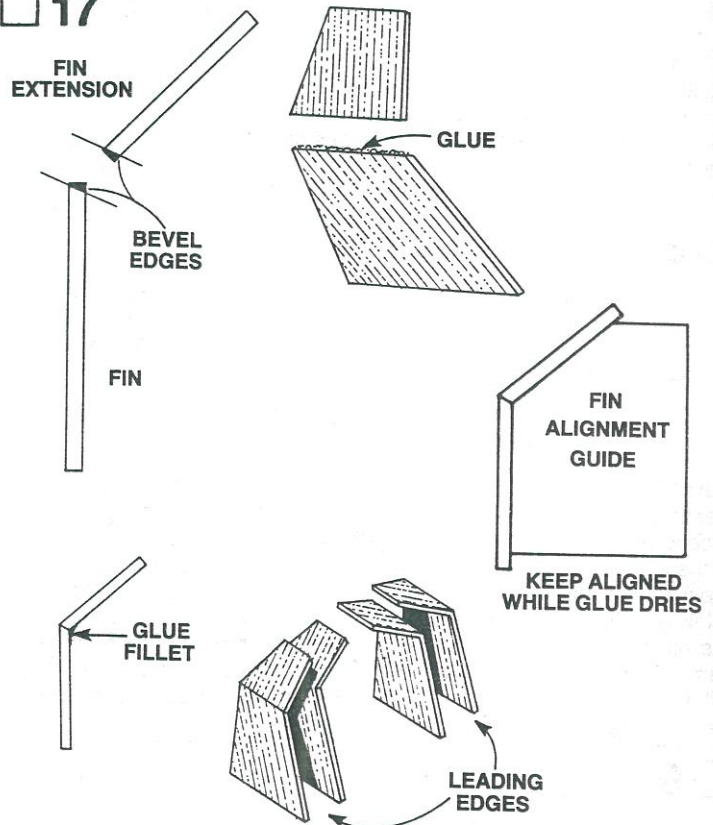

Cut the fin alignment guide (part L) from the back of the panel. Lay out a fin and a fin extension with the leading edges pointing the same direction (refer to step 7). Remember, the balsa grain line runs parallel to the leading edge. Use a sanding block to bevel the mating edges of the two parts. Place the edges together and check alignment with the guide. If necessary, sand more or less angle to the the edges until they make a tight joint when placed against the guide. Apply glue to the edge of the fin and press the extension against it. Hold the parts together for a couple of minutes. Place the alignment guide against the assembly. Adjust the angle of the parts to match the guide. Hold together until the glue sets. Lay the fin assembly aside and construct a second in exactly the same manner. The other two fin assemblies are built in the same way except the fin extensions point the opposite way. Study the drawing and make sure you understand this before building the last two assemblies. After the glue is completely dry, run a bead of glue along the inside of each joint and smooth into an even fillet with your finger. Run a lighter bead of glue along the outside of each joint. Rub the glue into the joint and wipe away all excess glue with your finger.

18

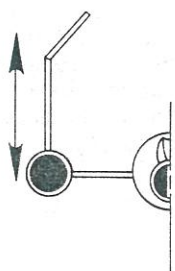
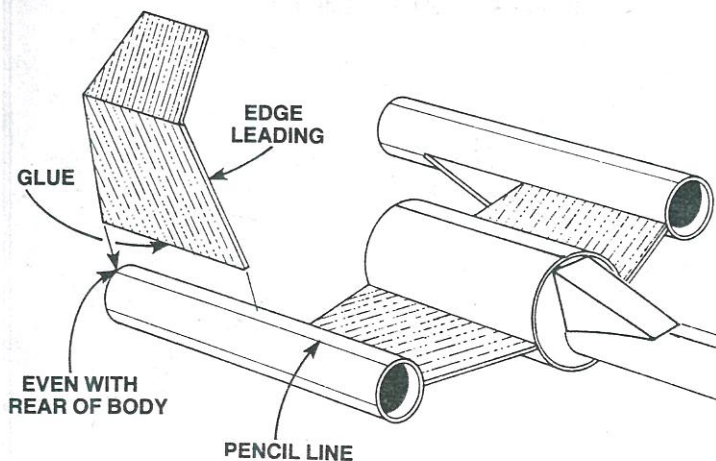

FIN POINTS STRAIGHT UP

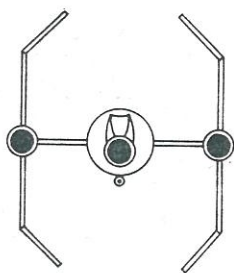

FRONT VIEW COMPLETED ASSEMBLY

When attaching fin assemblies, keep in mind that the leading edges face forward and the angled portions of the fins point in toward the center of the body. Glue the fin assemblies in place one at a time, holding the fin in place pointing straight up or down until the glue sets. After the glue joints are completely dry, apply glue reinforcement fillets to all joints.

19

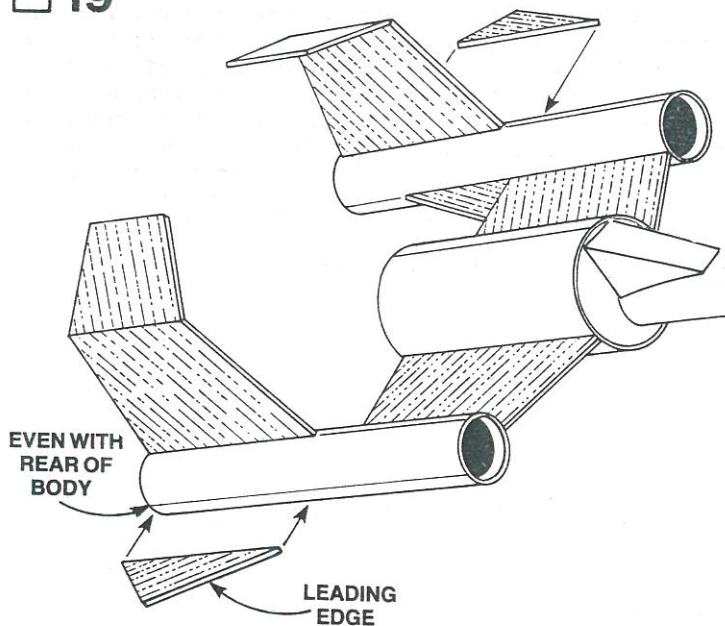

Glue the two winglets to the outside of the BT-20DJ tubes. Apply glue fillets along joints.

20

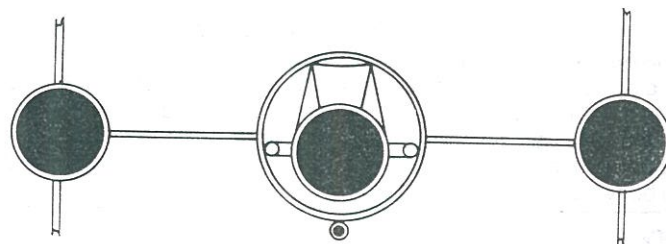
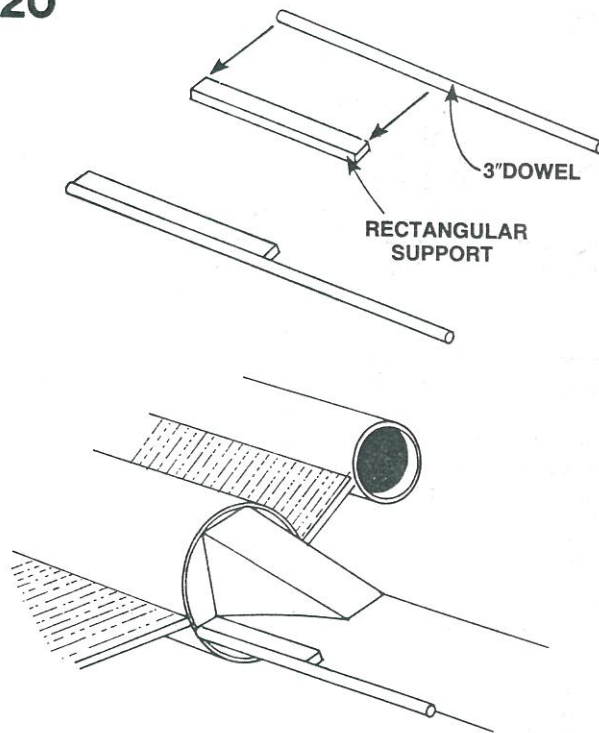

FRONT VIEW

Cut the 6" dowel (part M) into two 3" lengths. Glue a rectangular support to each dowel. Glue the assemblies to the body on the guide lines on either side of the cockpit.

21

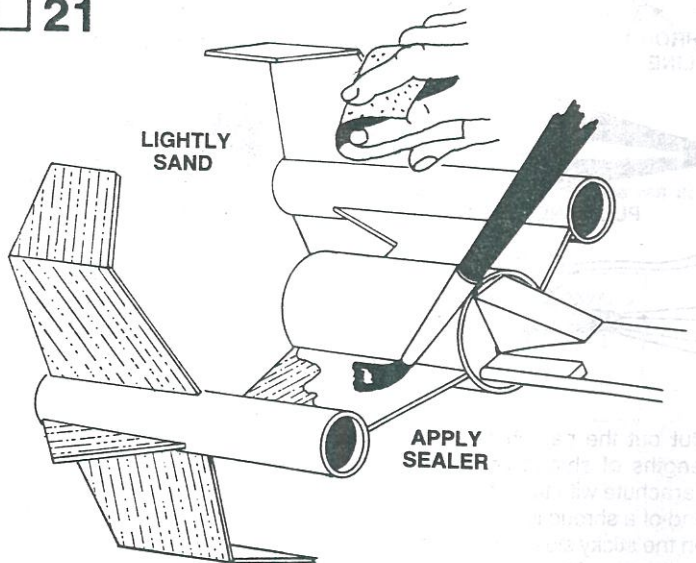

Seal all balsa parts with sanding sealer. Allow the sealer to dry and lightly sand the parts. Seal and sand again. A third or even fourth application may be necessary to achieve a smooth, grain-free surface.

**22**

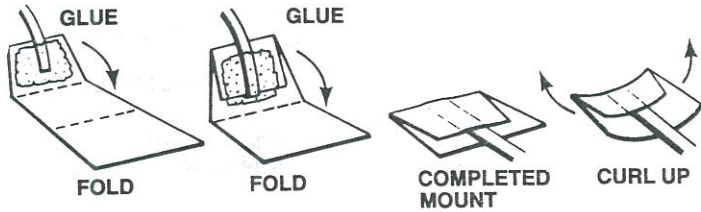

Cut out the shock cord mount from page 7 of the instructions. Fold on dotted lines, then unfold and apply glue to Sec. 1. Lay the end of the shock cord (part N) in the glue. Fold over and apply glue to the back of Sec. 1 and the exposed part of Sec. 2. Fold again to complete mount. Curl the edges of the mount up so it will match the contour of the body tube and hold with your fingers until the glue sets.

**23**

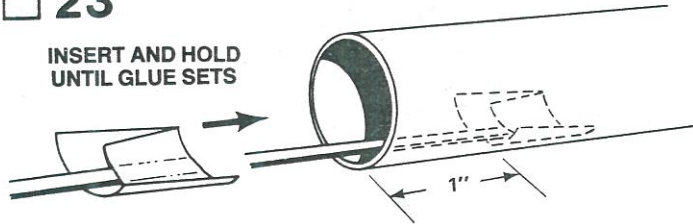

The shock cord is glued into the front of the body tube 1" from the end. This allows clearance at the front of the tube for the nose cone to socket into place. Use a stick to deposit a generous dab of glue inside the body tube, 1" from the end. Slide the shock cord mount into the tube and press into the glue. To insure a good bond, use the stick or your finger to smear a film of glue over the mount and the surrounding area in the body tube.

**24**

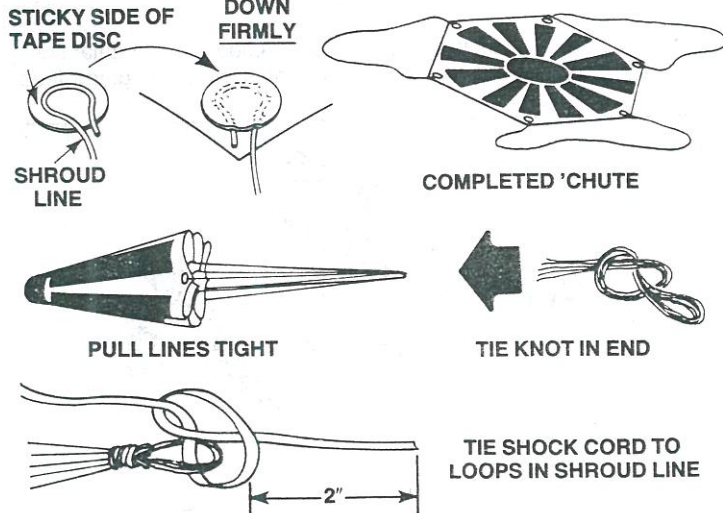

Cut out the parachute (part O) on its edge lines. Cut three equal lengths of shroud line (part P). Attach line ends to the top of the parachute with tape discs (part Q) as shown. Form a small loop in the end of a shroud line. Holding loop, gently center loop inside tape disc on the sticky side. Then carefully press tape disc onto its proper place on the top of the parachute. Firmly press the tape disc into place until both tape disc and parachute material are molded around the shroud line loop. Repeat for other shroud line ends and tape discs. Holding the center of the chute, pull the shroud lines tight. Tie a knot in the ends of the shroud lines. Pass the shock cord through the loop in the end of the shroud line knot. At a point about 2" from the free end of the shock cord, tie it around the shroud line loop.

**25**

GLUE BASE INTO NOSE CONE  
USE PLASTIC MODEL CEMENT ONLY

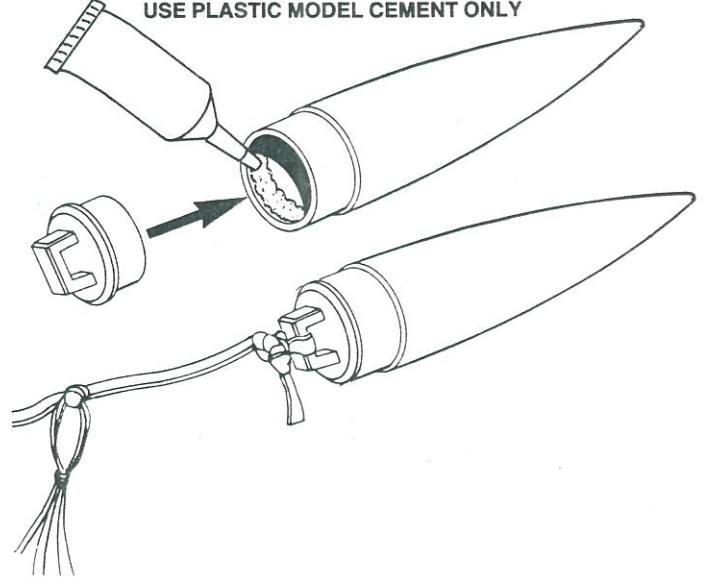

Apply plastic model cement (tube type or liquid) around the inside of the end of the nose cone (part R). Socket the base (part S) in place. NOTE: DO NOT USE WHITE GLUE FOR THIS. Allow cement to dry. Tie the end of the shock cord to the nose cone, tie a triple knot. Roll up the chute and shroud lines and push them, along with the shock cord, down into the body tube. Socket the nose cone into place.

**PAINTING AND DETAILING**

**26**

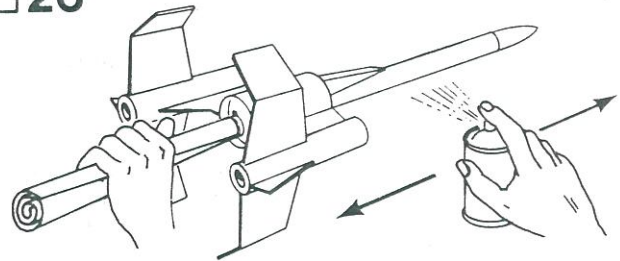

SPRAY SEVERAL LIGHT COATS

Carefully wipe the model with a slightly damp cloth to remove dust and fingerprints. Roll a piece of paper and insert into the rear of the body (for a painting holder). The model may be brush painted, but for the best results, we recommend an aerosol spray can. The model shown on the panel was painted with Pactra "rebel gray". Follow directions printed on the spray can. In order to get complete coverage on the inside of the fins, spray the rear portion from several angles. Allow the paint to dry for several hours before applying decals.

**DECAL PLACEMENT**

**27**

Apply the decals (part T) in the positions shown. (A) Cut only one decal at a time from sheet. (B) Submerge decal in lukewarm water until decal slides on backing paper (usually 15 to 30 seconds). (C) Gently slide decal from backing paper onto model. (D) Move decal into exact position and carefully blot away excess water with a soft cloth. (E) If the decal "sticks" before you have it in position, apply water over the decal with a brush. This will permit the decal to be moved. (F) Smooth out all wrinkles and air bubbles before the decal dries. Refer to the photograph for decal positions.

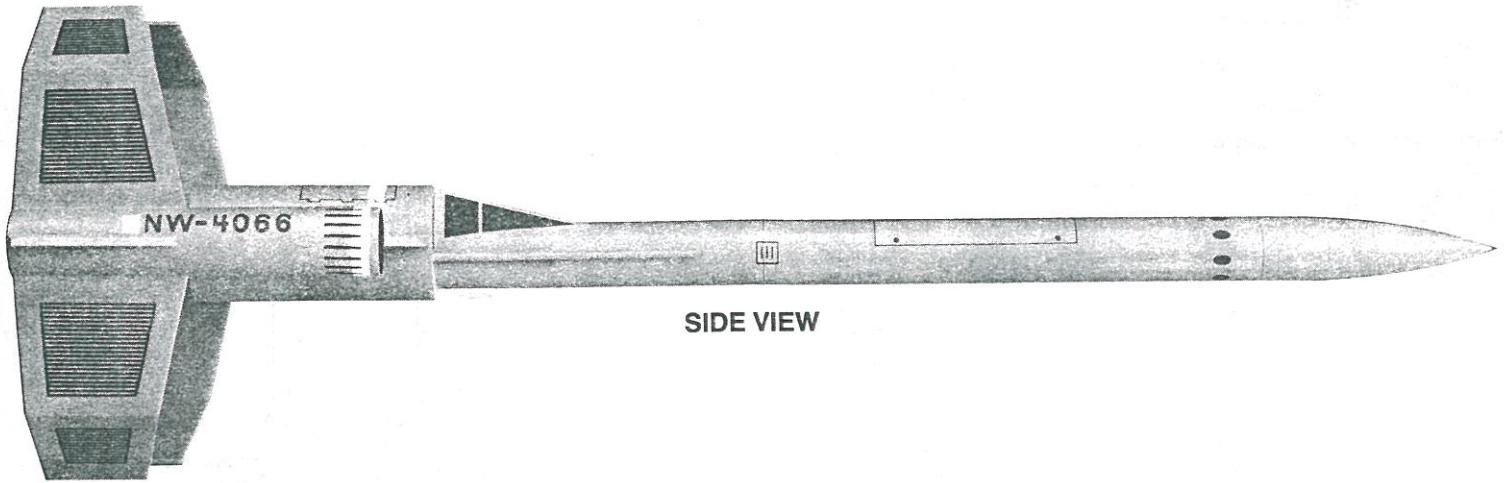

SIDE VIEW

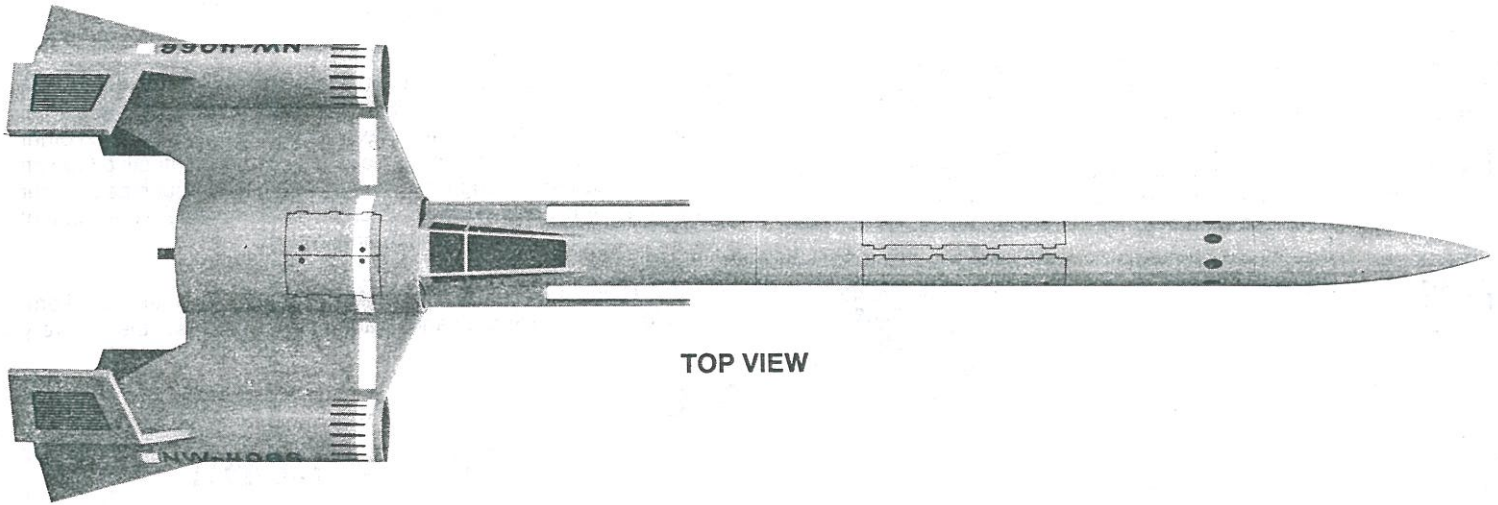

TOP VIEW

## LAUNCHING COMPONENTS

- To launch your rocket you will need the following items:
- An Estes model rocket launching system
  - Flame resistant recovery wadding (Estes Cat. No. 2274)
  - Estes A8-3, B4-4, B6-4, B8-5 or C6-5 model rocket engines.
- Use a B4-4 engine for your first flight.

Be sure to follow the HIAA-NAR\* Model Rocket Safety Code when carrying out your model rocket activities.

\*HIAA—Hobby Industry Association of America  
\*NAR—National Association of Rocketry

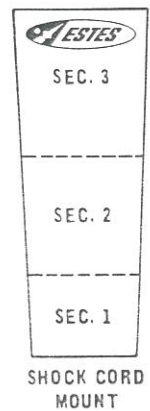
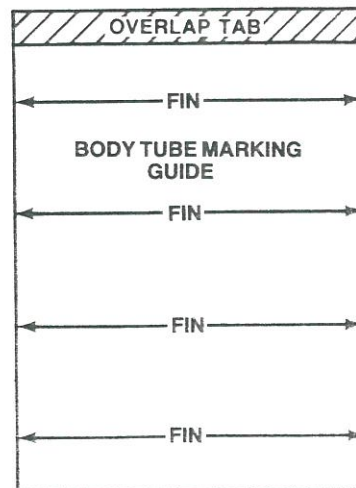
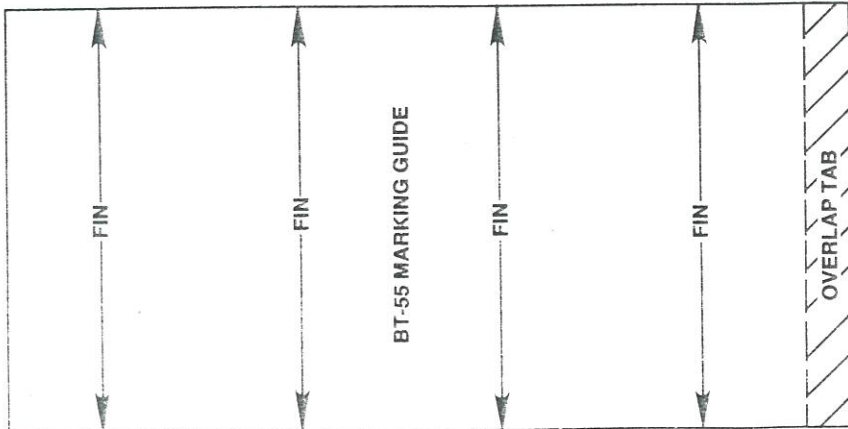

# COUNTDOWN CHECKLIST

## T-13

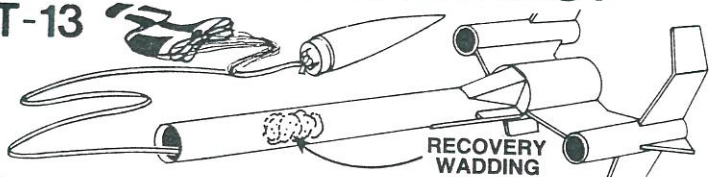

Pack 3 squares of loosely crumpled recovery wadding into the body tube.

## T-12

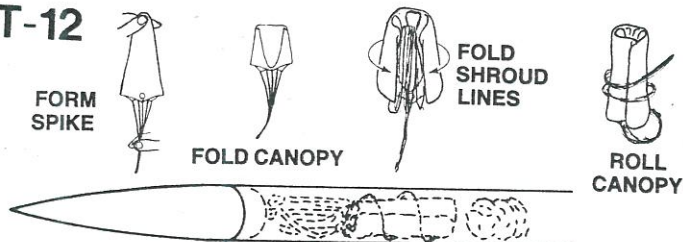

Hold the parachute at its center and pass the other hand down it to form a "spike" shape. Fold this spike in half. Fold shroud lines back along parachute and then back down to lower edge of parachute to reduce length of shroud line "left over". Roll parachute into tube shape to fit easily into body. Any remaining shroud line should be loosely wrapped around parachute. Pack 'chute into the body tube on top of the wadding. Pack the shroud lines and shock cord in on top of the parachute and slip the nose cone into place.

**NOTE: DO NOT** pack parachute until you are actually ready to launch. For maximum parachute reliability, lightly dust the 'chute with ordinary talcum powder before each flight, especially in cold weather.

## T-11

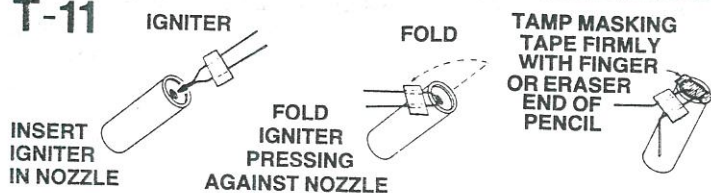

Select an engine and install an igniter as directed in the engine instructions. The engines recommended for use with this rocket are the A8-3, B4-4, B6-4, B8-5, and C6-5 made by Estes. Use a B4-4 engine for your first flight.

## T-10

**ENGINE HOOK MUST LATCH SECURELY**

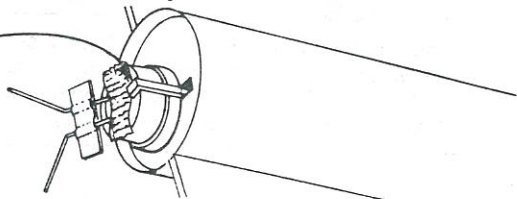

Insert engine into rocket engine mount. Engine hook must latch securely over end of the engine.

## T-9

Disarm the launch panel—REMOVE SAFETY KEY!

## T-8

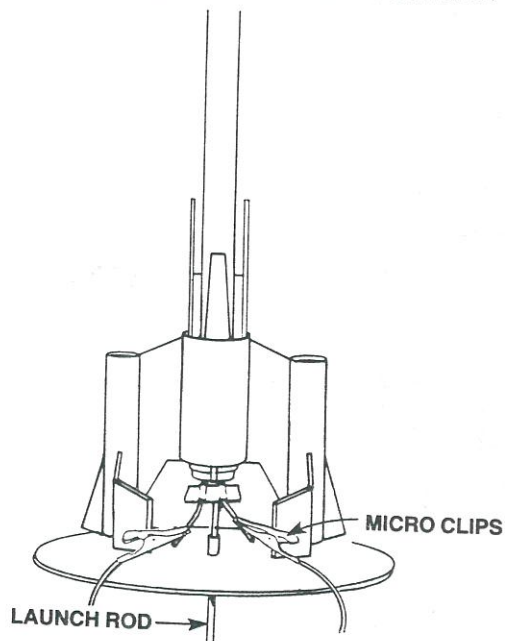

Slide the launch rod through rocket launch lug. Make sure the rocket slides freely on the launch rod. Clean the micro-clips and attach them to the igniter wires. Arrange the clips so they do not touch each other or the metal blast deflector. Attach clips as close to protective tape on igniter as possible. Arrange the clips so they do not touch each other or the blast deflector. Check the micro clips to make sure they cannot become entangled with the fins during launch.

## T-7

Clear the launch area. Alert recovery crew and trackers. Check for low flying aircraft and unauthorized persons in the recovery area.

## T-6

Arm the launch panel—INSERT SAFETY KEY!

# 5-4-3-2-1-LAUNCH!!

Repeat Countdown Checklist for each flight.

## MISFIRE PROCEDURE

Disarm the launch panel. Wait one minute before approaching the rocket on the launch pad. Remove the rocket, clean the igniter residue from the nozzle of the engine, and carefully install a new igniter. Repeat the Countdown Checklist.

Failure of the rocket engine to function properly is nearly always caused by a failure to install the igniter correctly. This failure permits the igniter to heat and burn into two pieces without igniting the engine.