

# T O M A H A W K

SKILL LEVEL 3 - Recommended for Advanced Rocketeers

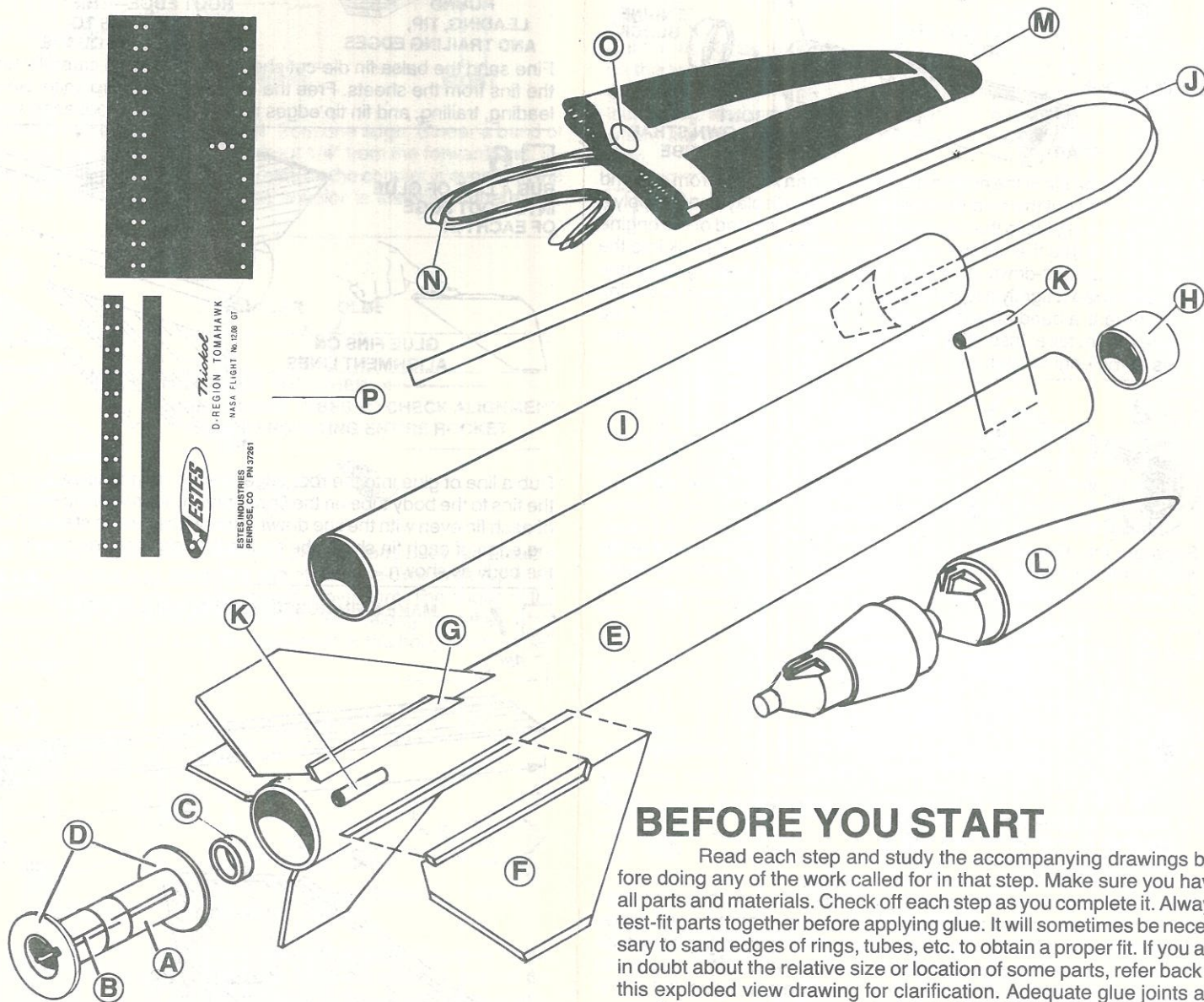

**RECOMMENDED ENGINES**  
D12-5 or D12-7. First Flight: D12-5

## TOOLS AND MATERIALS

In addition to the parts included in this kit you will need: Scissors, pencil, ruler, fine or extra-fine grit sandpaper, sanding sealer, a medium-size modeling paint brush, masking tape, modeling knife with sharp blade, gloss white enamel spray paint, small bottles of black, brown, and red modelers paint, and household white glue or resin glue (Elmer's, Titebond, or similar). Other types of glue are not recommended.



A DAMON COMPANY

**ESTES INDUSTRIES**  
PENROBE, CO 81240 USA

## BEFORE YOU START

Read each step and study the accompanying drawings before doing any of the work called for in that step. Make sure you have all parts and materials. Check off each step as you complete it. Always test-fit parts together before applying glue. It will sometimes be necessary to sand edges of rings, tubes, etc. to obtain a proper fit. If you are in doubt about the relative size or location of some parts, refer back to this exploded view drawing for clarification. Adequate glue joints are very important for a flying model rocket. Follow the instructions carefully in this regard.

## PARTS LIST KIT NO. 1944

A	1 Engine Mount Tube (type BT-50J)	30362
B	1 Engine Hook (type EH-2)	35025
C	1 Engine Block (type AR-2050)	30164
D	1 Adapter Ring Set (type RA-5060)	30132
E	1 Body Tube 18" (type BT-60)	30396
F	2 Die-Cut Balsa Sheet (type BF-1944)	32644
G	3 Balsa Strip (type BFS-30LA)	32112
H	1 Tube Coupler (type JT-60C)	30266
I	1 Body Tube 12 1/2" (type BT-60DS)	30407
J	1 Shock Cord (type SC-1)	85730
K	1 Launch Lug (type LL-12)	38166
L	1 Nose Cone (type PNC-60NA)	72057
M	1 18" Parachute (type PK-18A)	85566
N	1 Shroud Line (type SLT-108)	38239
O	1 Tape Disc Strip (type TD-3F)	38406
P	1 Decal Sheet (type KD-1944)	37261

# ASSEMBLY INSTRUCTIONS

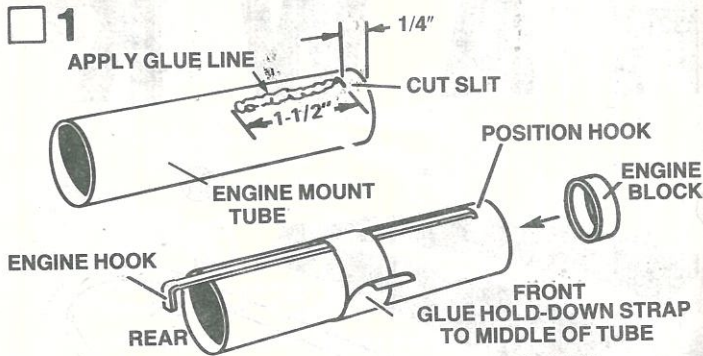

Cut a 1/8" wide slit in the engine mount tube (part A), 1/4" from one end as shown. Cut out the hold-down strap from the display panel. Apply a 1 1/2" long line of glue to the tube as shown. Push one end of the engine hook (part B) into the slit and press the main part of the hook into the glue. Cut out hold-down strap from back of panel. Apply glue to one side, and wrap it tightly around the middle of the tube over the engine hook. Smear a band of glue around the inside of the front end of the engine mount tube. Insert the engine block (part C) and push in until it stops at the engine hook.

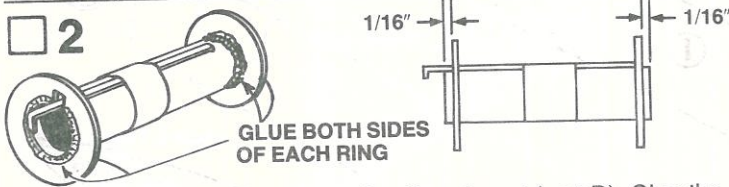

Separate the adapter rings from the die-cut card (part D). Glue the rings to the engine mount tube as illustrated. The notched ring should be placed over the engine hook. Let this assembly dry completely.

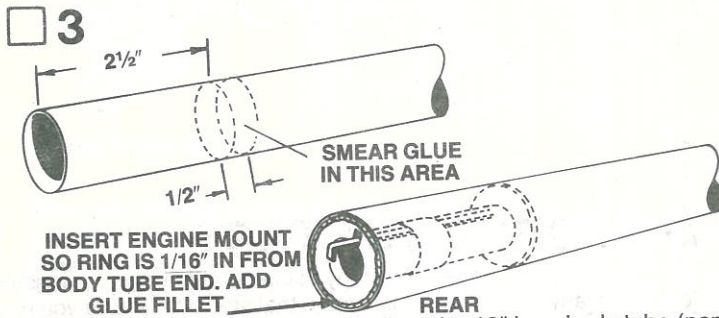

Test fit the engine mount assembly into the 18" long body tube (part E). If necessary, sand the edges of the rings until the unit slides smoothly in the tube. Smear glue around the inside of the body tube about 2 1/2" from one end. Immediately slide the engine mount into place, unnotched ring first, so the end of the engine mount is 1/16" in from the rear of the body tube. Do not pause during this operation, or the glue may stick with the mount in the wrong position. Add extra glue as shown after installation.

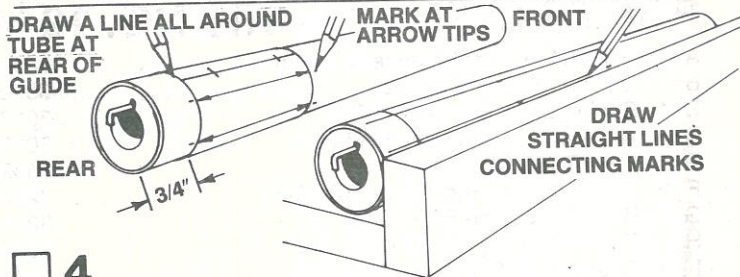

Cut out the body tube marking guide from the display panel. Wrap it around the body tube end which has the engine mount, 3/4" from the rear of the tube. Mark the tube at each arrow point. Draw a line completely around the tube at the rear of the guide as shown. Remove the guide and draw a straight line connecting each matching front and rear marks. (Use a ruler or other straight edge when drawing straight lines.) Extend the launch lug line the length of the tube.

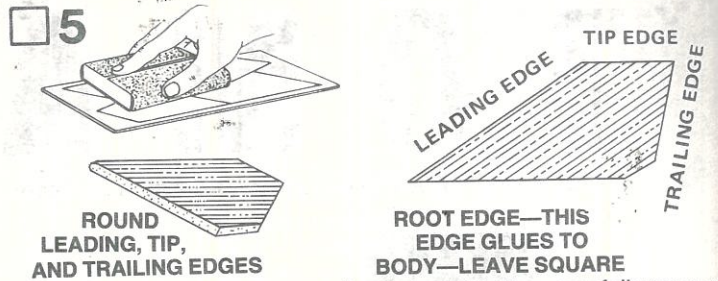

Fine sand the balsa fin die-cut sheets (part F), then carefully remove the fins from the sheets. Free the edges with a sharp knife. Sand the leading, trailing, and fin tip edges round. Sand the root edge square.

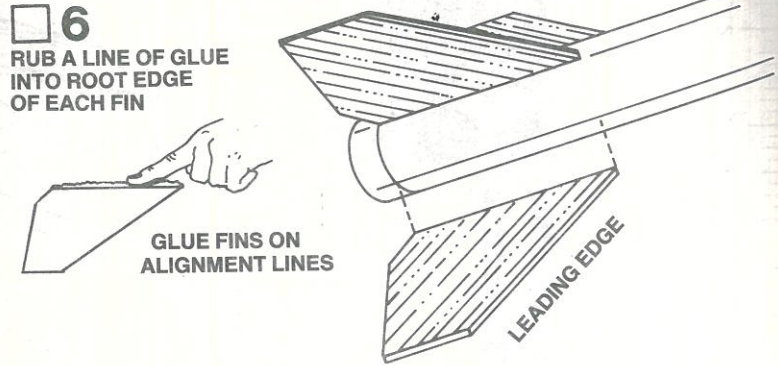

Rub a line of glue into the root edge of each fin and allow to dry. Glue the fins to the body tube on the fin alignment lines with the trailing edge of each fin even with the line drawn around the tube in step 4. The trailing edge of each fin should be on the 3/4" spacing line drawn around the body as shown.

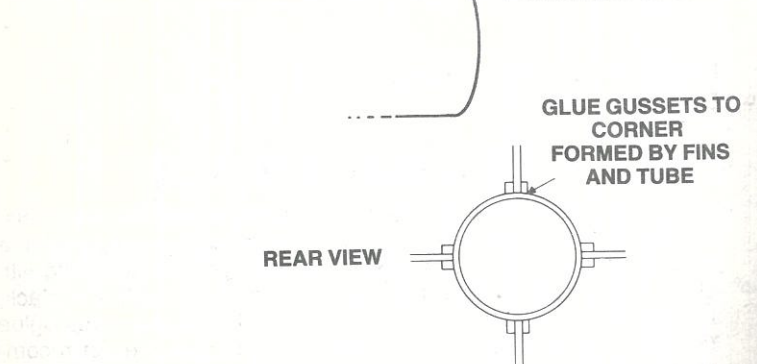
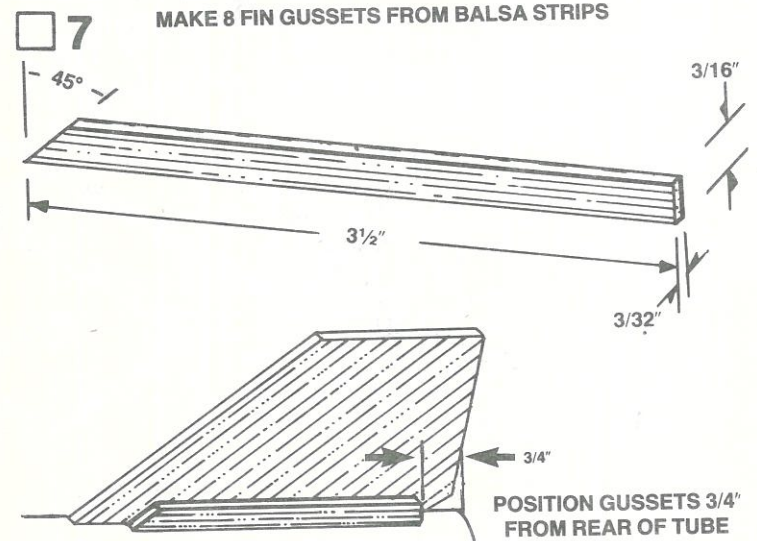

Cut 8 fin gussets from the 3 balsa strips (part G). Lightly sand all surfaces avoiding rounding any of the edges. Glue one gusset to each side of each fin where they touch the body tube. Use the illustrations as a guide for proper positioning.

8

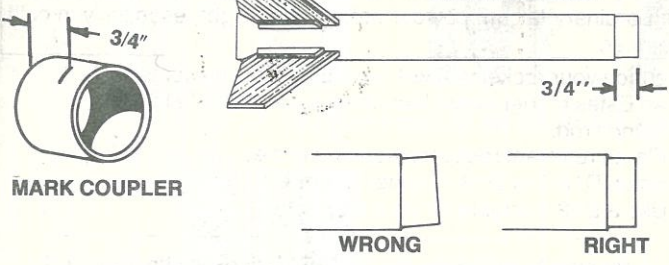

Mark the tube coupler (part H), 3/4" from one edge. Smear a band of glue inside the finned body tube about 1/4" from the forward end. Insert the coupler and push until the mark on the coupler is even with the end of the tube. Be sure the tube coupler is installed squarely as shown.

9

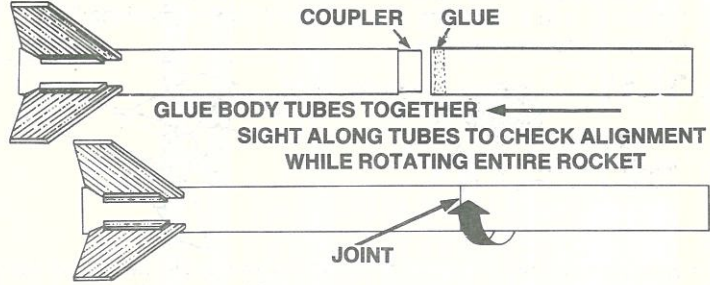

Smear a band of glue inside one end of 12 1/2" long body tube (part I) about 1/4" from the end. Slide this end of the tube over the coupler attached to the finned tube in one smooth movement. The edges of the two body tubes should touch all around. Sight along the tubes while rotating the rocket to be sure the alignment of the body tubes is perfectly straight.

10

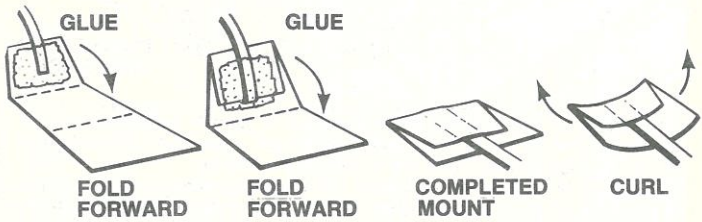

Cut out the shock cord mount from the display panel. Crease it on the dotted lines by folding. Spread glue on the first section (1) and lay the end of the shock cord (part J) into the glue. Fold over and apply glue to the back of the first section and the exposed part of Section (2). Lay the shock cord as shown and fold over again. Clamp the unit together with your fingers until the glue sets.

11

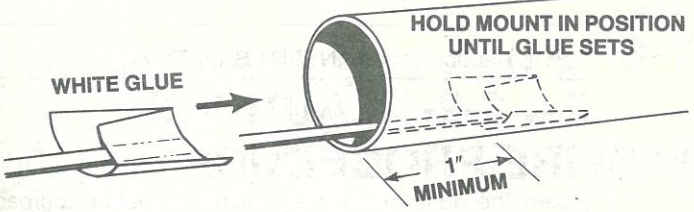

Smear glue over the back side of the shock cord mount as shown. Hold the mount so its narrow end enters the tube first and press it into place in the front of the body tube. Make sure the front of the mount is at least 1" or more from the tube end to allow for the nose cone. Hold the mount in place until the glue sets.

12 CUT LAUNCH LUG INTO TWO 1" LENGTHS

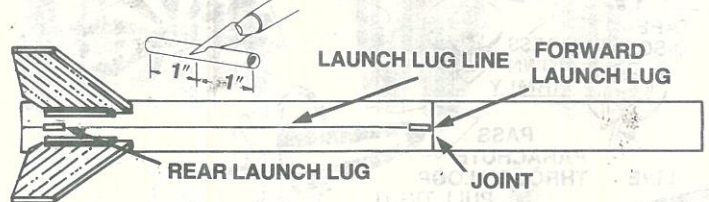

Cut the launch lug (part K) into two 1" lengths. Glue one of these lugs on the launch lug alignment line with its rear edge even with the line drawn around the tube as shown. Glue the remaining lug on the launch lug alignment line with its forward edge even with the joint where the two body tubes meet. Align the lugs straight on the body tube.

13

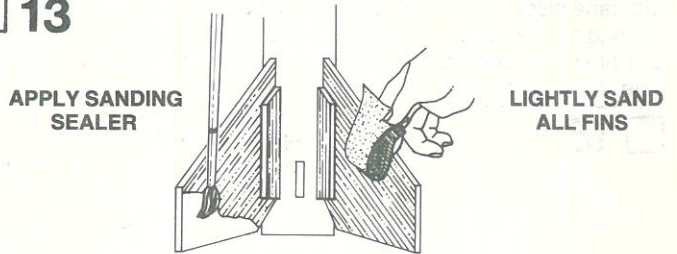

Proper application of sanding sealer makes the rocket look better and reduces drag so that the rocket will fly higher. However, this step is not essential to make a safe, attractive rocket. Apply a coat of sanding sealer to each fin and gusset. When sealer is dry, lightly sand all the sealed surfaces. Repeat sealing and sanding process until balsa grain is filled and smooth.

14

SPRAY PAINT FOR BEST RESULTS

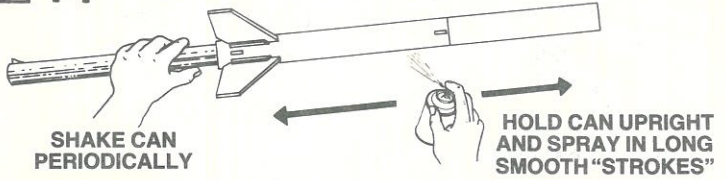

After the last coat of sanding sealer, sand again, then dust off the model. Paint the entire model gloss white.

15

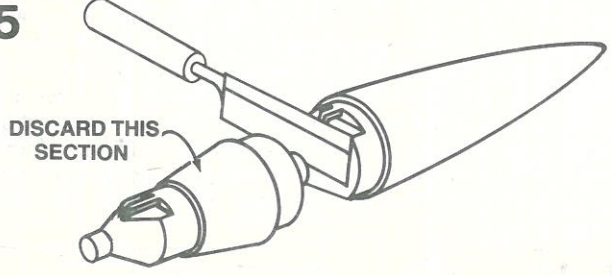

Separate the nose cone/adaptor (part L) using either a sharp modeling knife or modeler's saw. Use the grooves molded into the part as cutting guide. Discard the adaptor section, as it is not used.

16

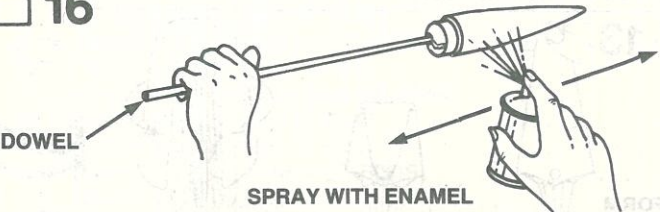

Spray paint the nose cone with several light coats of white paint. The nose cone can be supported by a dowel or stick inserted in the center opening in the nose cone while being painted and drying. A layer of masking tape around nose cone shoulder works well to protect the nose cone shoulder from "overspray" while painting.

**17**

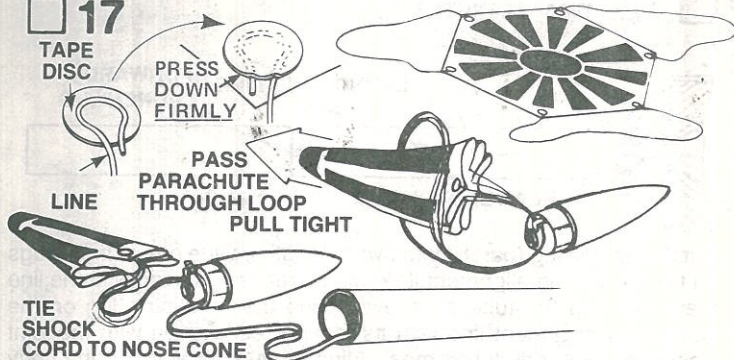

Cut out the parachute (part M) on its edge lines. Cut three 36" lengths of shroud line (part N). Attach the line ends to the top of the parachute with tape discs (part O) as shown. Pass the shroud line loops through the ring on the nose cone. Pass the parachute through the loop ends and draw the lines tight against the ring. Set the knot with a drop of glue. Tie the free end of the shock cord to the nose cone.

**18**

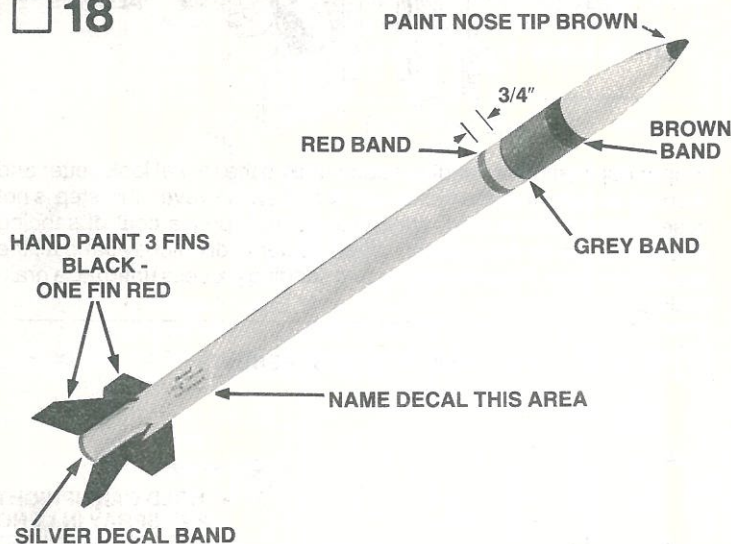

When all paint is dry, apply the decals (part P) in the positions shown. (A) Cut only one decal at a time from sheet. (B) Submerge decal in lukewarm water until decal slides on backing paper (usually 15 to 30 seconds). (C) Gently slide decal from backing paper onto model. (D) Move decal into exact position and carefully blot away excess water with a soft cloth. (E) If the decal "sticks" before you have it in position apply water over the decal with a brush. This will permit the decal to be moved. (F) Smooth out all wrinkles and air bubbles before the decal dries. We recommend that the completed model be sprayed with Teslor's "Dull-Cote". This is a flat clear spray paint that protects the model's finish.

**T-14**



Crumple and insert 5 or 6 squares of wadding into the forward end of the body tube.

**T-13**

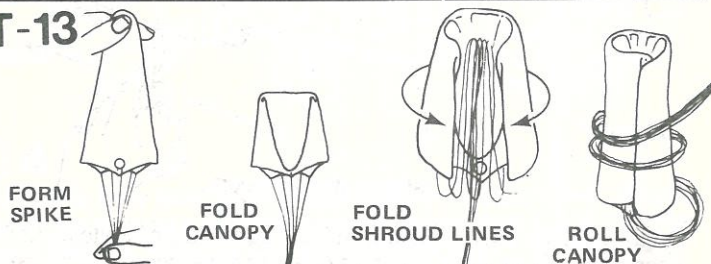

Fold the parachute into a triangular shape. Fold 'chute tightly as shown and wrap shroud lines around it. If 'chute is too large, unroll it and repack until it slides easily into rocket. A fit that is too tight may prevent parachute from ejecting properly.

**NOTE: DO NOT** pack parachute until you are actually ready to launch. For maximum parachute reliability, lightly dust the 'chute with ordinary talcum powder before each flight, especially in cold weather.

To launch your rocket you will need the following items:

- An Estes model rocket launching system with 3/16" dia. launch rod.
  - Flame resistant recovery wadding (Estes Cat. No. 2274)
  - Estes D12-5 or D12-7 model rocket engines.
- Use a D12-5 engine for your first flight.

Be sure to follow the HIAA-NAR\* Model Rocket Safety Code when carrying out your model rocket activities.  
 \*HIAA—Hobby Industry Association of America  
 \*NAR—National Association of Rocketry

**T-12**

Pack cord neatly into rocket, then slide nose cone into place. Nose cone should separate easily from rocket body tube, but should not be extremely loose. If it is too tight, sand inside of body tube end and shoulder of nose cone with extra fine sandpaper. If nose cone is too loose, add a wrapping of transparent tape or masking tape to the shoulder of the nose cone.

**T-11**



Select an engine and install an igniter as directed in the engine instructions. Engines recommended for use with this model rocket are the D12-5 or D12-7 made by Estes.

**T-10**

Insert engine into rocket. Engine hook must latch securely over end of engine.

**CUT COAT HANGERS AND BEND AS SHOWN**

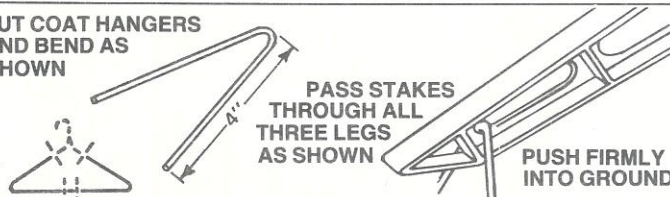

Due to the rocket's length, additional launch pad stability is required for safety. Weigh down or secure your pad with bricks or coat hanger stakes using the following procedure.

Cut three hold-down stakes from coat hangers as shown. Adjust the launch pad on level ground. Pass the stake hooks through the launch pad legs, then push the stakes firmly into the ground. Check to be sure the launch pad is held down securely before proceeding.

**T-9**

Disarm the launch panel—REMOVE SAFETY KEY!

**T-8**

Place rocket on launch pad, making sure rocket slides freely on launch rod. Clean the micro-clips and attach them to the igniter.

**T-7**

Clear the launch area. Alert recovery crew and trackers. Check for low flying aircraft and unauthorized persons in the recovery area.

**T-6**

Arm the launch panel—INSERT SAFETY KEY!

**5-4-3-2-1-LAUNCH!!**

**MISFIRE PROCEDURE**

Disarm the launch panel. Wait one minute before approaching the rocket on the launch pad. Remove the rocket, clean the igniter residue from the nozzle of the engine, and carefully install a new igniter. Repeat the Countdown Checklist.

Failure of the rocket engine to function properly is nearly always caused by a failure to install the igniter correctly. This failure permits the igniter to heat and burn into two pieces without igniting the engine.