

INCHES



# STARHAWK

SKILL LEVEL 3 - Recommended for Advanced Rocketeers

## RECOMMENDED ENGINES

A8-3 (First Flight), B4-4, B6-4, B8-5, C6-5 or C6-7



ESTES INDUSTRIES  
PENROSE, CO 81240 USA

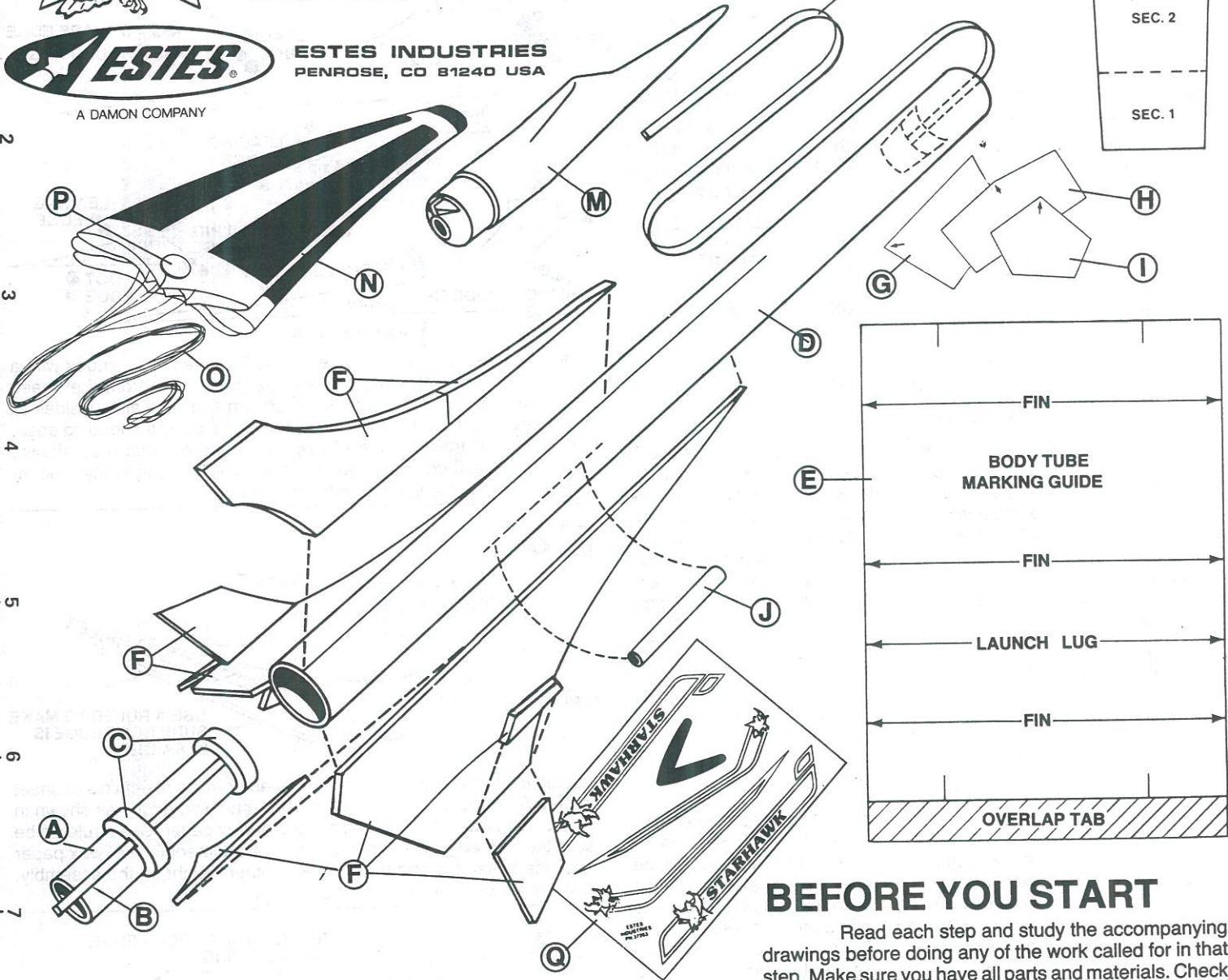
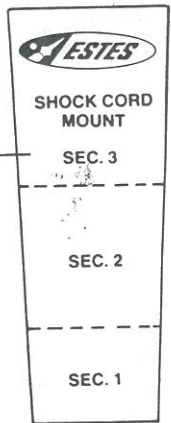

## PARTS LIST

## KIT 1946

A	1	Engine Mount Tube (BT-20J)	30326
B	1	Engine Hook (EH-2)	35025
C	2	Adapter Rings (AR-2050)	30164
D	1	Body Tube (BT-50L)	30366
E	1	Body Tube Marking Guide	on page 1
F	1	Balsa Die-Cut Fins (BF-1946)	32646
G	1	Ventral Fin Alignment Guide	on panel back
H	1	Tip Fin Alignment Guide #1	on panel back
I	1	Tip Fin Alignment Guide #2	on panel back
J	1	Launch Lug (LL-2A)	38175
K	1	Shock Cord Mount	on page 1
L	1	Shock Cord (SC-1)	85730
M	1	Nose Cone (PNC-50SP)	71001
N	1	Parachute (PK-12A)	85564
O	1	Shroud Line (SLT-72)	38237
P	1	Tape Discs Set (TD-3F)	38406
Q	1	Decal (KD-1946)	37263

## BEFORE YOU START

Read each step and study the accompanying drawings before doing any of the work called for in that step. Make sure you have all parts and materials. Check off each step as you complete it. Always test-fit parts together before applying glue. It will sometimes be necessary to sand edges of rings, tubes, etc. to obtain proper fit. If you are in doubt about the relative size or location of some parts, refer back to this exploded view drawing for clarification. Adequate glue joints are very important for a flying model rocket. Follow the instructions carefully in this regard.

## TOOLS AND MATERIALS

In addition to the parts included in this kit you will need: Scissors, household white glue (Elmer's, Titebond, or similar), pencil, ruler, fine or extra-fine grit sandpaper, sanding sealer, a medium-size modeling paint brush, modeling knife with sharp blade. Krylon brand "True Blue" spray enamel, wax paper, and Gloss-Cote spray.

# ASSEMBLY INSTRUCTIONS

1

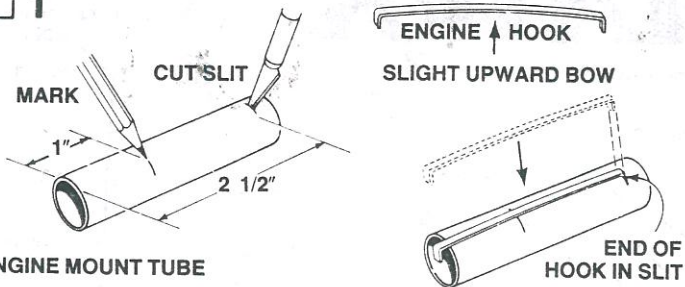

## ENGINE MOUNT TUBE

Mark the engine mount tube (part A) at 1" and 2 1/2" from one end. Cut a 1/8" long slit at the 2 1/2" mark. Gently bend the engine hook (part B) so that it bows upward very slightly in the middle. (Study the drawing—Don't bend the wrong way.) Insert one end of the engine hook into the slit in the tube.

2

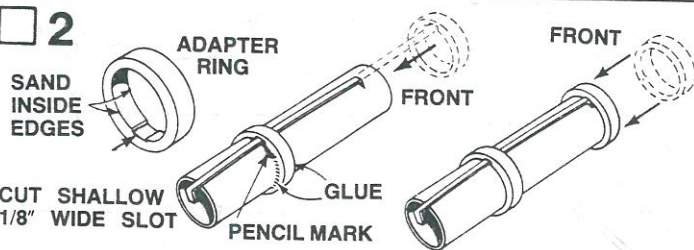

CUT SHALLOW 1/8" WIDE SLOT

Sand the inside edges of the two adapter rings (part C) to remove burrs. The rings should slide easily onto the engine mount tube. Cut a very shallow 1/8" wide slot inside one adapter ring so it will fit over the engine hook. Slip the ring onto the front end of the engine mount tube and slide it down to the 1" mark. Make sure the engine hook runs straight down the tube, then apply glue to both sides of this adapter ring. Apply glue around the front end of the engine mount tube and slide the remaining adapter ring into place (front of ring even with the end of the tube).

3

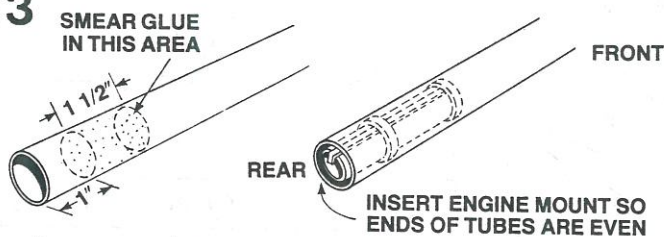

The engine mount unit will be pushed into place so that the rear of the engine mount unit (end with engine hook projecting) is even with the rear of the body tube (part D). Test-fit the engine mount unit several times by smoothly inserting and removing it. Sand if necessary to assure a smooth fit. Once this can be smoothly and easily done, remove the engine mount unit. Apply a ring of glue around the inside of the rear of the main body tube about 2" to 2 1/2" from the end of the tube. Make certain that the engine hook is to the rear and insert the engine mount unit with one smooth motion. Do not pause, or the glue may "lock" with the engine mount unit in the wrong position.

4

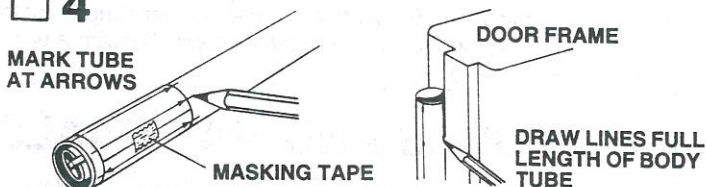

Cut out the body tube marking guide found on page 1 of instructions (part E) and tape it around the body tube. Place the tube marking guide so that the engine hook lines up with the launch lug line (arrow point). Mark the body tube at each of the arrow points. Draw straight lines connecting each pair of marks. A door frame inside edge can be used as a guide as shown. Extend the lines the full length of the tube. Label each line with name of part which goes on it.

5

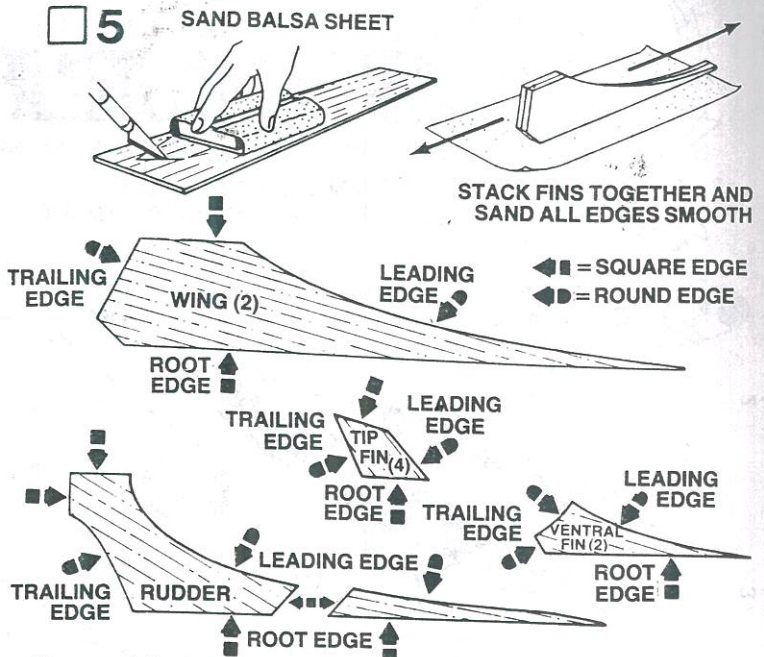

Fine-sand the balsa die-cut sheet (part F). Free the fin edges with a sharp knife, then carefully remove the die-cut fins from the sheet. Stack each group of fins together as shown and sand all four sides as illustrated. Lightly sand both sides of each fin. Sand the leading edge, tip edge, and trailing edge of each fin round or square as shown. Leave the root (body) edge sanded "flat". The root edge may be identified by careful comparison with the drawings.

6

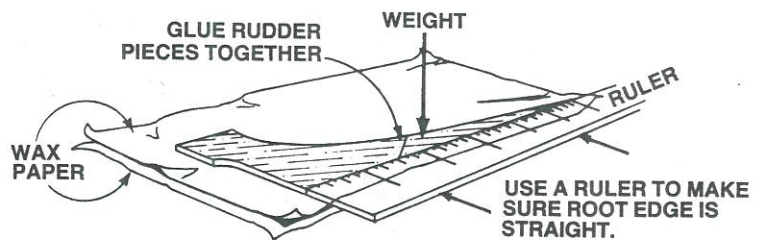

Locate the two pieces of the rudder taken from the die-cut balsa sheet in step 5. Place glue on one of the two matching edges as shown in step 5. Join the two pieces on a piece of wax paper. Use a ruler to be sure the root edge is straight. Now place another piece of wax paper over the assembly and put a book or other weight on the assembly. Allow the rudder to dry completely.

7

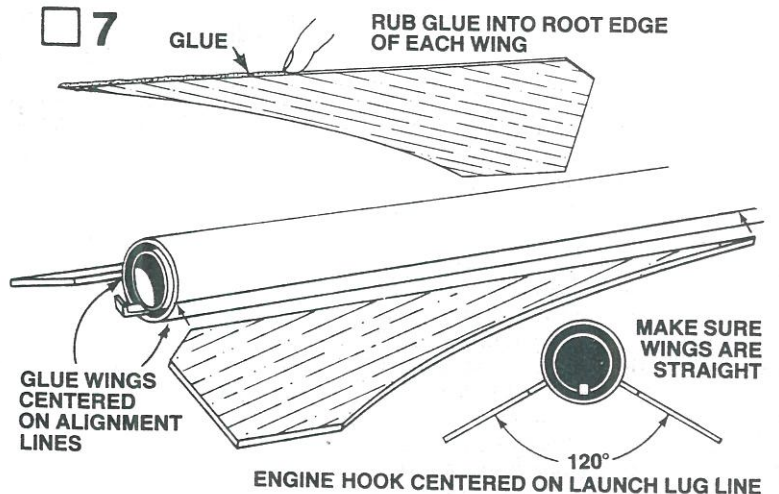

Rub glue into the root edge of each wing and allow to dry. Apply glue to the wings again and position wings on the alignment lines in positions shown. Adjust the wings so they project straight away from the body tube. DO NOT set the rocket on its wings while the glue is wet.

8

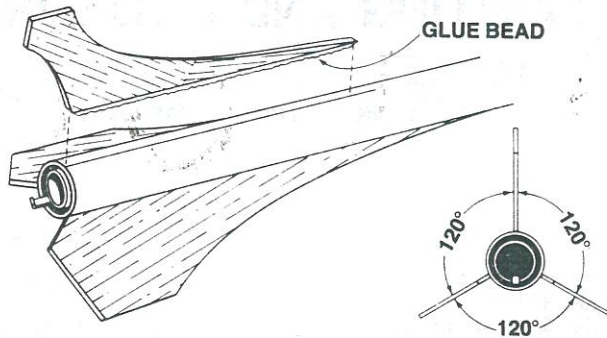

Rub glue into the root edge of the completed rudder assembly from step #6 and allow to dry. Apply glue to the rudder again and position it on the alignment line opposite the engine hook as shown. Adjust the rudder so it projects straight away from the body tube and is equally spaced between the wings. Do not set the rocket on its wings or rudder while the glue dries.

9

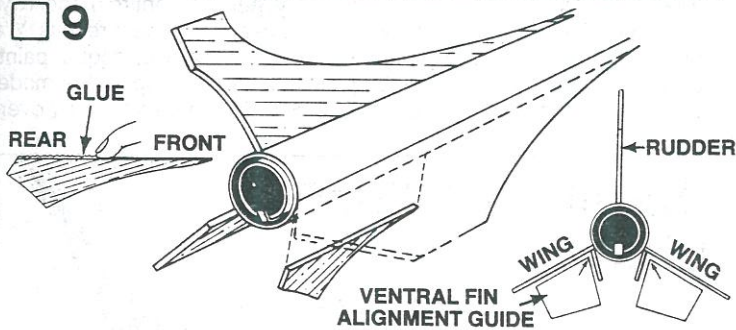

Cut the ventral fin alignment guide (part G) from the back of the kit panel. Repeat the gluing procedure for the two ventral fins and glue them to the undersides of the wings even with the rear end of the body tube, and along the wing/body tube joints. Use the ventral fin alignment guide to get these fins at the proper angle to the wing bottoms. Allow the ventral fins to dry completely.

10

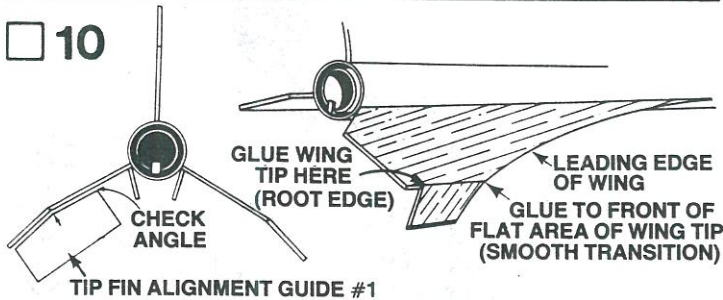

Cut out the tip fin alignment guide #1 (part H) found on the panel back. Lightly sand the root edge of two of the tip fins until they match the angle of the tip fin alignment guide #1. See above illustration. Glue the tip fins to the wing tips so their leading edges are at the very front of the flat area of the wing tips. They should form a smooth transition with the curved leading edge of the wings. Check the angles of the tip fins again and set the assembly aside to dry.

11

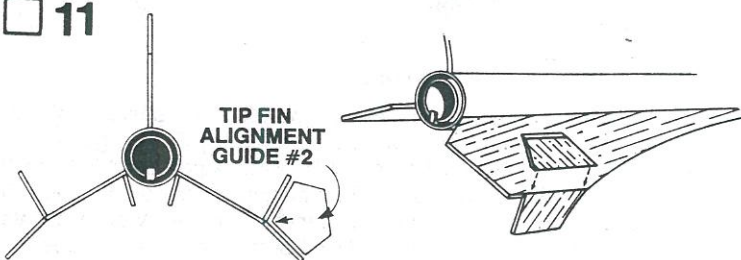

Cut out the tip fin alignment guide #2 (part I) found on the panel back. Glue the remaining two tip fins on the top of the wings so they are even with the tip fins installed in step #10. See above illustration for correct location. Use the tip fin alignment guide #2 to check for proper angles. Allow these fins to dry completely.

12

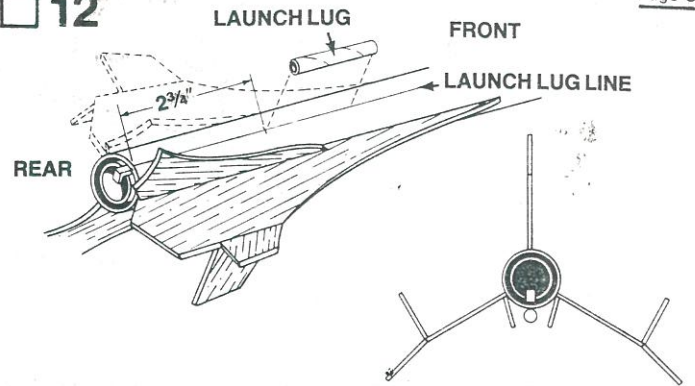

Turn model over and measure 2 3/4" from the rear of the model up the launch lug line and make a mark. Glue the rear end of the launch lug (part J) to the launch lug line at the 2 3/4" mark as shown in the illustration. Be sure the launch lug is centered on the launch lug line.

13

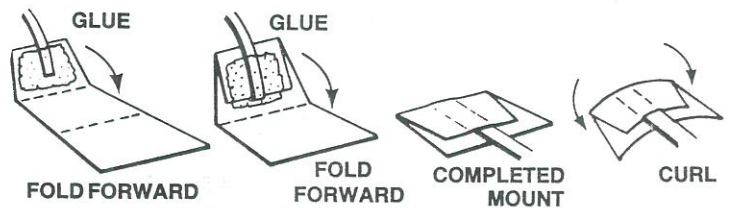

Cut out the shock cord mount (part K) found on page 1 of instructions. Fold on dotted lines, then unfold and apply glue to Section 1. Lay the end of the shock cord (part L) into the glue. Fold over and apply glue to the back of Section 1 and the exposed portion of Section 2. Fold again to complete mount. Curl the edges of the mount down so it will match the contour of the body tube and hold with your fingers until the glue sets.

14

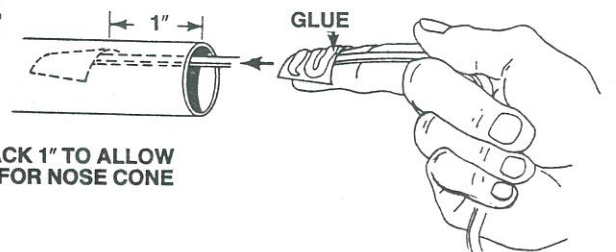

Apply glue to the back of the shock cord mount. With the shock cord mount positioned on the end of your finger, gently position mount down into front of body tube far enough from the front edge of the tube to allow for the nose cone to fit into place. Press shock cord mount firmly into position. To insure a good bond, smear a film of glue over the mount and surrounding area in the body tube.

15

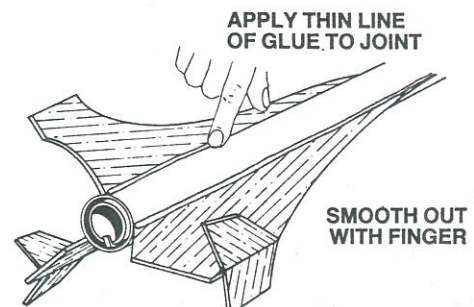

When the glue on the fin joints has dried, apply a glue reinforcement to each fin/body tube joint. Holding the model level, apply a line of glue to both sides of each balsa joint and on both sides of the launch lug. Smooth out the glue with your finger. IMPORTANT—Keep the model level until the glue dries.

16

LIGHTLY SAND ALL BALSA SURFACES BETWEEN SEALER COATS

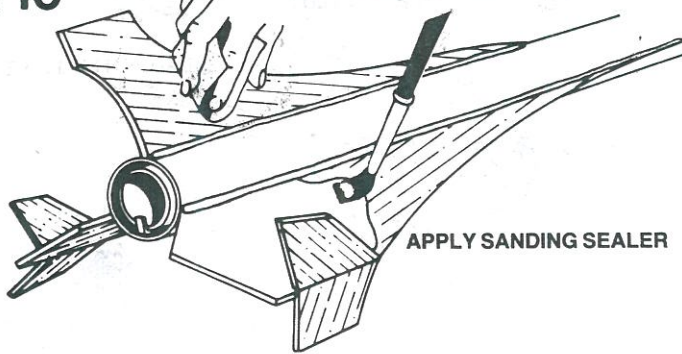

APPLY SANDING SEALER

Proper application of sanding sealer makes the rocket look better and reduces drag so that the rocket will fly higher. However, this step is not essential to make a safe, attractive rocket. Apply a coat of sanding sealer to each wing and the rudder. When sealer is dry, lightly sand all the sealed surfaces. Repeat sealing and sanding process until balsa grain no longer shows.

17

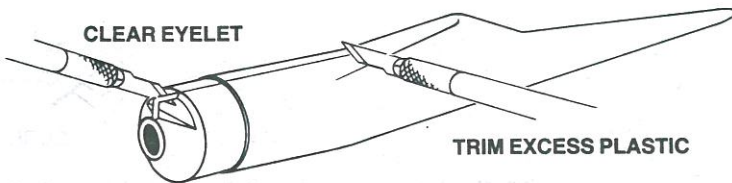

CLEAR EYELET

TRIM EXCESS PLASTIC

Trim or sand any excess plastic from around the sides of the nose cone (part M). Use a sharp knife to remove any excess plastic from the inside of the molded eyelet at the rear of the nose cone. Wash the nose cone with lukewarm soapy water, rinse well, and dry.

18

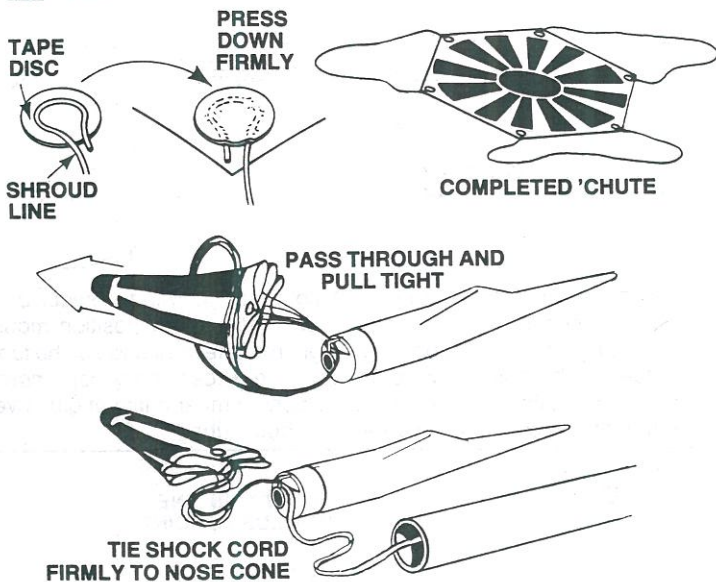

PRESS DOWN FIRMLY

TAPED DISC

SHROUD LINE

COMPLETED CHUTE

PASS THROUGH AND PULL TIGHT

TIE SHOCK CORD FIRMLY TO NOSE CONE

Cut out the parachute (part N) on its edge lines. Cut three lengths of shroud line (part O). Attach line ends to the top of the parachute with tape discs (part P) as shown. Form a small loop in the end of a shroud line. Holding loop, gently center loop inside tape disc on the sticky side. Then carefully press tape disc onto its proper place on the top of the parachute. Firmly press the tape disc into place until both tape disc and parachute material are molded around the shroud line loop. Repeat for other shroud line ends and tape discs. Pass the shroud line loops through the loop on the nose cone. Pass the parachute through the loop ends and pull the lines tight against the nose cone. Tie the free end of the shock cord firmly to the nose cone loop. A square knot or strong double knot should be used.

# PAINING AND DETAILING

19

SHAKE CAN BEFORE SPRAYING

USE ROLLED PAPER FOR ROCKET HOLDER

HOLD CAN STRAIGHT UP AND SPRAY IN LONG, SMOOTH "STROKES".



FIRST COATS ARE LIGHT, DRY MIST COATS. SHAKE CAN PERIODICALLY. TO OBTAIN GLOSS, FINAL COAT SHOULD BE APPLIED SLIGHTLY HEAVIER.

After the sanding sealer is completely dry, paint the entire model Krylon "True Blue". Follow instructions on spray can for best results. We recommend spray enamel. Do not paint the model with lacquer paint. Lacquer will mar the finish of the plastic nose cone. Spray the model with several light coats of paint to avoid "runs". Let this coat dry overnight.

# DECAL PLACEMENT

20

CENTER ON CANOPY

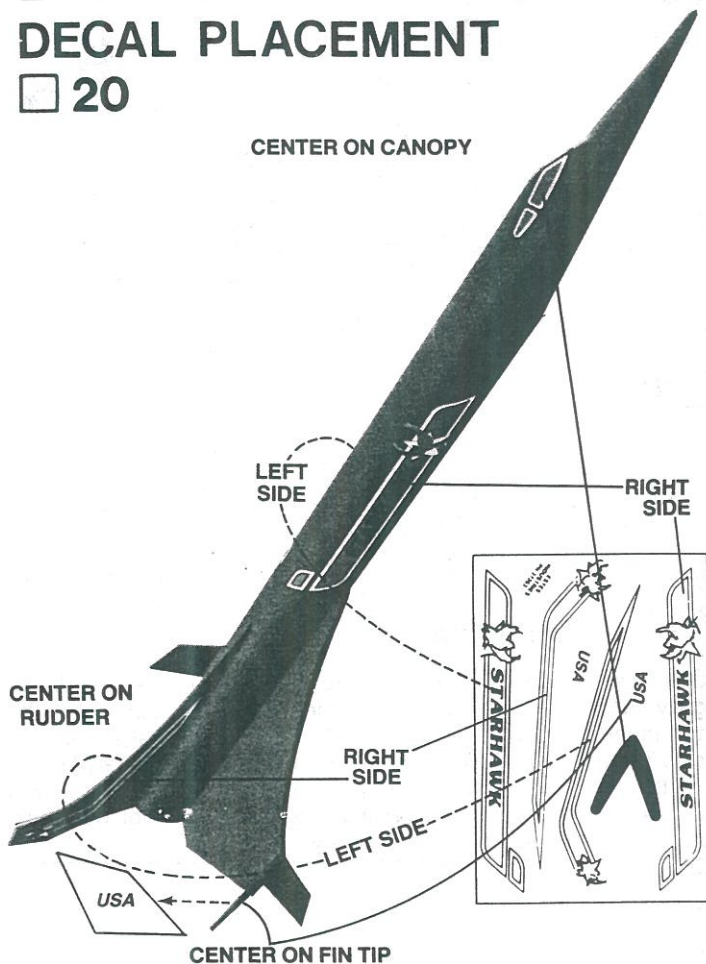

LEFT SIDE

RIGHT SIDE

CENTER ON RUDDER

RIGHT SIDE

CENTER ON FIN TIP

When all paint is dry, apply the decals (part Q) in the positions shown. (A) Cut only one decal at a time from sheet. (B) Submerge decal in lukewarm water until decal slides on backing paper (usually 15 to 30 seconds). (C) Gently slide decal from backing paper onto model. (D) Move decal into exact position and carefully blot away excess water with a soft cloth. (E) If the decal "sticks" before you have it in position, apply water over the decal with a brush. This will permit the decal to be moved. (F) Smooth out all wrinkles and air bubbles before the decal dries. We recommend that the completed model be sprayed with Teslor's "Gloss-Cote". This is a clear spray paint that protects the model's finish.

# LAUNCHING COMPONENTS

To launch your rocket you will need the following items:

- An Estes model rocket launching system
- Flame resistant recovery wadding (Estes Cat. No. 2274)
- Estes A8-3, B4-4, B6-4, B8-5, C6-5 or C6-7 model rocket engines.

Use an A8-3 engine for your first flight.

## COUNTDOWN CHECKLIST

### T-13

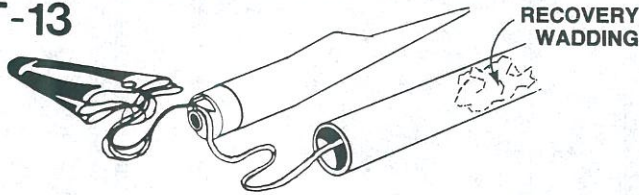

Slide 4 or 5 squares of loosely crumpled recovery wadding into the body tube. Usually this will fill the body tube for a distance equal to about 1-1/2 times its diameter.

### T-12

FORM SPIKE

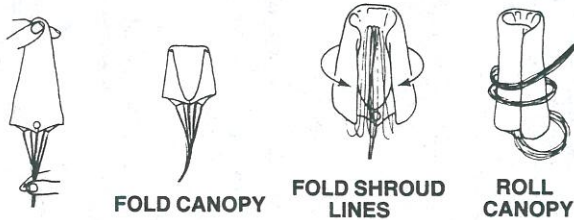

Hold the parachute at its center and pass the other hand down it to form a "spike" shape. Fold this spike in half. Fold shroud lines back along parachute and then back down to lower edge of parachute to reduce length of shroud line "left over". Roll parachute into tube shape to fit easily into body. Any remaining shroud line should be loosely

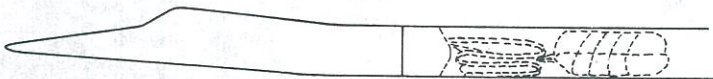

wrapped around parachute. Slide 'chute into the body tube on top of the wadding. Slide the shroud lines and shock cord in on top of the parachute and slip the nose cone into place.

**NOTE:** Nose cone should separate easily from rocket body tube, but should not be extremely loose. If fit is too tight, sand inside of body tube and shoulder of nose cone with fine sandpaper. If fit is too loose, add a wrapping of masking tape to the shoulder of the nose cone.

**NOTE:** DO NOT pack parachute until you are actually ready to launch. For maximum parachute reliability, lightly dust the 'chute with ordinary talcum powder before each flight, especially in cold weather.

### T-11

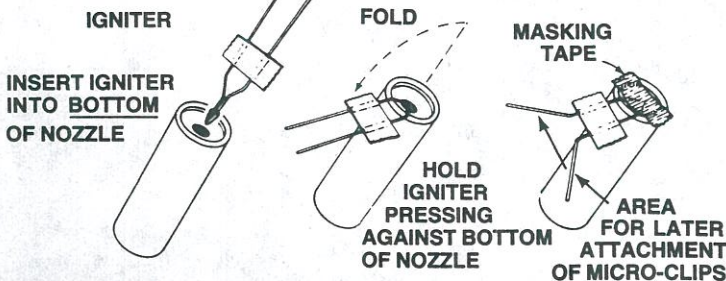

Select an engine and install an igniter as directed in the engine instructions. The engines recommended for use with this rocket are the A8-3, B4-4, B6-4, B8-5, C6-5, and C6-7 made by Estes.

Use an A8-3 engine for your first flight.

### T-10

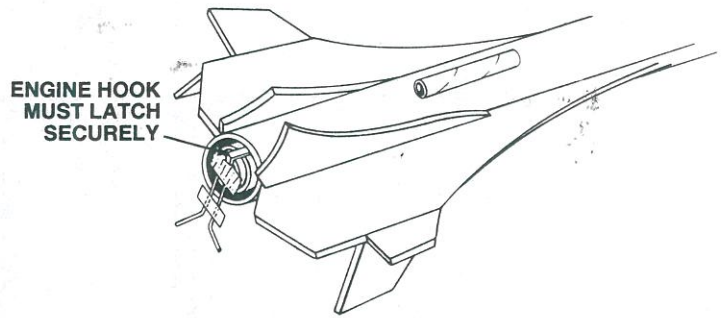

Insert engine into rocket engine mount. Engine hook must latch securely over end of the engine.

### T-9 Disarm the launch panel—REMOVE SAFETY KEY!

### T-8

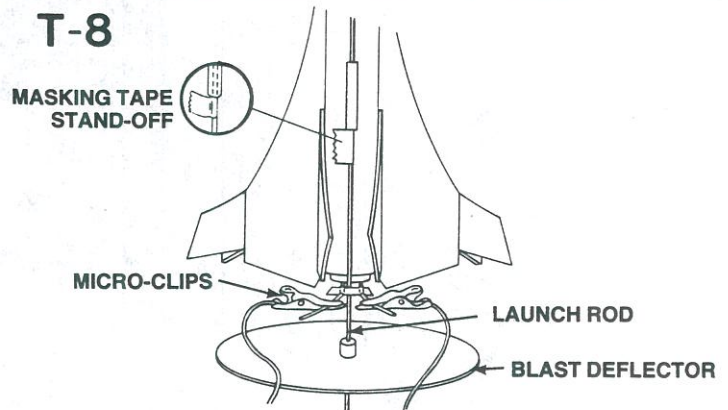

Slide the launch rod through rocket launch lug and place rocket on launch pad. Make sure the rocket slides freely on the launch rod. Clean the micro-clips and attach them to the igniter wires. Arrange the clips so they do not touch each other or the metal blast deflector. Attach clips as close to protective tape on igniter as possible.

**T-7** Clear the launch area. Alert recovery crew and trackers. Check for low flying aircraft and unauthorized persons in the recovery area.

**T-6** Arm the launch panel—INSERT SAFETY KEY!

## 5-4-3-2-1-LAUNCH!!

Repeat Countdown Checklist for each flight.

## MISFIRE PROCEDURE

Disarm the launch panel. Wait one minute before approaching the rocket on the launch pad. Remove the rocket, clean the igniter residue from the nozzle of the engine, and carefully install a new igniter. Repeat the Countdown Checklist.

Failure of the rocket engine to function properly is nearly always caused by a failure to install the igniter correctly. This failure permits the igniter to heat and burn into two pieces without igniting the engine.



A DAMON COMPANY