



A DAMON COMPANY  
 Estes Industries  
 1295 H Street  
 Penrose, CO 81240

# NIKE-APACHE<sup>TM</sup> Flying Model Rocket #1957



A DAMON COMPANY

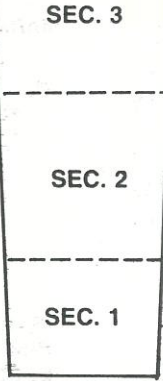
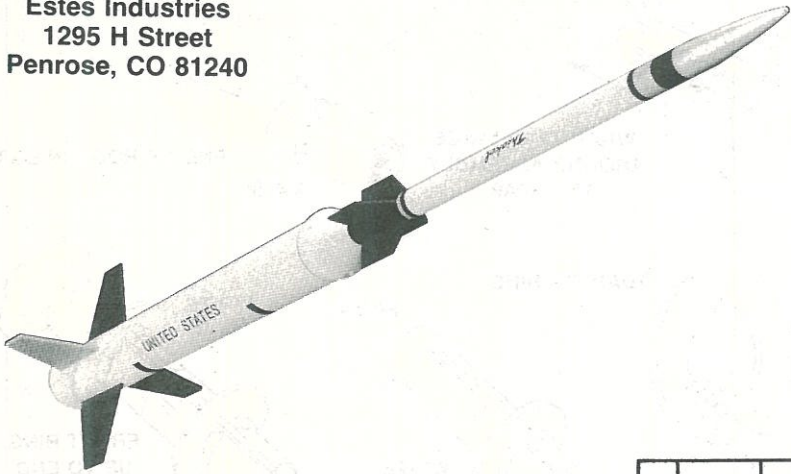

SHOCK CORD MOUNT

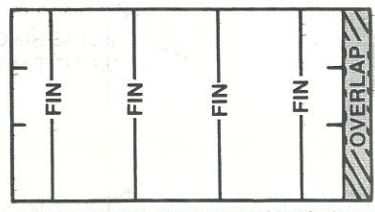

APACHE BODY TUBE MARKING GUIDE

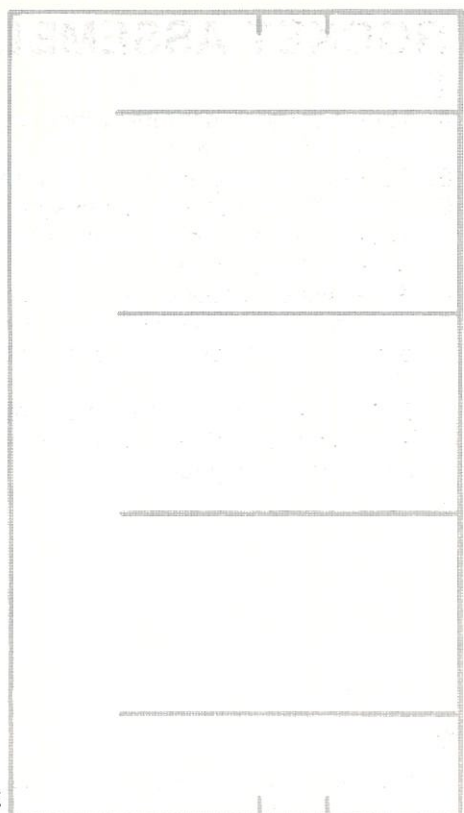

NIKE BODY TUBE WRAP

## ASSEMBLY TIP

Read all instructions before beginning work on your model. Make sure you have all parts and supplies. Test-fit all parts together before applying any glue. If any parts don't fit properly, sand as required for precision assembly.

## PARTS AND SUPPLIES

Locate the parts shown below and lay them out on the table in front of you. In addition to the parts included in the kit you will also need:

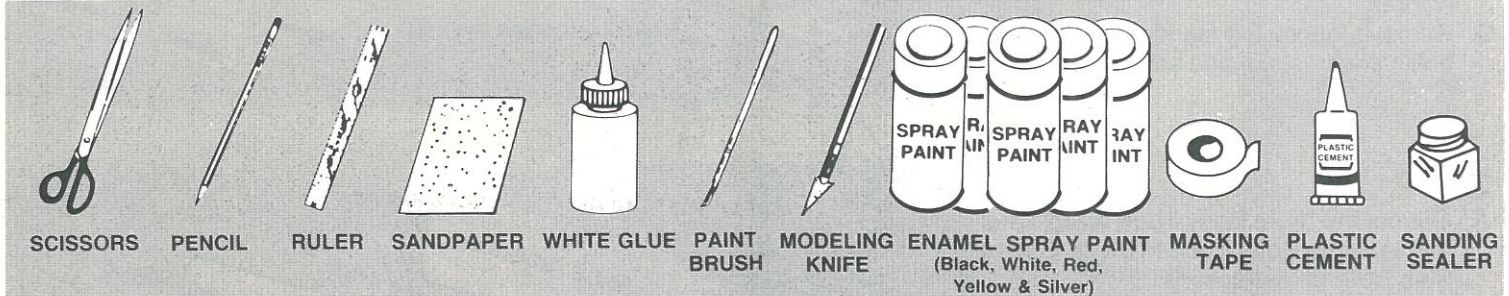

LARGE BODY TUBE (NIKE)

SMALL BODY TUBE (APACHE)

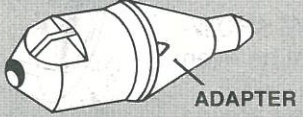

ADAPTER

NOSE CONE

NOSE CONE INSERT

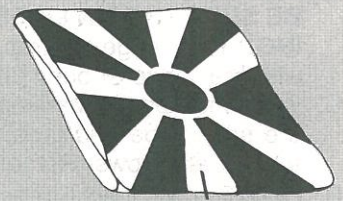

PARACHUTE



TAPE DISC



SHOCK CORD

LAUNCH LUG

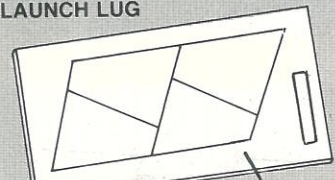

SHEETS OF PRE-CUT FINS

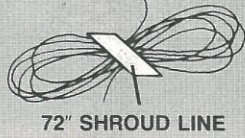

72" SHROUD LINE

INSTRUCTION "B"



DIE-CUT RING SET



ENGINE HOOK



ENGINE MOUNT TUBE

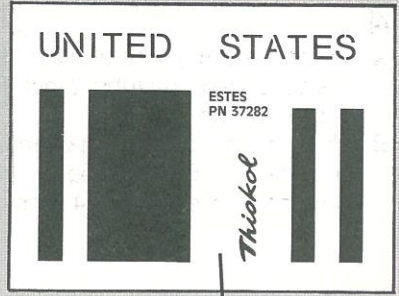

DECAL

# ROCKET ASSEMBLY

1

- Mark engine mount tube 1 inch and 2½ inches from one end.
- Cut 1/8 inch long slit at 2½ inch mark.
- Insert one end of engine hook into slit.
- Wrap masking tape around assembly twice at 1 inch mark.
- Slide slotted adapter ring onto rear of tube and up to masking tape. Slot fits over engine hook. Glue both sides of ring/tube joint.
- Slide remaining ring over front of tube and down to end of engine hook. Glue both sides of ring/tube joint.

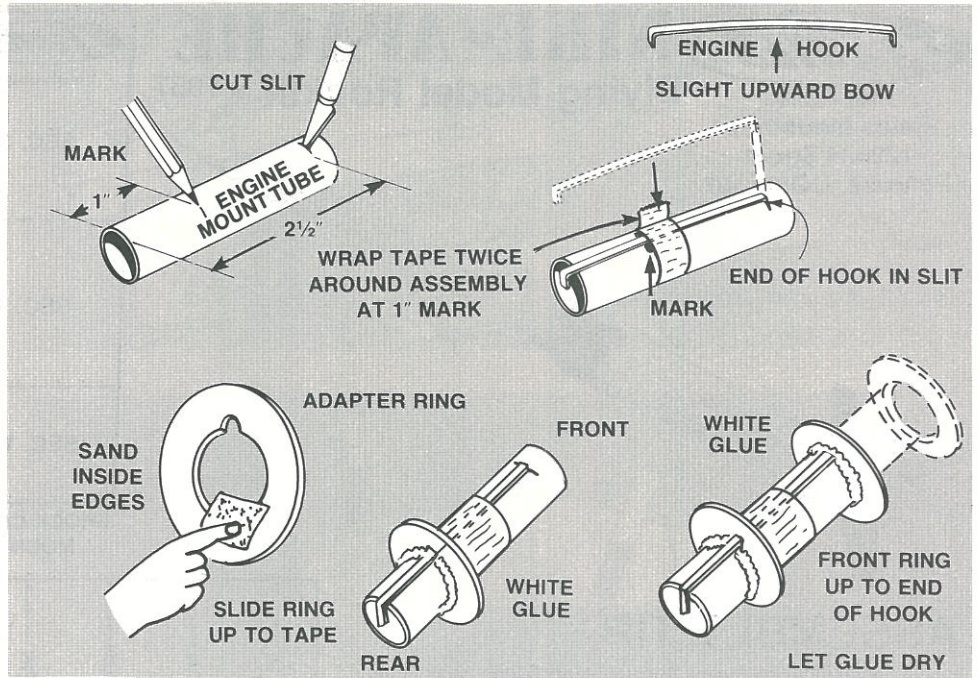

2

- Fine sand balsa die-cut sheets. Carefully remove fins by freeing edges with sharp knife.
- Stack fins together. Sand all edges smooth.
- Remove launch lug standoffs from large balsa sheet, sand, and save for step No. 6.

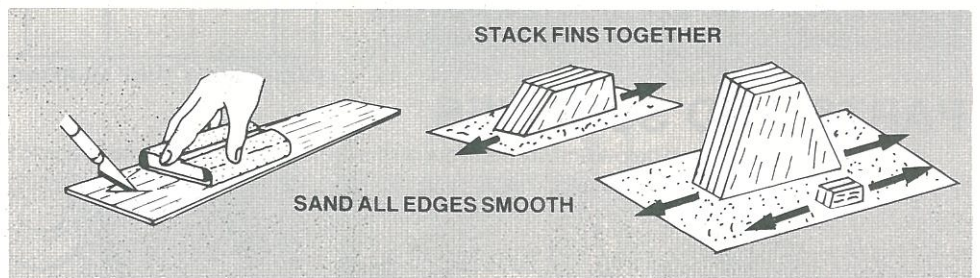

3

- Cut out the "Nike Body Tube Wrap", and the "Apache Body Tube Marking Guide" from front of instructions.
- Glue the Nike Wrap to one end of the large body tube.  
**BE SURE THE FIN LINES ARE SHOWING!!** Rear edge of wrap must be even with rear edge of body tube.
- Wrap the Apache Marking Guide around the small tube and tape in place. Mark tube at all arrows. Remove guide.
- Draw lines connecting each pair of marks on small (Apache) tube.

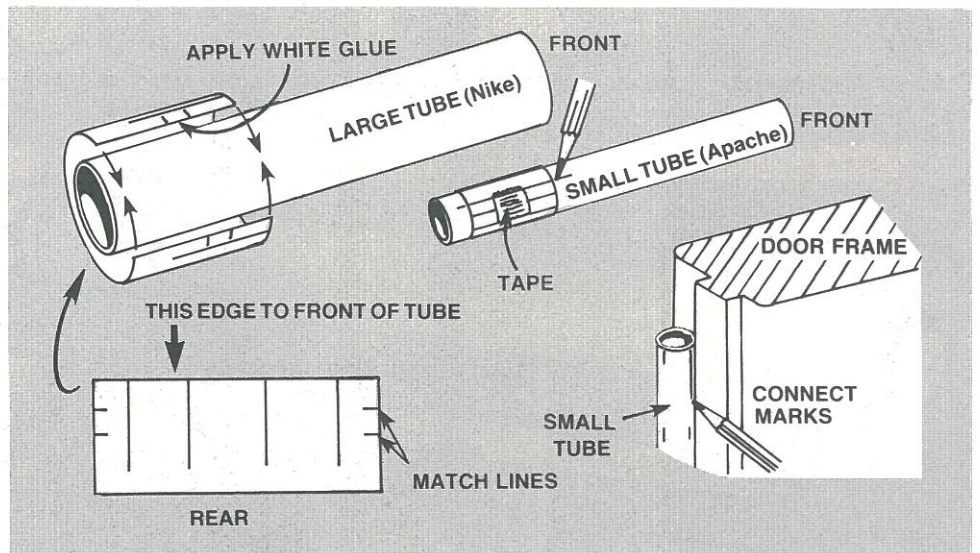

4

- Using a scrap piece of balsa, smear glue inside large body tube 2 inches from end with wrap on it.
- Push the engine mount in until tube ends are even. Engine hook will extend beyond end of tube 1/4 inch.

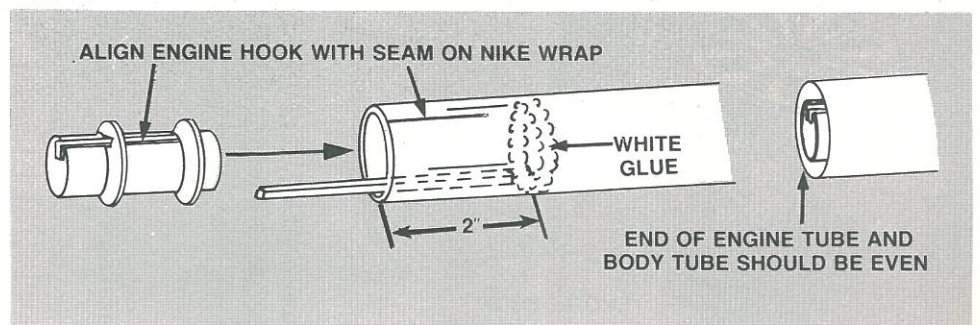

## 5

- Lay fins on pattern to find front (leading) and gluing (root) edges.
- Position and glue fins on alignment lines one at a time. Let each dry several minutes before applying the next one.
- Adjust fins to project straight out from tube.
- Do not set rocket on fins while glue is wet.

**FINS MUST BE ATTACHED CORRECTLY FOR STABLE FLIGHT!**

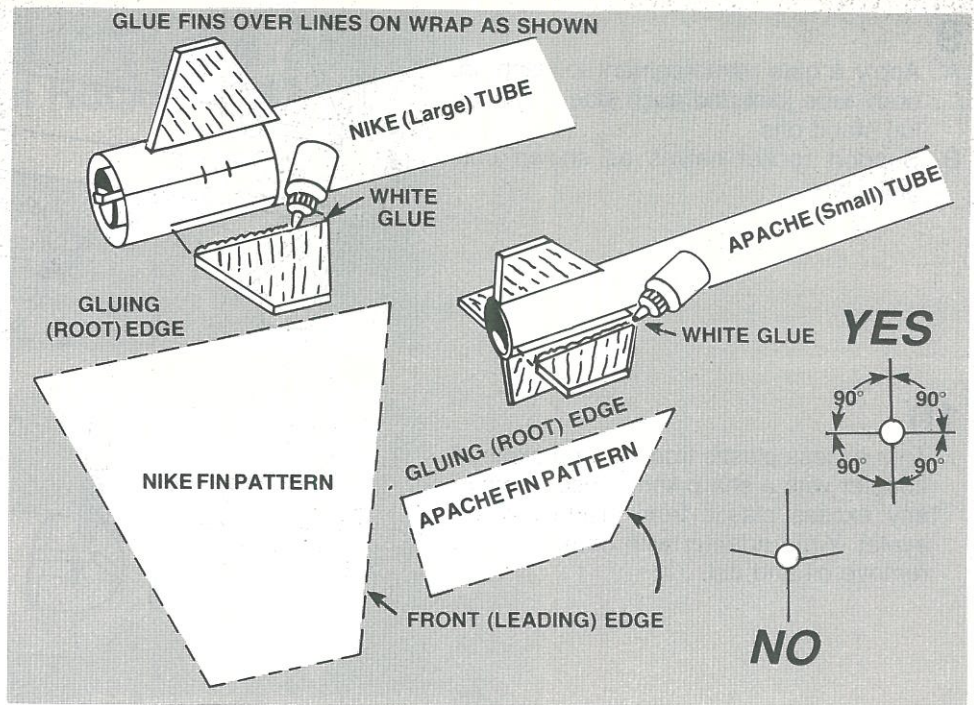

## 6

- Cut two (2) 3/8 inch pieces from the launch lug.
- Glue launch lugs to balsa standoffs saved from Step No. 2.
- Draw a straight line up the body tube using the wrap seam as a guide. Line must be parallel to body tube (See Step No. 3).
- Make a mark on this line 3 7/8 inches from front end of wrap.
- Glue completed launch lug assemblies in place as shown.

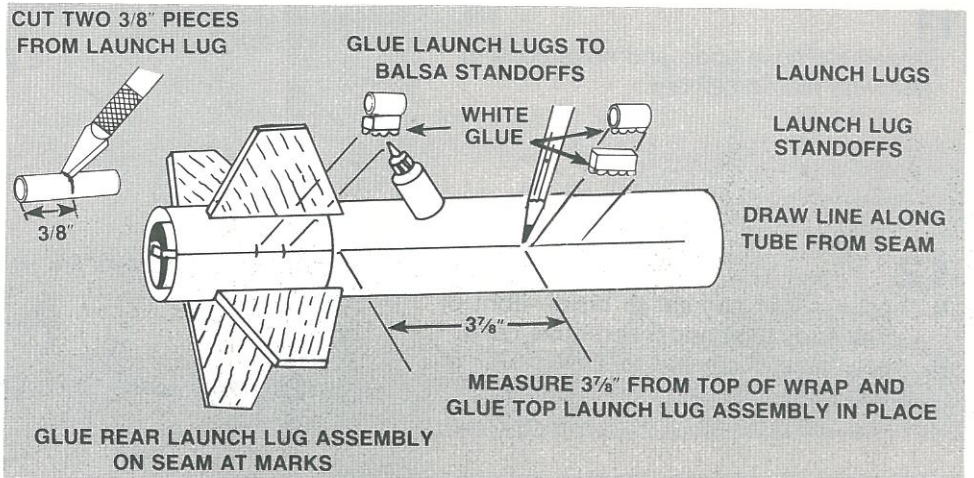

## 7

- Cut shock cord mount out from front page of instructions.
- Crease on dotted lines by folding. Spread glue on section 1 and lay end of shock cord into glue. Fold over and apply glue to back of first section and exposed part of section 2. Lay shock cord as shown and fold mount over again.
- Clamp unit together with fingers until glue sets.

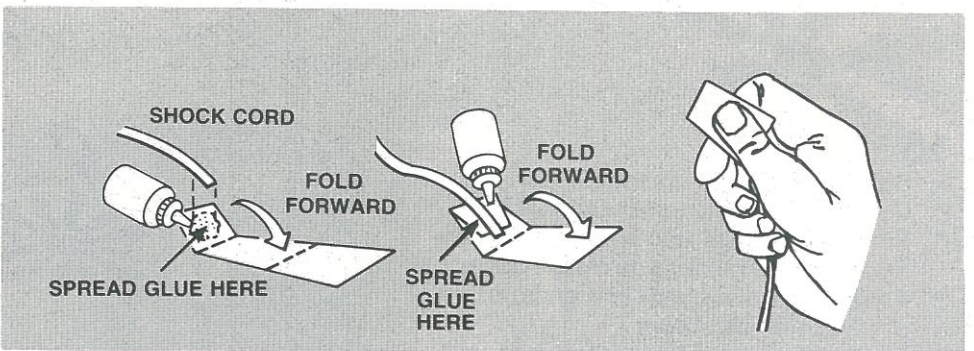

## 8

- Apply glue to inside front of large body tube to cover an area no less than 1 inch to 2 inches from end. The glued area should be same size as shock cord mount.
- Press mount firmly into glue as shown.
- Hold until glue sets.

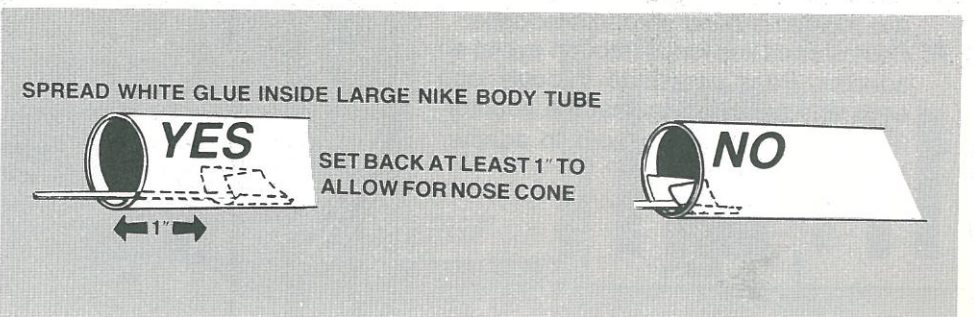

## 9

- A. Apply a glue reinforcement to each fin body tube joint and each side of launch lug stand offs.
- B. Support rocket halves as shown until glue dries.

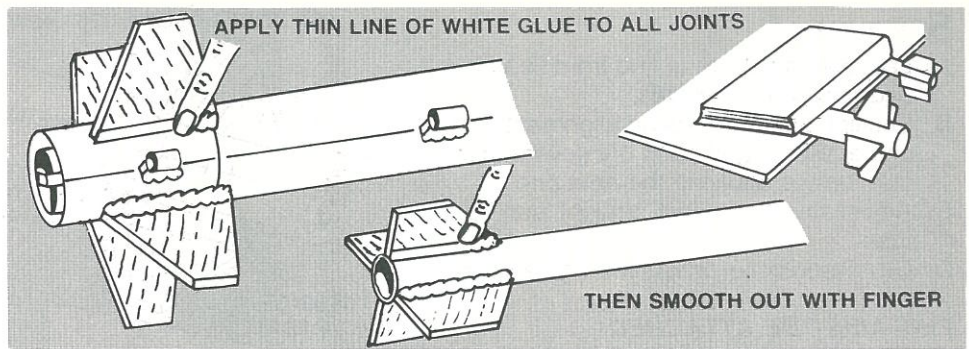

## 10

Trim excess plastic from around sides of adapter with a sharp knife. Also, remove any excess plastic from inside molded eyelet. Wipe adapter with damp cloth to remove oil and dirt.

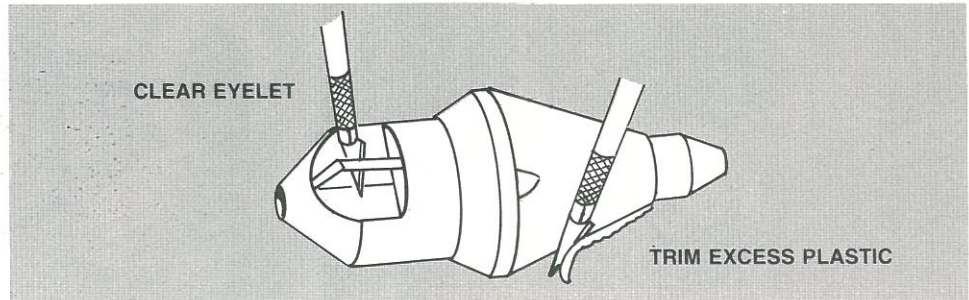

## 11

Assemble nose cone and nose cone insert with plastic cement.

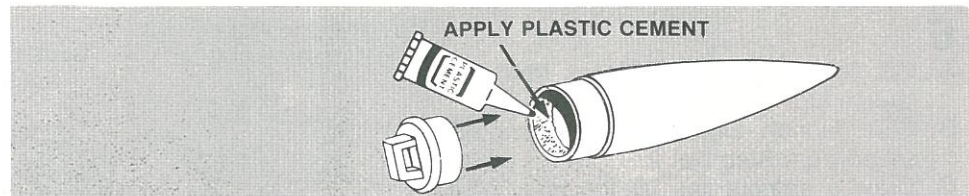

## 12

- A. Apply plastic cement to inside front of small body tube and insert nose cone.
- B. Apply plastic cement to inside rear of small body tube and insert adapter.

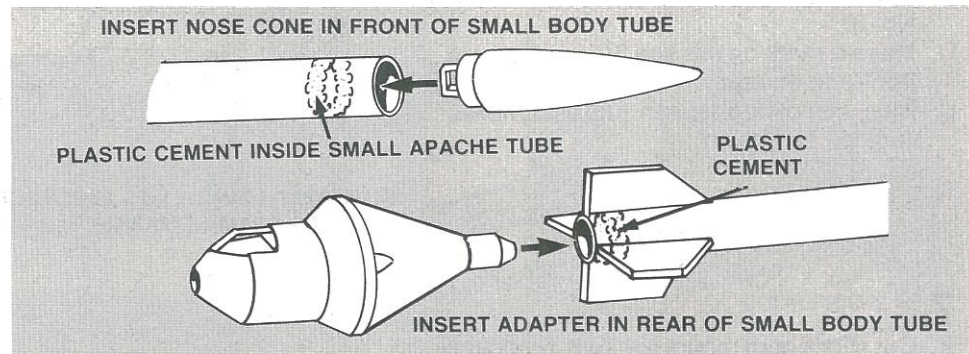

## 13

- A. Cut out parachute on edge lines.
- B. Cut three 23 inch lengths of shroud line.
- C. Form small loops with shroud line ends and press onto sticky side of tape discs.
- D. Attach tape discs with line ends to top of parachute as shown.
- E. Firmly press tape discs into place until both tape discs and parachute material are molded around shroud line loops.
- F. Pass shroud line loops through eyelet on adapter. Pass parachute through loop ends and pull lines against the adapter.
- G. Tie free end of shock cord to adapter loop.

