

ESTES
 A DAMON COMPANY
ESTES INDUSTRIES
 1295 H Street
 Penrose, CO 81240 USA

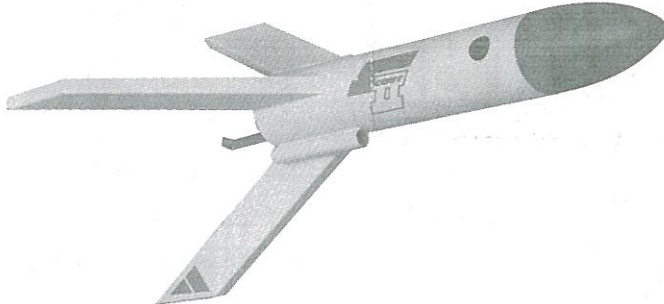
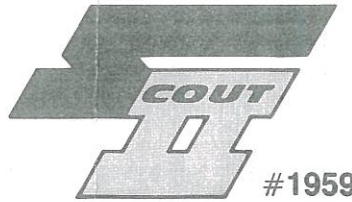

SCOUT II FLIGHT INFORMATION

Scout II is an updated version of the original Scout developed by Vernon Estes in 1959 and features tumble recovery. The thrust of the engine moves it forward in the rocket to make it fly a straight vertical (stable) flight pattern. At the highest point of flight (apogee) the engine's ejection charge pushes against the nose cone, pushing the engine back to the engine hook. This changes the Scout's center of gravity (CG) which causes it to begin tumbling end over end. This slows Scout II for a safe recovery.

ASSEMBLY TIP

Read all instructions before beginning work on your model. Make sure you have all parts and supplies. Test-fit all parts together before applying any glue. If any parts don't fit properly, sand as required for precision assembly.

PARTS AND SUPPLIES

Locate the parts shown below and lay them out on the table in front of you. In addition to the parts included in the kit you will also need:

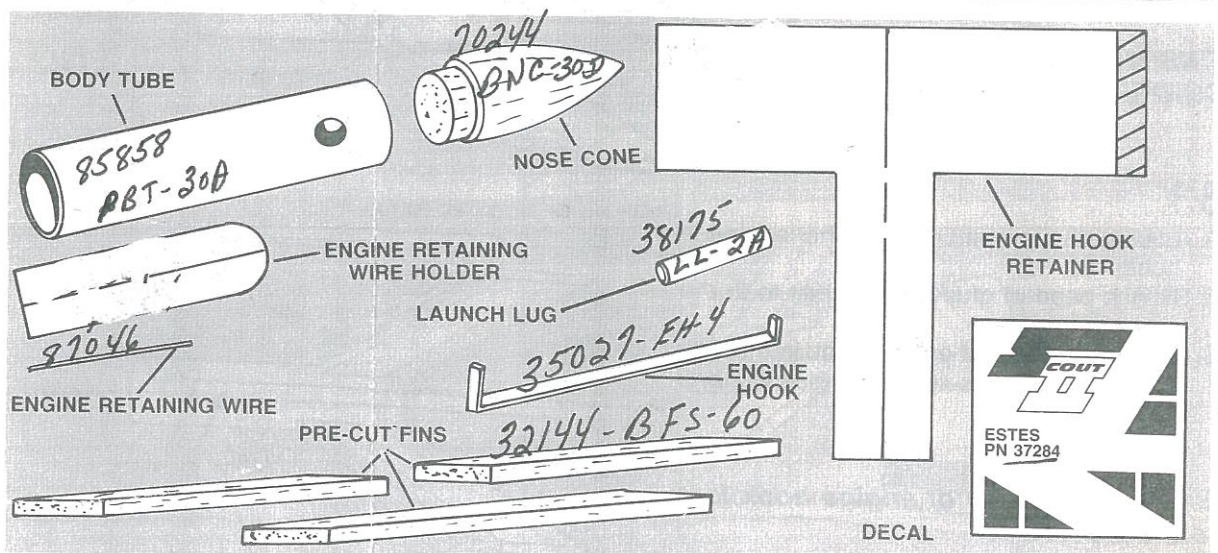
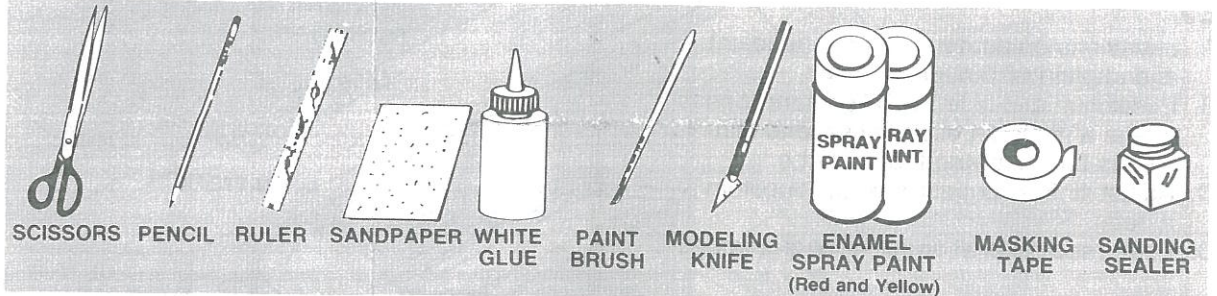

1

- A. Cut out tube marking guide here.
- B. Tape guide around tube so fin line with black dot is aligned with hole in front of body tube.
- C. Mark tube at arrows and mark "W" at the wire line.
- D. Draw straight lines connecting each pair of marks.

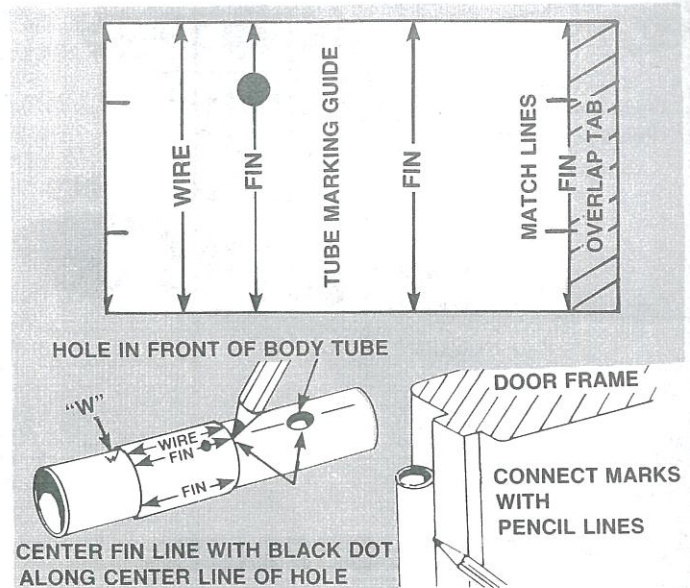

2

- A. Lay fins on pattern to find front (leading) and gluing (root) edges.
- B. Position and glue fins on alignment lines one at a time. Let each dry several minutes before applying the next one.
- C. Adjust fins to project straight out from tube.
- D. Do not set rocket on fins while glue is wet.

FINS MUST BE ATTACHED CORRECTLY FOR STABLE FLIGHT!

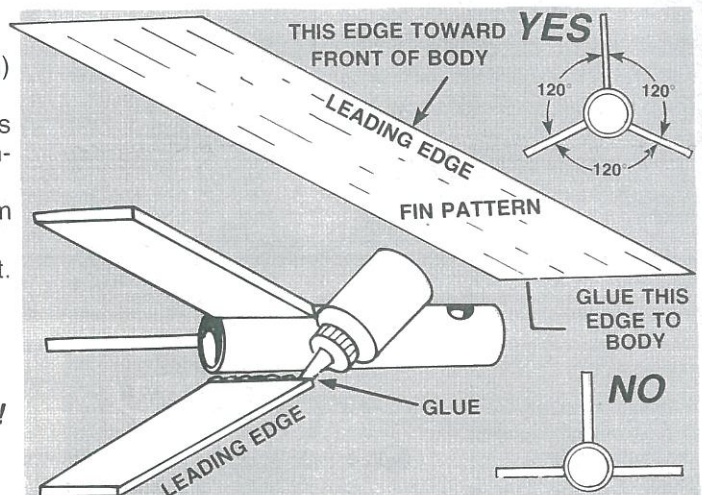

3

- A. Locate the pre-cut slit for the engine hook.
- B. Run a bead of glue from the slit to the rear of the tube.
- C. Press short end of engine hook into slit, press engine hook into the glue line and let dry.

Be sure long end of engine hook is to the rear!

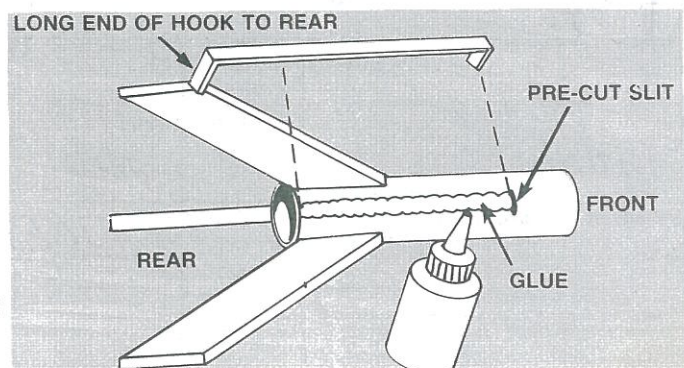

4

- A. Cut engine hook retainer from front of instructions.
- B. Smear thin layer of glue all over one side of retainer.
- C. Lay retainer over engine hook and wrap tightly around body tube. Allow assembly to dry.

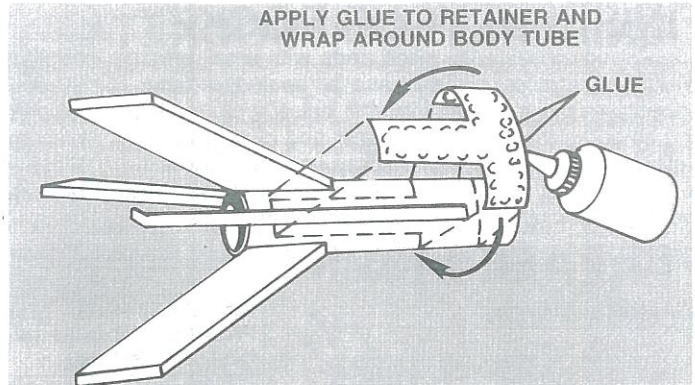

5

- A. Cut engine retaining wire holder out from front of instructions.
- B. Glue engine retaining wire along "W" line allowing 1/2 inch to extend over end of tube.
- C. Smear glue on one side of holder, and place it over wire.

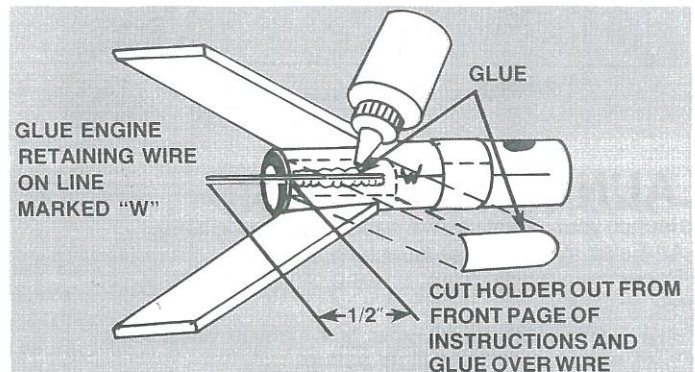

6

- A. Glue the launch lug along a fin/body joint as shown.
- B. Run a bead of glue inside the front end of the body tube and slide the nose cone into place.

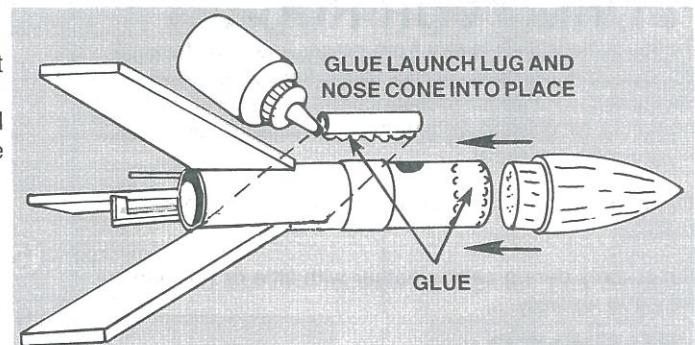

7

- A. Apply a glue reinforcement to both sides of each fin/body tube joint and each side of launch lug.
- B. Support rocket as shown until glue dries.

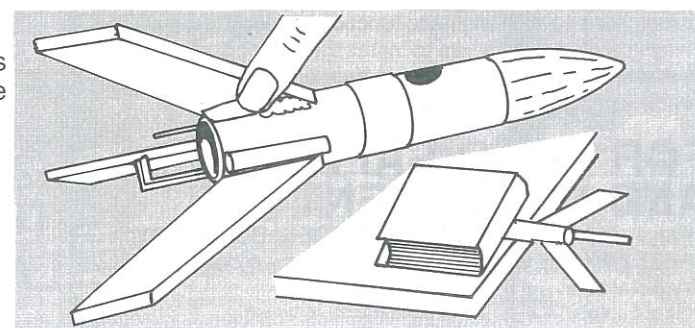

FINISHING YOUR ROCKET

Apply sanding sealer to wood parts with small brush. When sealer is dry, lightly sand all sealed surfaces. Repeat sealing and sanding until balsa grain is filled and smooth. When sanding sealer and glue are completely dry, paint model with spray enamel. Follow instructions on spray can for best results. Let paint dry overnight before masking to paint second color. To

apply decals, cut each out, dip in lukewarm water for 20 seconds and hold until it uncurls. Refer to photograph on front page and/or on front of panel for decal placement. Slip decal off backing sheet and onto model. Blot away excess water. For best results, let decals dry overnight and apply a coat of clear spray paint to protect decals.

PREPARE ENGINE

SEPARATE IGNITERS

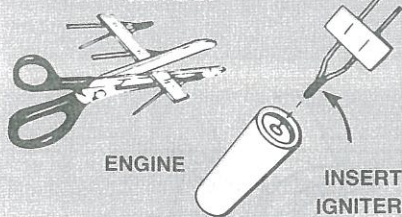

ENGINE

INSERT
IGNITER

IGNITER TIP MUST TOUCH
PROPELLANT DEEP INSIDE
NOZZLE OPENING

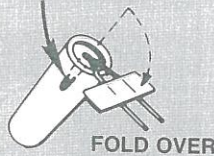

FOLD OVER

FIRMLY SECURE IGNITER LEADS AND RETAINING
WIRE WITH A PIECE OF MASKING TAPE

BEND ENGINE
RETAINING WIRE
OVER END OF
ENGINE

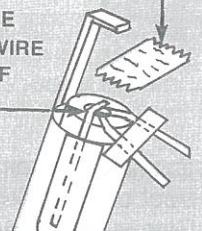

LAUNCH SUPPLIES

To launch your rocket you will need the following items:

- An Estes model rocket launching system
- Recommended Engines: 1/2A6-2, A8-3, B4-4, B6-4, B8-5, or C6-5

Use a 1/2A6-2 engine for your first flight to become familiar with your rocket's flight pattern.

FLYING YOUR ROCKET

Choose a large field away from power lines, tall trees, and low flying aircraft. Try to find a field at least 250 feet square. The larger the launch area, the better your chance of recovering your rocket. Football fields and playgrounds are great.

Launch area must be free of dry weeds and brown grass.

Launch only during calm weather with little or no wind and good visibility.

MISFIRES

Failure of the rocket engine to function properly is nearly always caused by a failure to install the igniter correctly. This failure permits the igniter to heat and burn into two pieces without igniting the engine.

FOR YOUR SAFETY AND ENJOYMENT

Always follow the NAR-HIA* MODEL ROCKETRY SAFETY CODE while participating in any model rocketry activities.

*National Association of Rocketry-The Hobby Industry of America
page 4

COUNTDOWN & LAUNCH

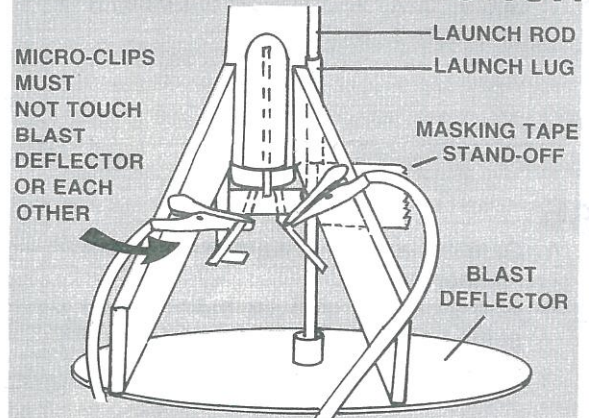

- 5 REMOVE SAFETY KEY to disarm the launch controller.
- 4 Remove safety cap and slide launch lug over launch rod to place rocket on launch pad. Make sure the rocket slides freely on the launch rod.
- 3 Attach micro-clips to the igniter wires. Arrange the clips so they do not touch each other or the metal blast deflector. Attach clips as close to protective tape on igniter as possible.
- 2 Move back from your rocket as far as launch wire will permit (at least 15 feet).
- 1 INSERT SAFETY KEY to arm the launch controller.

LAUNCH!! PUSH AND HOLD LAUNCH
BUTTON UNTIL ENGINE IGNITES
Remove safety key—Replace cap on rod.