

# CRUSADER SWING-WING GLIDER

#1961



A DAMON COMPANY

ESTES INDUSTRIES  
PENROSE, CO 81240 USA

WING HOLD DOWN  
REINFORCEMENT STRIP



## ASSEMBLY TIP

Read all instructions before beginning work on your model. Make sure you have all parts and supplies. Test-fit all parts together before applying any glue. If any parts don't fit properly, sand as required for precision assembly.

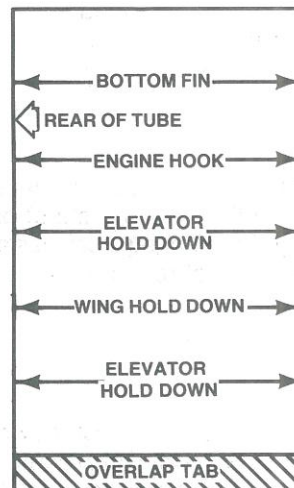

POWER POD  
MARKING GUIDE

## PARTS AND SUPPLIES

Locate the parts shown below and lay them out on the table in front of you. In addition to the parts included in the kit you will also need:

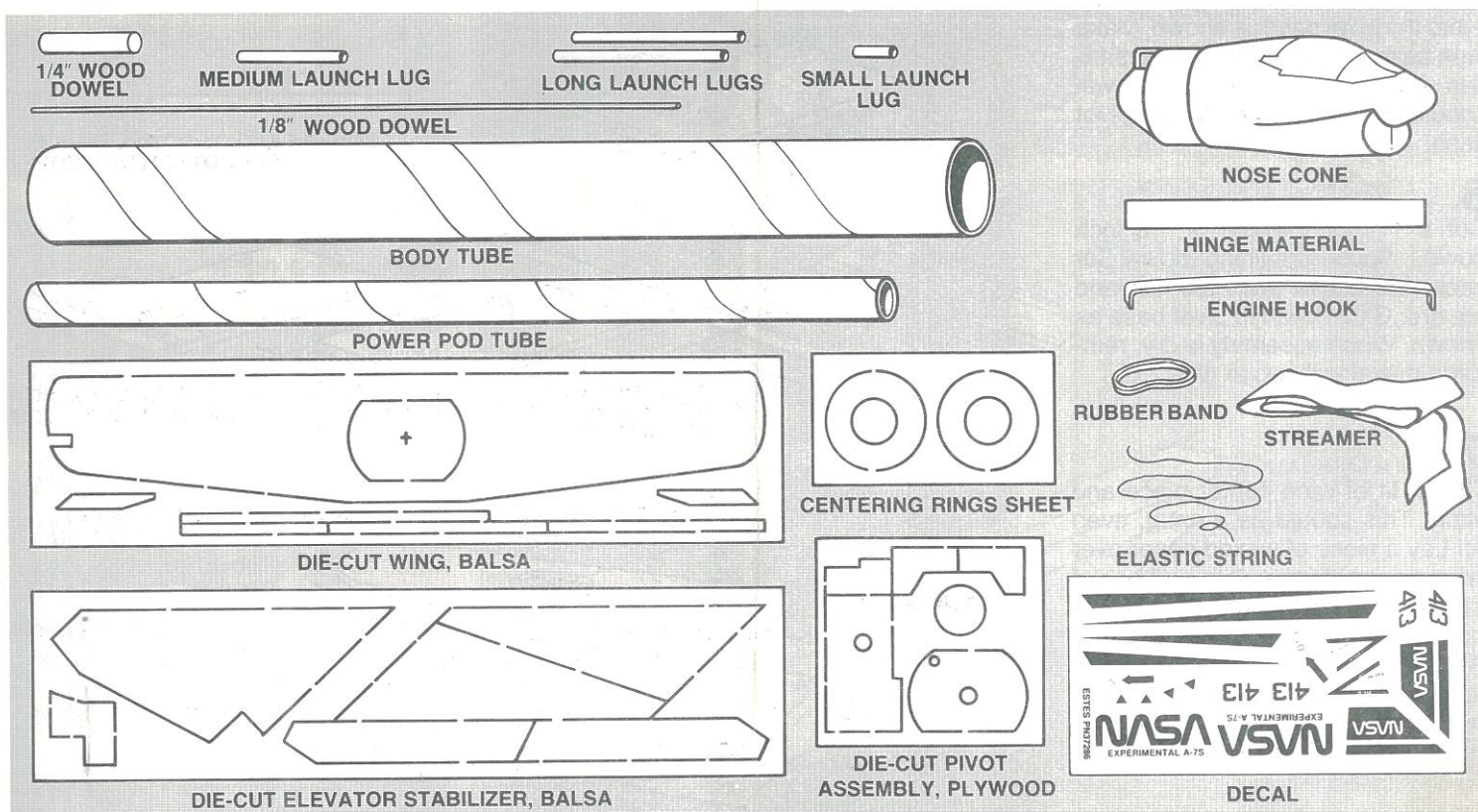
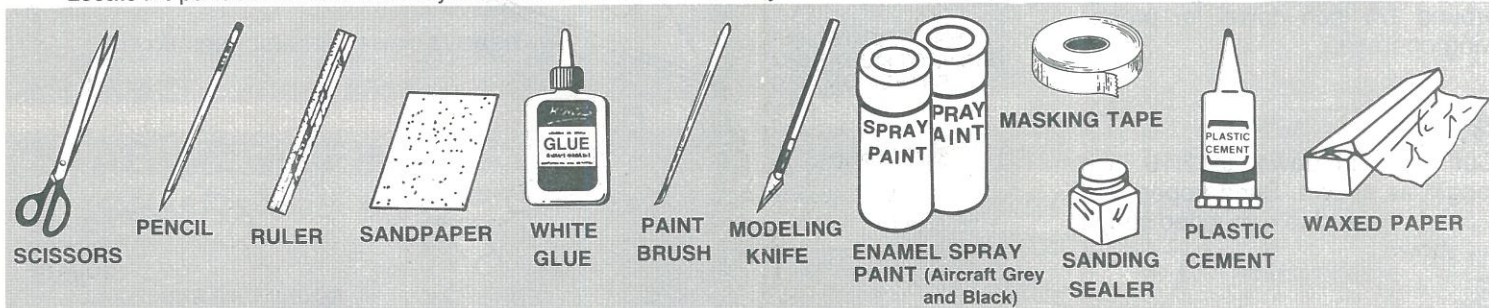

# WING AND PIVOT BASE ASSEMBLY

**1.**

Remove die-cut wing from balsa sheet. Remove half circle from center of wing. Lightly sand edges of wing and round edges slightly. Do not round edges of center hole or slot at end of wing.

**2.**

Remove the die-cut pieces shown from the plywood sheet only. Sand lightly to smooth surfaces and edges but do not round them.

**3.**

Check fit of 1/4 inch dowel in large holes of plywood pieces. It should be a smooth fit in pivot base and wing lock ring, and a relatively loose fit in wing center piece. Sand as necessary for proper fit of parts. Wing center piece must rotate freely around 1/4 inch dowel for proper wing operation.

**4.**

Cut 1/4 inch dowel to 7/16 inch length as shown. Sand upper 1/16 inch of one end to a rounded shape as shown.

**5.**

White glue 1/4 inch dowel from Step 4 into the pivot base as shown. Make sure assembly looks like the illustration shown. Square end of dowel should be flush with bottom of pivot base.

**6.**

Cut a 1 3/8 inch length of 1/8 inch dowel. Save remaining dowel for later use. Leave ends smooth and square. Glue dowel to pivot base as shown. When assembly is dry, reinforce dowel with white glue.

**7.**

Check fit of wing center piece and wing. This should be a snug, even fit. Lay a piece of waxed paper over wing assembly template on back of kit panel. Match location of 1/8 inch hole in center piece and template. Assemble and glue center piece and wing together. Before removing wing from template, mark center piece with a "T" for top of wing.

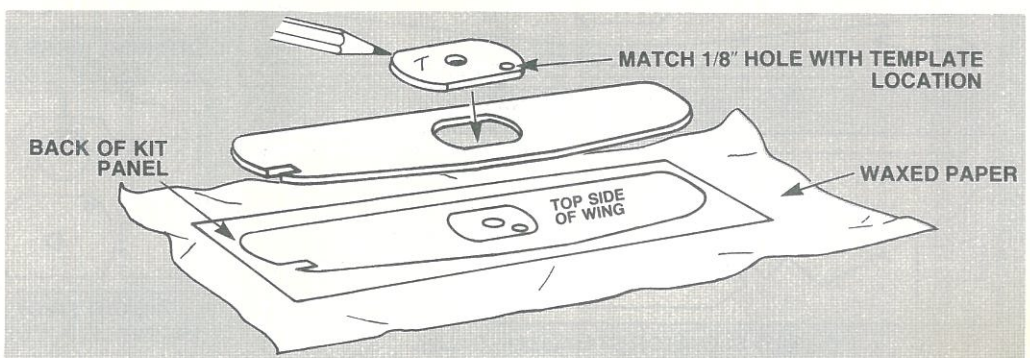
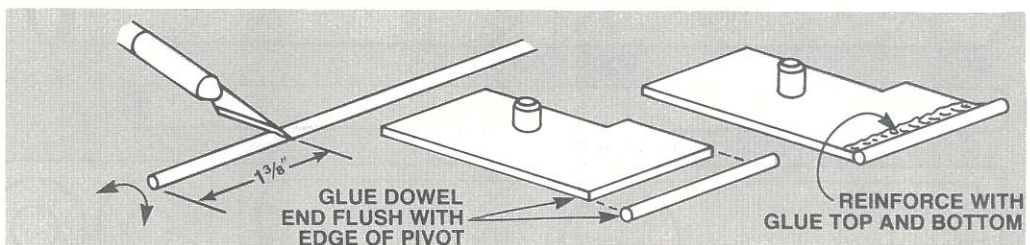
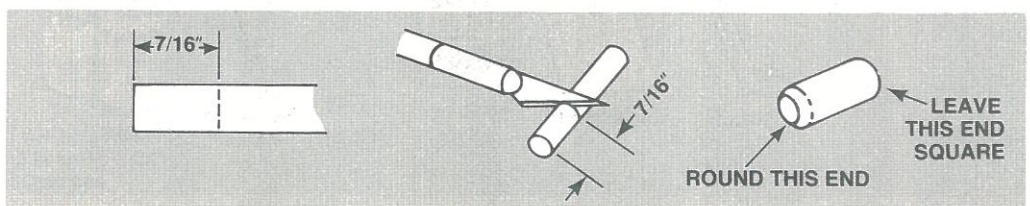
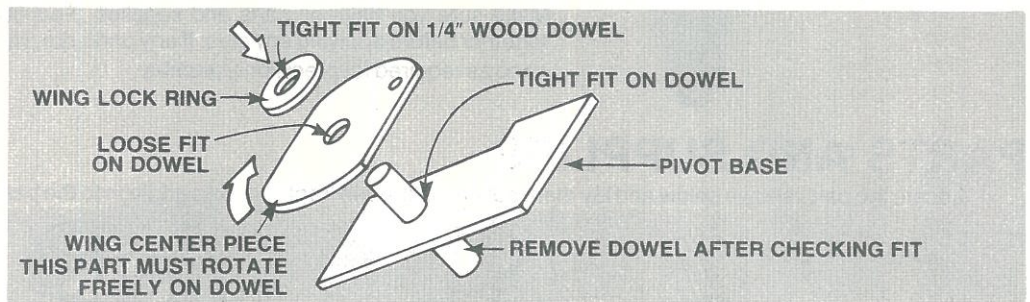
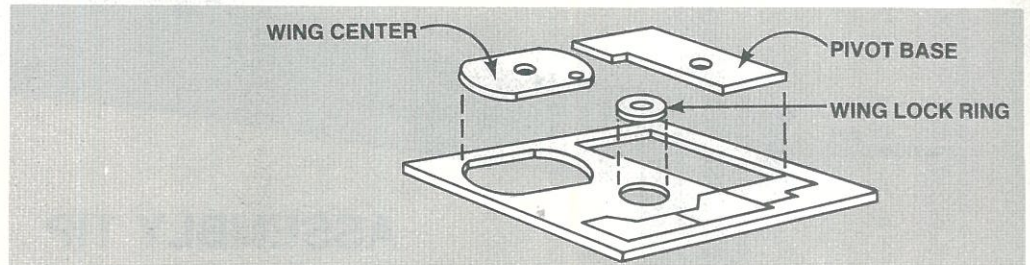
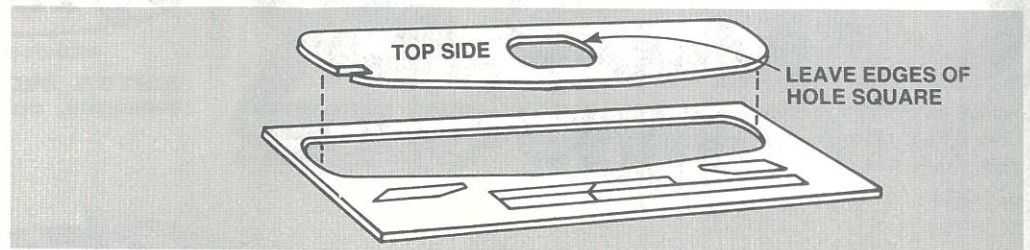

**8.** Cut a 3/8 inch length of 1/8 inch dowel as shown. Slightly round one end of dowel. Apply a small amount of glue to the hole. Place 3/8 inch dowel in hole on top side of wing and press through until end of dowel is even with top side of wing center piece. Apply a small white glue reinforcement to dowel and wing center piece.

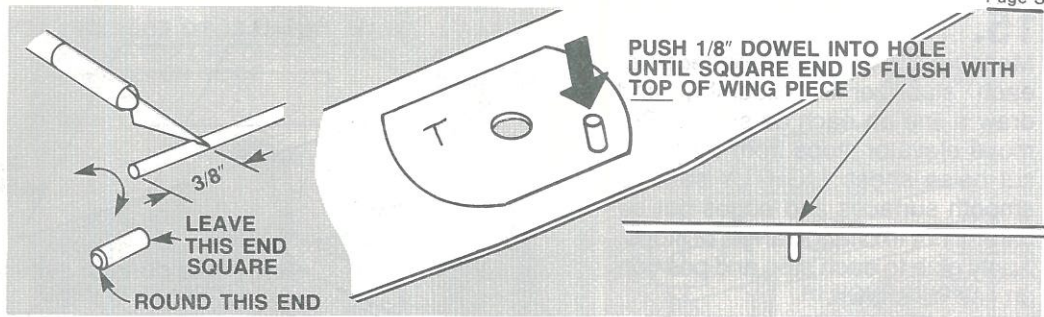

**9.** Glue one of the long launch lugs to the bottom of the pivot base as shown, so side of the launch lug is even with side of pivot base.

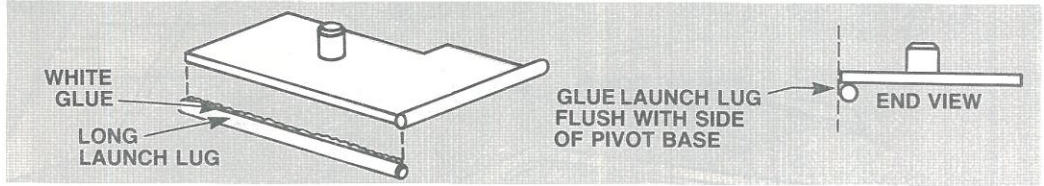

**10.** Place wing on pivot base and check for free pivoting action. The 1/8 inch dowel in wing will limit wing travel by striking end of slot in pivot base. Remove pivot base from wing and set aside for later assembly.

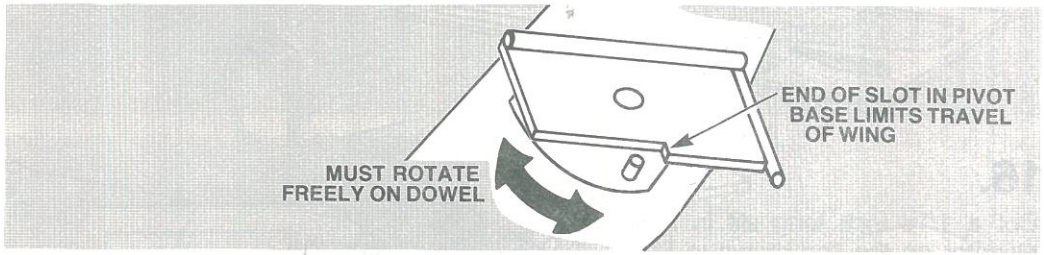

**11.** Glue shortest length of launch lug into slot at end of wing as shown.

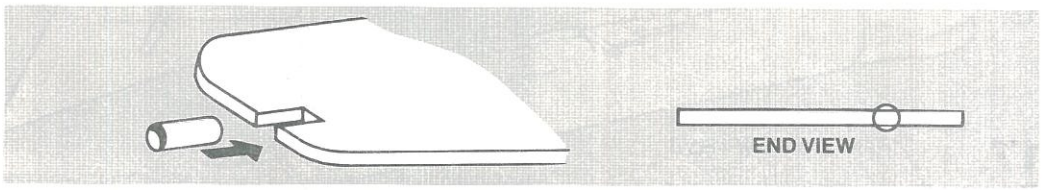

## STABILIZER/FIN ASSEMBLY

**12.** Remove stabilizer/fin parts from die-cut balsa sheet and sand LIGHTLY to round edges.

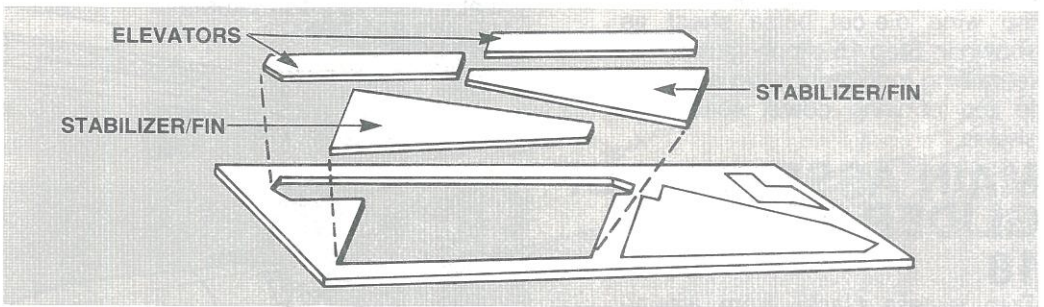

**13.** Apply sanding sealer to all surfaces of stabilizer/fins and elevators with a small brush. When sealer is dry, lightly sand all sealed surfaces. Repeat sealing and sanding until balsa grain is filled and smooth. Lay out parts as shown.

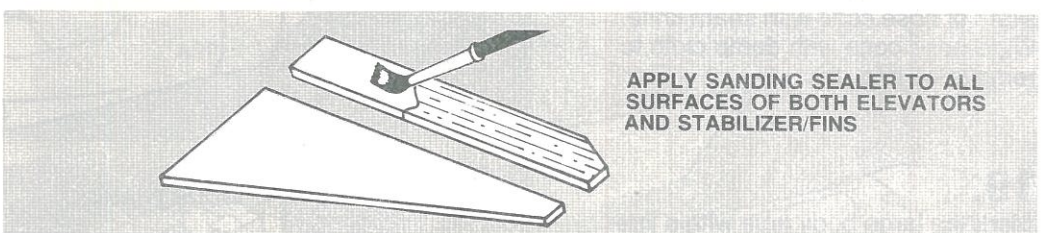

**14.** Cut the self-adhesive hinge material in half. Position elevators as shown and remove backing paper from hinge material and apply to elevator stabilizer/fin assembly as shown. Fold elevator up and down several times to crease hinge and to insure proper operation.

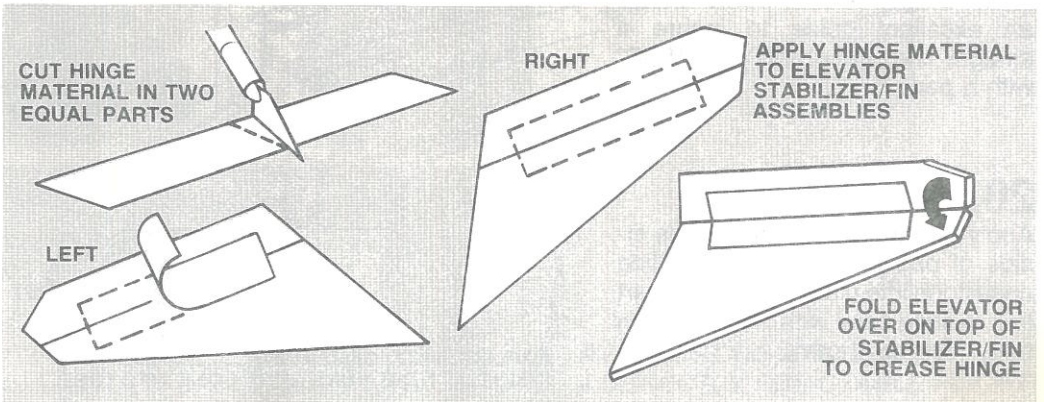

### 15.

Measure 1½ inch from root edge of each stabilizer/fin assembly and draw a line on each as shown. Remove elevator stops from wing die-cut balsa sheet. LIGHTLY sand to smooth surfaces and edges but be careful not to change angle of stops. Apply glue to each stop and position on line as shown.

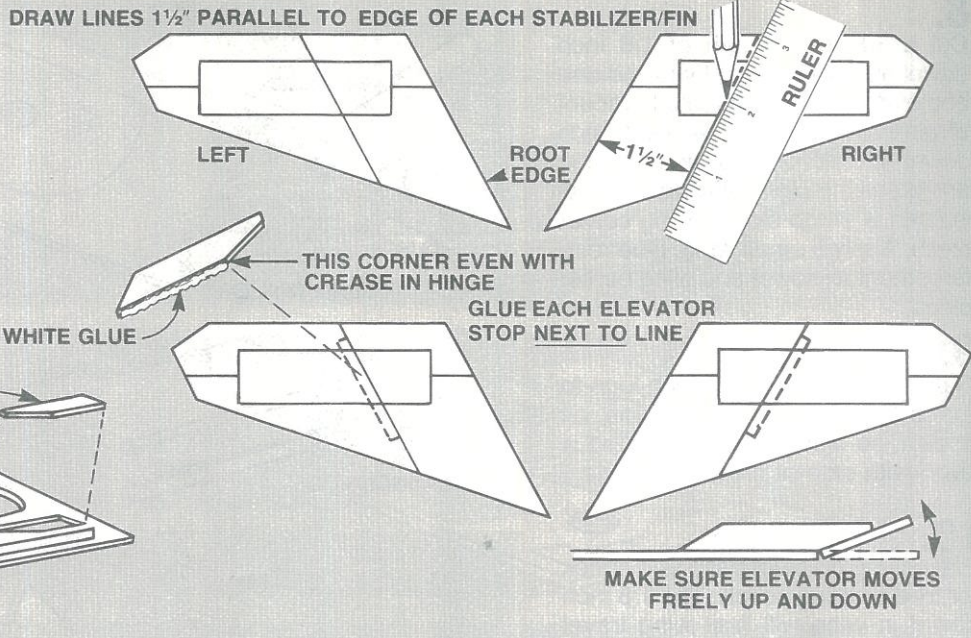
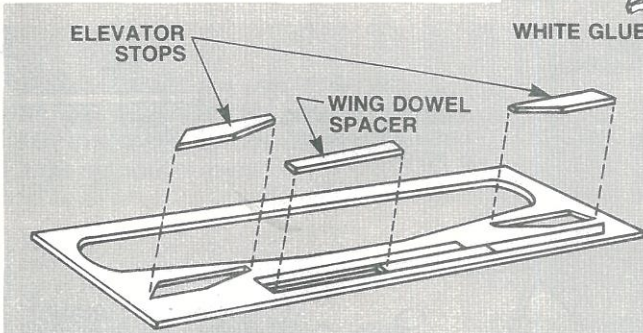

### 16.

Cut a 1/16 inch long slit in each elevator on the line drawn in Step 15.

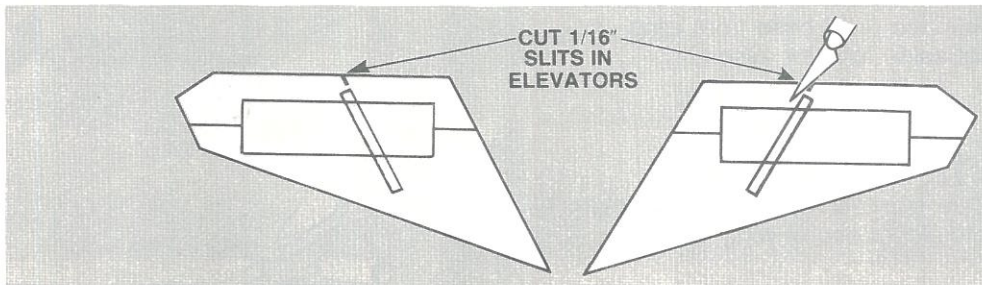

### 17.

Remove the wing dowel spacer from the wing die-cut balsa sheet as shown in Step 15. Apply glue to the remaining long launch lug and glue to top of wing dowel spacer as shown.

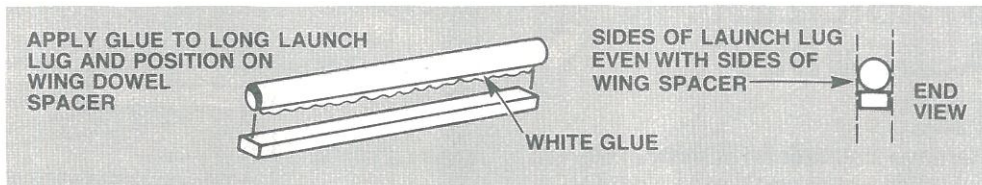

## MAIN ASSEMBLY OF GLIDER BODY

### 18.

Trim excess plastic from around sides of nose cone with sharp knife. Wipe nose cone with damp cloth to remove oil and dirt.

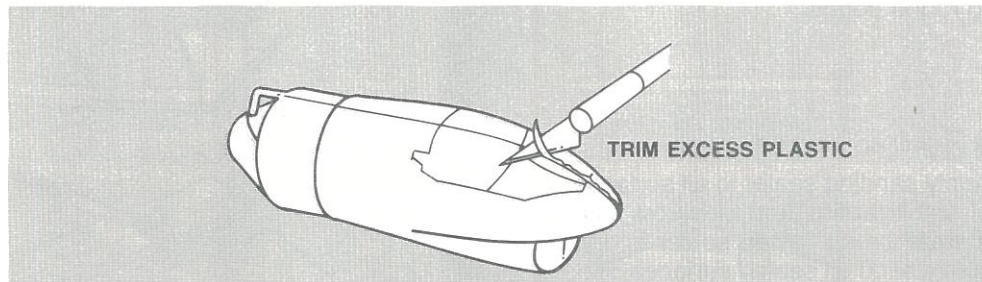

### 19.

Mark the large body tube with a line its full length. A door frame makes an excellent guide to insure a straight line. Label this line "TOP" with a pencil.

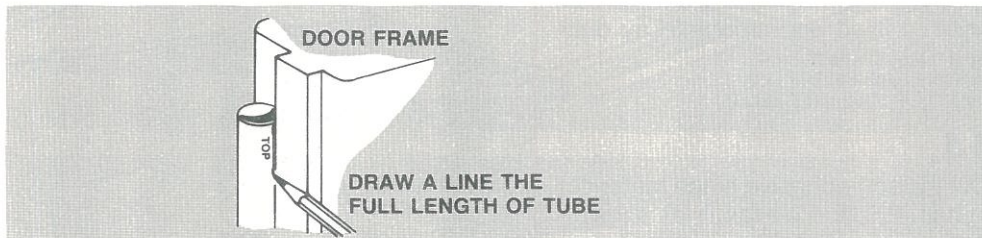

### 20.

Apply plastic cement around the inside of one end of the tube. Slide nose cone into place and center part line of nose cone with "TOP" line on body tube as shown.

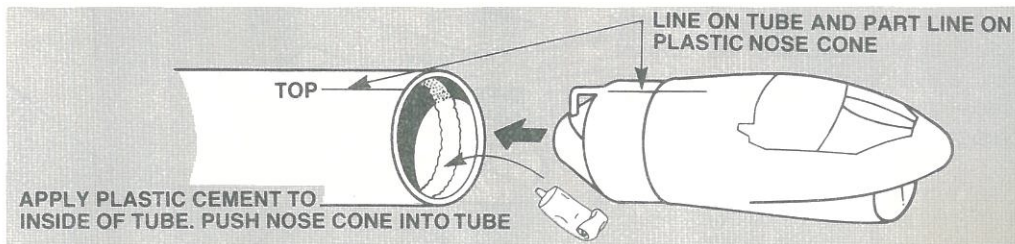

**21.**

Cut out the main body tube marking guide from back of kit panel and wrap guide around the tube with arrow labeled front pointing toward the nose cone end of glider body. Match up the top arrows on marking guide with top line on body tube and tape. Mark tube at arrows. Remove guide. Draw straight lines connecting each pair of marks. A drawer sill makes an excellent guide to insure a straight line.

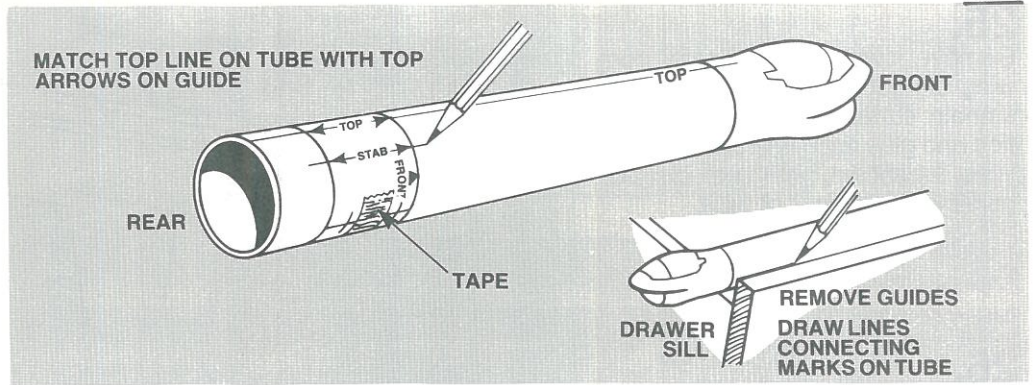
**22.**

Mark the "top" line on the body tube  $6\frac{3}{4}$  inch from the rear of the tube as shown. Mark the pivot base  $9/16$  inch from side of base as shown. Apply a line of glue to bottom side of launch lug and down center of pivot. Glue pivot to "top" line matching the mark on pivot with "top" line and rear of pivot even with  $6\frac{3}{4}$  inch mark.

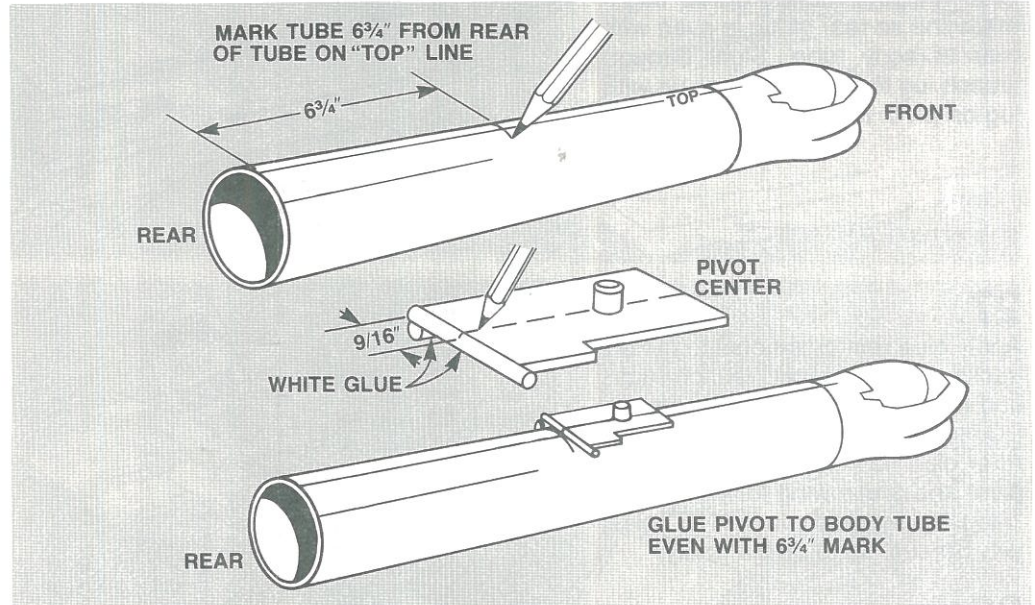
**23.**

Position and glue wing dowel spacer to "top" line with rear of spacer and rear of tube even.

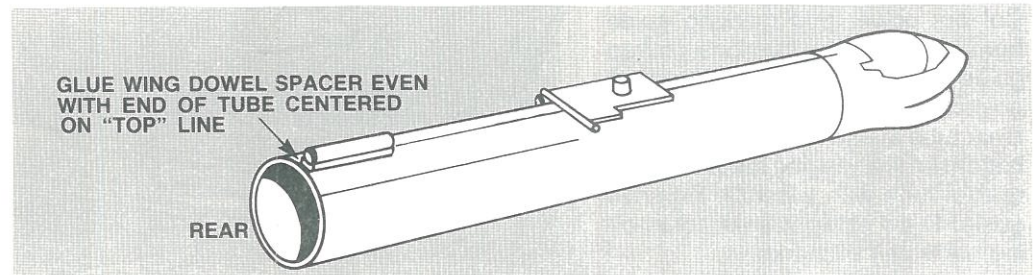
**24.**

Position and white glue stabilizer/fin assemblies on their alignment lines one at a time. Let each dry several minutes before applying the next one. Adjust fins to project straight out from tube.

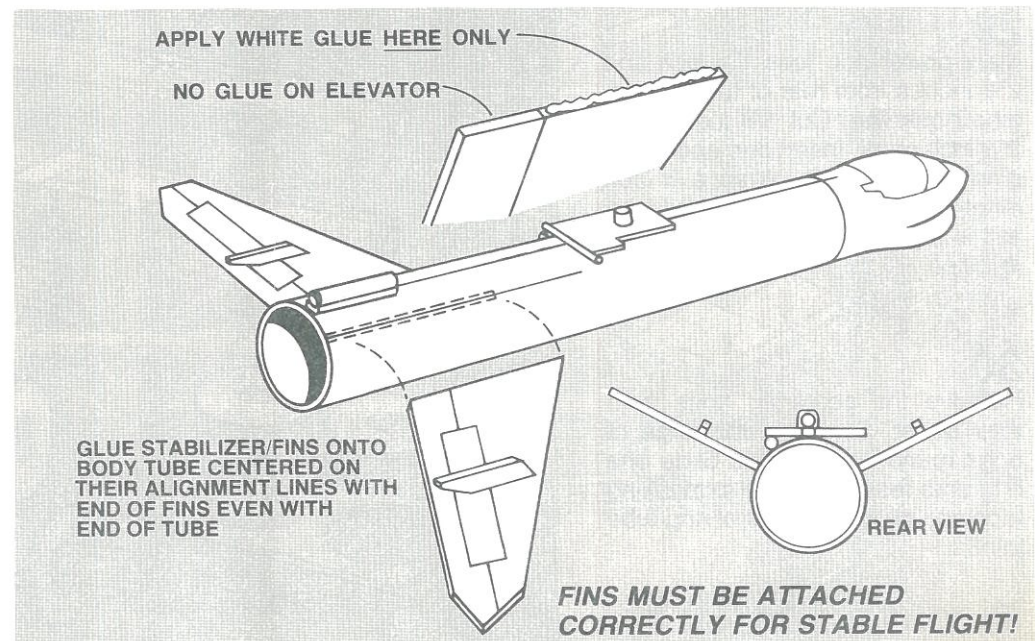

**25.**

Remove lower fin track parts from wing die-cut sheet. LIGHTLY sand smooth surfaces and edges. Position and glue each fin track between lines as shown, with rear of track part even with rear of tube.

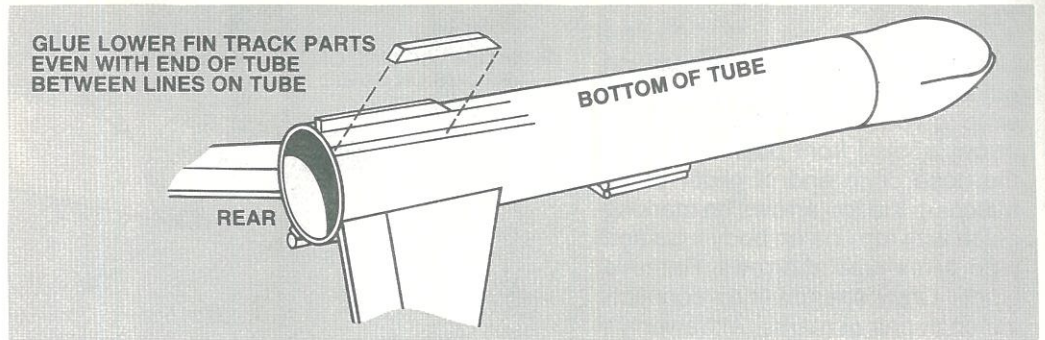

**26.**

Glue medium launch on its alignment line so rear of lug is even with rear of body tube. Sight through launch lug to be sure it lines up with lug on pivot assembly.

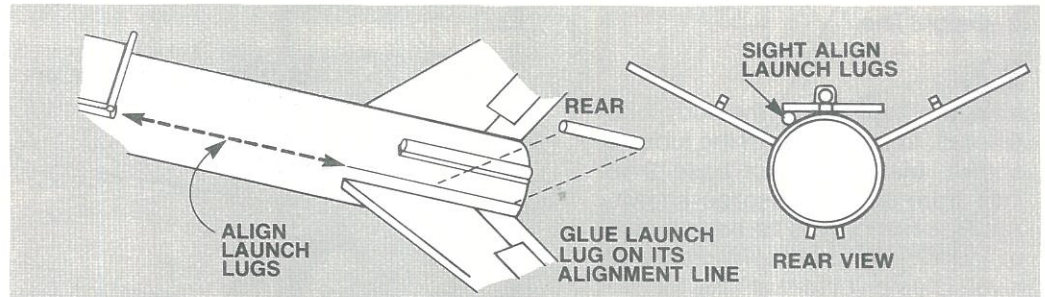

**27.**

Apply glue reinforcements to the fin tracks, dowel spacer, launch lugs, and to each stabilizer/fin assembly. DO NOT apply glue to the elevators. After glue has dried, place wing on pivot and press wing lock ring over 1/4 inch dowel in pivot. DO NOT glue yet. Be sure wing pivots freely.

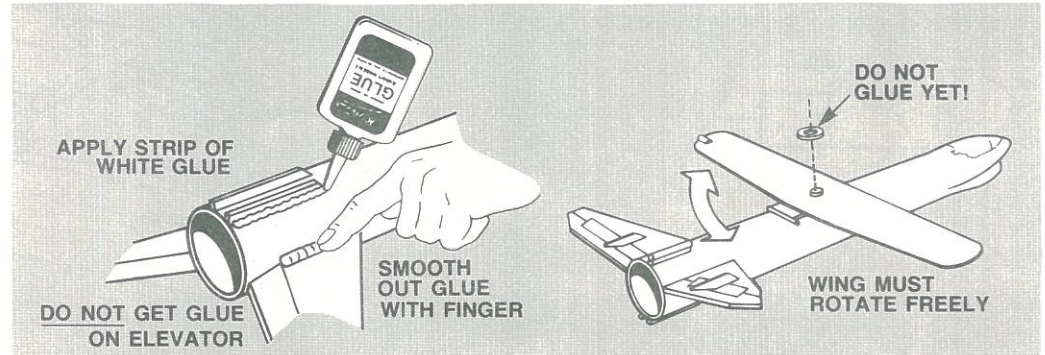

**28.**

Cut out power pod marking guide from front of instructions. Wrap guide around tube with rear arrow pointing to rear end of tube and tape. Mark tube at each arrow point. Label bottom fin line, engine hook line, and rear of tube with a pencil. Remove guide. Draw straight lines connecting each pair of marks.

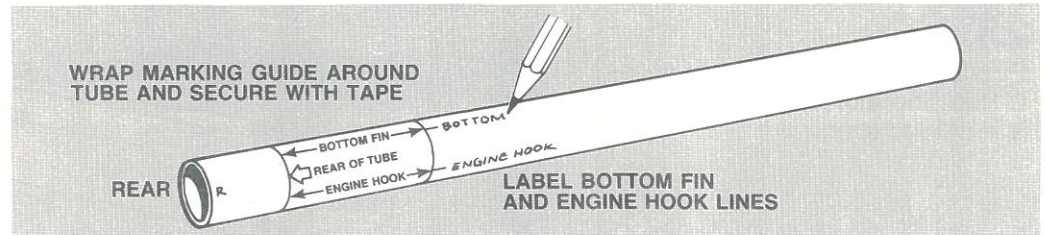

**29.**

Mark power pod tube 1 1/8 inch and 2 1/2 inches from rear of tube on engine hook line. Cut 1/8 inch slit at 2 1/2 inch mark. Insert one end of engine hook into slit. Wrap a 5 inch length of masking tape around tube at 1 1/8 inch mark to hold engine hook in place.

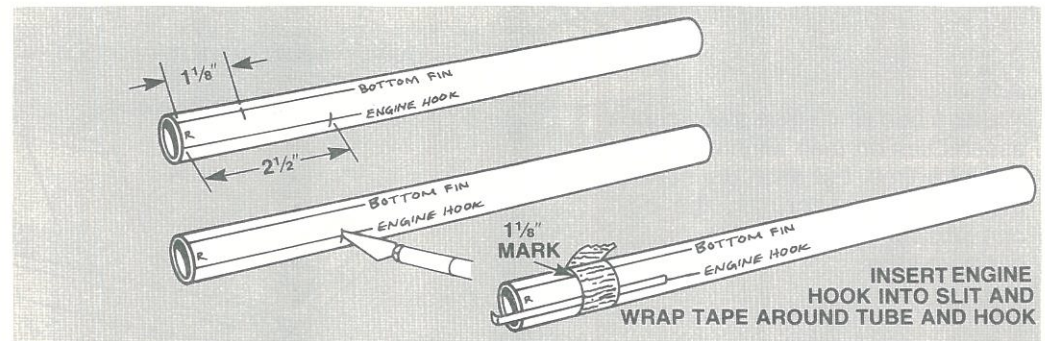

**30.**

Remove the centering rings from their sheet. Sand outside edge of rings round and smooth. Slide one ring onto rear of tube up to masking tape and glue both sides of ring/tube joint.

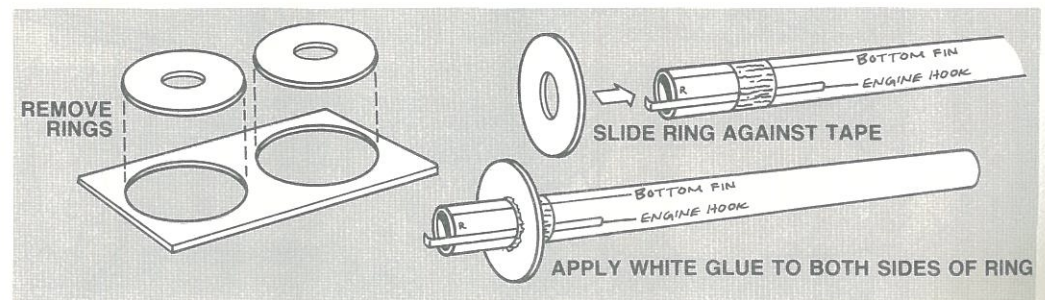

**31.**

Slide remaining ring onto front of tube 1/4 inch from end of tube. Glue both sides of ring/tube joint.

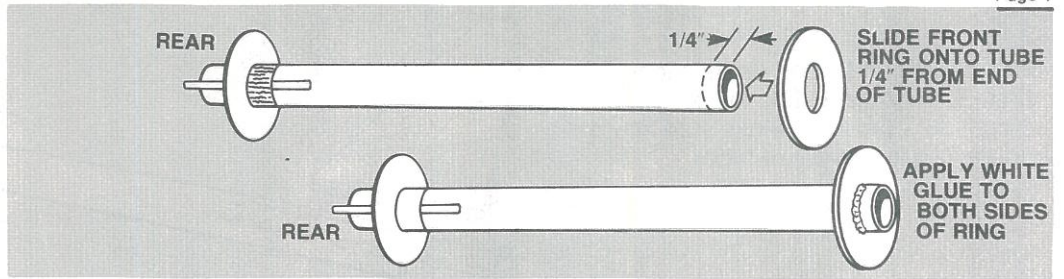

**32.**

Remove bottom fin parts from die-cut balsa sheet. Lightly sand to smooth edges only. Assemble over template on back of kit panel and waxed paper. Glue with white glue.

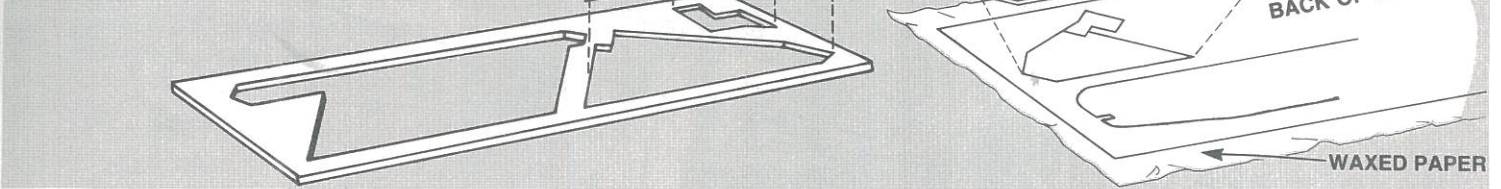

**33.**

Remove bottom fin stiffener strips from wing balsa sheet. Lightly sand to smooth edges. Remove bottom fin assembly from template when dry. Apply glue to edges of stiffener strips and glue to sides of fin assembly as shown.

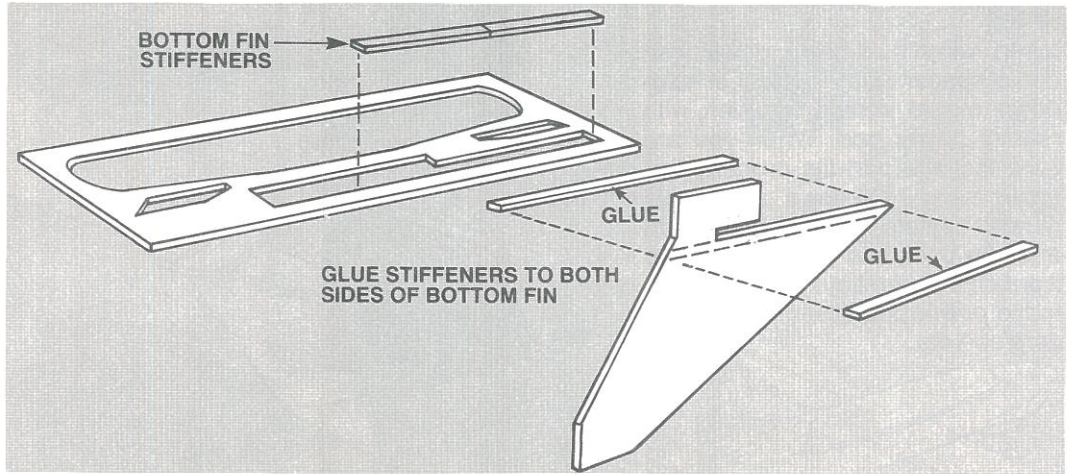

**34.**

Remove the three parts left in plywood die-cut sheet. Lightly sand to smooth edges. Cut two 5/8 inch long pieces and a 3 1/2 inch long piece from 1/8 inch wood dowel.

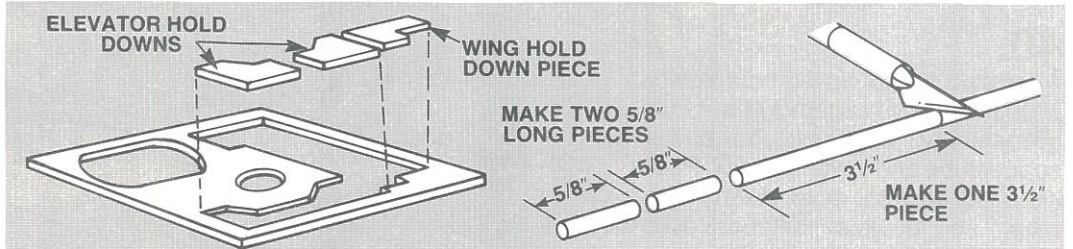

**35.**

Glue 5/8 inch long dowel to each elevator hold down piece and the 3 1/2 inch long dowel to the wing hold down piece. Cut out the wing hold down strip from front of instructions. Smear glue over hold down strip and glue it around wing hold down assembly for reinforcement.

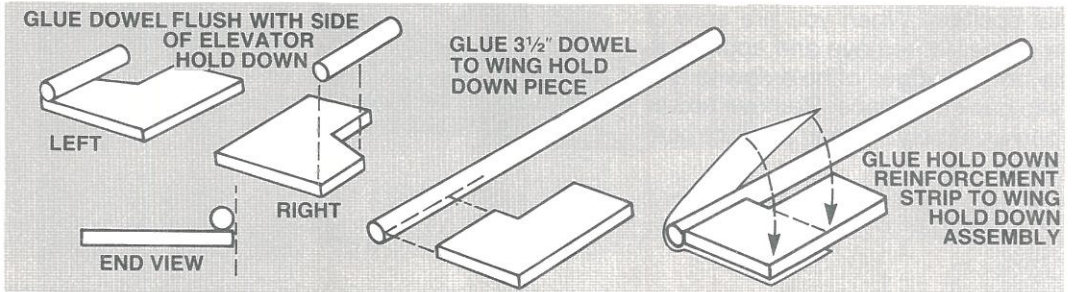

**36.**

Sand front of fin stiffeners round as shown.

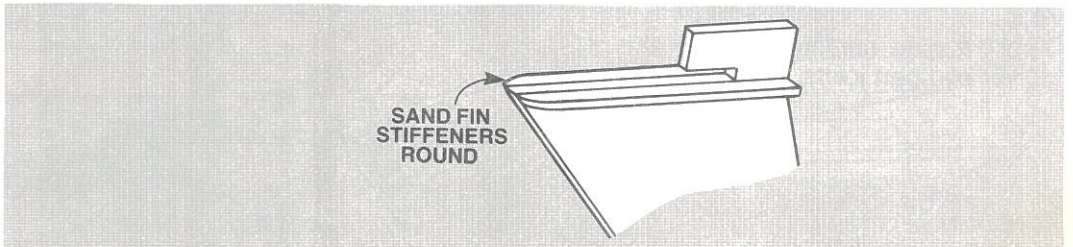

### 37.

Glue bottom fin to pod on its alignment line. Adjust fin to project straight out from tube. Make sure fin is parallel with center of tube.

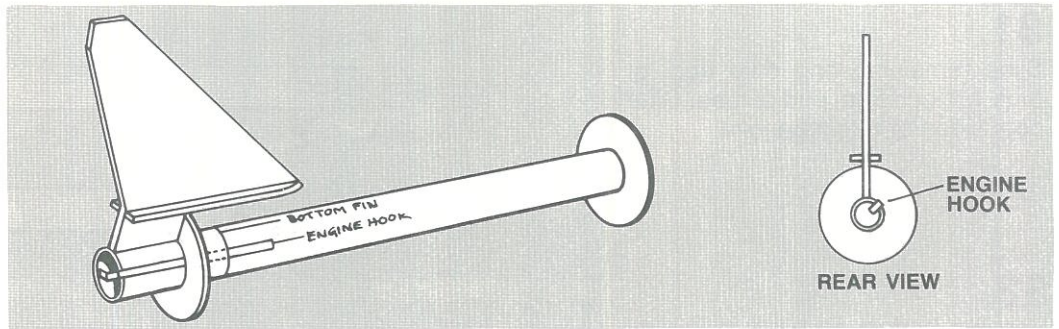

### 38.

When power pod and bottom fin are dry, slip power pod into rear of glider body tube. Bottom fin should slide into fin track on glider body freely. If necessary, sand centering rings and fin stiffeners for a loose sliding fit in body tube.

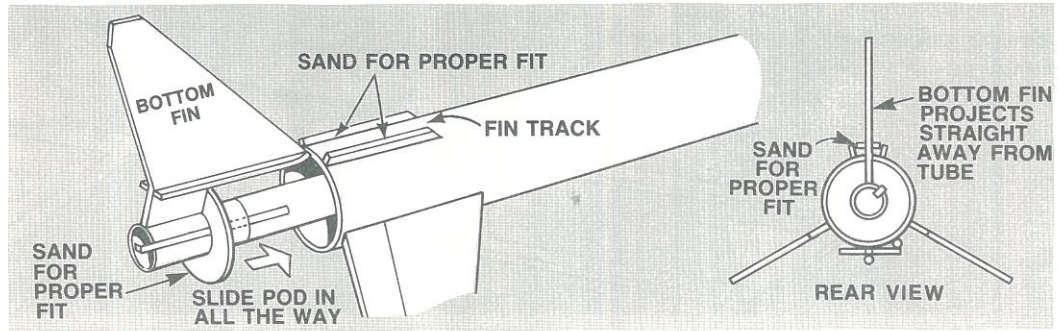

### 39.

Insert wing hold-down dowel into dowel spacer tube. The rear of hold-down mount should be even with rear of power pod. When you are sure that the part fits properly, remove wing hold-down and apply glue to bottom edge of hold-down and slip back into place. Adjust so it projects straight out from tube. Remove power pod assembly as soon as glue sets.

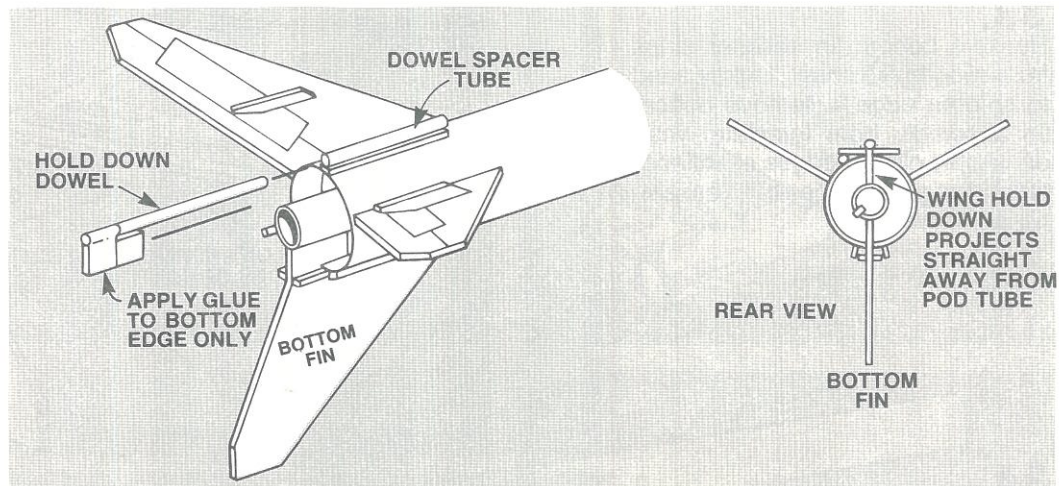

### 40.

After glue has dried on hold down, slide power pod assembly back into glider body, engaging the dowel spacer tube and lower fin track. Position the elevator hold downs into tube so dowels extend over elevators, holding them in a horizontal position. When you are sure of a proper fit, remove and apply glue to bottom edges of hold downs and slip back into place. Remove power pod assembly as soon as white glue sets.

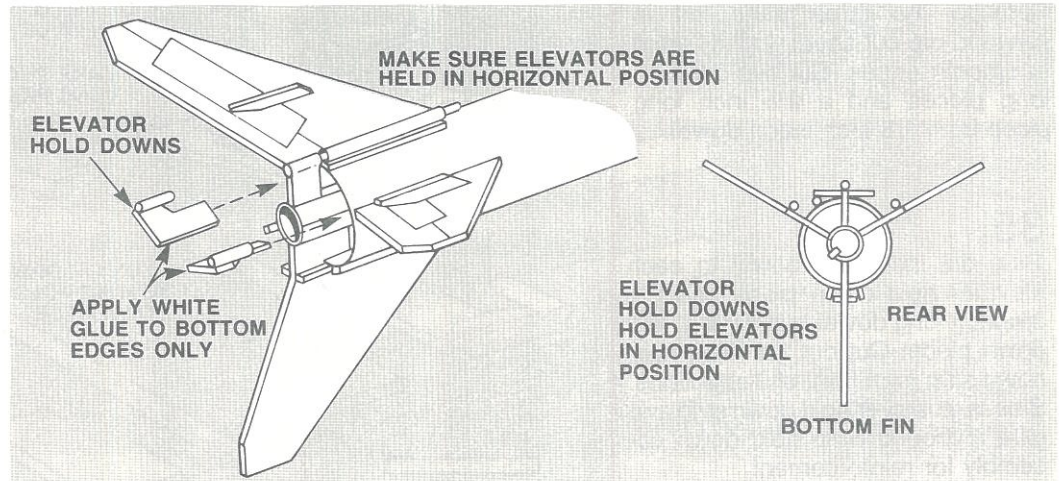

### 41.

Apply a glue reinforcement to all power pod part joints.

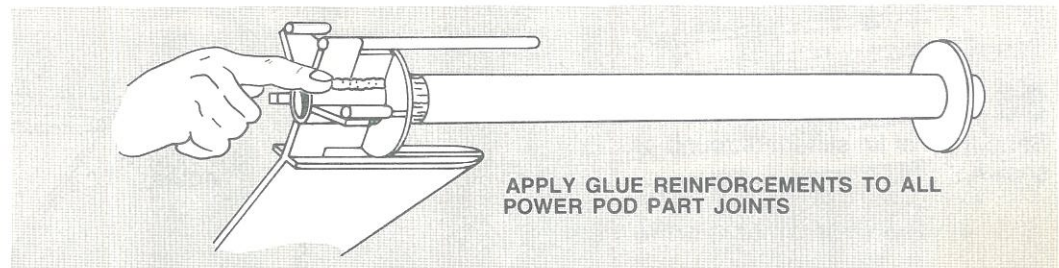



## 42.

Tie the center of the streamer tightly around power pod.

TIE STREAMER TO  
POWER POD

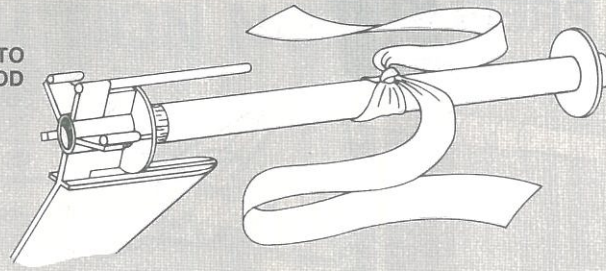

## PAINTING AND FINISHING

Apply sanding sealer to wood parts with small brush. When sealer is dry, lightly sand all sealed surfaces. Repeat sealing and sanding until balsa grain is filled and smooth. When sanding sealer and glue are completely dry, paint fuselage and wing aircraft grey. **For optimum performance, paint rocket with as little paint as possible to keep weight to a minimum.** Paint wing and fuselage separately. Paint back part of power pod black and lower fin grey. Follow instructions on spray can for best results. Let dry over night before assembling wing and fuselage, mask canopy and air scoop on nose cone and paint black. To apply decals, cut each out, dip in lukewarm water for 20 seconds, and hold until it uncurls. Refer to photograph on front page and on front of panel for decal locations. Slip decal off backing sheet and onto model. Blot away excess water. For best results, let decals dry over night and apply a light coat of clear spray paint to protect decals.

PAINT  
THIS AREA  
BLACK

PAINT LOWER  
FIN, WING  
AND BODY  
GRAY

MASK AND PAINT BLACK  
AS SHOWN

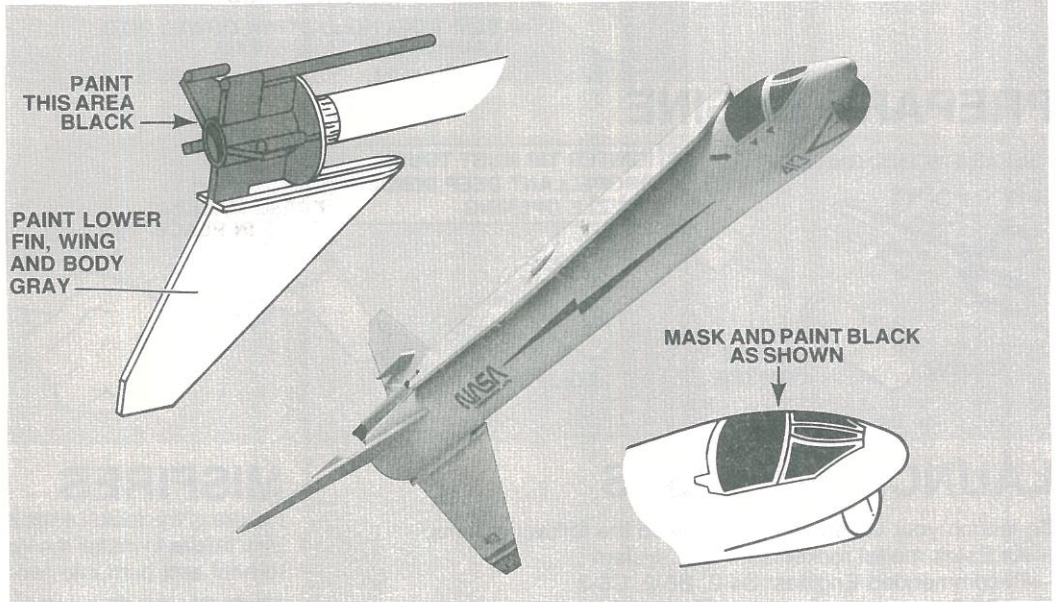

## 43.

Place wing on pivot and press wing lock ring over 1/4 inch dowel in pivot. Be sure wing pivots freely. Run a bead of glue around 1/4 inch dowel as shown. Allow to dry thoroughly. Check pivot again, wing must pivot freely.

WHITE GLUE

WING MUST  
ROTATE FREELY

APPLY GLUE AROUND 1/4" DOWEL  
AND ON WING LOCK RING  
CHECK ROTATION OF WING

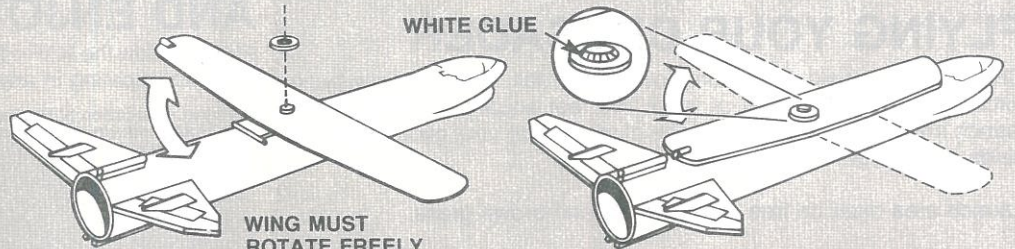

## INSTALLING RUBBER BAND AND ELASTIC THREAD

## 44.

Hook one end of rubber band over 1/8 inch dowel extending down from wing. Pull rubber band back and extend loop over dowel at back of pivot.

HOOK RUBBER BAND AROUND DOWEL ON WING

PULL RUBBER BAND BACK  
(LOOP OVER DOWEL ON PIVOT)

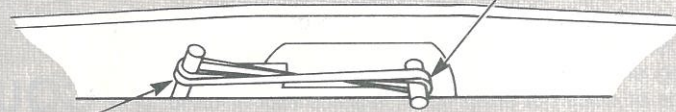

## 45.

Tie two knots in elastic thread 3 1/8 inches apart with thread not stretched. Stretch thread through notches in elevators and around wing dowel spacer. Be sure elevators move up against elevator stops. Cut excess thread away and save for possible repairs.

TIE TWO KNOTS IN ELASTIC THREAD 3 1/8" APART

KNOT IN SLOT

CUT OFF EXCESS THREAD

SIDE VIEW

ELEVATOR MOVES  
AGAINST ELEVATOR STOP

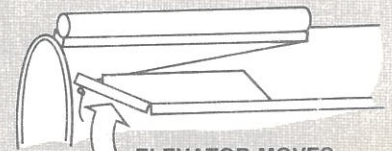
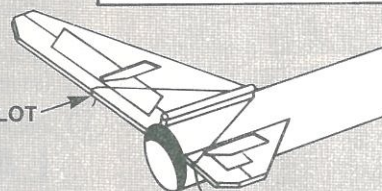
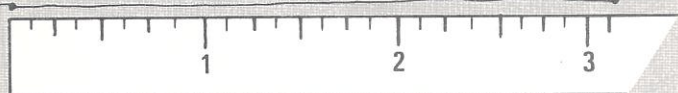

# ROCKET PREFLIGHT

## 1. WRAP STREAMER AROUND POWER POD

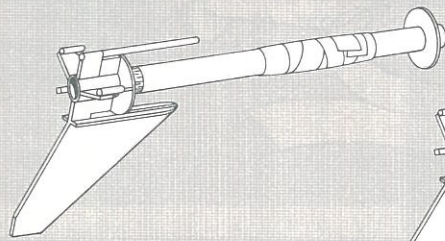

## 2. PIVOT WING TO BOOST POSITION

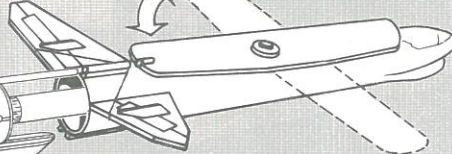

## 3. SLIDE POWERPOD INTO CRUSADER BODY

## 4. SLIP WING HOLD DOWN DOWEL INTO LAUNCH LUG ON WING TIP

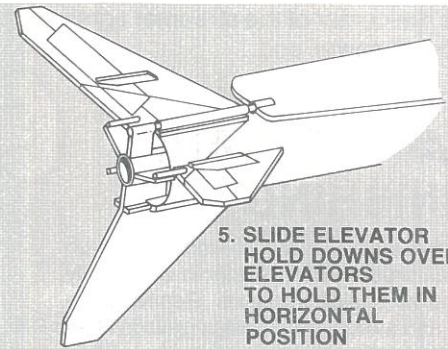
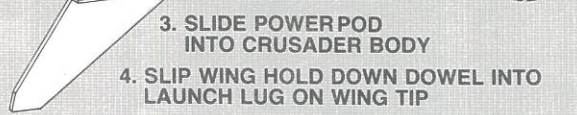

## 5. SLIDE ELEVATOR HOLD DOWNS OVER ELEVATORS TO HOLD THEM IN HORIZONTAL POSITION

# PREPARE ENGINE

## SEPARATE THE IGNITERS

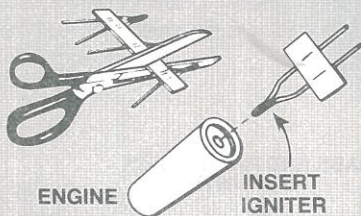

IGNITER TIP MUST TOUCH PROPELLANT DEEP INSIDE NOZZLE OPENING

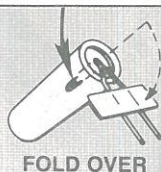

APPLY AND FIRMLY PRESS MASKING TAPE IN PLACE

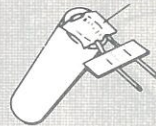

INSTALL ENGINE IN ROCKET

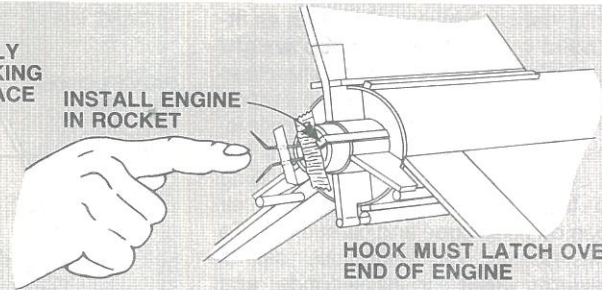

HOOK MUST LATCH OVER END OF ENGINE

# LAUNCH SUPPLIES

To launch your Crusader you will need the following items:

- An Estes model rocket launching system
- Recommended Engines: B4-2, B6-2, C6-3

Use B4-2 engine for your first flight to become familiar with your Crusader's flight pattern.

# FLYING YOUR CRUSADER

Choose a large field away from power lines, tall trees, and low flying aircraft. Try to find a field at least 250 feet square. The larger the launch area, the better your chance of recovering your glider. Football fields and playgrounds are great.

Launch area must be free of dry weeds and brown grass.

Launch only during calm weather with little or no wind and good visibility.

Observe glide carefully. If Crusader dives slightly, lightly sand elevator stops to increase elevator movement. If Crusader stalls, add shims on elevator stops for less elevator movement. To make Crusader turn, add shim under one elevator stop only.

1. Be sure wing is at right angle to fuselage when in glide configuration.
2. Check for warps.
3. Make sure wing snaps into glide position when pod releases. If wing pivot binds or does not snap open, replace rubber band, or use a silicone spray lubricant to lubricate pivot.

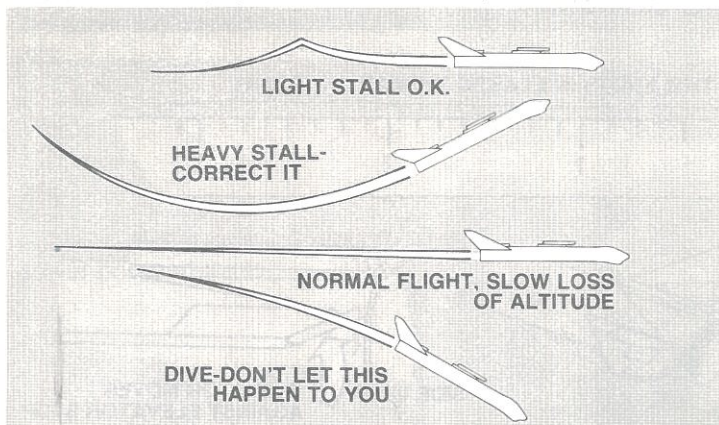

# MISFIRES

Failure of the rocket engine to function properly is nearly always caused by a failure to install the igniter correctly. This failure permits the igniter to heat and burn into two pieces without igniting the engine.

# FOR YOUR SAFETY AND ENJOYMENT

Always follow the NAR-HIA\* MODEL ROCKETRY SAFETY CODE while participating in any model rocketry activities.

\*National Association of Rocketry—The Hobby Industry of America

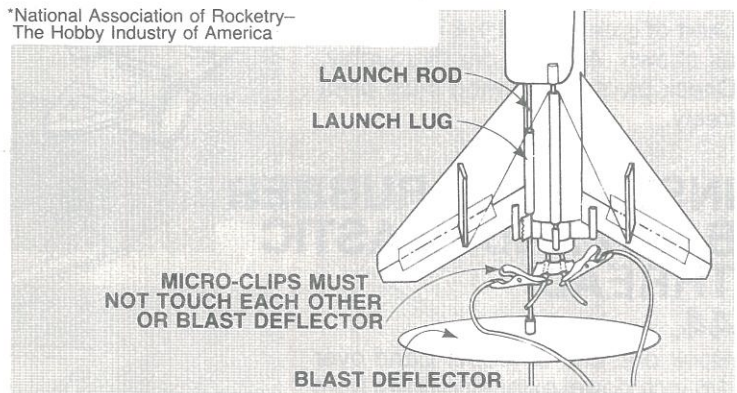

# COUNTDOWN AND LAUNCH

- 5 REMOVE SAFETY KEY to disarm the launch controller.
- 4 Remove safety cap and slide launch lugs over launch rod to place rocket on launch pad. Make sure the rocket slides freely on the launch rod.
- 3 Attach micro-clips to the igniter wires. Arrange the clips so they do not touch each other or the metal blast deflector. Attach clips as close to protective tape on igniter as possible.
- 2 Move back from your rocket as far as launch wire will permit, (at least 15 feet).
- 1 INSERT SAFETY KEY to arm the launch controller.

# LAUNCH!!!

PUSH AND HOLD LAUNCH BUTTON UNTIL ENGINE IGNITES  
Remove safety key—Replace cap on rod.

# CONSTRUCTION NOTES