



INTERCEPTOR II

#1973

A DAMON COMPANY

ESTES INDUSTRIES
1295 H STREET
PENROSE, COLORADO 81240 USA

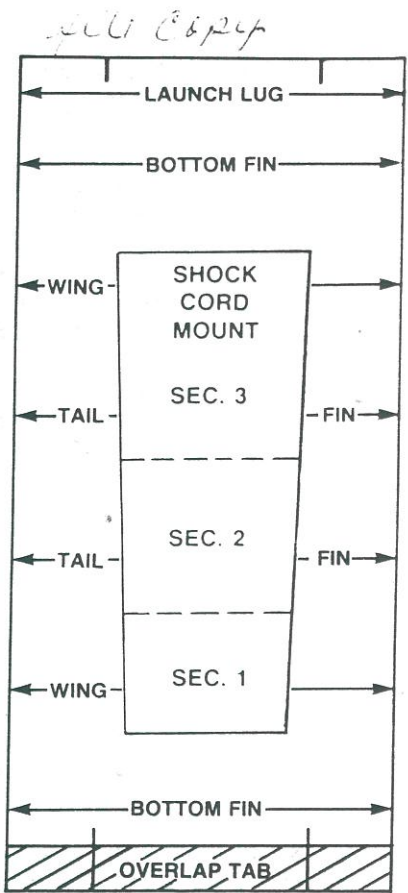
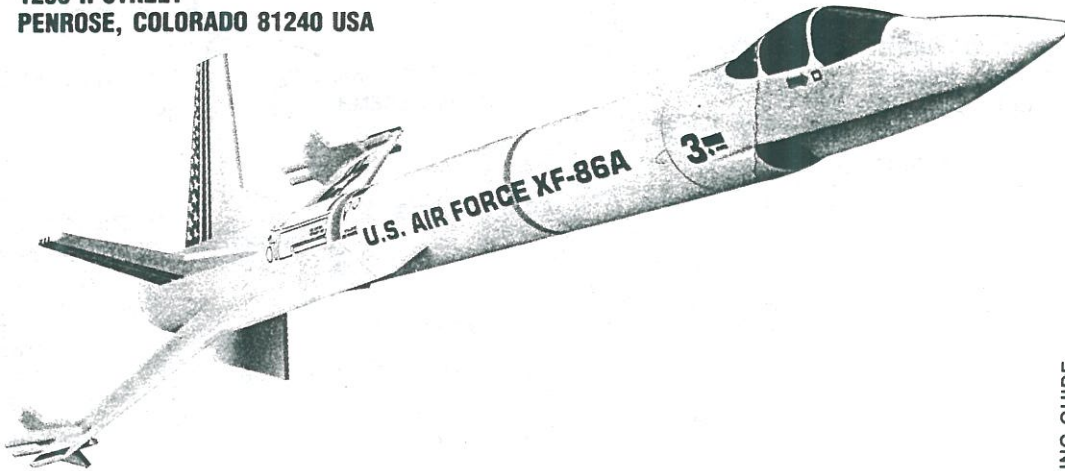

PARTS AND SUPPLIES

Locate the parts shown below and lay them out on the table in front of you. In addition to the parts included in the kit you will also need:



ASSEMBLY TIP

Read all instructions before beginning work on your model. Make sure you have all parts and supplies. Test-fit all parts together before applying any glue. If any parts don't fit properly, sand as required for precision assembly.

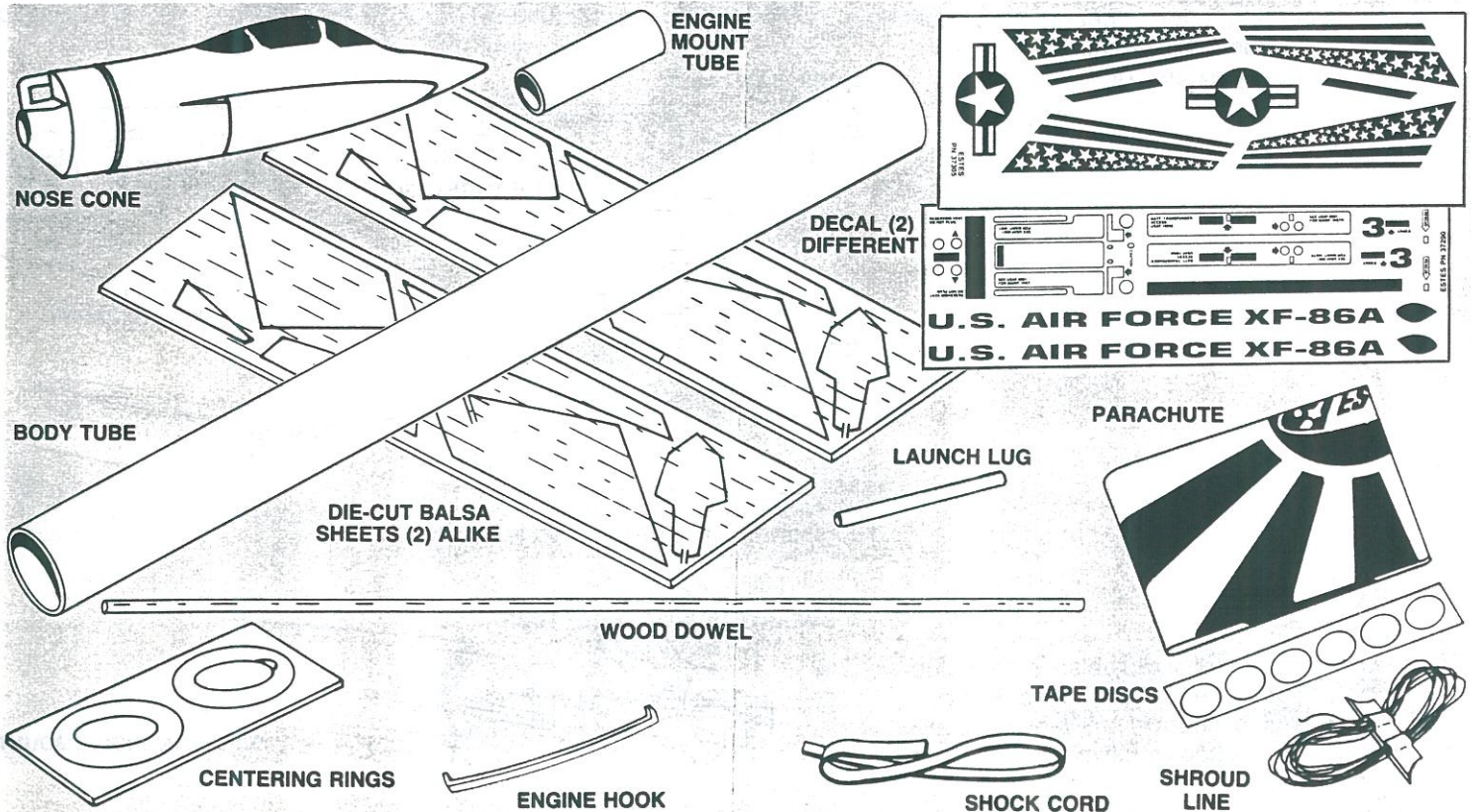

ROCKET ASSEMBLY

- Mark engine mount tube 1 inch and 2½ inches from one end.
- Cut 1/8 inch long slit at 2½ inch mark.
- Insert one end of engine hook into slit.
- Wrap masking tape around assembly twice at 1 inch mark.
- Slide slotted adapter ring onto rear of tube and up to masking tape. Slot fits over engine hook. Glue both sides of ring/tube joint.
- Slide remaining ring over front of tube and down to end of engine hook. Glue both sides of ring/tube joint.

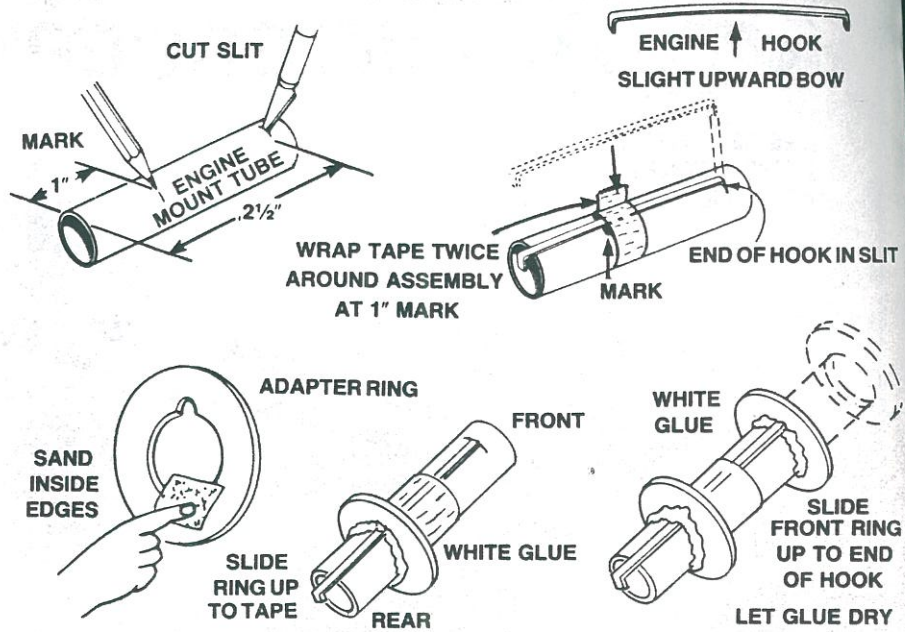

2

- Fine sand balsa die-cut sheets. Carefully remove fins by freeing edges with sharp knife.
- Stack alike fins together. Sand all edges smooth.

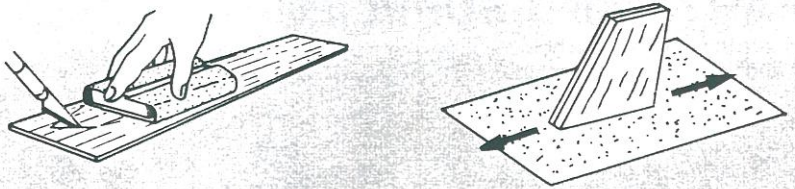

3

- Sort and identify the parts.
- Remove wood from slots in wings and wing fins.
- Assemble wings and tail fins over a piece of waxed paper, on a flat surface.
- Apply glue to edge of part to be joined. Press parts together. Use a ruler to make sure bottom edges of parts are straight. If not, adjust parts to make edge straight.
- Wipe away excess glue and let dry.

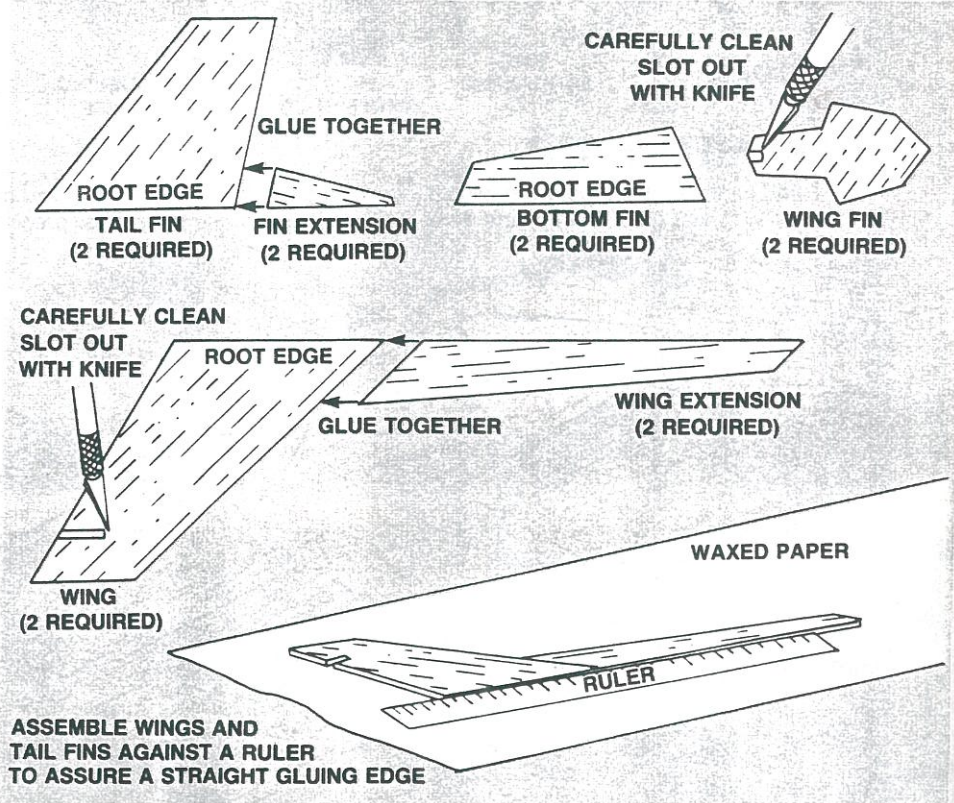

4

- Using a piece of scrap balsa, smear glue inside body tube 2 inches from one end.
- Push engine mount in until tube ends are even. Engine hook must extend from end of body tube.

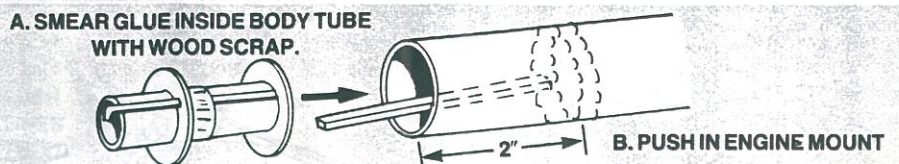

5

- Cut out tube marking guide from front of instructions.
- Wrap guide around the tube and tape. Mark tube at arrows. Remove guide and save.

MARK TUBE AT ARROWS

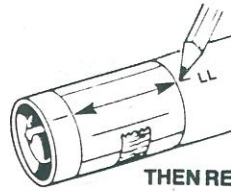

LINE UP LAUNCH LUG LINE WITH ENGINE HOOK

THEN REMOVE MARKING GUIDE

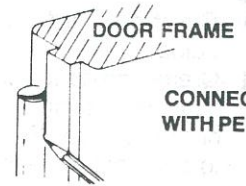

CONNECT MARKS WITH PENCIL LINE

EXTEND ALL LINES

6

- Cut four 4½ inch long pieces from 18 inch long wood dowel.
- Apply glue to slots in wings and slide wing fins into place. Wipe excess glue from joints.
- Apply glue to each wood dowel at contact points of wing and fin. Position each dowel against wing fin and even with leading edge of wing. Attach two dowels per wing as shown.

ACTUAL SIZE

CUT WOOD DOWEL INTO 4 EQUAL PIECES, EACH THIS LENGTH.

GLUE WING FIN TO WING

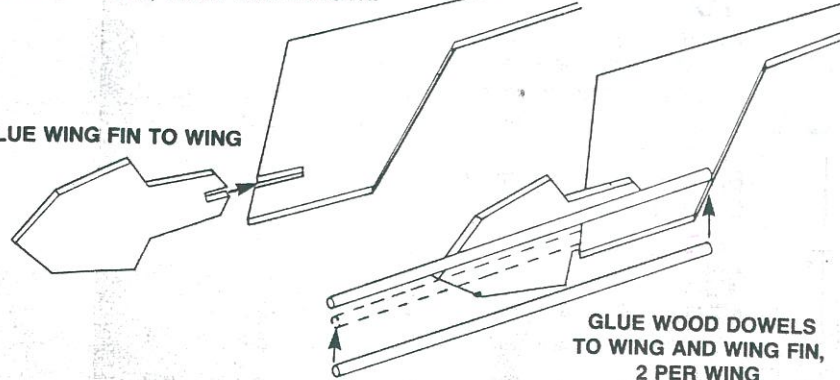

GLUE WOOD DOWELS TO WING AND WING FIN, 2 PER WING

7

- Position tail fins on their alignment lines 1 inch from end of body tube. Let each dry several minutes before applying the next one.
- Position wings on their alignment lines 3 inches from end of body tube. Let dry before applying next one.
- Adjust fins and wings to project straight out from tube.
- Glue bottom fins to body on their alignment lines 1 inch from end of body tube. Adjust fins to project straight out from body tube. Let dry.
- Do not set rocket on fins or wings while glue is wet.

FINS MUST BE ATTACHED CORRECTLY FOR STABLE FLIGHT!

GLUE TAIL FINS TO ALIGNMENT LINES 1" FROM END OF TUBE

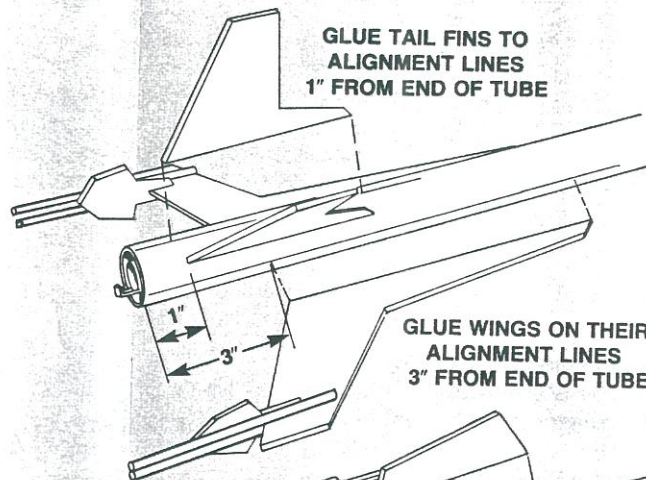

GLUE WINGS ON THEIR ALIGNMENT LINES 3" FROM END OF TUBE

GLUE BOTTOM FINS CENTERED ON ALIGNMENT LINES 1" FROM END OF TUBE

8

- Glue launch lug to rocket body on alignment line 6¾ inches from rear end of body tube.

LAUNCH LUG

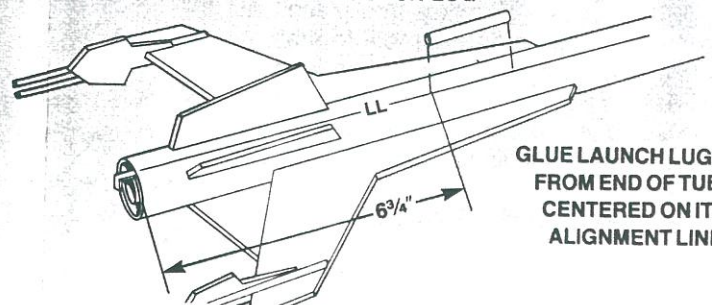

GLUE LAUNCH LUG 6¾" FROM END OF TUBE, CENTERED ON ITS ALIGNMENT LINE

9

- Cut shock cord mount from tube marking guide.
- Crease on dotted lines by folding. Spread glue on section 1 and lay end of shock cord into glue. Fold over and apply glue to back of first section and exposed part of section 2. Lay shock cord as shown, and fold mount over again.
- Clamp unit together with fingers until glue sets.

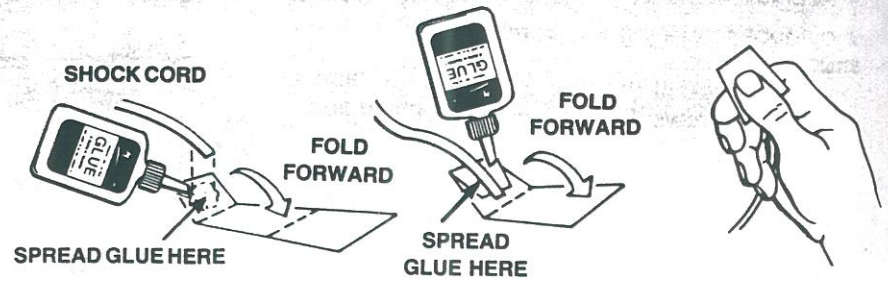

10

- Apply glue to inside front of large body tube to cover an area no less than 1 inch to 2 inches from end. The glued area should be same size as shock cord mount.
- Press mount firmly into glue as shown.
- Hold until glue sets.

SPREAD GLUE INSIDE BODY TUBE

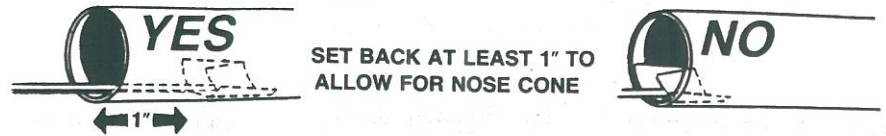

11

- Apply a glue reinforcement to each fin/body tube joint and each side of launch lug.
- Support rocket as shown until glue dries.

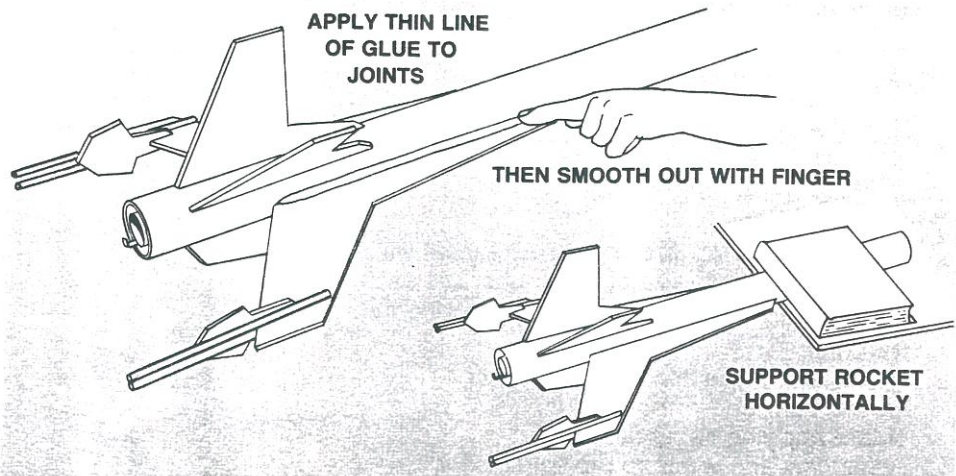

12

- Trim excess plastic from around sides of nose cone with a sharp knife. Also remove any excess plastic from inside molded eyelet.
- Wipe nose cone with damp cloth to remove oil and dirt.

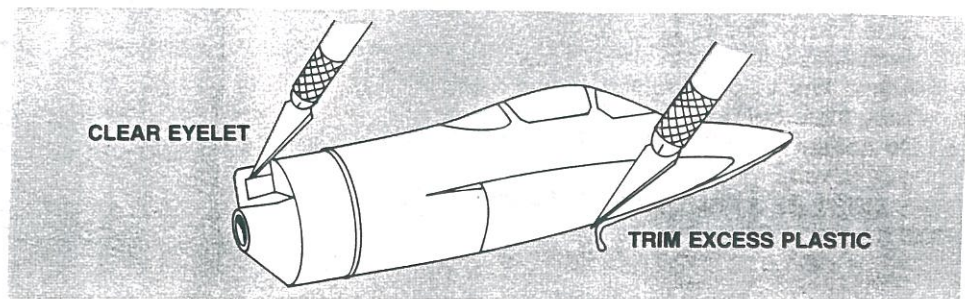

13

- Cut out parachute on edge lines.
- Cut three 36 inch lengths of shroud line.
- Form small loops with shroud line ends and press onto sticky side of tape discs.
- Attach tape discs with line ends to top of parachute as shown.
- Firmly press tape discs into place until both tape discs and parachute material are molded around shroud line loops.
- Pass shroud line loops through loop on nose cone. Pass parachute through loop ends and pull lines against the nose cone.
- Tie free end of shock cord to nose cone eyelet.

