



A DAMON COMPANY

Estes Industries
1295 H Street
Penrose, CO 81240

GEMINI TITAN

#1978

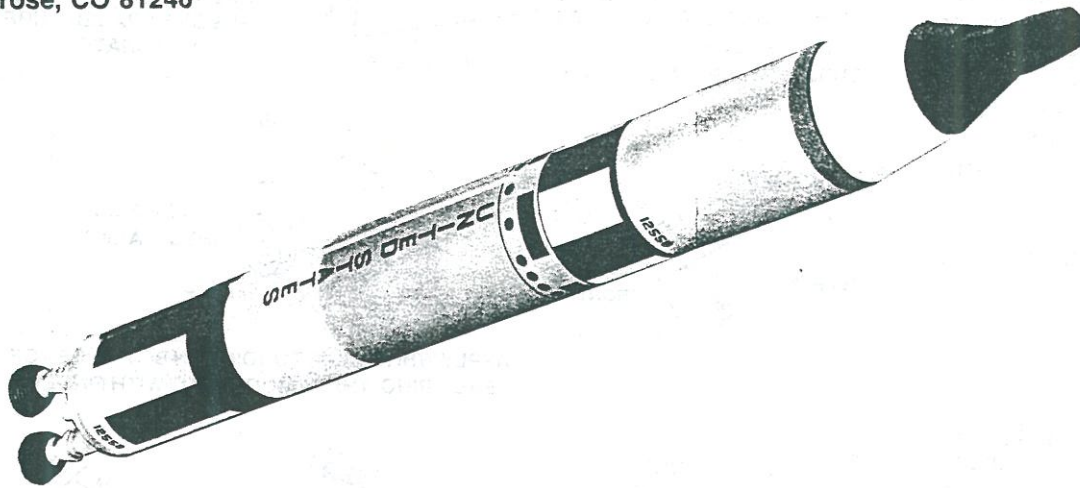
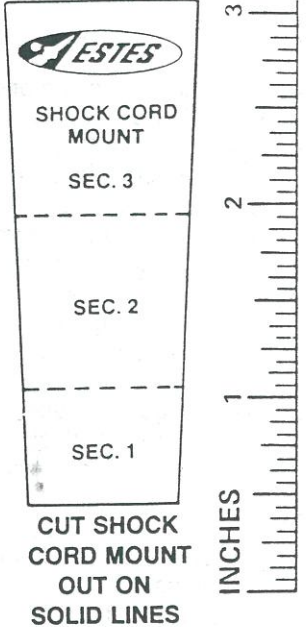

PARTS AND SUPPLIES

Locate the parts shown below and lay them out on the table in front of you. In addition to the parts included in the kit you will also need:

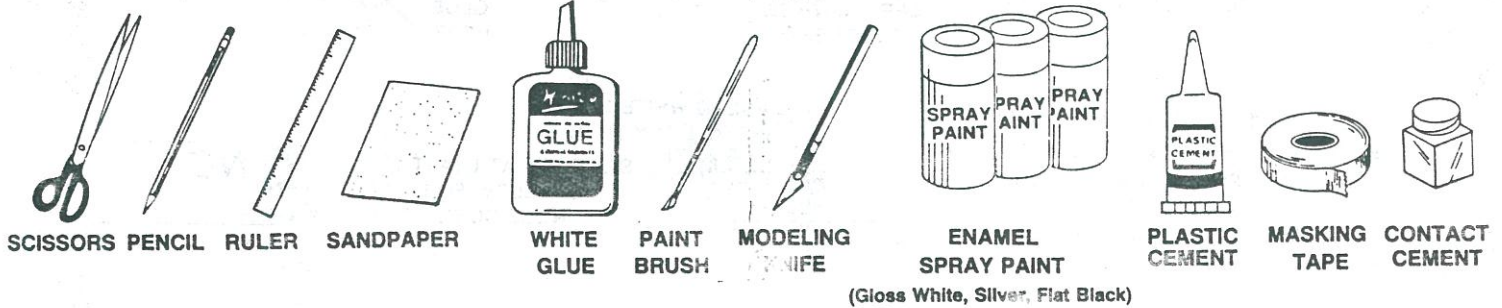

ASSEMBLY TIP

Read all instructions before beginning work on your model. Make sure you have all parts and supplies. Test-fit all parts together before applying any glue. If any parts don't fit properly, sand as required for precision assembly.

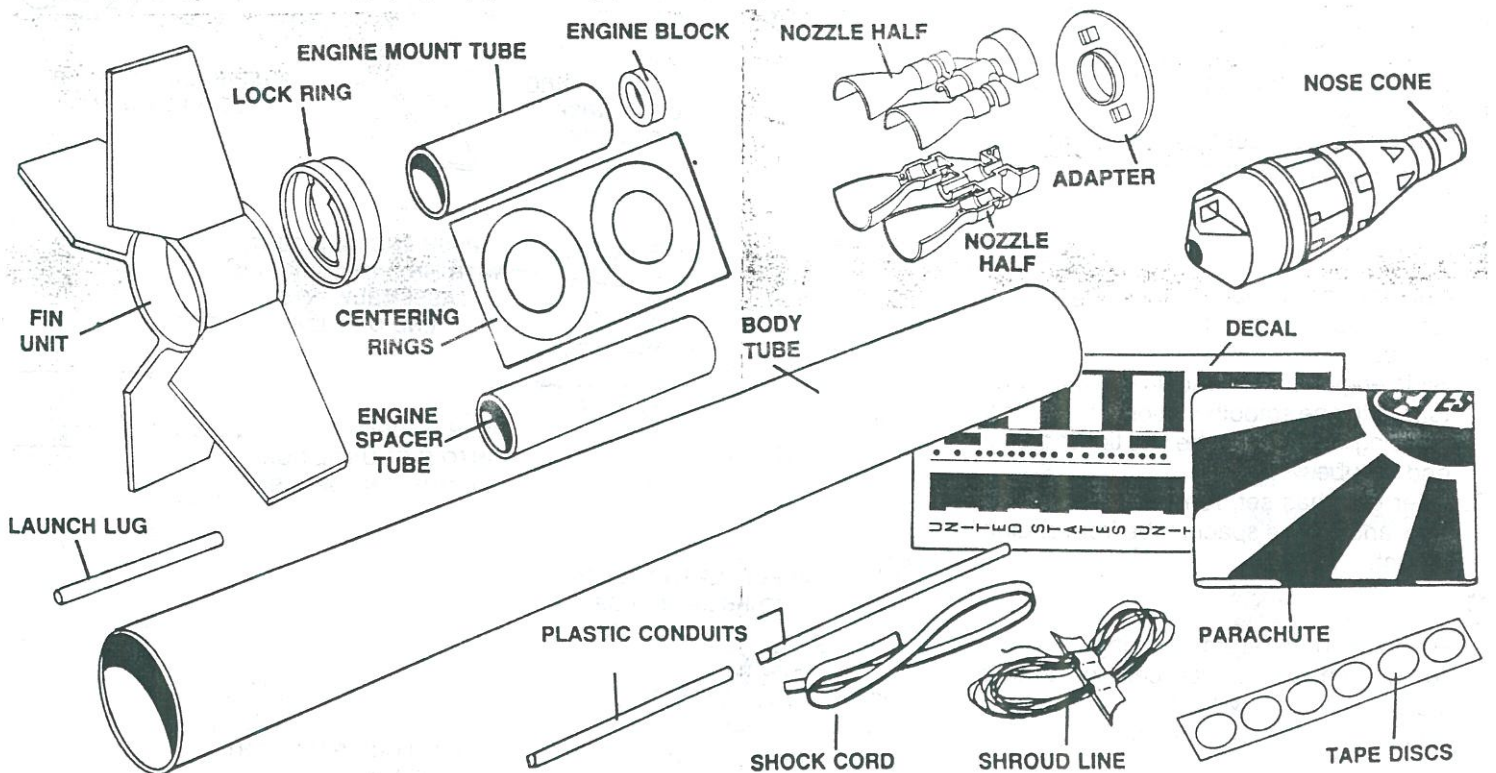

1

- A. Apply glue to inside of one end of engine mount tube.
- B. Insert engine block into opposite end of tube and push engine block up even with end of tube. Use yellow engine spacer tube to do this. Immediately remove spacer tube before glue sets.
- C. Mark engine mount tube 1/4 and 1 3/4 inches from engine block end of tube.
- D. Remove centering rings from die-cut card.
- E. Slide rings onto tube, one at each mark. Apply glue to both sides of each ring. Set assembly aside to dry.

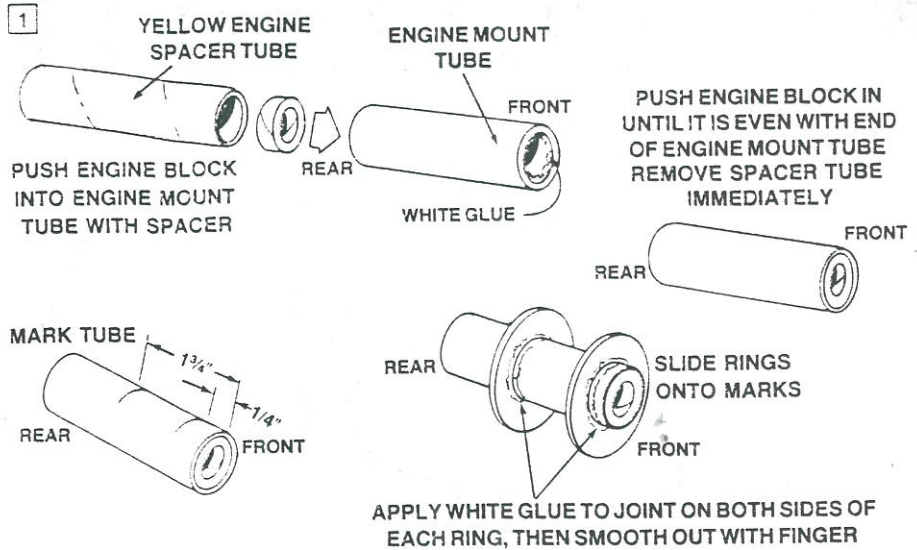

2

- A. Cut shock cord mount from front of instructions.
- B. Crease on dotted lines by folding. Spread glue on section 1 and lay end of shock cord into glue. Fold over and apply glue to back of first section and exposed part of section 2. Lay shock cord as shown and fold mount over again.
- C. Clamp unit together with fingers until glue sets.



3

- A. Apply glue to inside front of body tube to cover an area no less than 1 inch to 2 inches from end. The glued area should be same size as shock cord mount.
- B. Press mount firmly into glue as shown.
- C. Hold until glue sets.

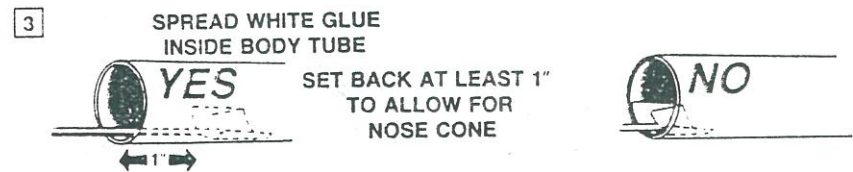

4

- A. When glue joints on engine mount are dry, test-fit engine mount into body tube. Sand centering rings if necessary to assure a smooth fit.
- B. Insert plastic fin unit into lock ring and turn to lock it into place. Do not force or overtighten.
- C. Push yellow spacer tube into fin unit and slide engine mount onto engine spacer tube.

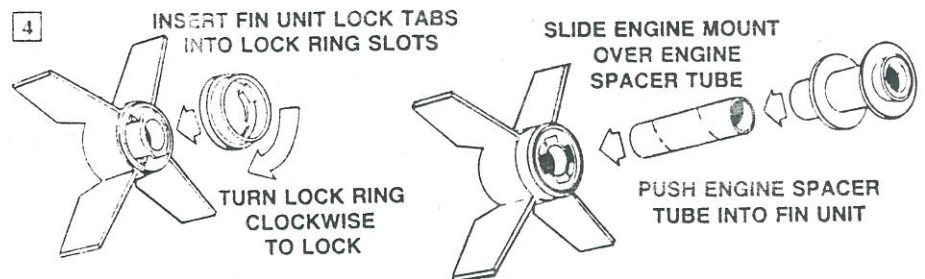

5

- A. Apply a ring of glue inside rear of body tube about 1 inch to 1 1/2 inches from end of tube.
- B. Slide engine mount and fin unit into body tube with one smooth motion until fin unit/lock ring is inside of tube and tight against end of tube.
- C. After glue has set, remove fin unit, lock ring, and engine spacer tube from engine mount.

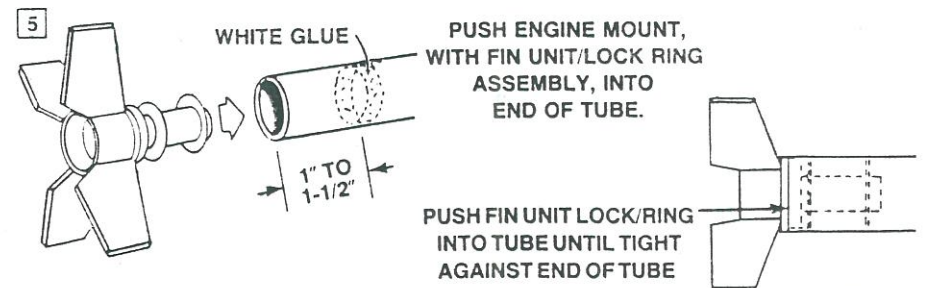

6

- A. Remove fin unit from lock ring.
- A. Apply tube-type plastic cement around inside rear of body tube.
- C. Slide lock ring into end of body tube. Twist and push it into place tight against end of tube

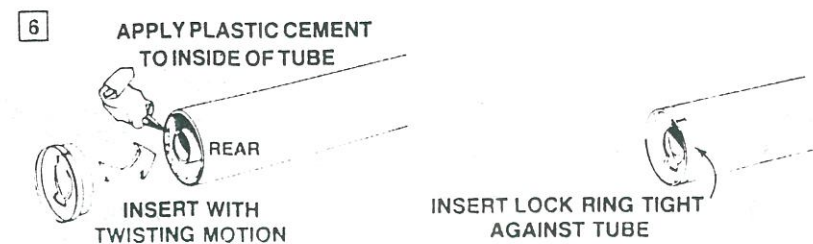

7

- A. Mark body tube 1/4 inches from raised line on side of lock ring with ruler on front of instructions.
- B. Draw straight lines down the length of the tube at the raised line and at the 1/4 inch mark. Make sure these lines are straight along tube.

7

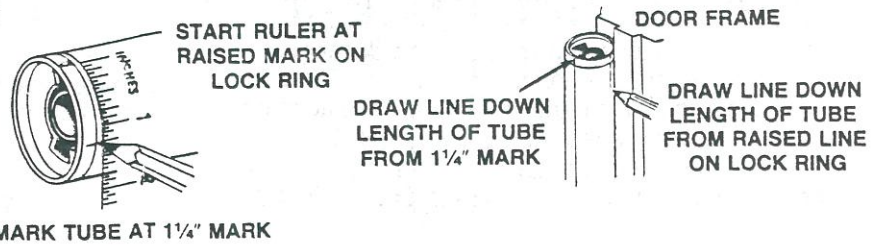

8

- A. Glue launch lug to body tube on line 4 inches from raised line on lock ring.
- B. Apply contact cement to flat sides of plastic conduits. Align them on 1/4 inch line as shown. Wipe away excess cement and set aside to dry.

8

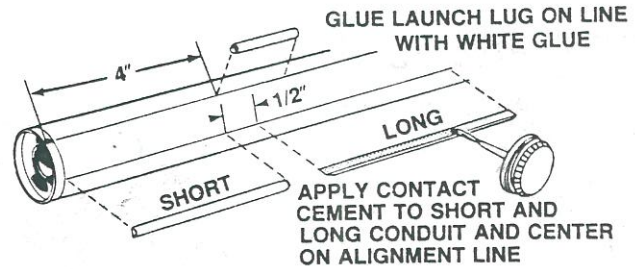

9

- A. Trim and sand excess plastic from around sides of nose cone. Remove any excess plastic from inside molded eyelet.

9

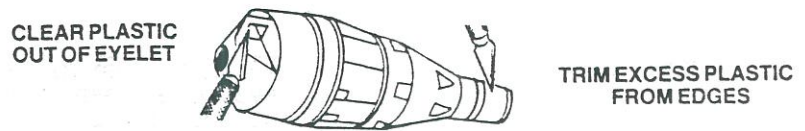

10

- A. Cut out parachute on edge lines.
- B. Cut three 23 inch lengths of shroud line.
- C. Form small loops with shroud line ends and press onto sticky side of tape discs.
- D. Attach tape discs with line ends to top of parachute as shown.
- E. Firmly press tape discs into place until both tape discs and parachute material are molded around shroud line loops.
- F. Pass shroud line loops through loop on nose cone. Pass parachute through loop ends and pull lines against the nose cone.
- G. Tie free end of shock cord to nose cone eyelet.

10

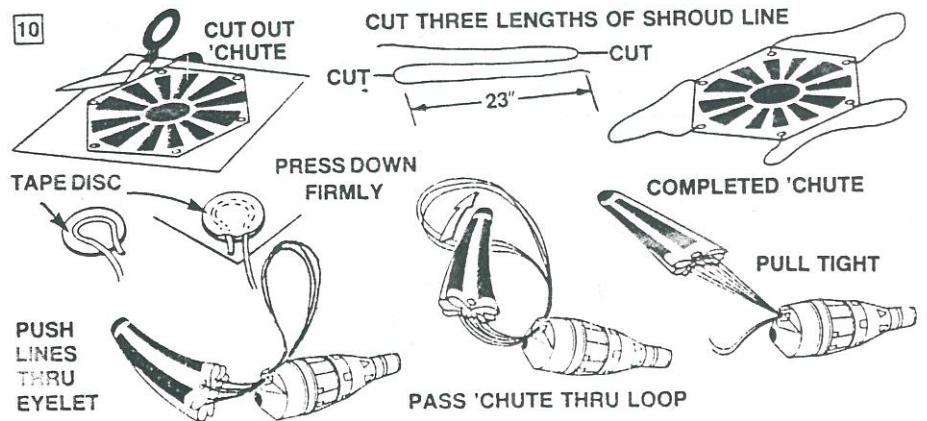

11

- A. Trim away excess plastic from plastic display nozzles.
- B. Assemble the nozzles using tube-type plastic cement. Set aside to dry.

11

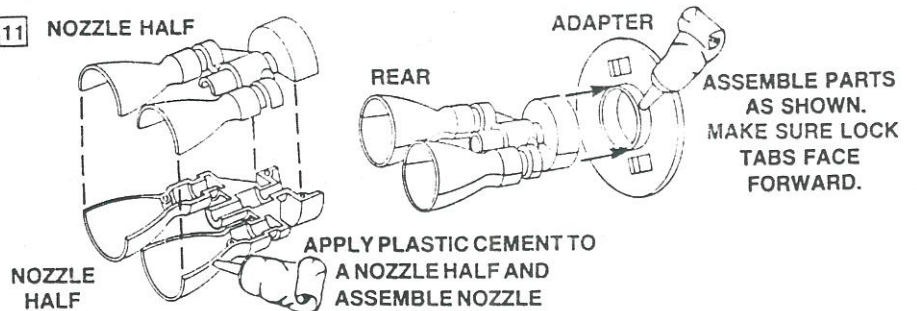

12

- A. After glue and cement are dry on model, paint entire model gloss white.
- B. When white paint is thoroughly dry, mask off areas shown and paint model silver.
- C. After all paint is thoroughly dry, mask off rocket and paint Gemini capsule part of nose cone flat black.
- D. Follow instructions on spray can for best results.

12

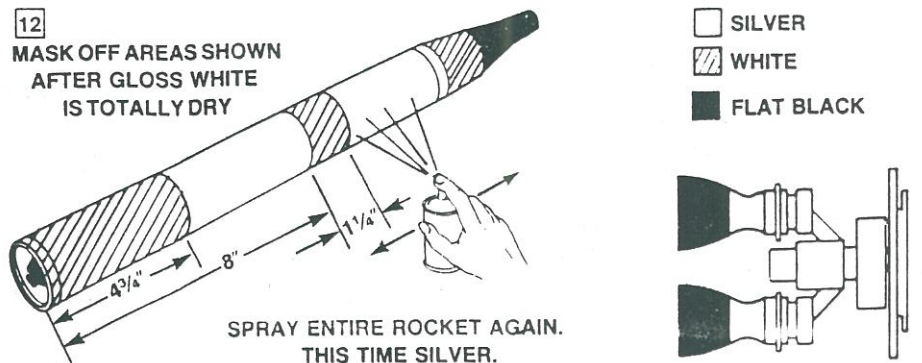

FINISHING YOUR ROCKET

Apply decals in positions shown. Cut each decal out, dip in lukewarm water for 20 seconds, and hold until it uncurls. Refer to photographs and panel front for decal placement. Slip decal off backing sheet and onto model. Blot away excess water. For best results, let decals dry overnight and apply a coat of clear spray paint to protect decals.

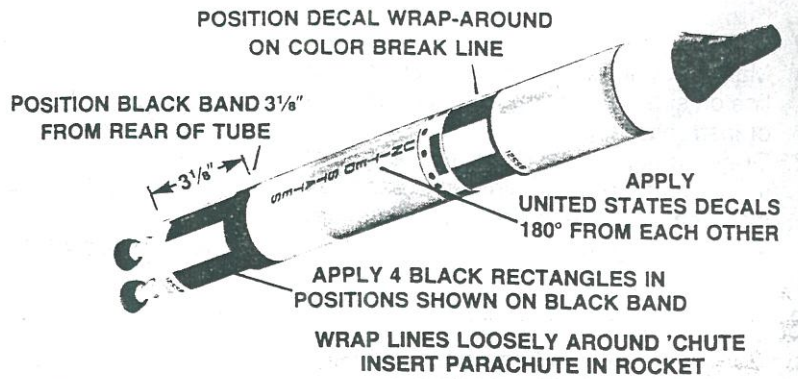

ROCKET PREFLIGHT

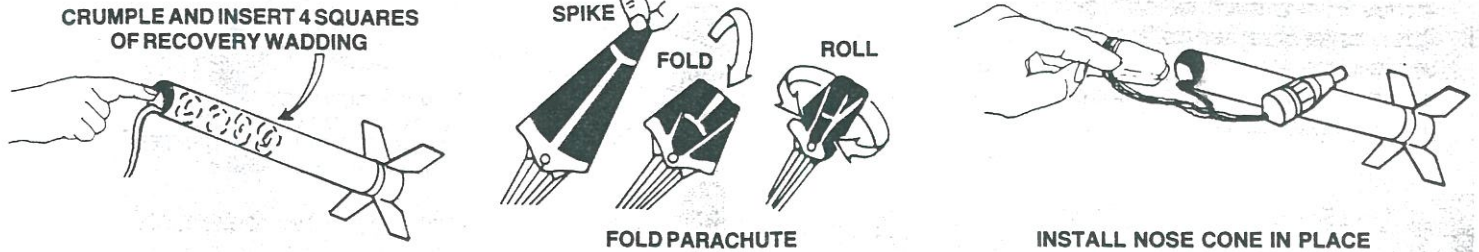

PREPARE ENGINE

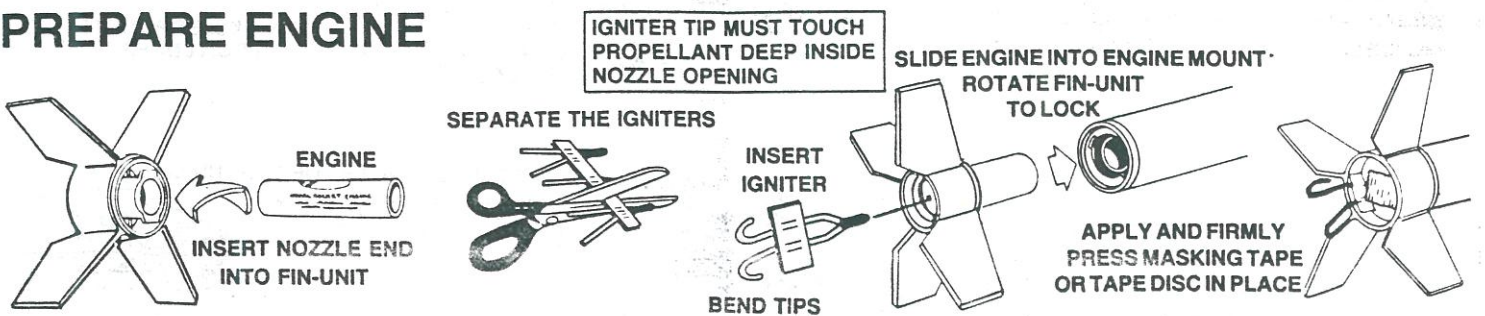

LAUNCH SUPPLIES

To launch your rocket you will need the following items:

- An Estes model rocket launching system
- Estes Parachute Recovery Wadding (No. 2274)
- Recommended Engines: A8-3, B6-4, B8-5, or C6-5

Use A8-3 engine for your first flight to become familiar with your rocket's flight pattern.

FLYING YOUR ROCKET

Choose a large field away from power lines, tall trees, and low flying aircraft. Try to find a field at least 250 feet square. The larger the launch area, the better your chance of recovering your rocket. Football fields and playgrounds are great.

Launch area must be free of dry weeds and brown grass.

Launch only during calm weather with little or no wind and good visibility.

Don't leave parachute packed more than a minute or so before launch during cold weather, colder than 40° Fahrenheit (4° Celsius).

MISFIRES

Failure of the rocket engine to function properly is nearly always caused by a failure to install the igniter correctly. This failure permits the igniter to heat and burn into two pieces without igniting the engine.

FOR YOUR SAFETY AND ENJOYMENT

Always follow the NAR-HIA* MODEL ROCKETRY SAFETY CODE while participating in any model rocketry activities.

*National Association of Rocketry-The Hobby Industry of America
page 4

COUNTDOWN AND LAUNCH

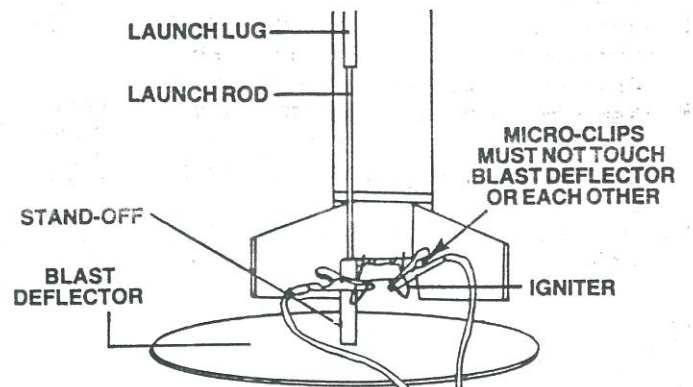

- ⑤ REMOVE SAFETY KEY to disarm the launch controller.
- ④ Remove safety cap and slide launch lug over launch rod to place rocket on launch pad. Make sure the rocket slides freely on the launch rod.
- ③ Attach micro-clips to the igniter wires. Arrange the clips so they do not touch each other or the metal blast deflector. Attach clips as close to protective tape on igniter as possible.
- ② Move back from your rocket as far as launch wire will permit (at least 15 feet).
- ① INSERT SAFETY KEY to arm the launch controller.

LAUNCH!!! PUSH AND HOLD LAUNCH BUTTON UNTIL ENGINE IGNITES

Remove safety key—Replace cap on rod.