



TM #1987

ATA MISSILE



ESTES INDUSTRIES
1295 H STREET
PENROSE, CO 81240 USA



ASSEMBLY TIP

Read all instructions before beginning work on your model. Make sure you have all parts and supplies. Test-fit all parts together before applying any glue. If any parts don't fit properly, sand as required for precision assembly.

PARTS AND SUPPLIES

Locate the parts shown below and lay them out on the table in front of you. In addition to the parts included in the kit you will also need:

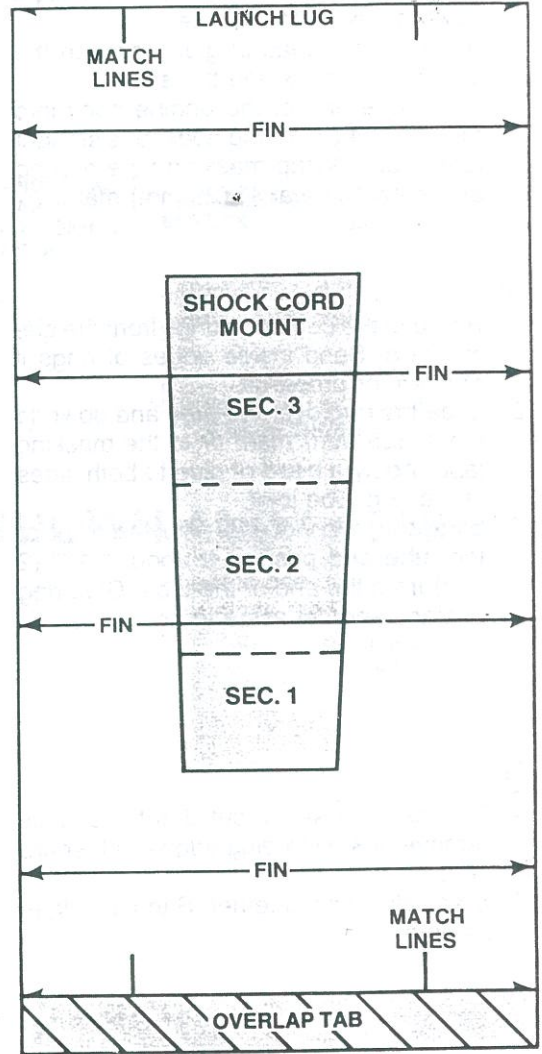
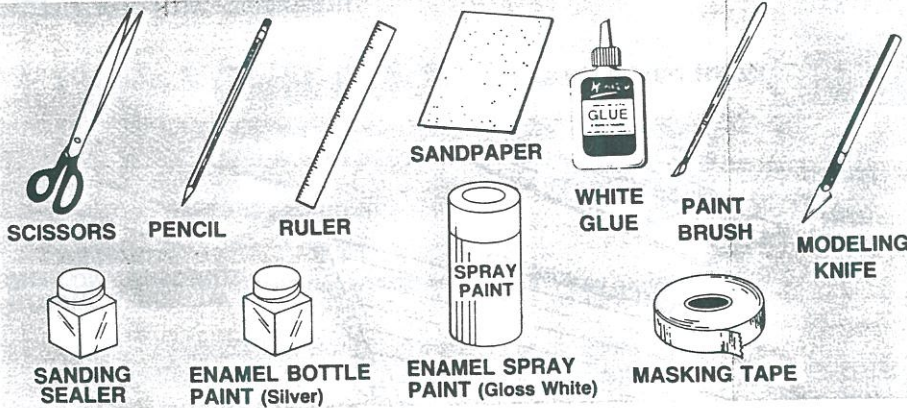

TUBE MARKING GUIDE

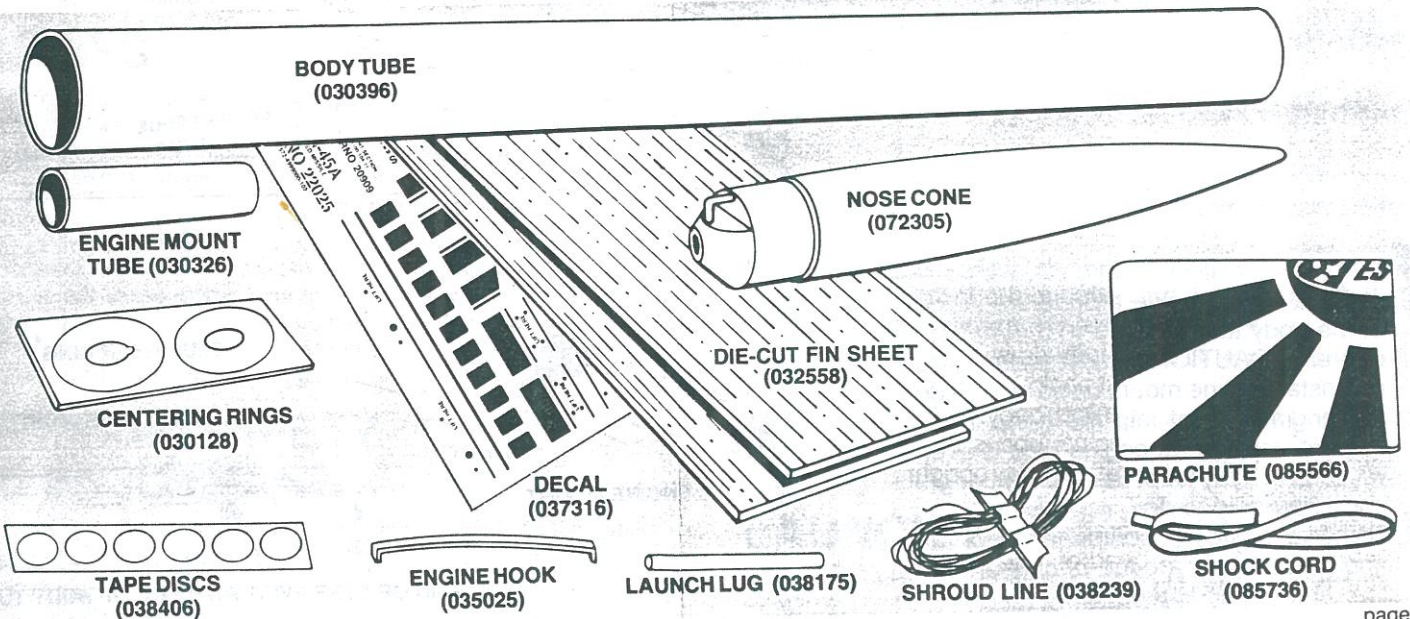

ROCKET ASSEMBLY

1

- Mark engine mount tube 1" (25 mm) and 2 1/2" (64 mm) from one end. Cut 1/8" (3 mm) long slit at 2 1/2" (64 mm) mark.
- Bend the engine hook so it has a slight upward bow in the middle.
- Apply a light bead of glue between the 1" (25 mm) mark and the slit.
- Insert one end of the engine hook into the slit. Make sure the hook runs straight along tube. Wrap masking tape around assembly twice at 1" (25 mm) mark.

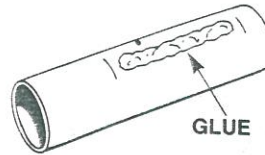
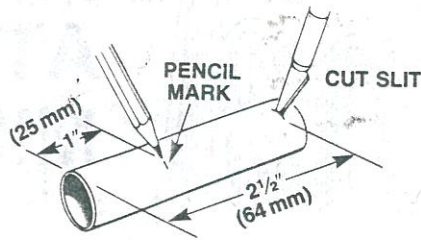

ATTACH HOOK WITH MASKING TAPE

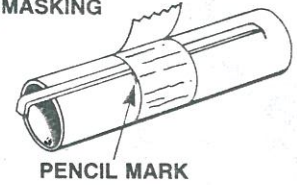

2

- Remove the centering rings from the die-cut card. Sand inside edges of rings if needed for proper fit.
- Slide the ring over the tube and down to the 1" (25 mm) mark or to the masking tape. Apply a bead of glue to both sides of the ring/tube joint.
- Slide the second ring onto the front of the tube and position it about 1/16" (2 mm) from the end of the tube. Glue ring in place and set aside to dry.

SAND INSIDE EDGES

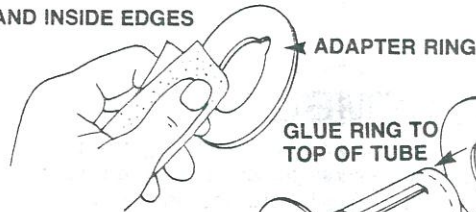

GLUE RING TO TOP OF TUBE



PENCIL MARK
GLUE RING NEXT TO MASKING TAPE

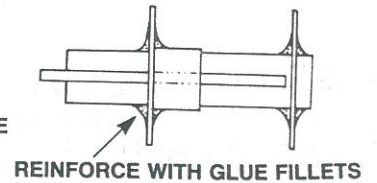

3

- Fine sand balsa die-cut sheet. Carefully remove fins by freeing edges with sharp knife.
- Stack alike fins together. Sand all edges smooth.

LIGHTLY SAND BALSAs SHEETS

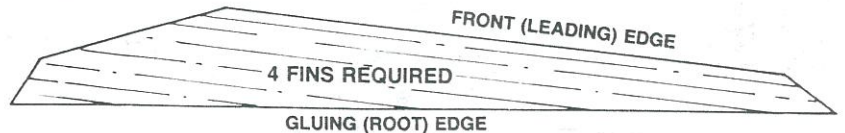
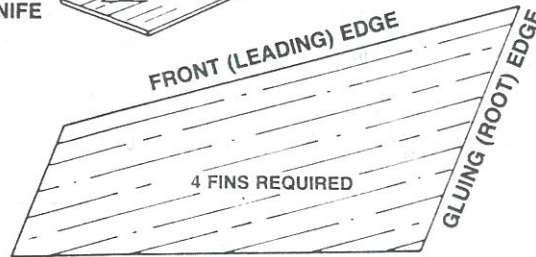
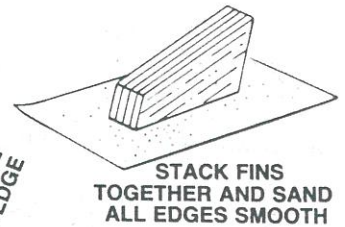

4

- Apply a bead of glue around the inside of the body tube about 3" (76 mm) from one end. CAUTION: Study drawing. Do not install engine mount backward. Slide the engine mount into the body. Push forward until end of engine tube is even with end of body tube. Stand body upright and allow glue to dry.
- Using a piece of scrap balsa for an applicator, apply a bead of glue around the rear ring/body tube joint.

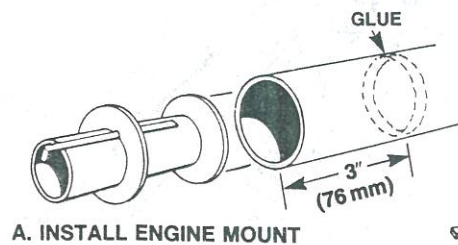

A. INSTALL ENGINE MOUNT

B. GLUE REAR RING

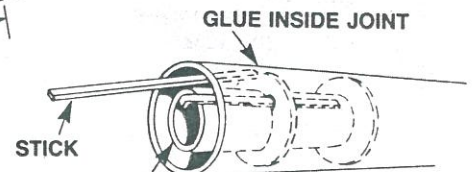

END OF TUBE EVEN WITH END OF BODY TUBE

5

- Cut out tube marking guide from front of instructions.
- Wrap guide around the tube and tape. Mark tube at arrows. Remove guide and save.
- Draw straight lines connecting each pair of marks.
- Extend lines the length of tube.

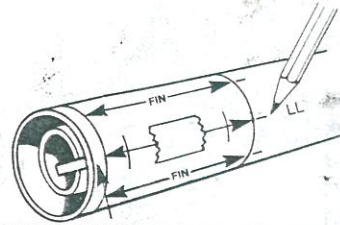

LINE UP LAUNCH LUG LINE ON GUIDE WITH ENGINE HOOK MARK TUBE AT ARROWS. THEN REMOVE GUIDE

CONNECT MARKS WITH PENCIL LINE

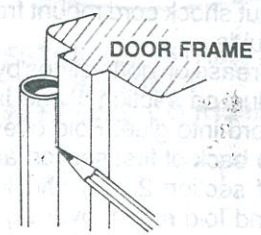

EXTEND LINES LENGTH OF TUBE

6

- Compare fins to drawings in Step 3 to find gluing (root) and front (leading) edges of fins.
- Apply a bead of glue to the root edge of a fin. Attach the fin to the body with the fin centered on a pencil line and the bottom of the fin even with the bottom of the tube. Repeat for each of other three fins.
- Adjust fins to project straight out from tube.
- Do not set rocket on fins while glue is wet.

FINS MUST BE ATTACHED CORRECTLY FOR STABLE FLIGHT!

COMPARE FINS TO DRAWING STEP 3 TO FIND GLUING OR ROOT EDGES OF FINS

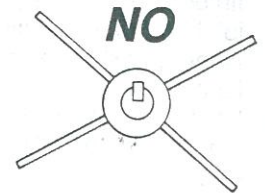
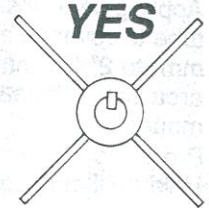
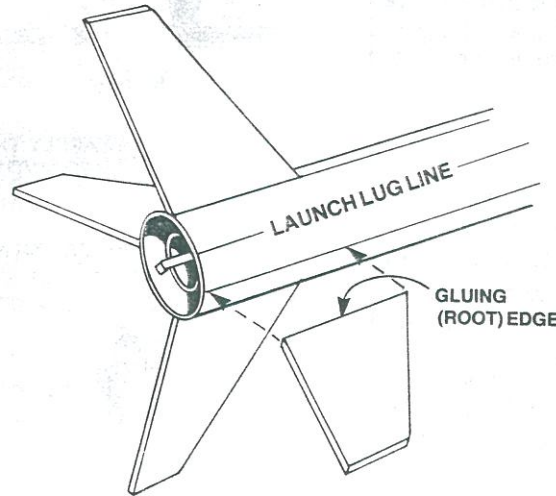

7

- Compare fins to drawings in Step 3 to find gluing (root) and front (leading) edges of top fins.
- Position and glue fins $4\frac{1}{2}$ " (114 mm) from end of tube on same alignment lines as bottom fins.
- Adjust fins to project straight out from tube and aligned with bottom fins.

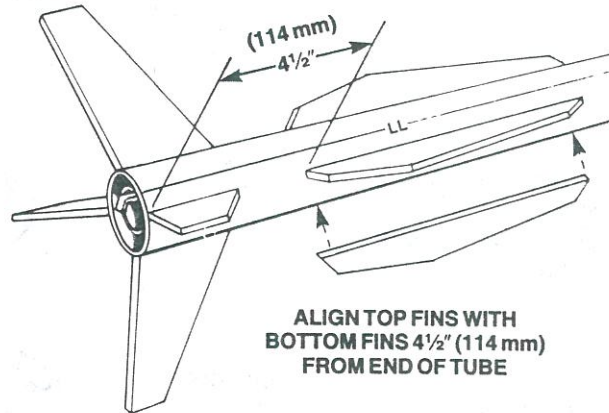

ALIGN TOP FINS WITH BOTTOM FINS $4\frac{1}{2}$ " (114 mm) FROM END OF TUBE

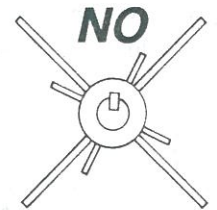
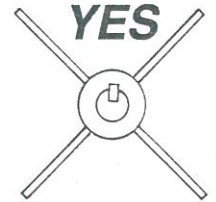

8

- Glue launch lug straight on launch lug line with its rear edge 8 " (203 mm) from rear of tube.
- Make sure launch lug runs straight along the tube.

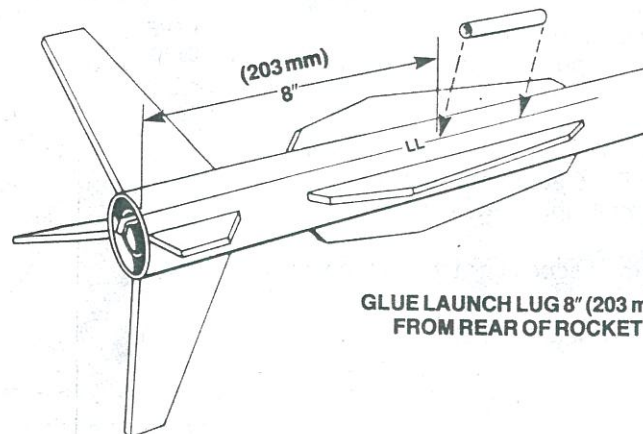

GLUE LAUNCH LUG 8 " (203 mm) FROM REAR OF ROCKET

9

- Cut shock cord mount from tube marking guide.
- Crease on dotted lines by folding. Spread glue on section 1 and lay end of shock cord into glue. Fold over and apply glue to back of first section and exposed part of section 2. Lay shock cord as shown and fold mount over again.
- Clamp unit together with fingers until glue sets.

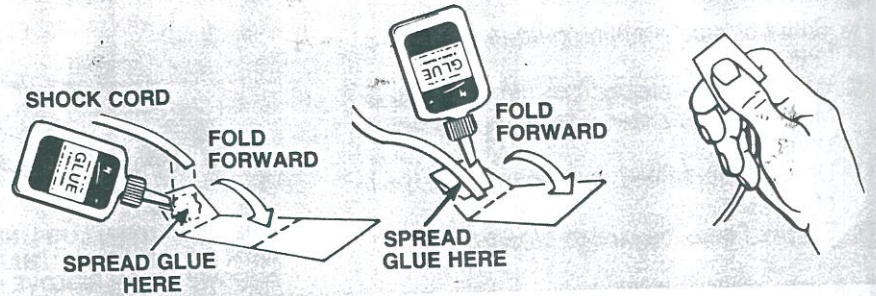

10

- Apply glue to inside front of large body tube to cover an area no less than 1" (25 mm) to 2" (51 mm) from end. The glued area should be same size as shock cord mount.
- Press mount firmly into glue as shown.
- Hold until glue sets.

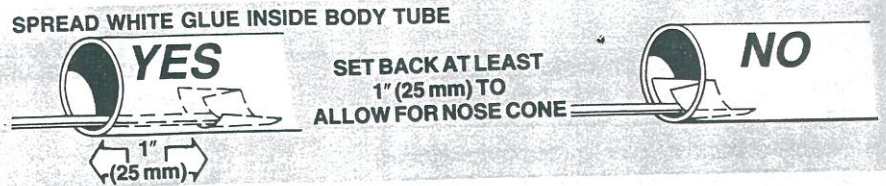

11

- Apply a bead of glue to both sides of a fin/body joint. Pull your finger along the joint to smooth the glue into an even fillet. Repeat with the remaining fins and launch lug.
- Lay the rocket down with the fins extending off the edge of the table. Place a book or other weight on the front of the body and allow glue to dry.

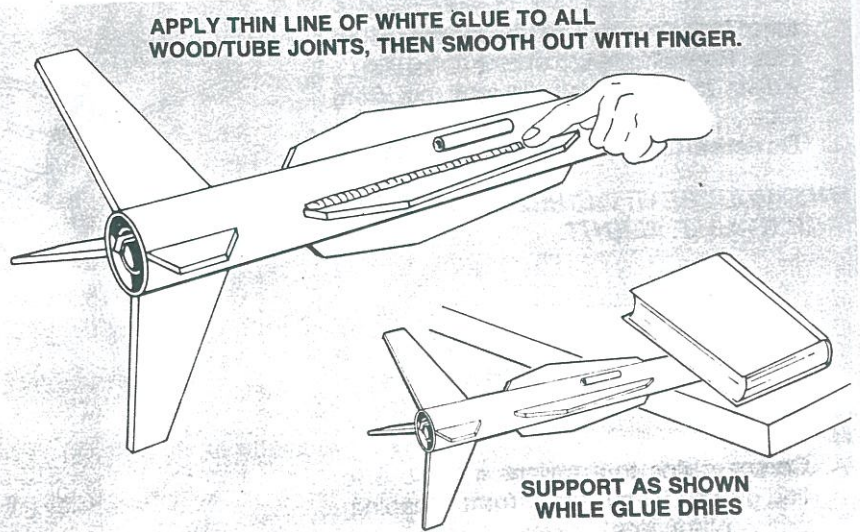

12

Trim excess plastic from the sides of the nose cone and lightly sand the seams. Wash the nose cone in warm soapy water. Allow to dry thoroughly before painting.

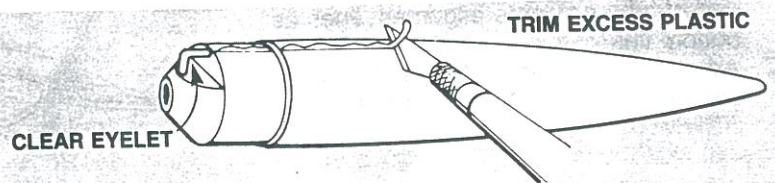

13

- Cut out parachute on edge lines.
- Cut three 23" (584 mm) lengths of shroud line.
- Form small loops with shroud line ends and press onto sticky side of tape discs.
- Attach tape discs with line ends to top of parachute as shown.
- Firmly press tape discs into place until both tape discs and parachute material are molded around shroud line loops.
- Pass shroud line loops through loop on nose cone. Pass parachute through loop ends and pull lines against the nose cone.
- Tie free end of shock cord to nose cone eyelet.

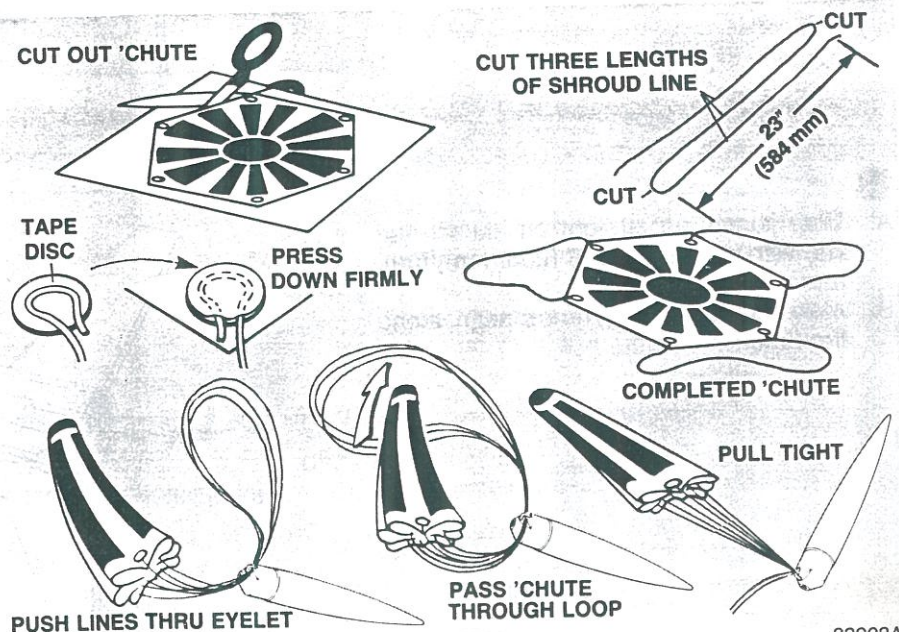

14

- A. Apply sanding sealer to all wood parts with small brush.
- B. When sealer is dry, lightly sand all sealed surfaces.
- C. Repeat sealing and sanding until wood grain is filled and smooth.

15

- A. When sanding sealer and glue are completely dry, paint model with gloss white enamel.
- B. Follow instructions on spray can for best results.
- C. Let dry overnight. Mask off rocket and paint top 1/8" (3 mm) of body tube with silver enamel.
- D. Remove mask from rocket as soon as paint has set.

FINISHING YOUR ROCKET

Apply decals in the position shown. Cut decals apart, trimming excess clear as close to details as possible. Dip one decal in lukewarm water for 20 seconds and hold until it uncurls. Slip decal off backing sheet and onto model. Move decal into exact position. Carefully blot away excess water. Smooth out any wrinkles or air bubbles with a soft cloth.

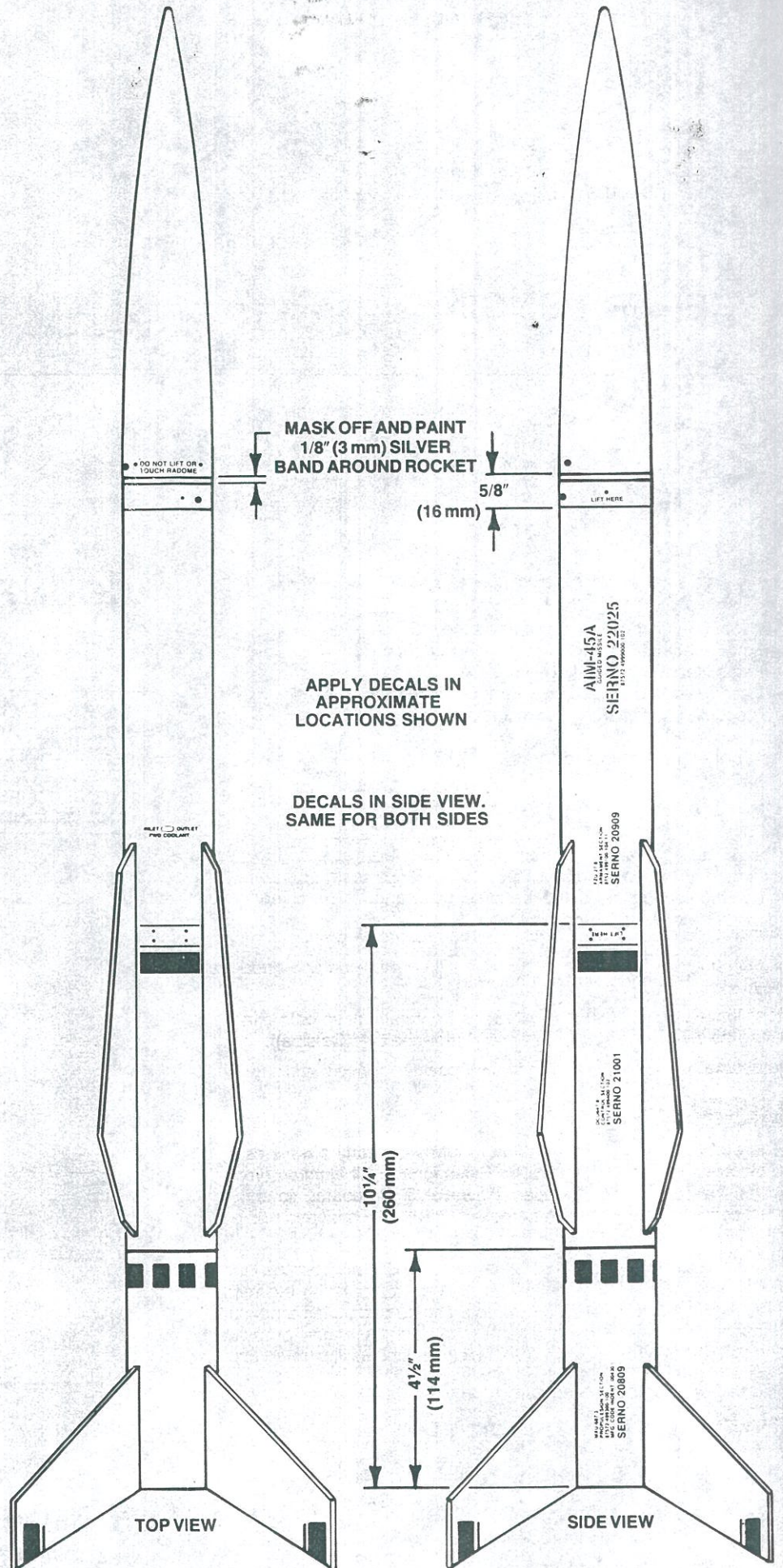

ROCKET PREFLIGHT

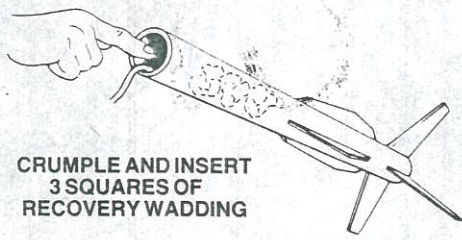

CRUMPLE AND INSERT
3 SQUARES OF
RECOVERY WADDING

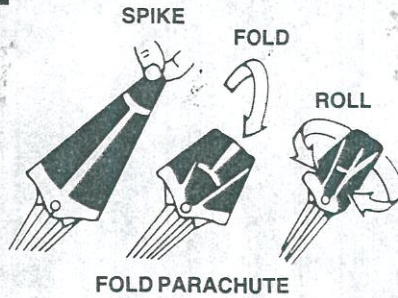

FOLD PARACHUTE

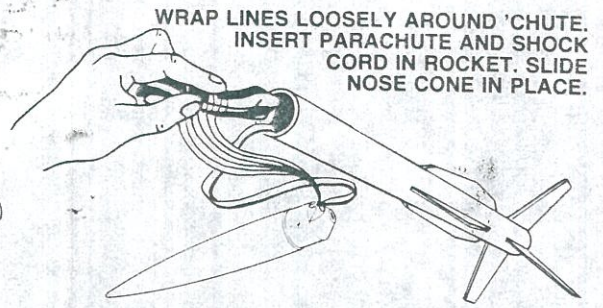

WRAP LINES LOOSELY AROUND 'CHUTE.
INSERT PARACHUTE AND SHOCK
CORD IN ROCKET. SLIDE
NOSE CONE IN PLACE.

PREPARE ENGINE

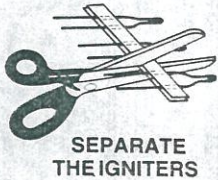

SEPARATE
THE IGNITERS

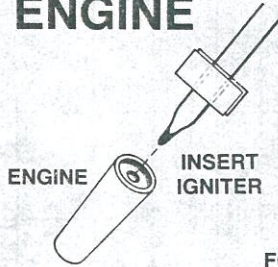

ENGINE INSERT IGNITER

IGNITER TIP MUST TOUCH
PROPELLANT DEEP INSIDE
NOZZLE OPENING

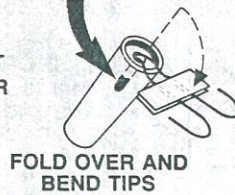

FOLD OVER AND
BEND TIPS

APPLY AND FIRMLY
PRESS TAPE
DISC OR MASKING
TAPE IN PLACE

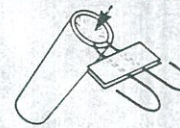

INSTALL ENGINE
IN ROCKET

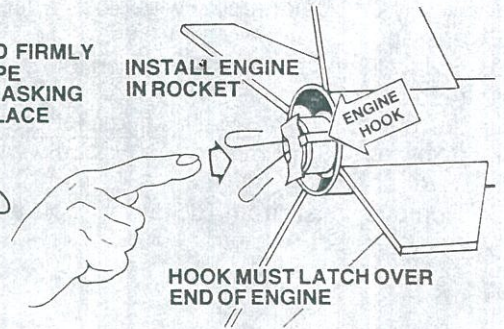

HOOK MUST LATCH OVER
END OF ENGINE

LAUNCH SUPPLIES

To launch your rocket you will need the following items:

- Estes Electrical Launch System and Launch Pad
 - Estes Recovery Wadding No. 2274
 - Recommended Estes Engines: A8-3, B4-4, B6-4, C6-3, or C6-5.
- To become familiar with your rocket's flight pattern, use a B4-4 engine for your first flight.
Use only with Estes products.

FLYING YOUR ROCKET

Choose a large field away from power lines, tall trees, and low flying aircraft. Try to find a field at least 250 feet (76 meters) square. The larger the launch area, the better your chance of recovering your rocket. Football fields and playgrounds are great.

Launch area must be free of dry weeds and brown grass.

Launch only during calm weather with little or no wind and good visibility.

Don't leave parachute packed more than a minute or so before launch during cold weather [colder than 40° Fahrenheit (4° Celsius)].

Parachute may be dusted with talcum powder to avoid sticking.

MISFIRES

Failure of the model rocket engine to ignite is nearly always caused by incorrect igniter installation. An Estes igniter will function properly even if the coated tip is chipped. However, if the coated tip is not in direct contact with the engine propellant, it will only heat and not ignite the engine.

When an ignition failure occurs, remove the safety key from the launch control system and wait one minute before approaching the rocket. Remove the expended igniter from the engine and install a new one. Be certain the coated tip is in direct contact with the engine propellant, then tape the igniter leads firmly to base of engine as illustrated above. Repeat the countdown and launch procedure.

FOR YOUR SAFETY AND ENJOYMENT

Always follow the NAR* MODEL ROCKETRY SAFETY CODE while participating in any model rocketry activities.

*National Association of Rocketry

83904A

COUNTDOWN AND LAUNCH

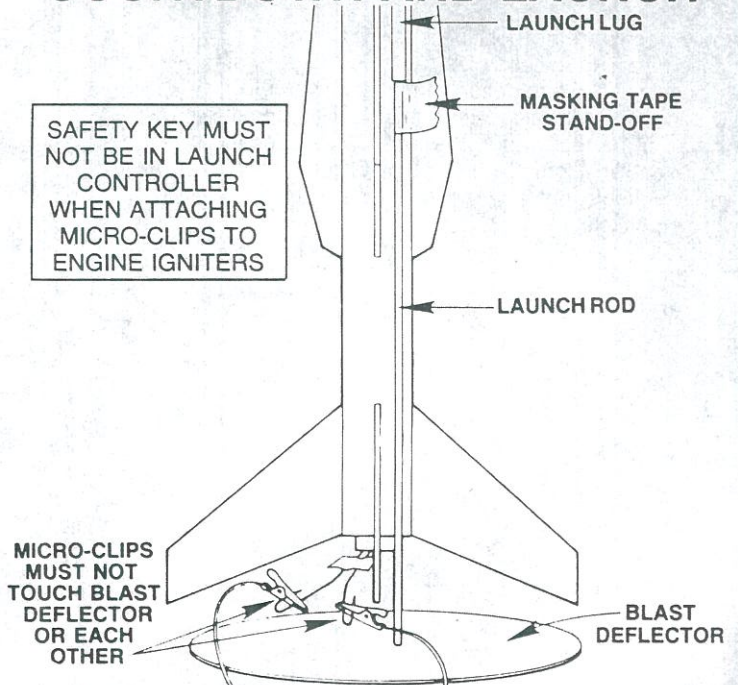

SAFETY KEY MUST NOT BE IN LAUNCH CONTROLLER WHEN ATTACHING MICRO-CLIPS TO ENGINE IGNITERS

- ⑩ BE CERTAIN SAFETY KEY IS NOT IN LAUNCH CONTROLLER.
- ⑨ Remove safety cap and slide launch lug over launch rod to place rocket on launch pad. Make sure the rocket slides freely on the launch rod.
- ⑧ Attach micro-clips to the igniter wires. Arrange the clips so they do not touch each other or the metal blast deflector. Attach clips as close to protective tape on igniter as possible.
- ⑦ Move back from your rocket as far as launch wire will permit (at least 15 feet - 5 meters).
- ⑥ INSERT SAFETY KEY to arm the launch controller.

Give audible countdown 5...4...3...2...1

LAUNCH!! PUSH AND HOLD LAUNCH BUTTON UNTIL ENGINE IGNITES

REMOVE SAFETY KEY FROM LAUNCH CONTROLLER. REPLACE SAFETY KEY AND SAFETY CAP ON LAUNCH ROD.