



ESTES INDUSTRIES
1295 H Street
Penrose, CO 81240



ALMOST READY TO FLY

82108
(12-97)
EST 2131

Mk-109 STINGRAY™

FLYING MODEL ROCKET KIT INSTRUCTIONS

TOOLS REQUIRED: SCISSORS, PENCIL, HOBBY KNIFE, SMALL PHILLIPS HEAD SCREWDRIVER, TUBE-TYPE PLASTIC CEMENT

ALL GLUED AREAS ARE SHADED IN GRAY

PARTS LAYOUT

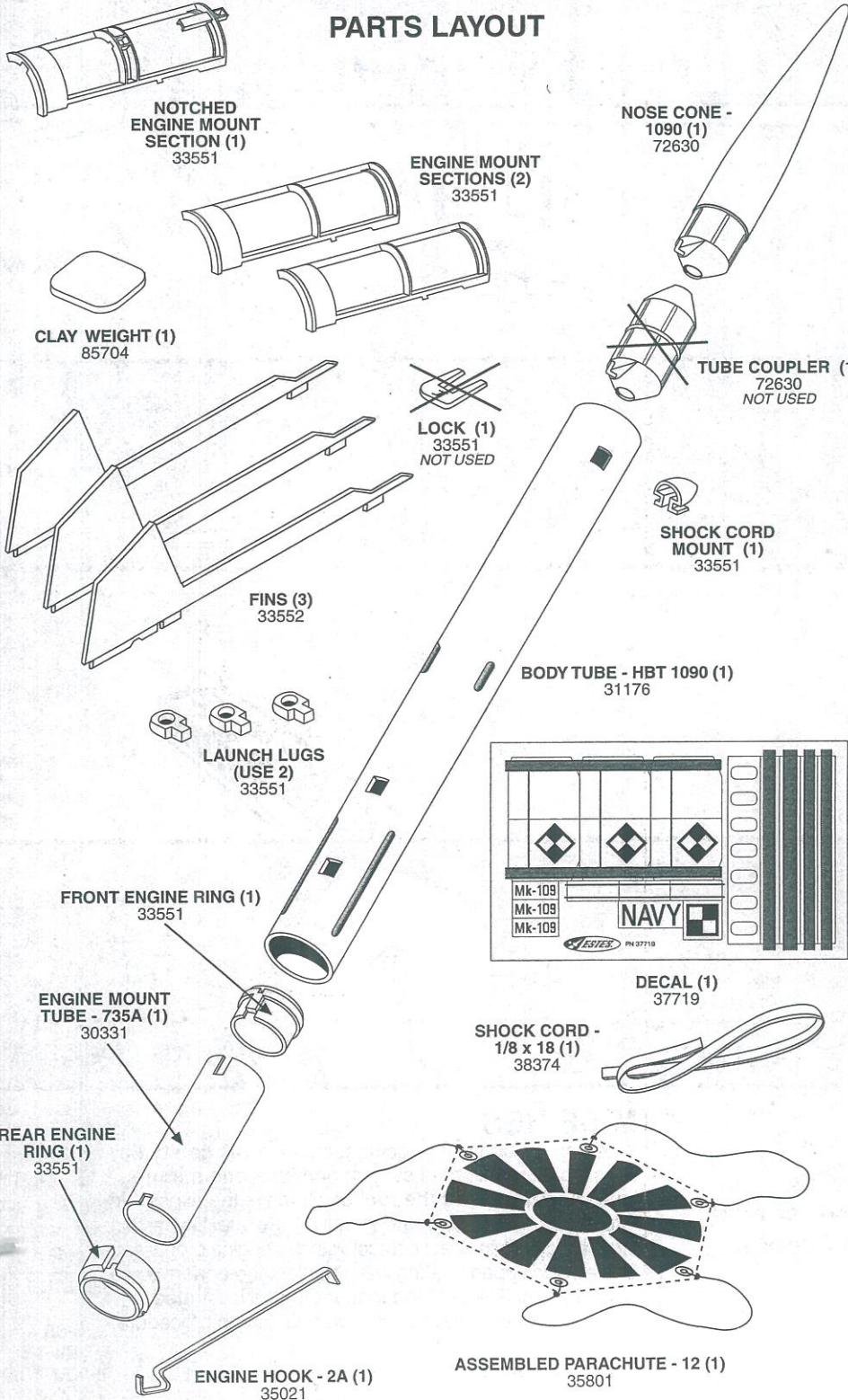

1. A. Apply plastic cement as shown to slide front engine ring inside engine mount tube. Line up with long notch.

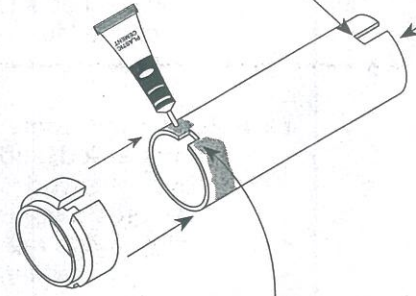

B. Slide rear engine ring over tube. Line up with short notch.

2. IMPORTANT! LINE UP LAUNCH LUG OPENINGS!

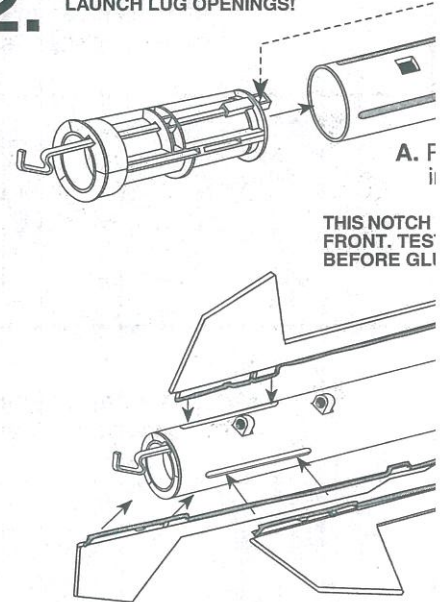

4. B. Roll clay weight "snakes", drop nose cone, and a small phillips head screwdriver press clay into cone tip.

A. Snap tube coupler off of the nose cone and discard.

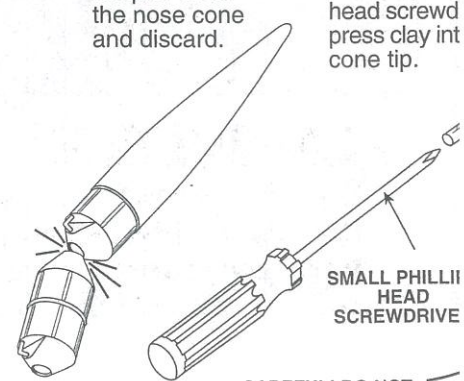

CAREFUL! DO NOT CUT OFF THIS PIECE

IMPORTANT! THIS NOTCH GOES OVER ENGINE HOOK

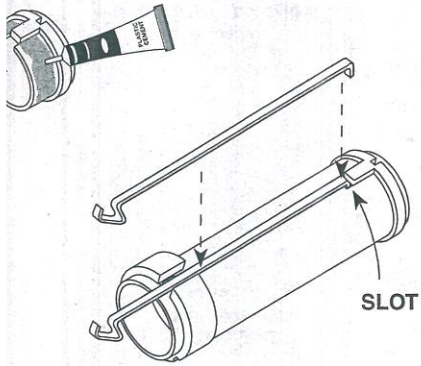

C. Attach engine hook. Push front tab through slot in tube.

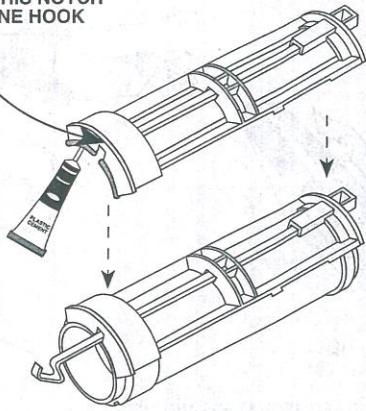

D. Apply cement to underside of notched engine mount section and attach.

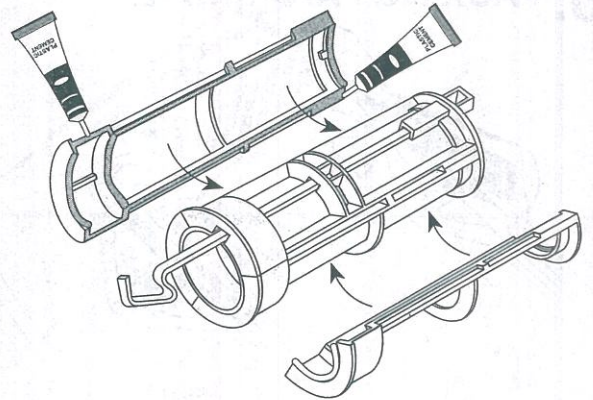

E. Now attach the remaining sections with cement as shown.

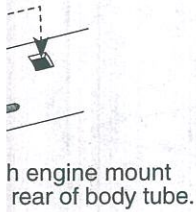

h engine mount rear of body tube.



ESTO T G.

C. Apply plastic cement along the root edges of the fins, and apply making sure each fin is seated in both slots.

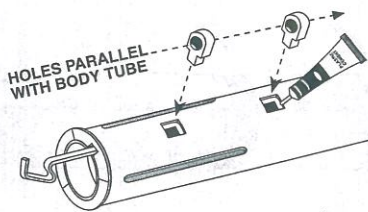

HOLES PARALLEL WITH BODY TUBE

B. Attach launch lugs with plastic cement.

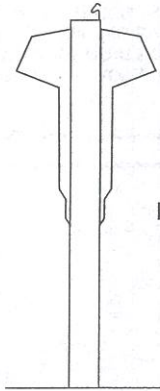

D. Set rocket on table as shown so fins will stay straight while cement sets.

3.

A. Locate elastic shock cord and shock cord mount.

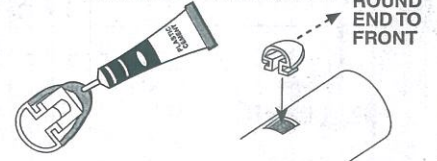

ROUND END TO FRONT

B. Apply plastic cement to the bottom of the shock cord mount as shown. Attach to body tube through square hole. Let dry.

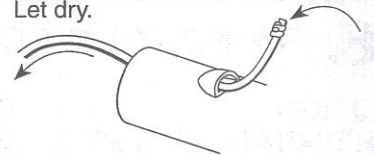

C. Tie double knot in end of shock cord. Thread other end through until knot is tight against shock cord mount.

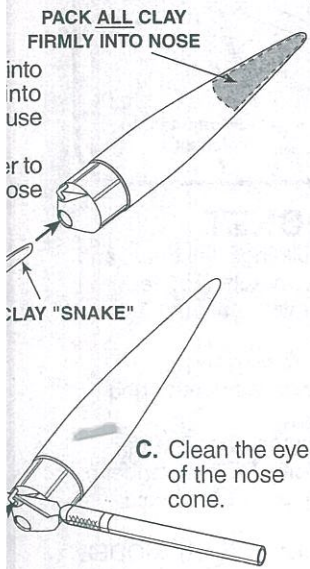

PACK ALL CLAY FIRMLY INTO NOSE

into into use er to ose

CLAY "SNAKE"

C. Clean the eye of the nose cone.

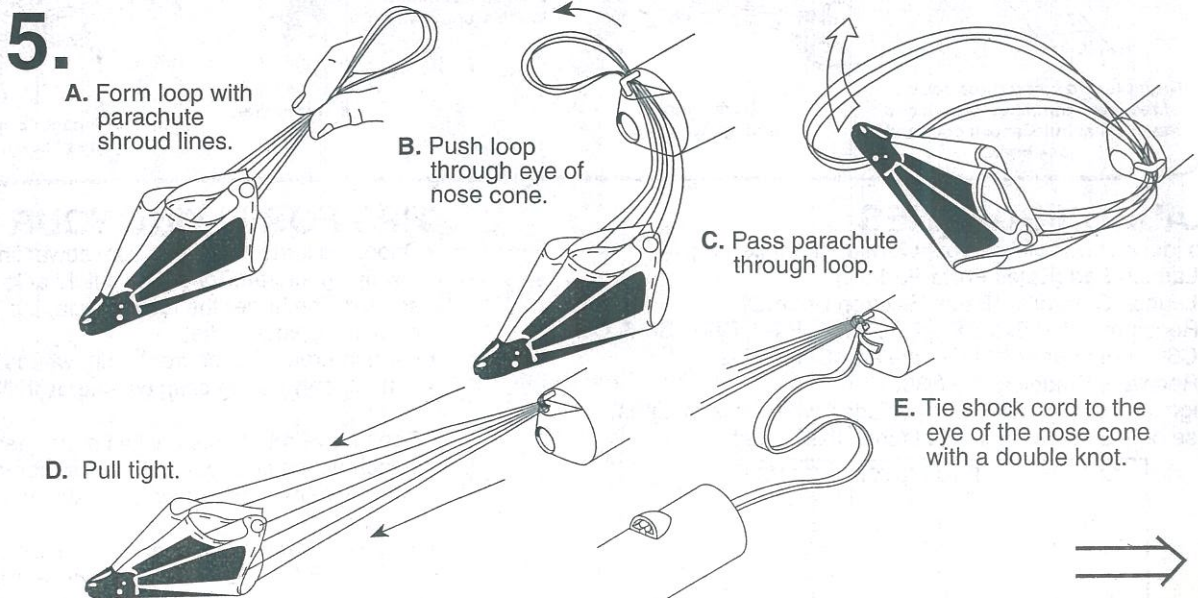

5.
A. Form loop with parachute shroud lines.

B. Push loop through eye of nose cone.

C. Pass parachute through loop.

D. Pull tight.

E. Tie shock cord to the eye of the nose cone with a double knot.



6. PACKING PARACHUTE

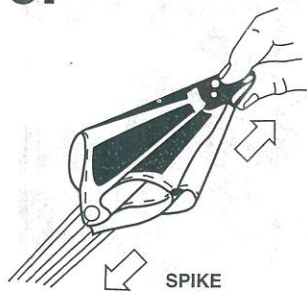

SPIKE

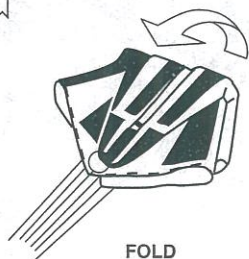

FOLD

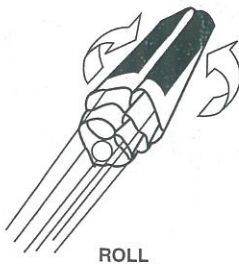

ROLL

Wrap lines loosely around chute.
Insert parachute into rocket.

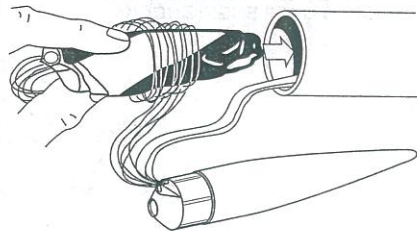

Recovery device should slide easily into body tube. If fit is too tight, unfold and repack again.

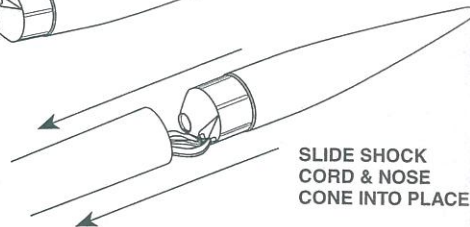

SLIDE SHOCK CORD & NOSE CONE INTO PLACE.

DO NOT FORGET TO PACK RECOVERY WADDING IN THE ROCKET BEFORE FLYING - SEE STEP 8

7. APPLYING DECALS

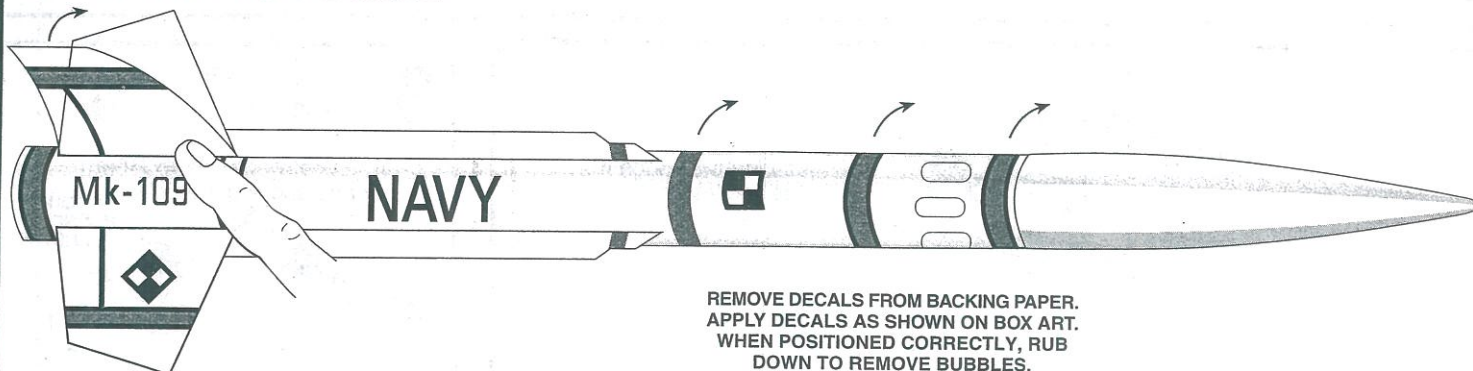

REMOVE DECALS FROM BACKING PAPER. APPLY DECALS AS SHOWN ON BOX ART. WHEN POSITIONED CORRECTLY, RUB DOWN TO REMOVE BUBBLES.

8. FLYING YOUR ROCKET

ROCKET PREPARATION

Remove nose cone, shock cord and parachute.

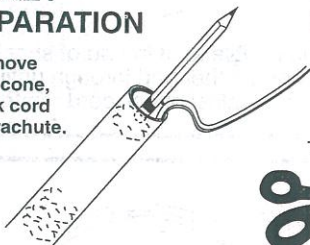

Crumple and insert three squares of recovery wadding. Repack and insert parachute, shock cord and nose cone.

ENGINE PREPARATION

Separate igniter and igniter plug.

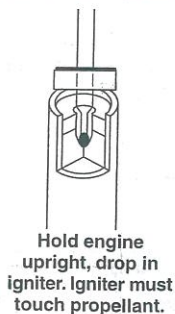
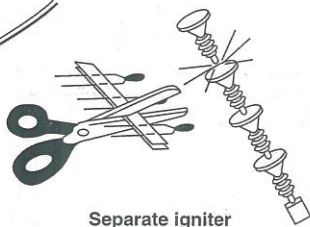

Hold engine upright, drop in igniter. Igniter must touch propellant.



Insert igniter plug.



Firmly push all the way in.



Bend igniter wires back.

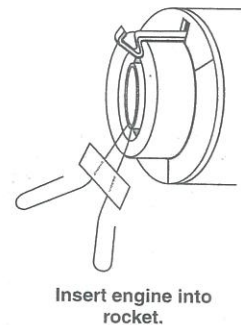

Insert engine into rocket.

LAUNCH SUPPLIES

To launch your rocket, you will need the following:

- Launch Pad (Estes Porta-Pad® II)
- Launch Controller (Estes Electron Beam®)
- Recommended Estes Engines: A8-3, B4-4, B6-4, B6-6, C6-5 or C6-7. For your first flight, use an A8-3 engine.
- Recovery Wadding (EST 302274)
- Igniters and Igniter Plugs (included with Estes engines)

Use only Estes products to launch this rocket.

ENGINE	PROJECTED ALTITUDE	
	Feet	Meters
A8-3.....	190.....	58
B4-4/B4-6.....	475.....	145
B6-4/B6-6.....	510.....	155
C6-5/C6-7.....	1050.....	320

TIPS FOR FLYING YOUR ROCKET

- Choose a large field away from power lines, buildings, tall trees, and low flying aircraft. Try to find a field at least 76 meters (250 feet) square. The larger the launch area, the better your chance of recovering your rocket.
- Launch area must be free of dry weeds and brown grass.
- Launch only during calm weather with little or no wind and good visibility.
- Don't leave parachute packed more than a minute or so before launch during cold weather (colder than 4° Celsius [40° Fahrenheit]). Parachute may be dusted with talcum or baby powder to avoid sticking.
- Always follow the National Association of Rocketry (NAR) MODEL ROCKETRY SAFETY CODE while participating in any model rocketry activities. The safety code is enclosed with this kit.

COUNTDOWN AND LAUNCH

- 10...** Safety key must not be in launch controller.
The safety cap with safety key attached should already be on the launch rod.

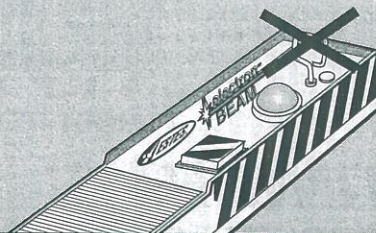

- 9...** Remove safety cap from launch rod, slide launch lugs over rod. Make sure rocket slides freely and micro-clips are clean for good electrical contact.

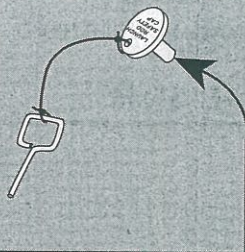

- 8...** Attach micro-clips to the igniter wires. Arrange the micro-clips so they do not touch each other or the metal blast deflector. Attach micro-clips as close to protective tape on igniter as possible.

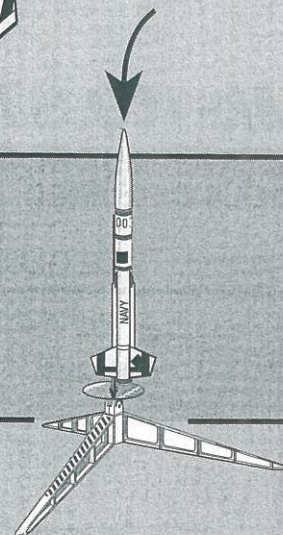
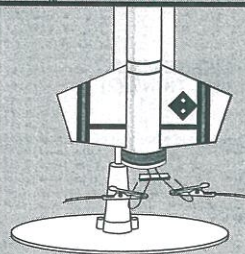

- 7...** Move everyone back from your rocket as far as launch wire will permit (at least 5 meters - 15 feet).

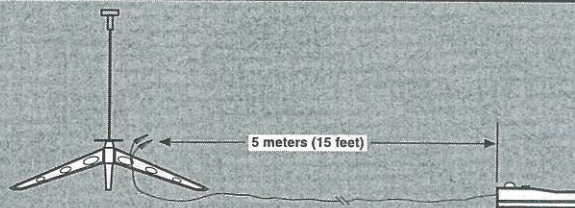

- 6...** Insert safety key to arm the launch controller.

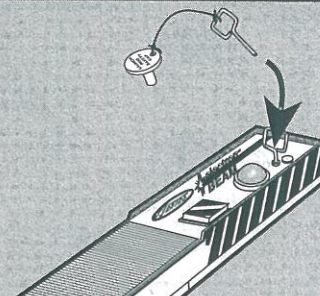

- 5...** Start audible countdown.

4...3...2...1...

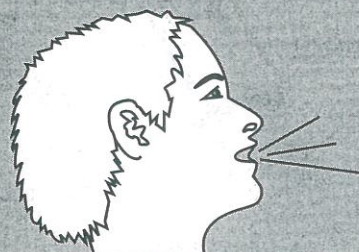

LAUNCH!

Push and hold button until engine ignites.

For safety, immediately remove safety key from launch controller and replace safety cap on launch rod.

MISFIRES

When an ignition failure occurs, remove the safety key from the launch control system and wait one minute before approaching the rocket. Remove the expended igniter from the engine and install a new one. Be certain the coated tip is in direct contact with the engine propellant. Broken or chipped coating will not affect the performance of the igniter. Reinstall the igniter plug as illustrated previously. Repeat the countdown and launch procedure.