

11. ATTACH FINS

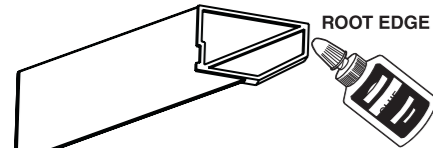

A. Apply a thin layer of foam safe glue to the root edge and raised surfaces on sides of one fin as shown. Insert fin into fin slot so root edge touches body tube and outside edges are flush with foam body.

NOTE: Fins must be attached correctly for stable flight!

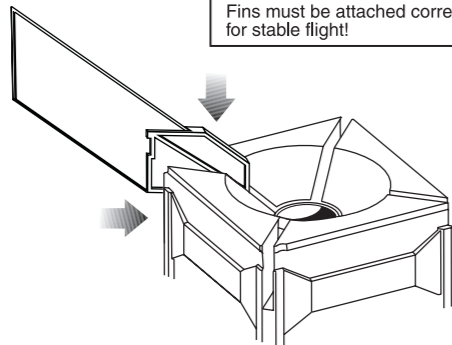

B. Repeat for remaining fins.

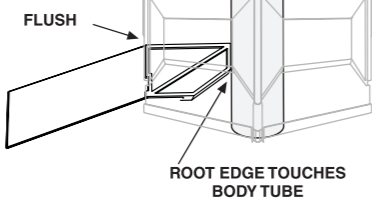

12. APPLY DECALS

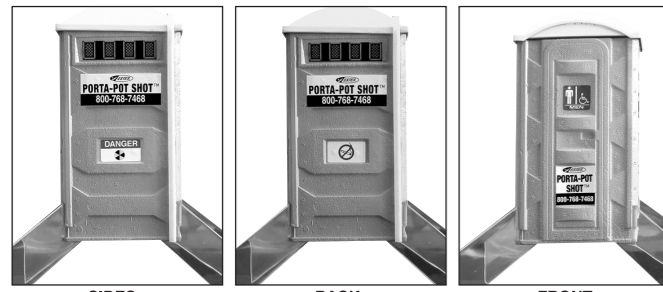

A. Make sure paint is dry first. Peel decals one at a time from backing sheet and apply as shown. Rub down to remove bubbles.

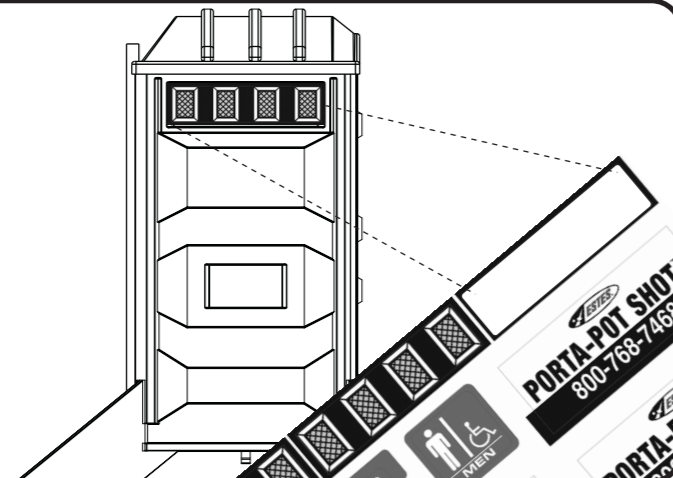

13. PREPARE PARACHUTE FOR FLIGHT

IMPORTANT:

Wadding must be in place and slide freely for rocket to work properly.

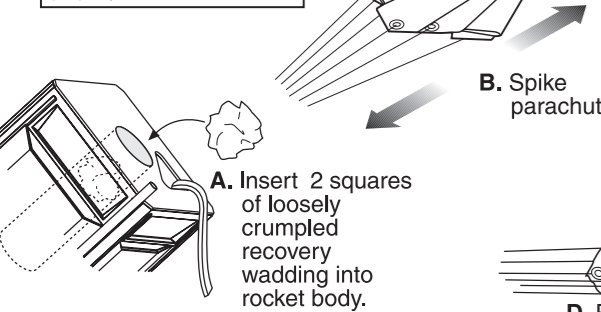

C. Fold.

B. Spike parachute.

D. Roll.

IMPORTANT:

Parachute should slide easily into body. If fit is too tight, unfold and repack again.

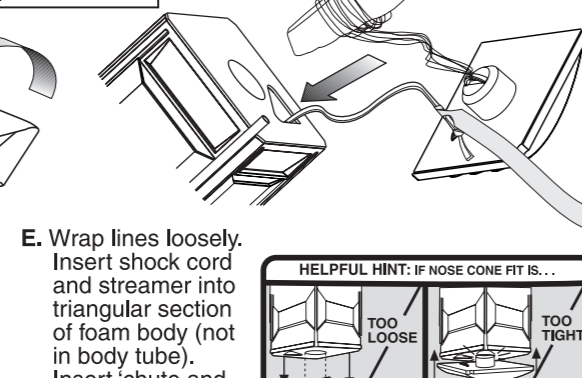

E. Wrap lines loosely. Insert shock cord and streamer into triangular section of foam body (not in body tube). Insert chute and nose cone (roof) into body tube.

NOTE: Only Estes wadding (#302274) recommended!

14. PREPARE ENGINE

WARNING: FLAMMABLE

To avoid serious injury, read instructions & NAR Safety Code included with engines. **PREPARE ENGINE ONLY WHEN YOU ARE OUTSIDE AT THE LAUNCH SITE PREPARING TO LAUNCH!** If you do not use your prepared engine, remove the igniter before storing engine.

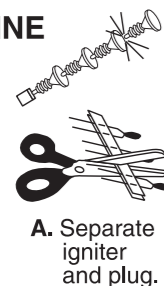

A. Separate igniter and plug.

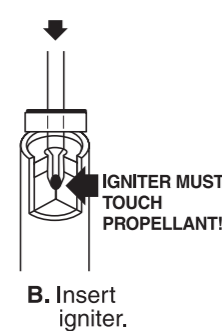

B. Insert igniter.



C. Insert plug.



D. Push down.

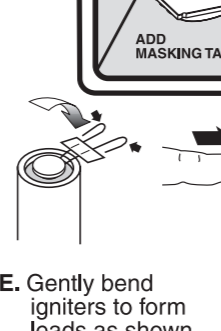

E. Gently bend igniters to form leads as shown.

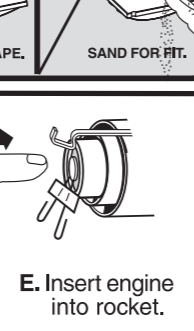

E. Insert engine into rocket.

HELPFUL HINT: IF NOSE CONE FIT IS...



TOO LOOSE **TOO TIGHT**



ADD MASKING TAPE. **SAND FOR FIT.**

COUNTDOWN AND LAUNCH



KEY ALWAYS OUT UNTIL FINAL COUNTDOWN!

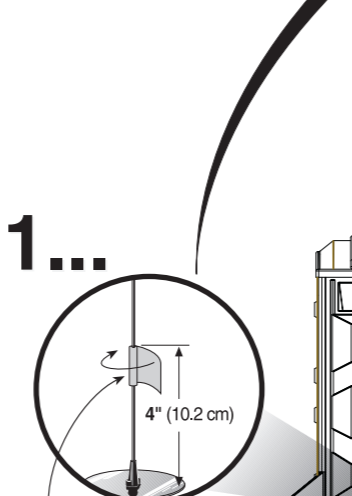

1...

MASKING TAPE

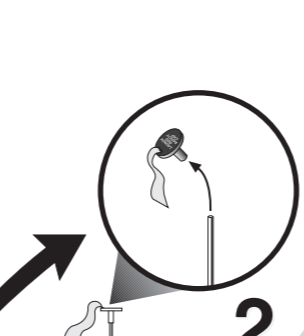

2...

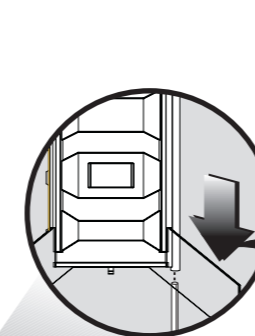

3...

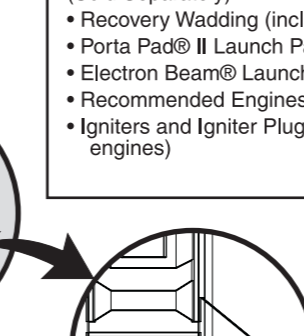

4...

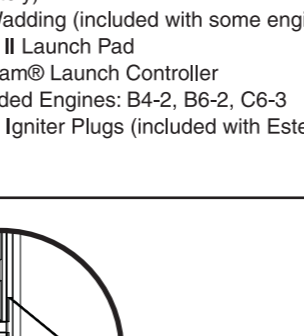

KEY

5...

4...3...2...1...

INSERT KEY. PUSH DOWN FIRMLY AND HOLD.

WHILE HOLDING KEY DOWN, PRESS LAUNCH BUTTON UNTIL LIFTOFF!

ESTES LAUNCH SUPPLIES

- (Sold Separately)
- Recovery Wadding (included with some engines)
- Porta Pad® II Launch Pad
- Electron Beam® Launch Controller
- Recommended Engines: B4-2, B6-2, C6-3
- Igniters and Igniter Plugs (included with Estes engines)

PRECAUTIONS



NO DRY GRASS OR WEEDS

PRE-LAUNCH CHECK

For safety, never launch a damaged rocket. Check the rocket's body, nose cone and fins. Also, check the engine mount, recovery system and launch lug(s). Repair any damage before launching the rocket.

FLYING YOUR ROCKET

Choose a large field (250 ft. [76 m] square) free of dry weeds and brown grass. The larger the launch area, the better your chance of recovering your rocket. Football fields and playgrounds are great. Launch only with little or no wind and good visibility.

Always follow the National Association of Rocketry (NAR) SAFETY CODE.

MISFIRES

TAKE THE KEY OUT OF THE CONTROLLER. WAIT ONE MINUTE BEFORE GOING NEAR THE ROCKET! Disconnect the igniter clips and remove the engine. Take the plug and igniter out of the engine. If the igniter has burned, it worked but did not ignite the engine because it was not touching the propellant inside the engine. Put a new igniter all the way inside the engine without bending it. Push the plug in place. Repeat the steps under Countdown and Launch.



Estes Industries
1295 H Street
Penrose, CO 81240

PRINTED IN CHINA

PORTA-POT SHOT™

#2117

FLYING MODEL ROCKET KIT INSTRUCTIONS
KEEP FOR FUTURE REFERENCE

ASSEMBLY TIP: Read all instructions before beginning work on your model. Make sure you have all parts and supplies.

TEST FIT ALL PARTS TOGETHER BEFORE APPLYING ANY GLUE!
If any parts don't fit properly, sand as required for precision assembly.

PARTS Locate the parts shown below and lay them out on the table in front of you. **DO NOT USE THIS DRAWING TO ASSEMBLE YOUR ROCKET.**

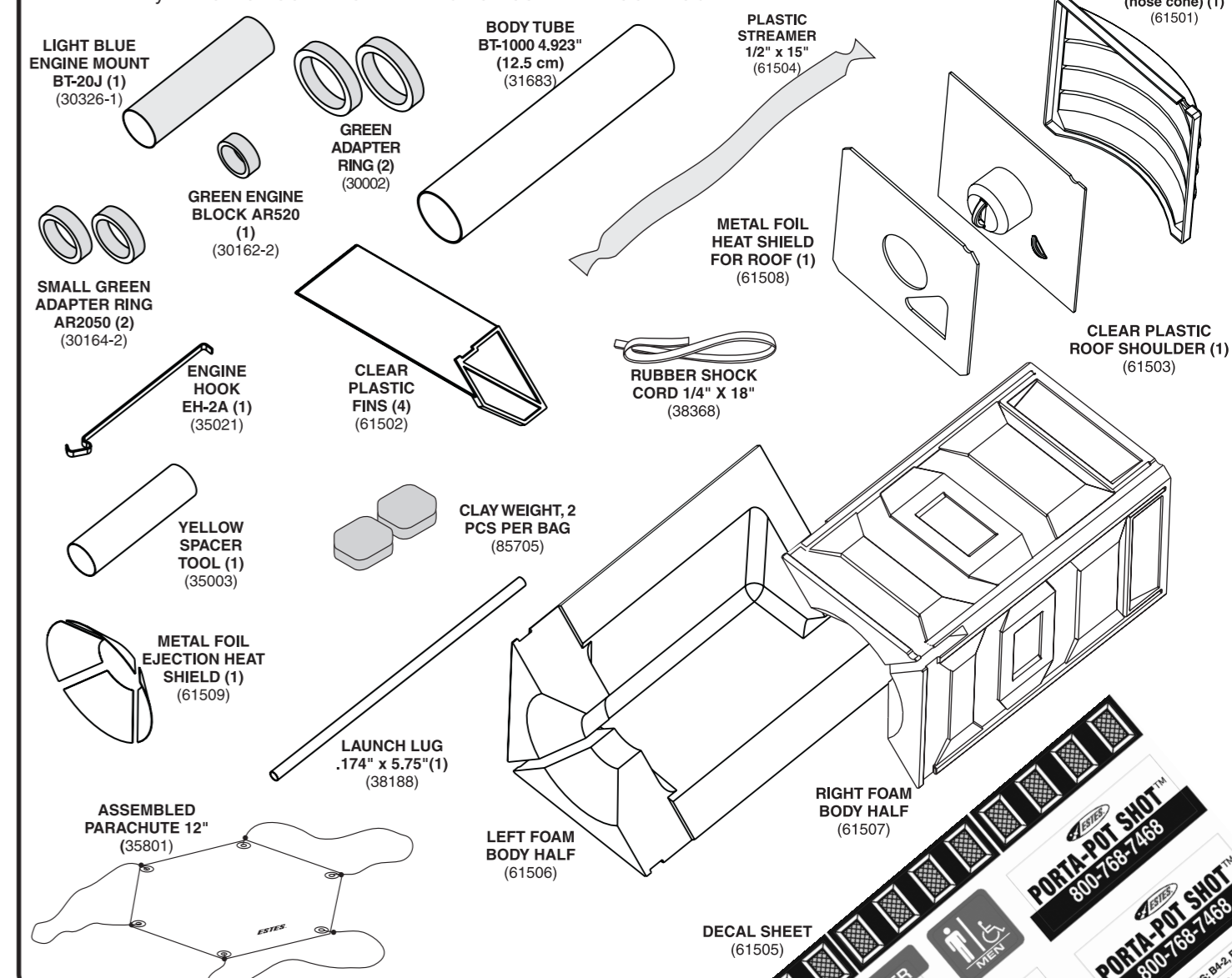

SUPPLIES In addition to the parts included in the kit you will also need:



CAUTION (DO NOT USE LACQUER BASED PAINT - IT WILL ATTACK THE FOAM)

1. ASSEMBLE ENGINE MOUNT

A. Measure and mark engine mount tube at 1/2" (13 mm) and 2-1/2" (6.4 cm).

B. Cut 1/8" (3 mm) slit at 2-1/2" (6.4 cm) mark.

C. Use scrap balsa to smear glue just short of the 2-1/2" mark (6.4 cm) inside engine mount tube.

D. Mark yellow spacer tool 1/4" (6 mm) from end.

E. Push engine block into engine mount tube with spacer tool up to 1/4" (6 mm) mark. **Remove spacer tool immediately.** Let dry.

F. Insert engine hook.

G. Sand inside edges of both small green adapter rings (AR2050) as needed.

H. Apply a ring of glue around tube just past the 1/2" (13 mm) mark. Slide one adapter ring onto engine mount tube up to the 1/2" (13 mm) mark. Apply a ring of glue around tube just past the 2-1/2" (6.4 cm) mark. Slide the other adapter ring onto engine mount tube up to the 2-1/2" (6.4 cm) mark. Apply glue fillets to both sides of rings. Let dry completely.

2. INSERT ENGINE MOUNT

A. Using a piece of scrap balsa, smear glue inside BT-1000 body tube 2-1/4" (5.7 cm) from end.

B. Push engine mount into body tube until both ends are flush. Let dry completely.

3. ASSEMBLE ROOF (NOSE CONE)

A. Remove both pieces of clay from bag and form together into a ball. Place it in the recessed area of the clear plastic roof shoulder as shown.

B. Apply plastic cement to the three mating edges of the clear plastic roof. Make sure the roof shoulder is oriented correctly and glue in place (smashes the clay very slightly). Let dry completely.

4. PAINTING YOUR OUTHOUSE

IMPORTANT:
Do not use lacquer based paints on the foam body. It will attack and damage the foam. Use a water-based paint or hobby grade enamel.

A. Carefully unpack foam body halves and discard packaging (including cardboard piece on ends).

B. Select paint to match the color scheme on the package, or choose your own.

C. Paint the outside of foam body and roof. Let dry.

5. ASSEMBLE BODY TUBE

A. Measure and mark engine body tube at 1/2" (13 mm) and 4-1/16" (10.3 cm).

B. Apply a ring of glue around tube at the 1/2" (13 mm) mark and slide one green adapter ring (30002) just past the 1/2" (13 mm) mark as shown.

C. Apply a ring of glue around tube at the 4-1/16" (10.3 cm) mark. Slide the other green adapter ring down to the 4-1/16" (10.3 cm) mark as shown. Let dry.

D. Apply glue fillets to middle side only of both rings as shown. Let dry completely.

6. INSTALL SHOCK CORD MOUNT

A. Cut out shock cord mount.

B. Fold.

C. Apply glue. Fold forward.

D. Apply glue. Fold forward.

E. Squeeze tightly and hold for one minute.

F. Glue shock cord mount to outside of assembled body tube just below the top adapter ring as shown. Hold until glue sets. Let dry.

7. ASSEMBLE FOAM BODY

A. Apply foam safe glue to recessed area on one foam body half where body tube will mate.

B. Position body tube assembly inside one foam body half with the engine hook oriented between fin slots and the shock cord oriented near the side with the triangular opening at the top as shown. The shock cord should extend through the triangular opening at the top. The green rings should fit just inside the foam body shoulders to prevent minimal movement of the body tube.

C. Glue in place.

D. Apply foam safe glue to mating surfaces of one body half as shown. Make sure the other half is oriented properly and the shock cord is out of the way, then glue in place.

IMPORTANT:
Use only white carpenter's glue or foam safe CA. Other glues will attack and damage the foam.

8. ATTACH HEAT SHIELDS

A. Stuff the shock cord back inside the foam body through the triangular opening in the top. Trim body tube flush with top of foam if required.

B. Remove the heat shield for the roof from the metal foil. Remove the paper backing to reveal the adhesive side and carefully tape the heat shield for the roof in place as shown. Pull or shake the shock cord back out through the triangular opening.

C. Remove the ejection heat shield for the bottom from the metal foil. Note the grooved line on one end. Remove the paper backing from opposite end and tape over top of grooved end so the end is lined up with the groove forming a three dimensional "ring". Remove the remainder of the backing and carefully tape the ejection shield "ring" in place as shown.

9. ATTACH LAUNCH LUG

A. There is a slot in the right rear of the foam body to glue the launch lug. Make sure the bottom of the launch lug is flush with the bottom of the body (so it extends past the body on the top). Glue in place using foam safe glue.

B. Make sure launch lug is aligned properly before glue dries. Let dry.

10. ATTACH PARACHUTE & SHOCK CORD

A. Pass parachute shroud lines through middle eyelet.

B. Form a loop with shroud lines.

C. Pass parachute through loop. Pull tight.

D. Tie loose end of shock cord to eyelet in corner of roof. Use a double knot. Tie plastic streamer to shock cord about 1" (25mm) from eyelet.