

HONEST JOHN

SURFACE-TO-SURFACE MISSILE

HONEST JOHN was the U.S. Army's first surface-to-surface unguided rocket used as a long-range artillery weapon. It is stabilized during flight by fins and is provided initial guidance by means of a launching rail. Eight small, solid propellant spin rockets housed in four shrouds behind the warhead are ignited as the Honest John is launched and impart a slow spin to the missile during flight to minimize effects of fin and thrust misalignments (This improves accuracy.).

The Honest John's solid propellant booster was originally developed as a launch booster for the Navy's "Talos" XSAM-N-6 ram-jet anti-aircraft missile but was later replaced by an improved booster. Early experiments with JATO rockets adapted to fly as fin-stabilized missiles were carried out in 1950 at White Sands and led to the combination of the M6 (X202-E2) booster with a 30-inch diameter special warhead to produce the Honest John. The first Honest John was fired at White Sands on June 30, 1951.

The Honest John motor weighs about 4000 pounds. Total weight of an Honest John is nearly 5000 pounds. Its motor produces about 85,000 pounds of thrust for 5.2 seconds giving it a maximum range of approximately 25 miles.

Honest John production was undertaken in 1952 with Douglas Aircraft Company as prime contractor. Hundreds of rounds were fired at White Sands to establish battlefield range tables, wind effects, and mobile launcher design. Considerable difficulty was experienced with quenching the huge cloud of exhaust smoke produced at launch, a factor which might make a launch site a perfect target following launch of a missile. The missile was placed in the hands of special rocket batteries and deployed to many overseas locations.

The M31 series Honest John has been replaced by the M50 series, but still remains a favorite among scale fans.

MISSILE SPECIFICATIONS

LENGTH: 327 inches

MAXIMUM DIAMETER: 30 inches

MOTOR DIAMETER: 23 inches

FIN SPAN: 104 inches

WARHEAD LENGTH: 115 inches

Scale used in MAXI HONEST JOHN kit is 8.85:1.

ABOUT THE MODEL:

Your giant-sized rocket kit is a 1/9th scale model of the free-flight surface-to-surface Honest John, a tactical missile to provide close fire support for ground combat operations. Your Honest John model rocket is designed to be flown with a D12-3 solid-propellant engine.

For best flight performance, it is important to build the model as lightweight as possible. Avoid using unnecessary amounts of glue, body putty and paint. The lighter you build it, the higher it will fly. Due to the model's large size, it should be launched only from a sturdy launch pad. A 3/16" diameter launch rod is required for best lift-off results.

NOTE: Wash all plastic parts, rinse thoroughly and dry before beginning construction.



ESTES INDUSTRIES
PENROSE, COLO. 81240

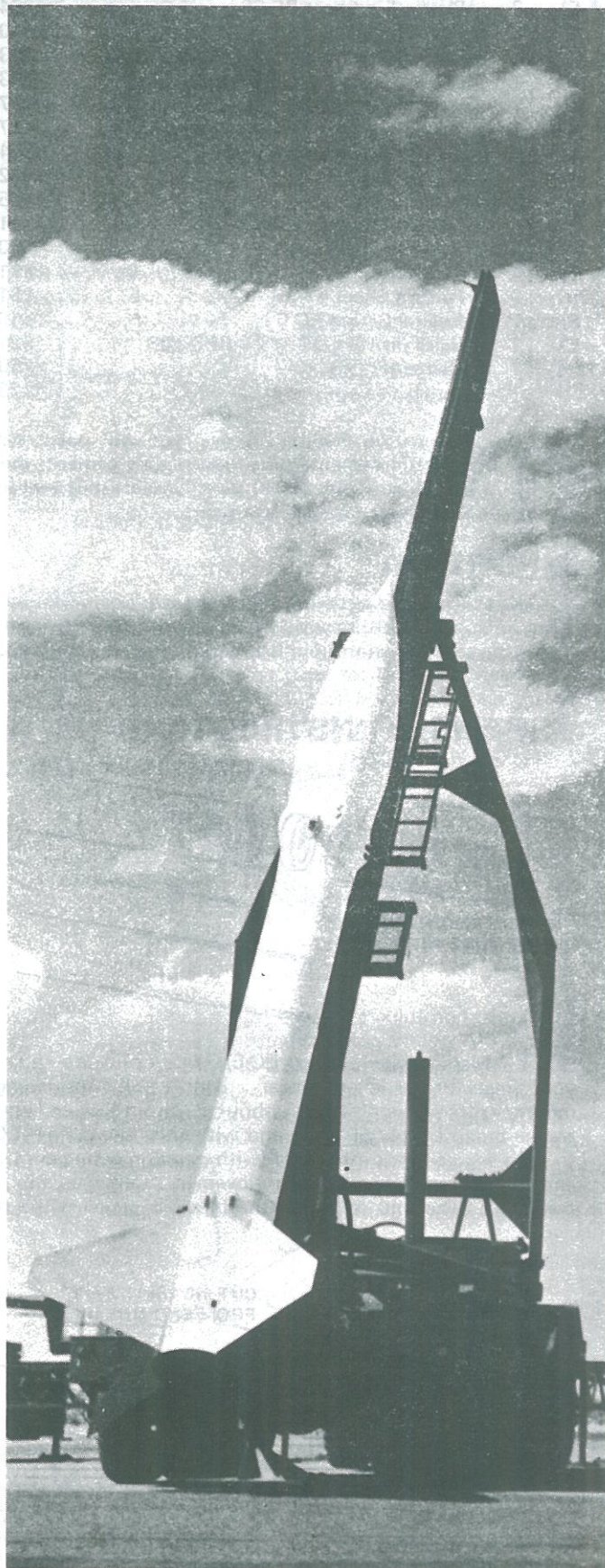

PARTS LIST

A)	1	Ring Set TA-69	30052
B)	1	Body Tube BT-80KD (14.2 inches long)	30433
C)	1	Launch Lug LL-3B	38187
D)	1	Plastic Nose Cone	71065
E)	1	Plastic Boattail Unit	71066
F)	2	Plastic Fin Sheet PF-69	32469
G)	1	Decal KD-69	37069
H)	1	Body Tube BT-50L (12.7 inches long)	30366
I)	1	Body Tube BT-52S (3.9 inches long)	30380
J)	1	Shock Cord SC-2MJ (30 inches long)	85738
K)	1	Shock Cord SC-2 (18 inches long)	85736
L)	2	Set of 6 Tape Discs TD-3F	38406
M)	2	Shroud Line SLT-144	38241
N)	2	Parachute PK-24A	85568
O)	1	Engine Block AR-2050	30164
P)	1	Engine Hook EH-2	35025
Q)	1	Instructions	83150
R)	1	Pattern Sheet SP-69	83152
S)	1	Engine Casing EC-6	35012
T)	1	Balsa (1/16" x 1/2" x 6") BFS-20B	32104
U)	1	Balsa (1/8" x 3" x 3")	75015
V)	1	Adhesive Capsule	37828

In addition to the materials above, you will need: White glue; liquid plastic cement; tube-type plastic cement; model knife or single edge razor blade; pencil; ruler; metal straight edge; masking tape; sandpaper; and paint.

IMPORTANT:

Read all instructions before beginning work on your Honest John. When you are thoroughly familiar with the construction sequence, begin construction. Check off each step as you complete it.

ASSEMBLY INSTRUCTIONS

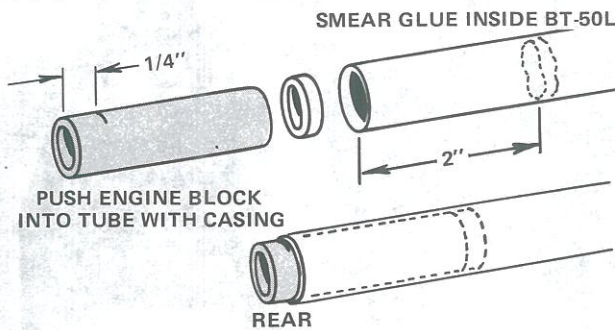

1 Mark engine casing (EC-6) 1/4" from one end. Use your finger or a stick to smear a band of glue inside engine mount/stuffer tube (BT-50L) about 2" from one end. Insert engine block (AR-2050) into end with glue. Use casing (EC-6) to push engine block into place (with mark on casing even with end of tube) with one smooth movement. Remove casing immediately. The end in which the block is glued is the rear.

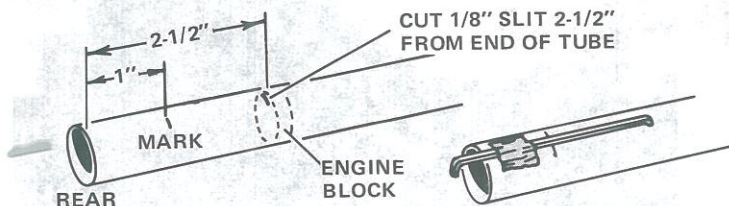

2 Cut a 1/8" slit in stuffer tube 2-1/2" from the rear. The slit will be even with the edge of the engine block. Mark stuffer tube 1" from rear end. Temporarily tape engine hook (EH-2) in place.

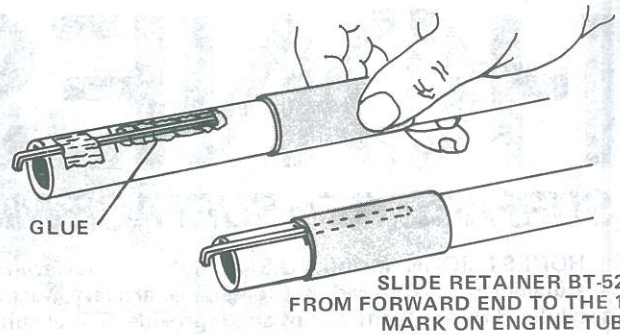

3 Apply a heavy line of glue on the engine hook from the 1" mark to the engine block end. Slip engine hook retainer (BT-52S) onto forward end of stuffer tube and slide it back over engine hook to the 1" mark. Wipe away any excess glue and remove tape from engine hook.

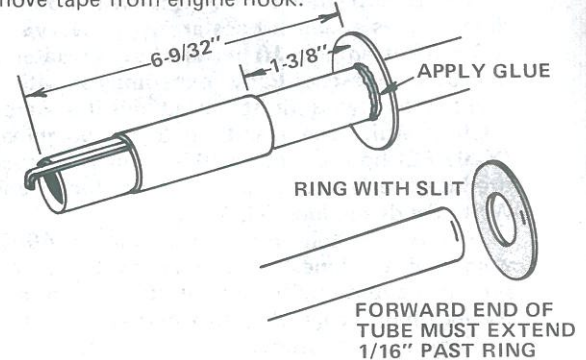

4 Remove centering rings from ring set (TA-69) and place on stuffer tube as shown. Glue securely in place and allow to dry. Apply a second layer of glue to joints for strength.

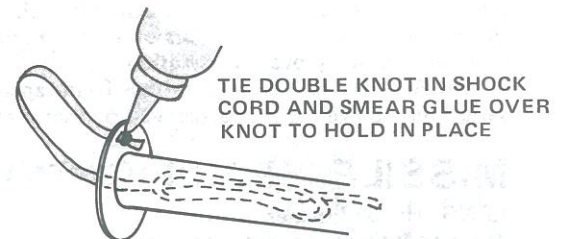

5 Tie a secure double knot at end of the 30" long shock cord (SC-2MJ). Slip unknotted end through slit in forward centering ring and pull knot against ring. Apply a liberal coating of glue over knot to hold it in place.

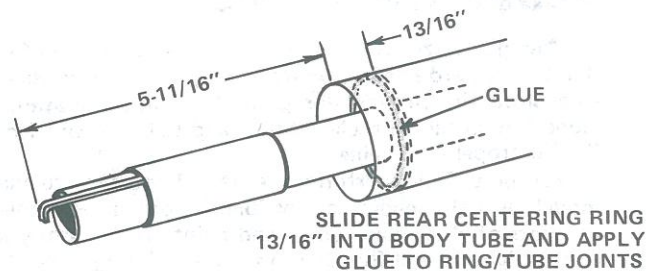

6 Mark inside of main body tube (BT-80KD) 13/16" from one end. Place engine mount/stuffer tube assembly inside main body tube so that engine hook is exposed at marked end of main body tube after insertion. Slide assembly in until rear centering ring is even with the 13/16" mark. Apply glue to ring/tube joints at both ends. After these joints are fully dry, apply a second coat of glue to ring/tube joints. These joints must be sealed properly to minimize loss of ejection gases.

NOTE: ENDS OF BANDS ARE STAGGERED TO GIVE A SMOOTHER FINAL BAND.

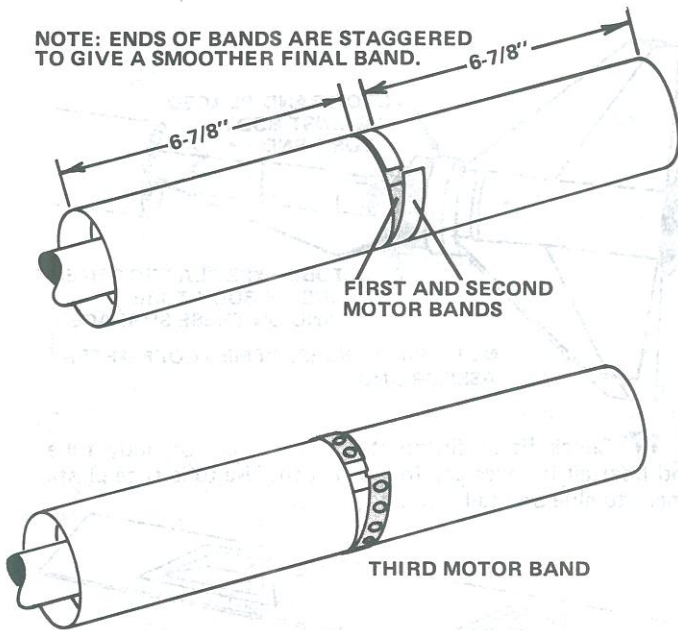

FIRST AND SECOND MOTOR BANDS

THIRD MOTOR BAND

7 Carefully cut the three motor bands from pattern sheet (SP-69). Cut small holes out of third motor band. Glue first band around body tube with its edges 6-7/8" from ends of body tube (centered). Glue second band on top of first band (for best results, position ends of second band around body tube from ends of first band so ends are staggered). After first and second bands are dry, glue third band on top of second band (rotate its ends, also).

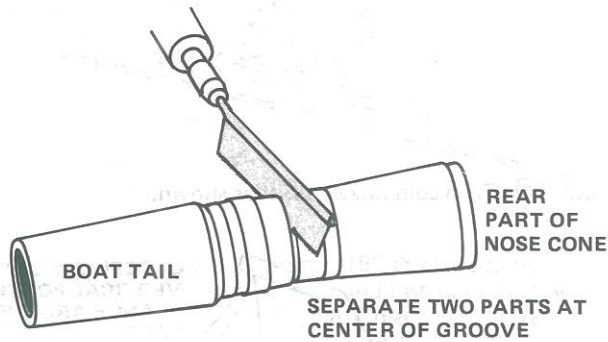

BOAT TAIL

REAR PART OF NOSE CONE

SEPARATE TWO PARTS AT CENTER OF GROOVE

8 If you have a razor saw, use it to cut boattail unit into two parts as shown. If you do not have a razor saw, use model knife or single edge razor blade. Make a very light cut around parting line (bottom of groove) and repeat until you have cut completely through the plastic. Work carefully to avoid tearing plastic. One piece is the boattail, and other piece is rear part of nose cone.

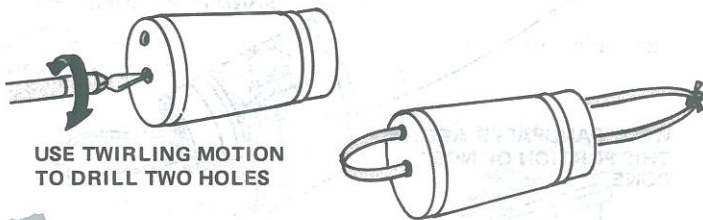

USE TWIRLING MOTION TO DRILL TWO HOLES

TIE ENDS TOGETHER SECURELY

9 Use model knife (with a twirling motion) to drill two holes (about 1/4" diameter) in forward end of rear nose cone piece. Place ends of 18" shock cord (SC-2) through holes and tie together securely.

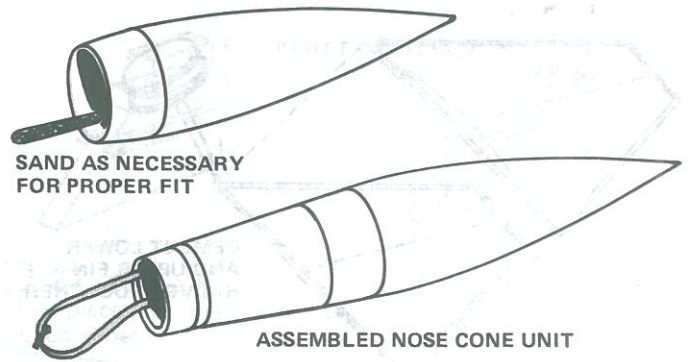

SAND AS NECESSARY FOR PROPER FIT

ASSEMBLED NOSE CONE UNIT

10 Check for proper fit of two nose cone pieces. If necessary, lightly sand inside of forward cone for correct fit. Glue parts together using liquid plastic cement and set aside to dry.

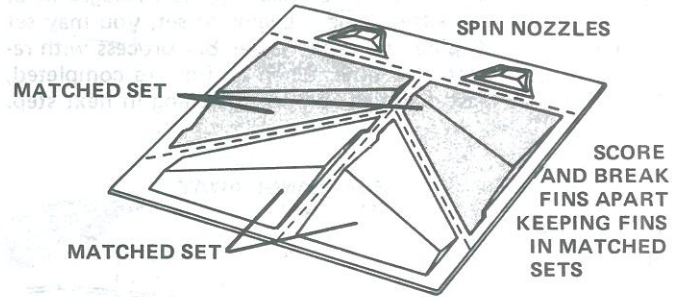

SPIN NOZZLES

MATCHED SET

SCORE AND BREAK FINS APART KEEPING FINS IN MATCHED SETS

MATCHED SET

11 Remove the eight fin halves from molded plastic sheets (PF-69) by scoring (cutting partially through the plastic) and gently bending back and forth to break on score lines. Leave a wide flange around parts for later use. Keep matched fin halves together by marking or by taping each fin set together.

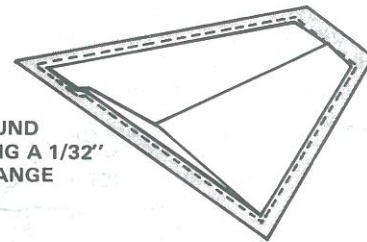

SCORE AROUND FINS LEAVING A 1/32" TO 1/16" FLANGE

12 Use metal straight edge as a guide and trim fin halves (using score and break method), leaving a flange 1/32" to 1/16" wide around each fin half. Work carefully.

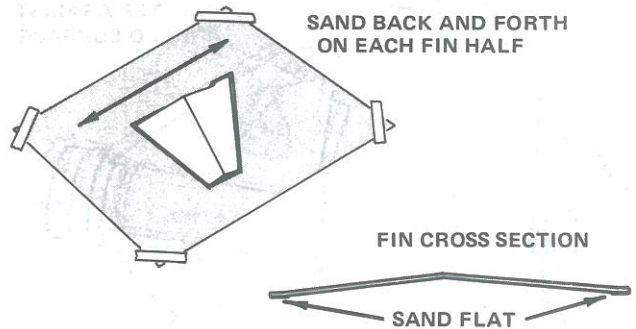

SAND BACK AND FORTH ON EACH FIN HALF

FIN CROSS SECTION

SAND FLAT

13 Tape a 8-1/2"x11" sheet of 100 grit sandpaper to a flat work surface. Sand back of each fin half until flange portion is about half of its original thickness. This will provide a smooth fit between fin halves and a strong, neat joint when cemented together.

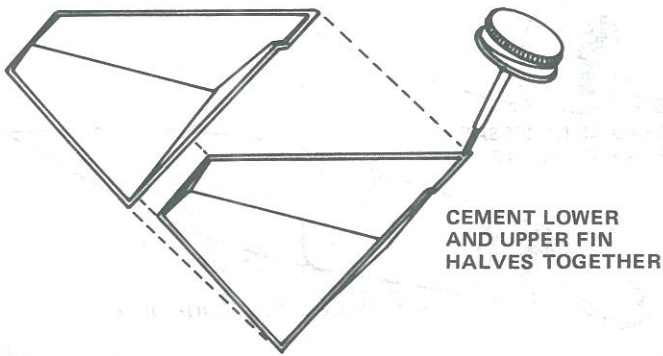

14 Be sure fin halves are arranged into matched sets. Work with one set of fin halves at a time. Apply liquid plastic cement to flange surfaces on both fin halves and press firmly together. Check alignment of fin halves by sighting down edges in at least two directions. After cement begins to set, you may set completed fin unit aside and repeat assembly process with remaining fins, one set at a time. When all fins are completed, allow to dry at least overnight before trimming in next step.

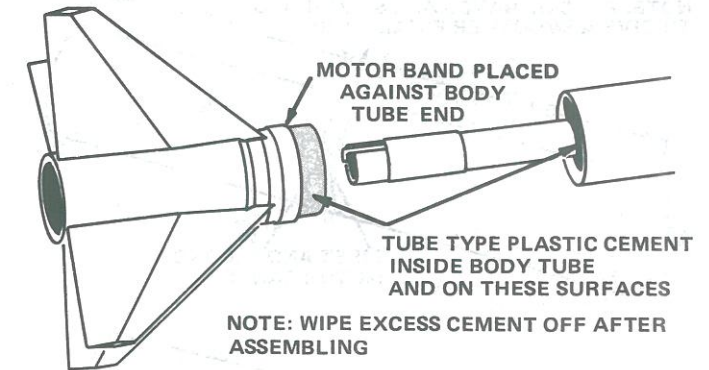

17 Check fit of fin/boattail unit in rear of body tube. Sand boattail if necessary for correct fit. Use tube type plastic cement to glue boattail into body tube.

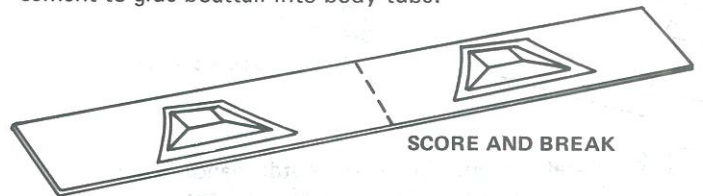

18 Use score and break technique to remove the four spin nozzle units from plastic sheets.



15 Use model knife or single edge razor blade to trim away most of flange around each fin. Use sandpaper to trim to final size. Use fine sandpaper for final sanding on fin edges. Use a final light coat of liquid plastic cement to seal fin edges. Slight gaps on root edges of fins are permissible.

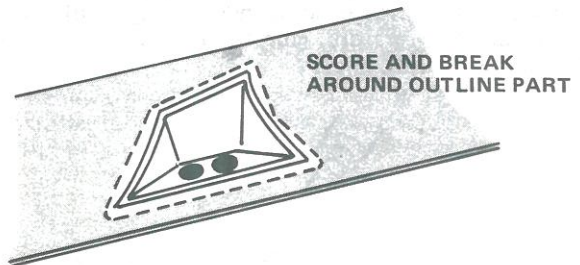

19 Trim spin nozzle units as shown.

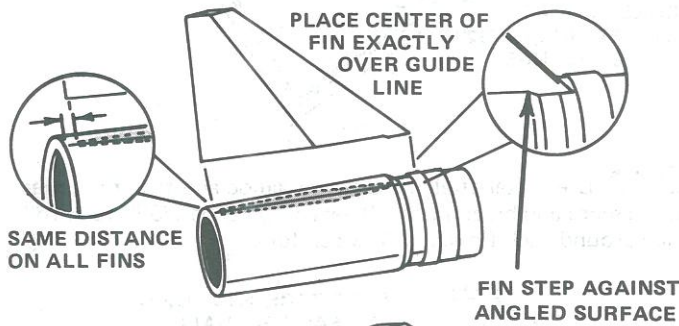

20 Use model knife or single edge razor blade to carefully cut away indicated areas of spin nozzles. After trimming part, flange will match contour of nose cone (will need light sanding).

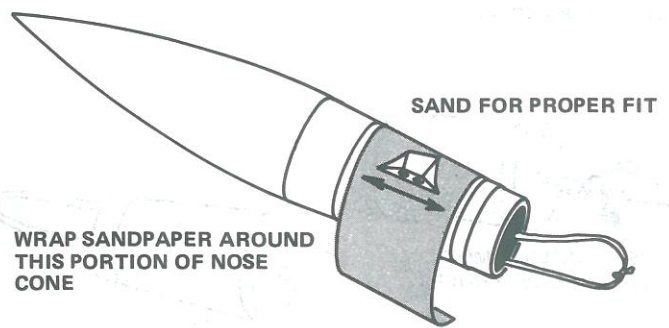
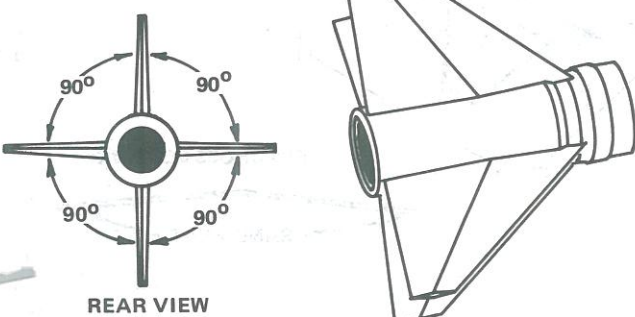

21 Wrap a sheet of sandpaper around rear portion of nose cone and sand base of each spin nozzle unit until it matches contour of nose cone.

16 Use liquid plastic cement to cement fins to boattail. Place center of fins over guide lines on boattail. Check frequently while cement is setting up to maintain correct alignment.

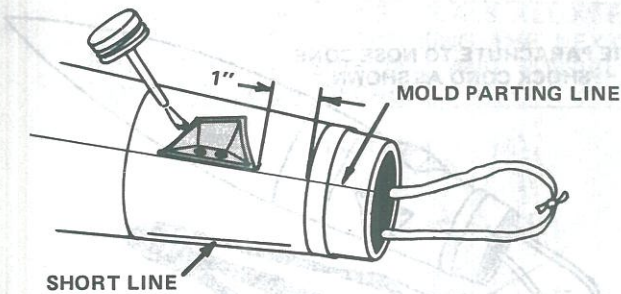

22 On the rear part of the nose cone are four lines (two of which are mold parting lines, running full length of part; and two short lines at 90° to mold parting lines). Use liquid plastic cement to glue spin nozzle units to nose cone. The left hand side of each unit should be against one of the four lines on nose cone. The bottom of each unit should be one inch above motor band detail (molded into nose cone).

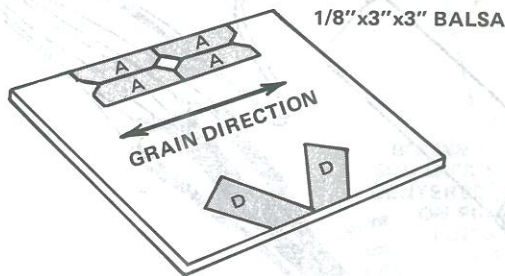

23 Cut patterns A and D from pattern sheet (SP-69). Cut four A pieces and two D pieces from 1/8" thick balsa.

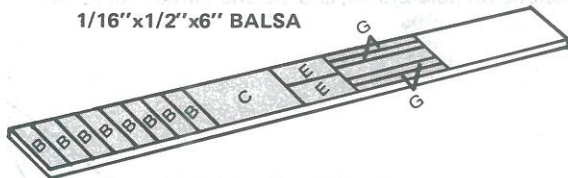

24 Cut parts B, C, E, and G from 1/16" thick balsa (BFS-20B). Lay out as shown on pattern sheet and instructions. You will have eight B pieces (3/16" x 1/2"), one C piece (1/2" x 7/8"), two E pieces (1/4" x 9/16"), and four G pieces (1/16" x 1").

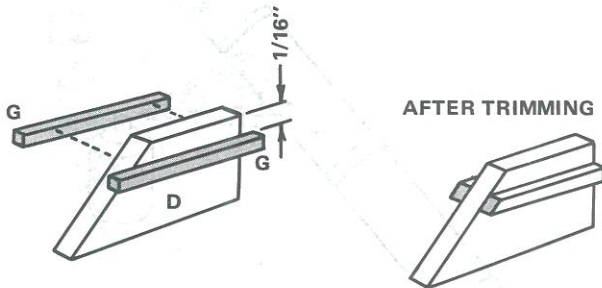

25 Glue two G pieces to each D piece. After glue has dried, trim and sand ends of G pieces as shown.

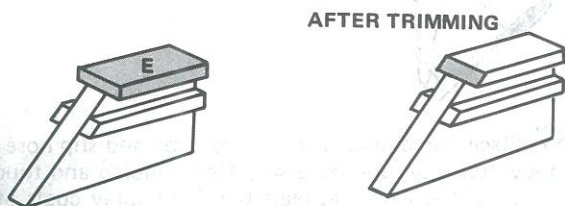

26 Glue E pieces to D pieces. After glue is dry, trim and sand to shape shown.

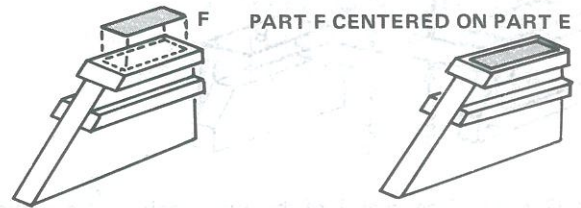

27 Cut two F pieces from pattern sheet and glue to top of E pieces, centered. This completes assembly of forward launch shoes.

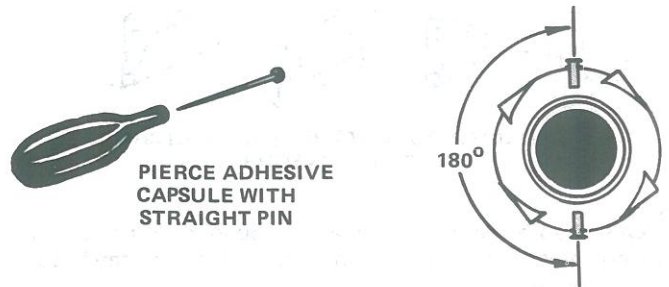
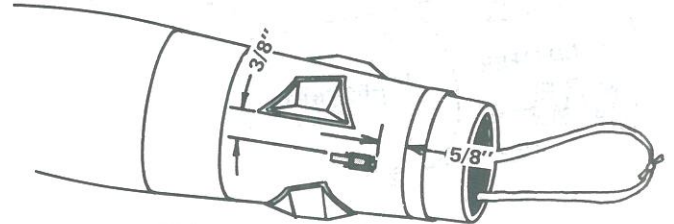

28 Use straight pin to pierce neck end of adhesive capsule. Apply a thin layer of cement to bottom of one launch shoe and position on nose cone while still wet. Do not allow it to contact nose cone until it is in the correct position. If you have smeared cement on unwanted areas, use a pencil eraser to rub it off after it dries.

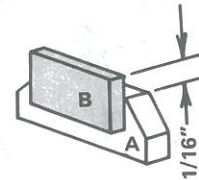

29 Glue one B piece to each A piece.

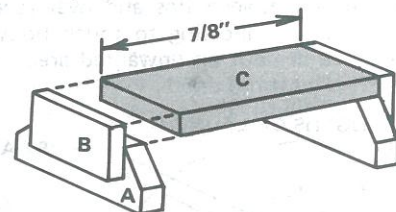

30 Glue C piece to two of the assemblies from step 29.

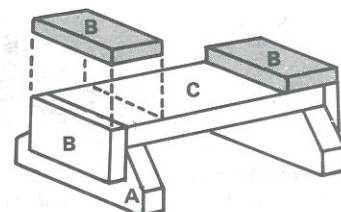

31 Glue two B pieces to assembly from step 30.

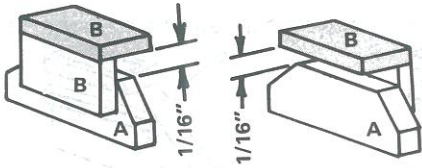

□ **32** Glue a B piece to each of the two remaining assemblies from step 29.

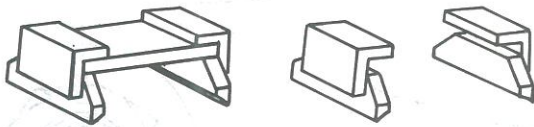
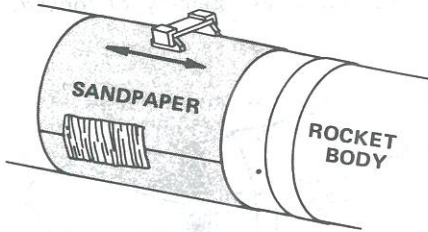

SAND UNTIL BOTTOMS OF PIECES MATCH BODY TUBE CONTOUR

□ **33** Wrap a piece of sandpaper around rocket body and sand bottoms of rear launch shoe assemblies to match contour of body tube.

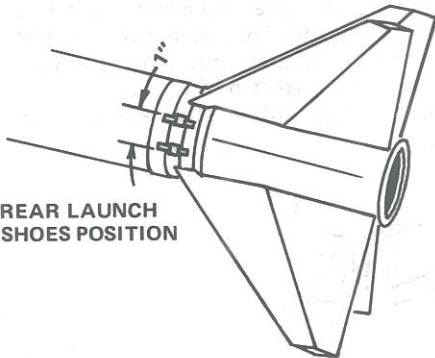

REAR LAUNCH SHOES POSITION

REAR LAUNCH SHOES CENTERED BETWEEN FINS



END VIEW

□ **34** Apply a thin layer of cement (from adhesive capsule) to bottoms of rear launch shoes and attach to rocket while still wet. Center carefully between fins and over recess between rear motor bands before allowing to touch body of rocket. If you have smeared cement on unwanted areas, use a pencil eraser to rub it off after it has dried.

CUT TWO 1/2" LENGTHS OF LAUNCH LUG AND GLUE AS SHOWN

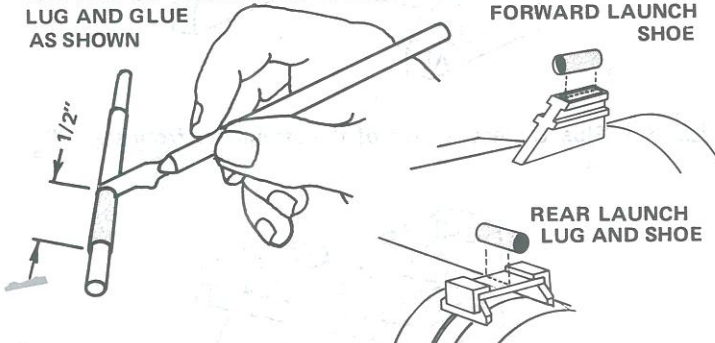

FORWARD LAUNCH SHOE

REAR LAUNCH LUG AND SHOE

□ **35** Using a dowel or stick for internal support, cut two 1/2" lengths from launch lug (LL-3B) and glue one to a forward launch shoe and one to piece C on rear launch shoe assembly.

TIE PARACHUTE TO NOSE CONE SHOCK CORD AS SHOWN

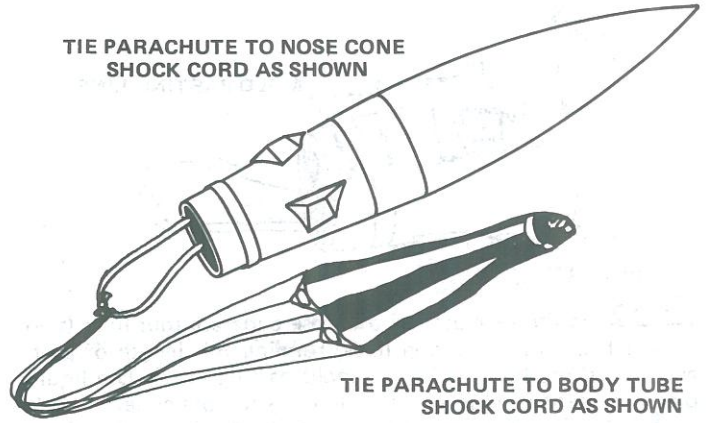

TIE PARACHUTE TO BODY TUBE SHOCK CORD AS SHOWN

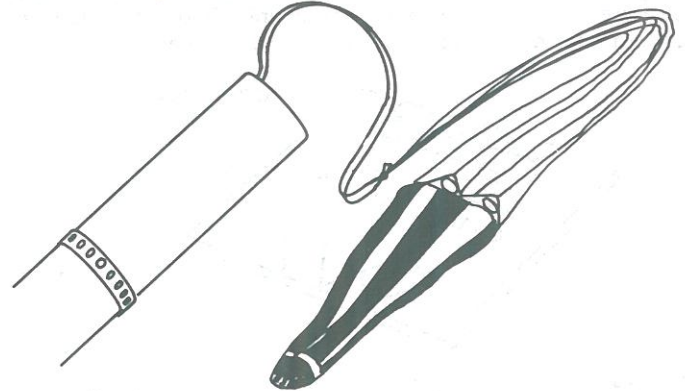

□ **36** Assemble the two parachutes (PK-24A's) following instructions on parachutes, and tie one parachute to each shock cord.

PLACE NOSE CONE IN ROCKET AND PAINT

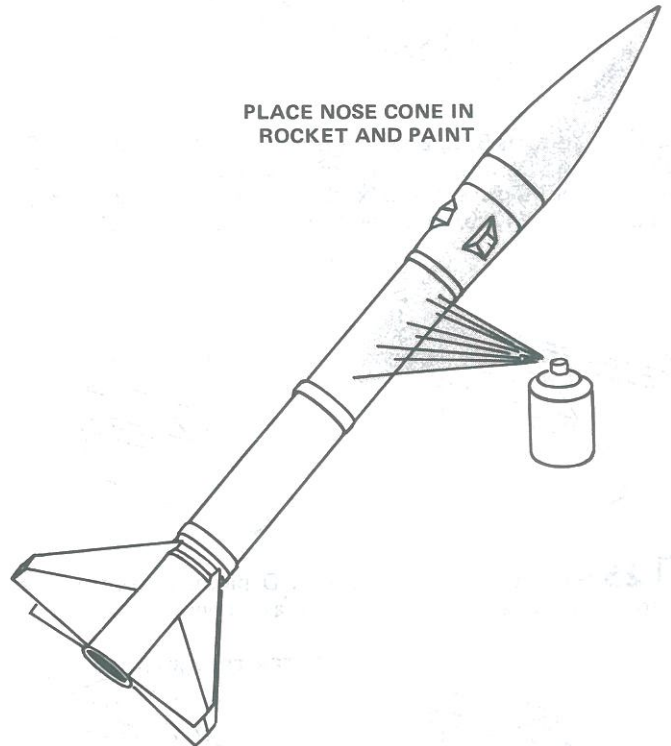

□ **37** Place parachutes inside body tube and slip nose cone into body tube. Do any necessary final sanding and touching up of glue joints. Apply at least two light spray coats of flat artillery olive. Work for a uniform color, but do not weigh your bird down with too much paint. Allow to dry thoroughly before applying decals.

NOTE: WHEN APPLYING DECALS, ALLOW EACH DECAL TO "SET" BEFORE APPLYING THE NEXT ONE. THIS WILL PREVENT SHIFTING AND POSSIBLY RUINING SOME OF YOUR DECALS.

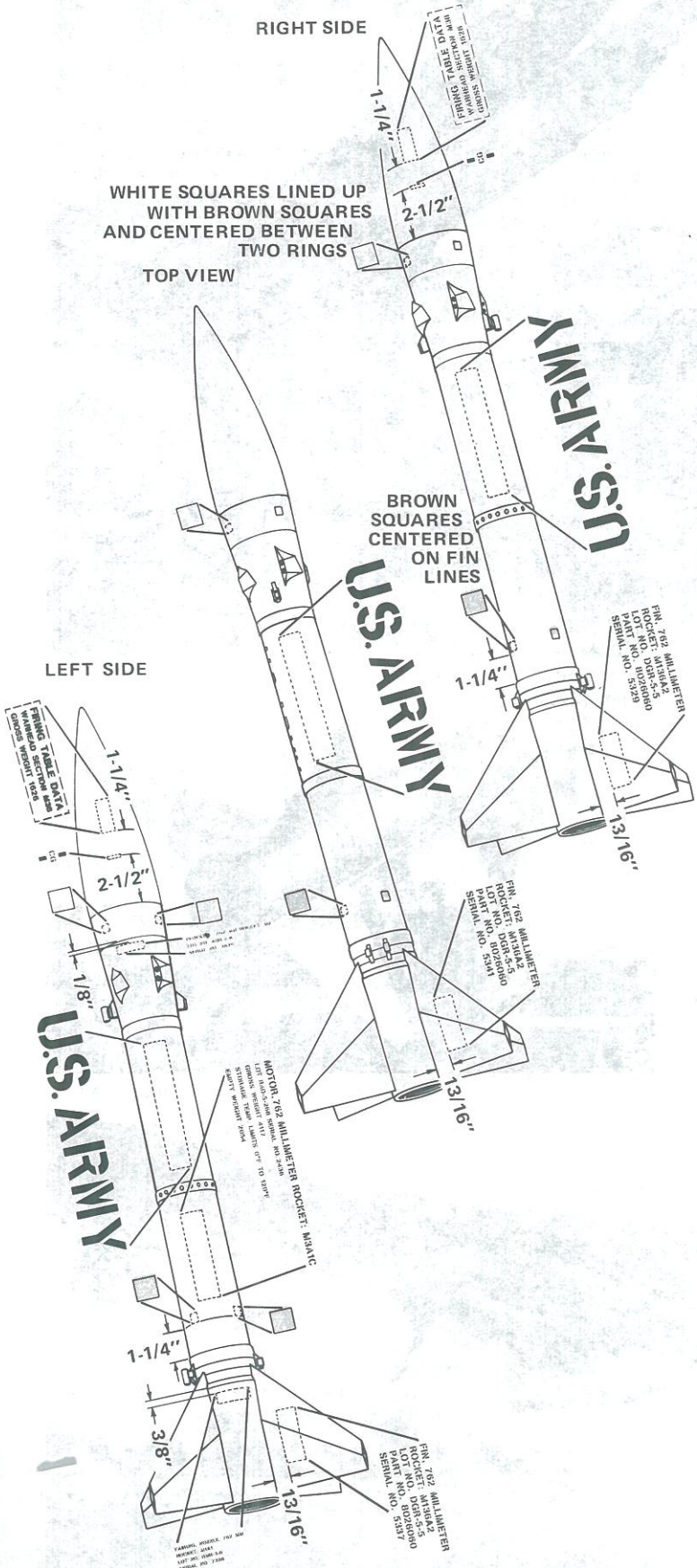

38 Refer to decal placement drawings and apply decals.

COUNTDOWN CHECKLIST

13 Pack 12 to 14 squares of loosely crumpled Estes RP-1A recovery wadding into main body tube. The wadding should fill the bottom of the parachute compartment for at least two inches.

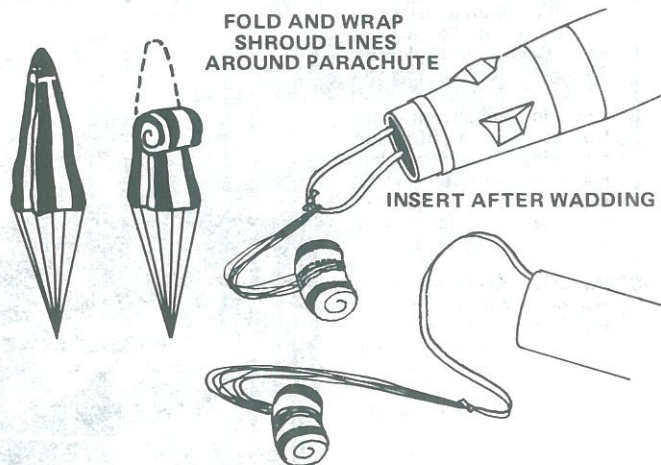

12 Loosely fold the main parachute and lay it on top of the wadding, with its shroud lines and shock cord on top of it. Fold and pack the parachute for the nose cone on top of the main chute. Slide the nose cone into place.

NOTE: DO NOT pack parachutes until you are actually ready to launch. For maximum parachute reliability, lightly dust the parachutes with ordinary talcum powder before each flight, especially in cold weather.

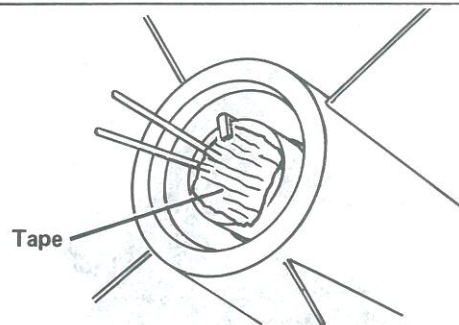

11 Install an igniter in a D12-3 engine as directed in the engine instructions. Insert engine into the engine mount. Make sure the engine hook latches securely over the end of the engine.

10 Disarm the launch panel.

9 Lower the rocket into position on the launch rod (a 3/16" diameter launch rod is recommended). Clean the micro-clips and attach one to each lead of the igniter. The clips must not touch each other, and the igniter leads must not cross.

8 Clear the launch area, alert recovery crew and trackers.

7 Check for low flying aircraft and unauthorized persons in recovery area.

6 Arm the launch panel.

5 - 4 - 3 - 2 - 1 LAUNCH !!

MISFIRE PROCEDURE

Occasionally the igniter will heat and burn in two without igniting the engine. This is almost always caused by a failure to install it correctly. Disarm the launch panel, remove the model, clean the igniter residue from the nozzle, and install a new igniter. Follow the launching procedure again.



1295 H Street
Penrose, CO 81240

www.estesrockets.com

U.S. ARMY

HONEST JOHN

BALLISTIC MISSILE

#2166

Congratulations, you have purchased a Classic kit from Estes! We have tried to keep this kit as close to the original 1975 version of the Honest John as possible. For your enjoyment we've enclosed the original version of the 1975 instructions. Over the years, several features have been improved and the changes are shown in this document. Use the original instructions as well as this document to build your model.

PARTS AND SUPPLIES

The following items have been updated since the initial release of the Honest John:

C) Launch Lug LL12 CF	P/N 38166
F) Plastic Fin Sheet PF-69 (2)	P/N 32865
J) Body Tube BT-52S - Black	P/N 30386
J) Shock Cord (1/4" x 36")	P/N 38382
K) Shock Cord (1/4" x 18")	P/N 38380
L) Set of 6 Tape Discs TD-144	Deleted
M) Shroud Line	Deleted
N) 24 in (61cm) Parachute (Ready-to-Fly)(2)	P/N 35803
P) Engine Hook EH-2A	P/N 35021
S) Engine Casing (Replaced by D-Engine Spacer ET-6)	P/N 35004
U) Balsa (1/8" x 3" x 3")	P/N 32121
V) Adhesive Capsule	Deleted



You will also need: White or yellow glue and contact cement instead of the adhesive capsule. Included are Ready-to-Fly parachutes.

Step 4 Place the slotted centering ring on the forward end of the stuffer tube. The stuffer tube must extend 1/16" past centering ring. Glue securely in place and allow to dry. Apply a second layer of glue to joints for strength.

Use hobby knife to cut out decals inside the dashed line. Use the following instructions instead of the Countdown Checklist on the original instructions.

Step 28 Use contact cement for this step.

PREPARE PARACHUTES FOR FLIGHT

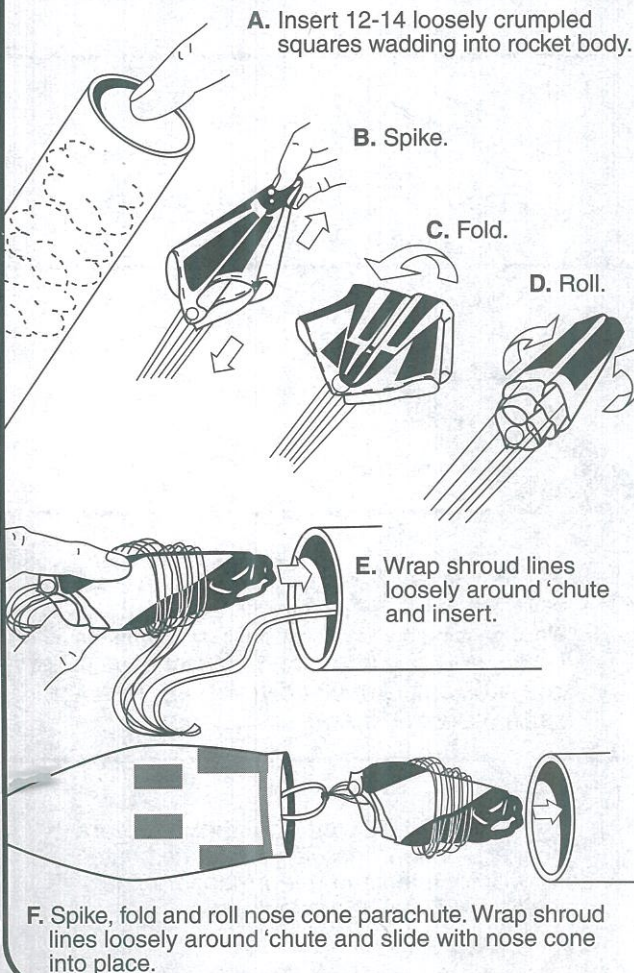

PREPARE ENGINE

Use the following in place of the 'PREPARE ENGINE' step on page 4.

WARNING: FLAMMABLE

Before proceeding read instructions & NAR Safety Code included with engines.

PREPARE YOUR ENGINE **ONLY** WHEN YOU ARE **OUTSIDE** AT THE LAUNCH SITE PREPARING TO LAUNCH!

If you do not use your prepared engine, remove the igniter before storing your engine.

A. Separate igniter and plug.

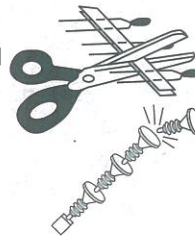

B. Hold engine upright, drop in igniter so tip touches propellant. Do NOT bend!

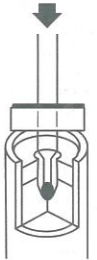

C. Insert plug.



D. Press firmly.

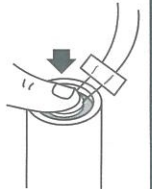

E. Bend igniter wire back and form leads.

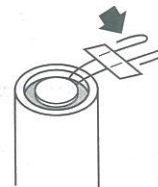

F. Insert engine. Engine hook will lock engine in place.

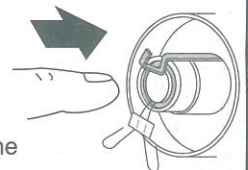

See the back of this page for Launch Supplies, Countdown and Launch instructions and Misfire Procedure.

LAUNCH SUPPLIES:

- Launch Pad (Estes Porta-Pad® II)
 - Launch Controller (Estes Electron Beam®)
 - Recommended Estes Engines: D12-3 only
 - Estes Recovery Wadding (EST 302274)
 - Igniters and igniter plugs (included with Estes engines)
 - Estes Maxi™ Launch Rod (EST 302244)
- Use only Estes products to launch this rocket.

TIPS FOR LAUNCHING YOUR ROCKET

- Choose a large field away from power lines, buildings, tall trees, and low flying aircraft. Try to find a field at least 500 feet (152.4 meters) square. The larger the launch area, the better your chance of recovering your rocket.
- Launch area must be free of dry weeds and brown grass.
- Launch only during calm weather with little or no wind and good visibility.
- Don't leave parachutes packed more than a minute or so before launch during cold weather (colder than 40° Fahrenheit [4° Celsius]).
- Always follow the National Association of Rocketry (NAR) MODEL ROCKETRY SAFETY CODE while participating in any model rocketry activities. The safety code is enclosed with this kit.

COUNTDOWN AND LAUNCH

10... Make sure the safety key is **not** inserted in the launch controller.

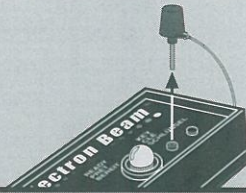

9... Remove the safety cap from the launch rod. Slide the rocket's launch lugs down the launch rod. Rocket should slide freely.



8... Attach clean micro-clips on the igniter wire leads. Clips must not touch each other, the launch rod or the metal blast deflector.

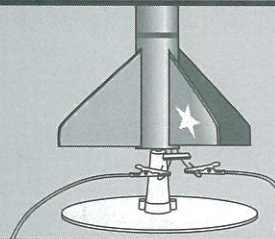

7... Move everyone 15 feet (5 meters) from your rocket (launch wire length).

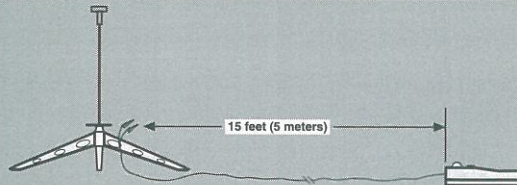

6... Insert safety key. Press the safety key in until bulb glows and keep holding during the countdown and launch. **NOTE:** The engines can only be ignited when the safety key is held down.

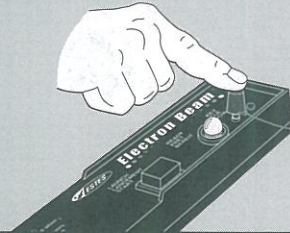

5... Start audible countdown.

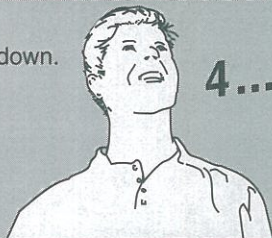

4...3...2...1...

LAUNCH!

While pushing the key down, push launch button until the engine ignites. **IMMEDIATELY REMOVE THE SAFETY KEY FROM THE LAUNCH CONTROLLER. REPLACE THE SAFETY CAP ON THE LAUNCH ROD.**

MISFIRES

When an ignition failure occurs, **remove the safety key** from the launch control system and **wait one minute before approaching the rocket.** Remove the expended igniter from the engine and install a new one. Be certain the coated tip is in direct contact with the engine propellant. Broken or chipped coating will not affect the performance of the igniter. Reinstall the igniter plug as illustrated previously. Repeat the countdown and launch procedure.

HONEST JOHN LAUNCH SEQUENCE

- A. Honest John is raised into launch position aboard mobile carrier at U.S. Army's Fort Carson in Colorado Springs, Colorado.
- B. Now in launch position, Honest John is all ready for firing. If this is a test maneuver, rocket is armed with a pyrotechnic warhead identified by the white squares on nose cone.
- C. View of Honest John's fin assembly shows huge exit throat diameter of nozzle. Rocket's exhaust will scorch the ground for several hundred yards to the rear of the mobile carrier.
- D. At only 75 yards from the mobile launch pad, the ground rumbles with the sound and shock waves created by the rocket's incredibly quick lift-off. Streaking downrange to its target, the Honest John is visible for only a few seconds. The launch is felt as much as seen, according to reports from most spectators.

