

After removing rocket from guide, apply glue fillets to all joints. Smooth each fillet with finger.

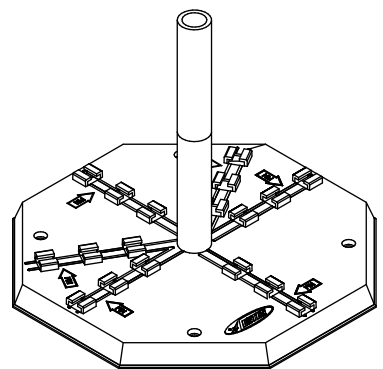

If building a rocket with swept-back fins, tape an expended Standard casing (not included) onto the end of supplied Standard casing to form a longer core. Slide engine rocket body over double stacked Standard casings and glue fins in place.

For BT-50 body tubes or 24 mm D/E engine mounts or if extra length is needed, tape an expended D/E casing (not included) onto the end of supplied D casing to form a longer core. Slide engine rocket body over double stacked D casings and glue fins in place.

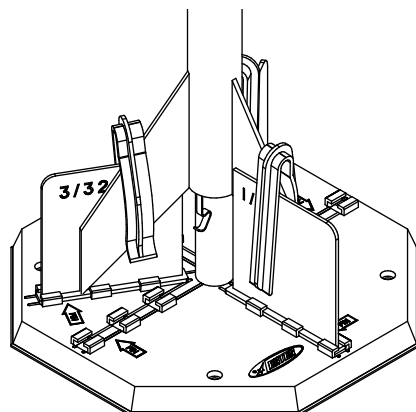
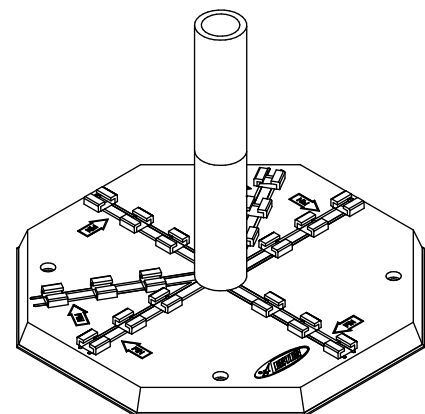
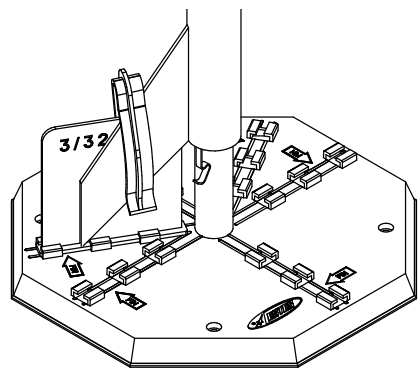

Made at  
Estes-Cox Corp.  
1295 H Street, PO Box 227  
Penrose, CO USA  
81240-0227

# FIN ALIGNMENT GUIDE

## GUÍA PARA ALINEAR LA ALETA

## GUIDE D'ALIGNEMENT DES AILERONS

#302231

www.  
**estes**  
rockets  
.com

**IMPORTANT:** Your Estes product is marked with a four digit lot code. The code is two digits, a / and two more digits representing the month and year of manufacture, respectively. **Please record the lot code found on the base and keep for future reference. Lot code: \_\_\_\_\_**

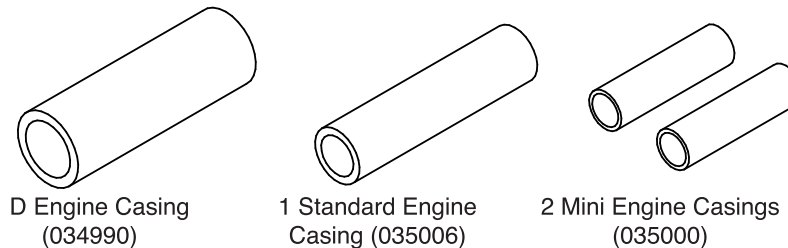

### SUPPLIES



MODELING KNIFE/  
NAVAJA DE PRECISION/  
COUTEAU DE  
MODELAGE



FINE SANDPAPER

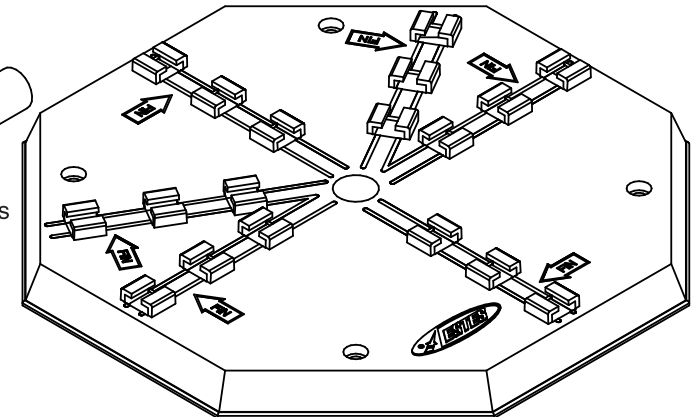
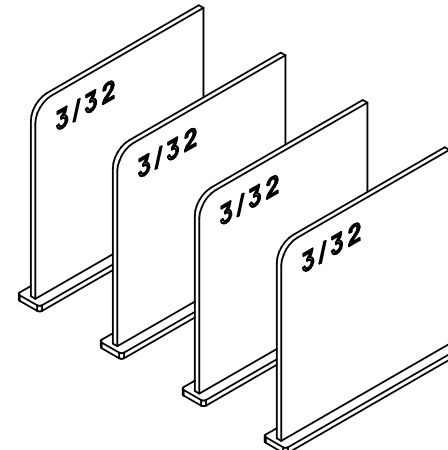

1 Alignment Guide Base (033068)

4 Fin Clips (033068)

The Fin Alignment Guide operates on the following principle: the rocket body is centered on the base via a core arrangement consisting of three different engine casing sizes. These casings correspond to the three sizes of model rocket engines now available: Mini, Standard and D. Fins are attached by clamping against brackets which are accurately aligned with the core. The core is a Mini casing which fits the hole in the base. This guide will accommodate body tube sizes up to BT-101 (3.983" – 101.2 mm).

### PREPARATION OF THE FIN ALIGNMENT GUIDE

The engine casings are designed to easily slip into engine mount tubes.

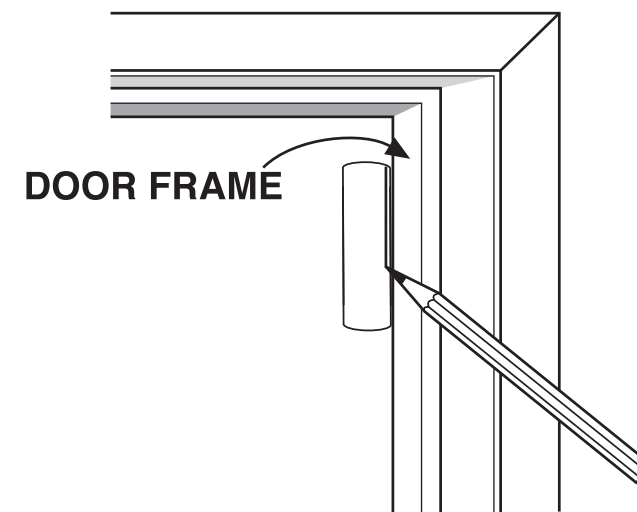

For one Mini casing and the Standard and D casings, draw a line the length of each casing, using a door frame as a straight edge.

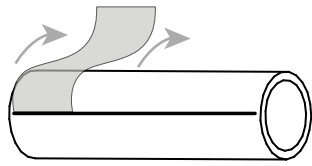

**Mini Casing** - Apply clear tape to marked casing with edge of tape exactly on pencil line. Carefully wrap tape around casing and cut tape at pencil line. Smooth tape down and continue to apply rings of tape to one end of the Mini casing until the casing is a snug fit in a BT-5 body tube. **Do not** apply tape to the opposite end of this Mini casing as it must fit into the guide base. **Do not** apply tape to other Mini casing as it is used as the core when using the Standard and D casings.

**Standard and D Casings** - Apply clear tape to casing with edge of tape exactly on pencil line. Carefully wrap tape around casing and cut tape at pencil line. Smooth tape down and continue to apply rings of tape to both ends to provide for a snug fit.

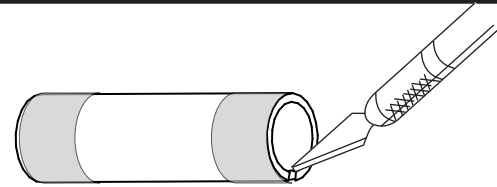

Using a hobby knife, cut away a small portion of the inside edge (both ends) of the Standard and D casings.

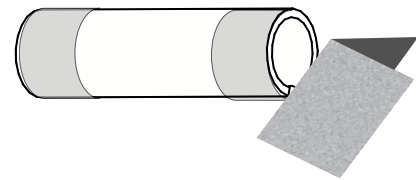

Sand the edges on both ends of the Standard and D casings. This provides a "lead in" for slipping one casing inside another.

**USING THE FIN ALIGNMENT GUIDE**

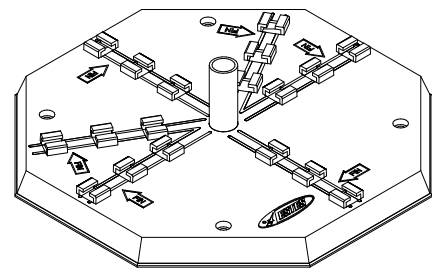

Insert Mini casing without tape into base. Casing should fit snugly to provide good vertical alignment. If casing is a tight fit, do not force it into hole. Lightly sand sides of casing until it can be inserted snugly in hole. If casing fits loosely, wrap short pieces of tape around casing until a snug fit is obtained. This casing is the core for assembly of any Standard to D engine powered rocket.

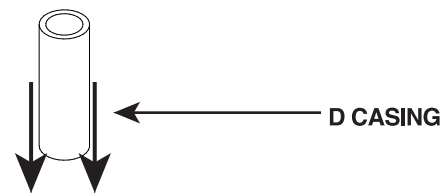

**D CASING**



**STANDARD CASING**

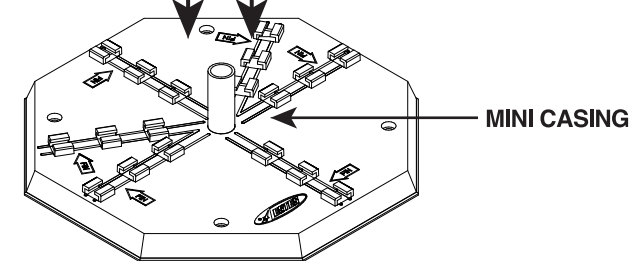

**MINI CASING**

If building a standard engine rocket, slide Standard casing over the Mini casing. For a D engine rocket, slide D casing over Standard Casing.

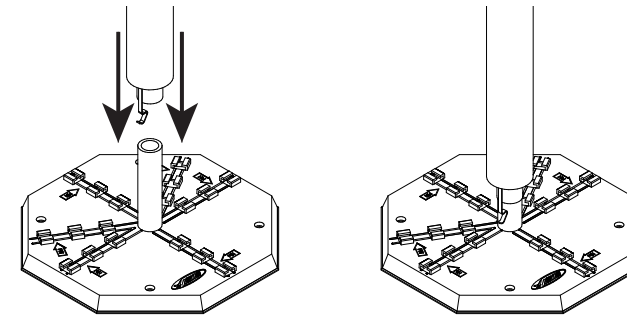

If rocket body is larger in diameter than casing size, then engine mount must be assembled into body tube prior to fitting onto guide. Push engine hook outward to allow mount to slide down over casing.

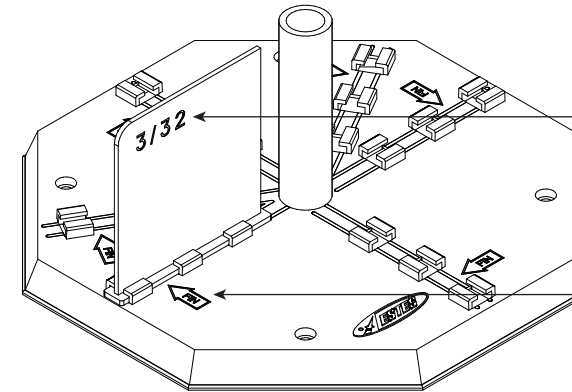

3/32 balsa fin side

Bracket arrow

**Fin Brackets**

- Base is designed to accommodate either 3 or 4 fin configurations. Brackets are inserted into the appropriate set of slits. NOTE: the brackets fit snugly into the slots.
- Brackets are designed for use only with 3/32" (2 mm) or 1/8" (3 mm) thick balsa fins only. Balsa fin is always placed to the right side of bracket (looking toward center of base).
- Example - if building a rocket using 3/32" (2 mm) fins, insert the brackets into the base with the inscribed number 3/32 facing arrow.
- Brackets have one top corner rounded for a visual check of correct placement. In this example, all rounded corners will point away from center of base.
- To build a rocket with 1/8" (3 mm) thick fins, reverse the brackets.

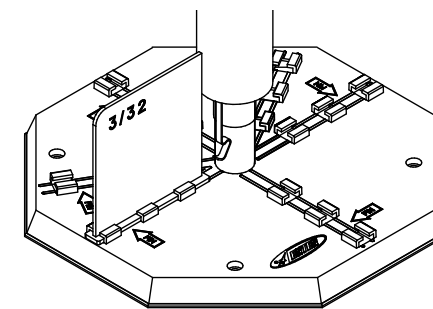

To glue a set of fins on a rocket, place body tube on core and insert brackets in slots. Leave a slight gap between the brackets and body tube.

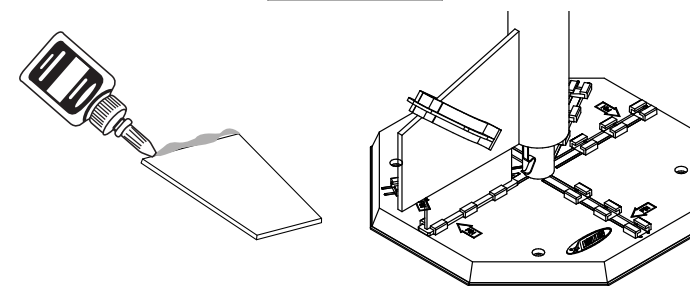

Apply a thin layer of glue to root edge of a fin. Allow to dry 1 minute. Apply a 2nd layer of glue and position the fin against bracket and press in place against body tube. Use clip to hold fin in place.

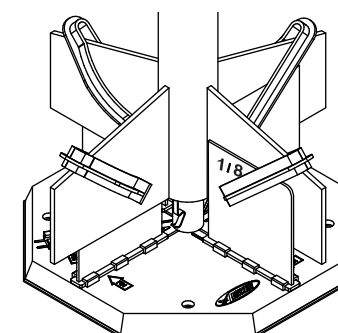

Repeat process with remaining fins. Allow fins to set at least one hour before removing rocket from guide.