

RECOVERY SYSTEM ATTACHMENT

1. Form loop with shroud lines.
2. Insert loop through **J**.
3. Pass **P** through loop.
4. Pull lines tight.
5. Tie **L** to **J** with double knot.

FLIGHT RECOVERY PREPARATION

NOTE: Only Estes Recovery Wadding (302274) recommended.

1. Pull shock cord taut when inserting wadding.
2. Insert 5 - 6 loosely crumpled squares recovery wadding. Push below shock cord attachment.
3. Spike.
4. Fold.
5. Roll.
6. Wrap lines loosely around parachute. Insert parachute and shock cord into body tube.

NOTE: Recovery wadding and parachute must slide easily into body tube. If too tight, redo.

ENGINE PREPARATION

WARNING: FLAMMABLE

To avoid serious injury, read instructions & NAR Safety Code included with engines. **PREPARE ENGINE ONLY WHEN YOU ARE OUTSIDE AT THE LAUNCH SITE PREPARING TO LAUNCH!** If you do not use your prepared engine, remove the igniter before storing engine.

1. Separate igniter and igniter plug.
2. Insert igniter.
3. Insert plug.
4. Push down.
5. Gently bend igniters to form leads as shown.
6. Insert engine into rocket.

COUNTDOWN AND LAUNCH

KEY ALWAYS OUT UNTIL FINAL COUNTDOWN!

- 1... Masking Tape
- 2...
- 3...
- 4... 15 FT. (4.6 M)
- 5... WHILE HOLDING KEY DOWN FIRMLY, PRESS LAUNCH BUTTON UNTIL LIFTOFF!

LAUNCH SUPPLIES (Sold Separately)

- Porta-Pad® II Launch Pad
- Electron Beam® Launch Controller
- Recovery Wadding
- Igniters (with Engines)
- Igniter Plugs (with Engines)
- Recommended Estes® Engines: B4-4, B6-4, C6-5

INSERT KEY. PUSH DOWN HARD. BULB WILL LIGHT.

LAUNCH BUTTON

4... 3... 2... 1...

PRECAUTIONS

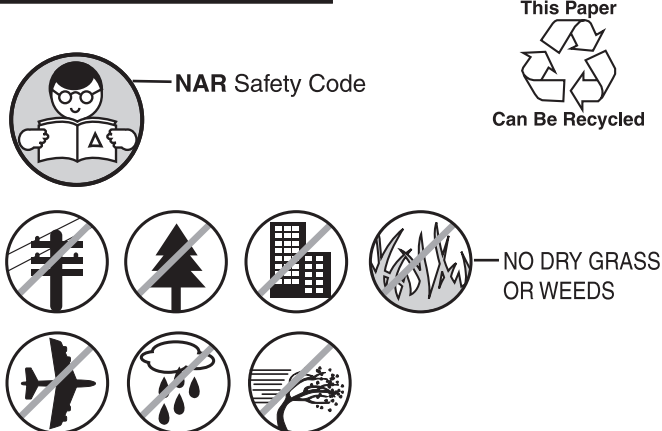

PRE-LAUNCH CHECK

For safety, never launch a damaged rocket. Check the rocket's body, nose cone and fins. Also, check the engine mount, recovery system and launch lug. Repair any damage before launching the rocket.

FLYING YOUR ROCKET

Choose a large field (500 ft. [152 m] square) free of dry weeds and brown grass. The larger the launch area, the better your chance of recovering your rocket. Football fields and playgrounds are great. Launch only with little or no wind and good visibility.

Always follow the enclosed National Association of Rocketry (NAR) SAFETY CODE.

MISFIRES

TAKE THE KEY OUT OF THE CONTROLLER. WAIT ONE MINUTE BEFORE GOING NEAR THE ROCKET! Disconnect the igniter clips and remove the engine. Take the plug and igniter out of the engine. If the igniter has burned, it worked but did not ignite the engine because it was not touching the propellant inside the engine. Put a new igniter all the way inside the engine without bending it. Push the plug in place. Repeat the steps under Countdown and Launch.



Estes-Cox Corp.
1295 H Street, PO Box 227
Penrose, CO 81240-0227
Printed in China

PHOENIX BIRD™

FLYING MODEL ROCKET KIT INSTRUCTIONS

KEEP FOR FUTURE REFERENCE

#3024

ASSEMBLY TIP:
Read all instructions before beginning work on your model. Make sure you have all parts and supplies.

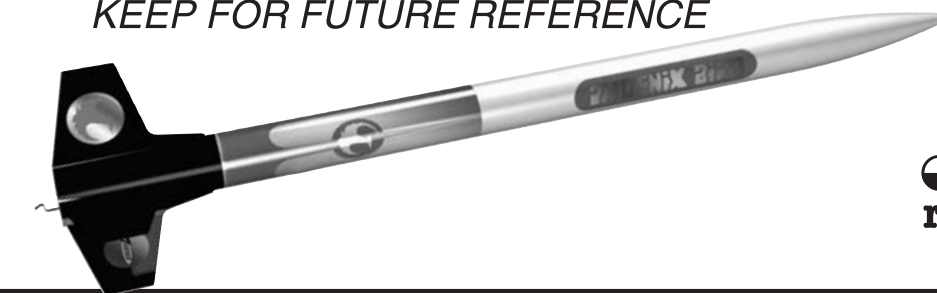

www.estesrockets.com

NOTE: Test fit all parts together before applying glue. If parts don't fit properly, sand as required for precision assembly.

Part	Qty.	Description	Part Number
A	1	Engine Tube	030326-1
B	1	Engine Hook	035021
C	1	Engine Hook Retainer Ring (mylar)	030168
D	1	Engine Block	030224
		Laser Cut Centering Ring Set Includes	030125
E	1	Centering Ring Notched	
F	1	Centering Ring	
G	1	Slotted Body Tube 12" (30.5 cm)	031782
H	1	Balsa Nose Block	070162
I	1	Upper Body Tube 7" (178 mm)	030454
J	1	Screw Eye	038251
K	1	Balsa Nose Cone	070276
L	1	Shock Cord 30" (76 cm)	038369
M	2	Launch Lug	038176
		Laser Cut Balsa Sheet Includes	065898
N	4	Laser Cut Fin	
O	4	Laser Cut Sub Fin	
P	1	Parachute 18" (46 cm)	035816
	1	Self-Stick Decal	065899

SUPPLIES

In addition to the parts included in the kit you will also need:

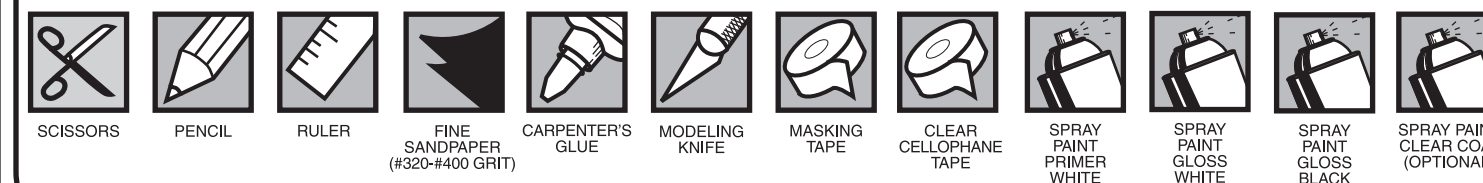

TUBE MARKING GUIDE AND SHOCK CORD MOUNT

(Make a copy if you want to keep instructions.)

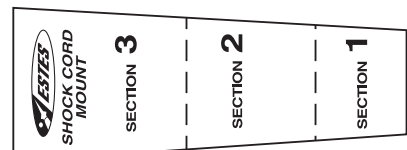
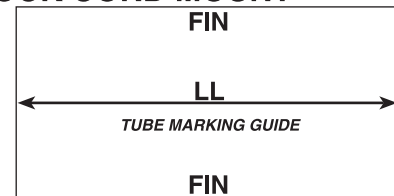

FIN PREPARATION

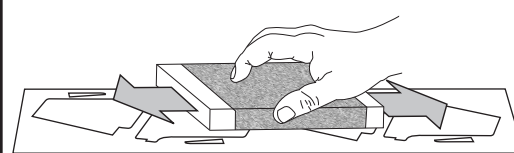

1. Sand both sides of balsa sheet with fine sandpaper (#320 or #400 grit).

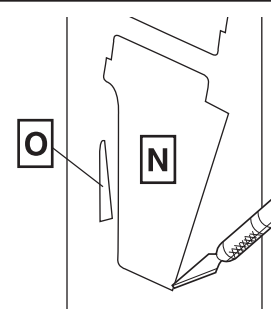

2. Cut **N** and **O** from sheet.

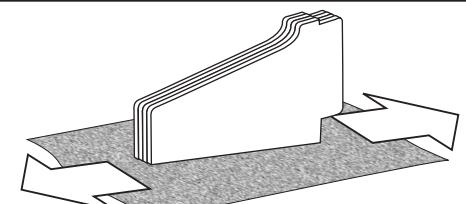

3. Stack like fins together. Sand edges smooth.

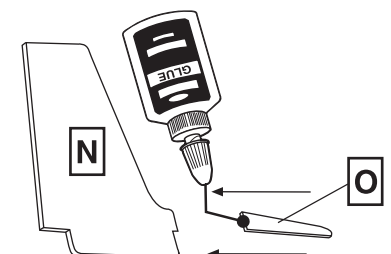

4. Glue **O** to **N**. Let dry. Repeat for each fin.

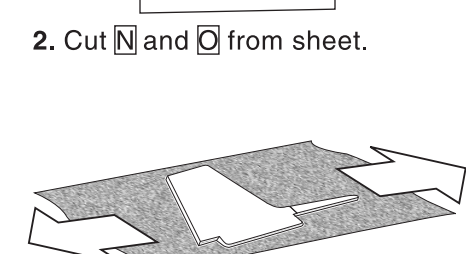

5. Lay each fin assembly flat and smooth with sanding block.

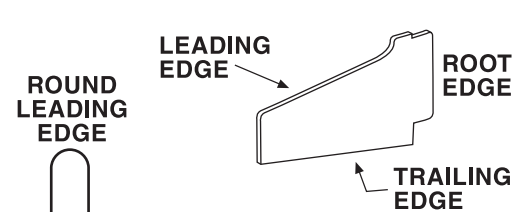

6. Sand leading edges round. **DO NOT** round root edges.

ENGINE MOUNT ASSEMBLY

NOTE: For the assembled fins to fit properly, it is very important to measure, mark and assemble the ENGINE MOUNT carefully.

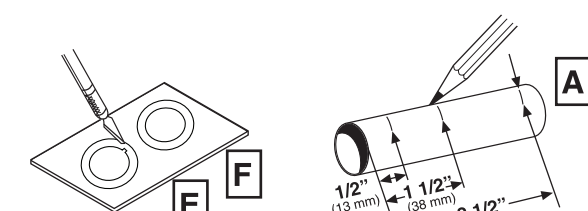

1. Remove **E** and **F**.

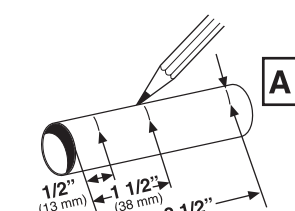

2. Measure and mark **A** as shown.

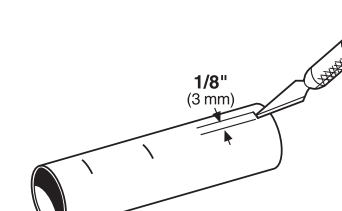

3. Cut small slit at mark.

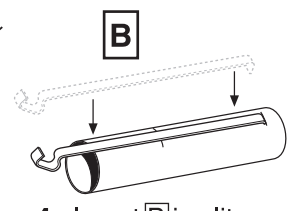

4. Insert **B** in slit.

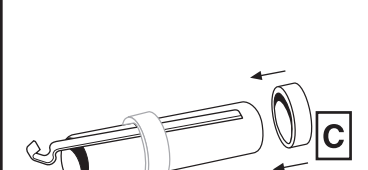

5. Slide **C** just past 1 1/2" (38 mm) mark.



6. Apply glue to both edges of **C**. Wipe excess glue. Let dry.

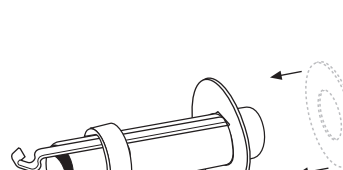

7. Slide **F** to **B**.

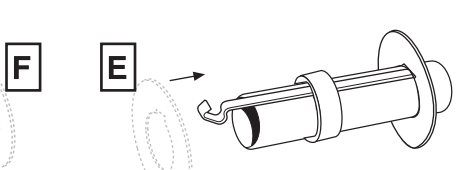

8. Slide **E** to 1/2" mark (13 mm).

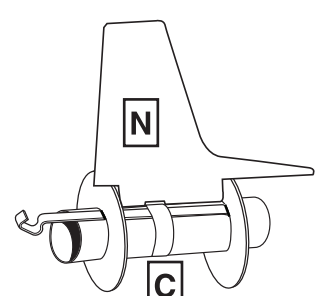

9. Test fit **N** over **C** before gluing.

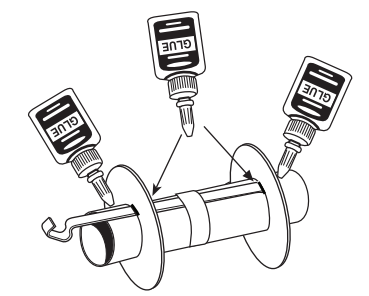

10. Apply glue to both sides of **E** and **F**. **Avoid applying glue to B at notch.** Let dry.

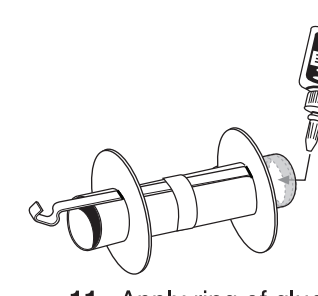

11. Apply ring of glue to inside end of **A**. Insert **D** until it stops. Let dry.

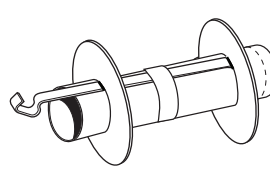

Complete Engine Mount Assembly

ENGINE MOUNT ATTACHMENT

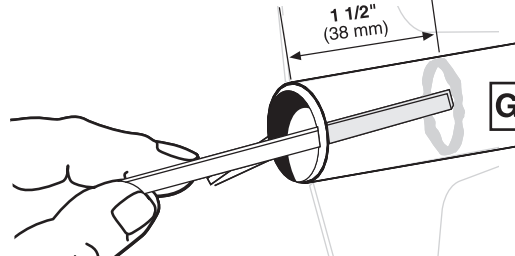

1. Apply ring of glue inside of **G**.

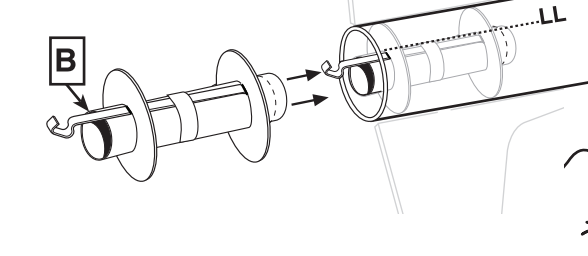

2. Align **B** with **LL** and slide engine mount assembly into **G** until tube ends are even.

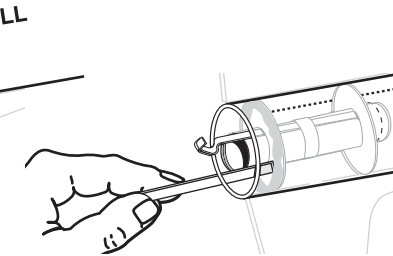

3. Apply ring of glue to inside of **G**. Let dry.

TUBE MARKING

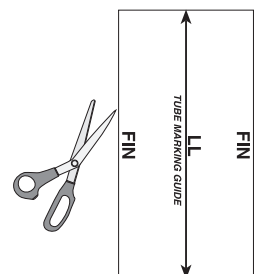

1. Cut tube marking guide from instructions.



2. Tape guide to between slots. Mark **LL** at arrows.

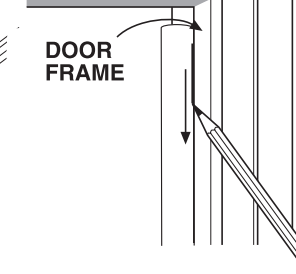

3. Remove guide. Use a door frame and extend **LL** entire length.

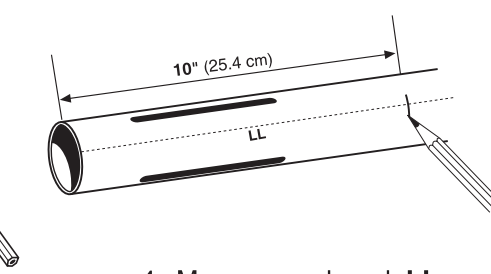

4. Measure and mark **LL** as shown.

FIN ATTACHMENT

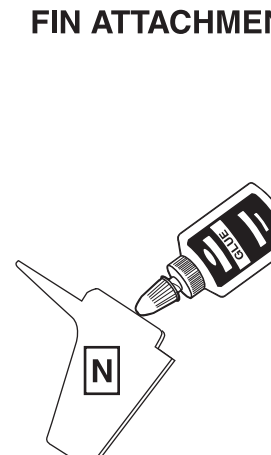

1. Apply glue to root edge of fin assembly. Let dry 1 minute. Apply 2nd layer of glue. Insert assembled fin into slot.

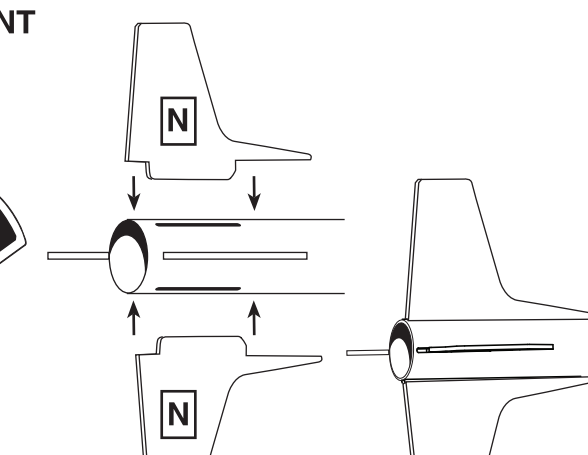

2. Repeat for remaining fin assemblies. Let dry.

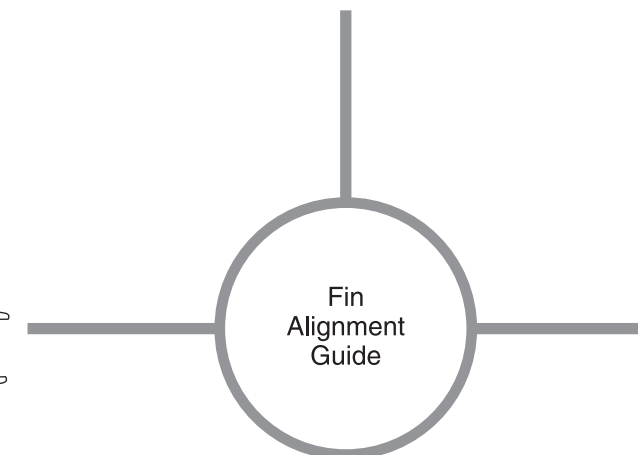

Fin Alignment Guide

Use fin alignment guide for fin attachment accuracy.

LAUNCH LUG ATTACHMENT

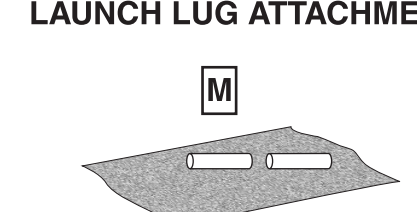

1. Sand both **M** with fine sandpaper.

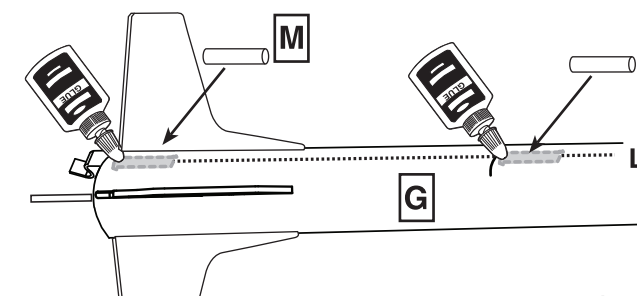

2. Apply glue to end of **G** on **LL**. Position **M** centered on **LL**. Let dry.

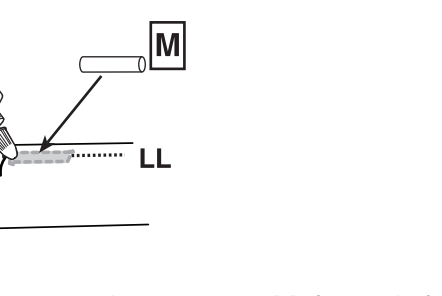

3. Apply glue on **LL** forward of mark. Position **M** centered on **LL** forward of mark. Let dry.

UPPER BODY TUBE ASSEMBLY

NOTE: you can permanently glue the nose cone in place or use upper stage as payload section by taping nose cone to upper section.

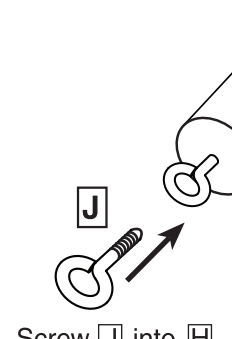

1. Screw **J** into **H**.

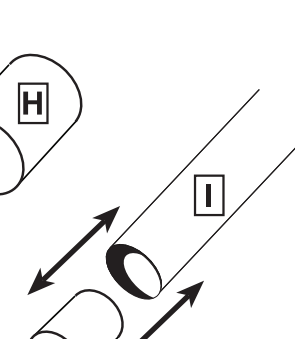

2. Test fit **H** in **I**. Sand as required.

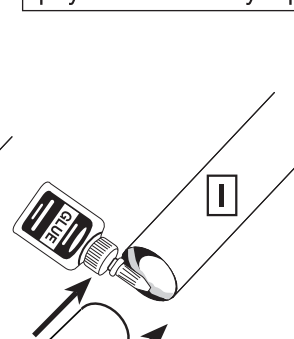

3. Apply glue to inside of **I**. Insert **H** half way. Let dry.

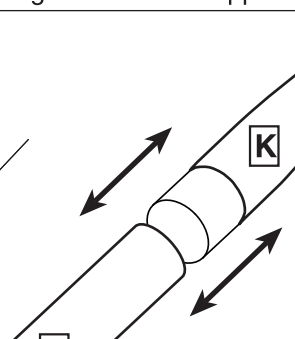

4. Test fit **K** in **I**. Sand as required for easy insertion.

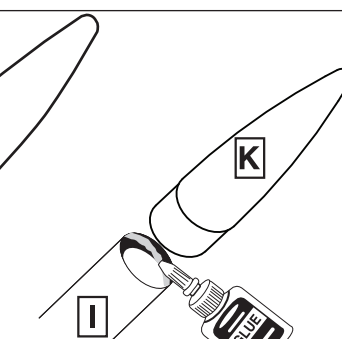

5. If making upper section permanent, apply ring of glue to inside of **I** and insert **K**. Wipe excess glue. Let dry.

SHOCK CORD INSTALLATION

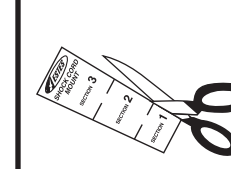

1. Cut shock cord mount from instructions.

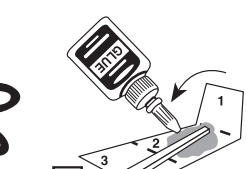

2. Apply glue to section 2. Place **L** on glue. Fold forward.

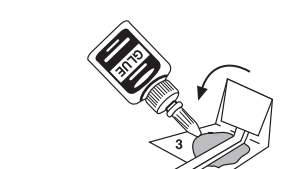

3. Apply glue and fold forward.

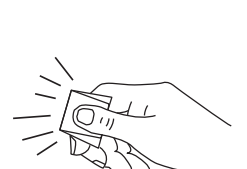

4. Squeeze tight!

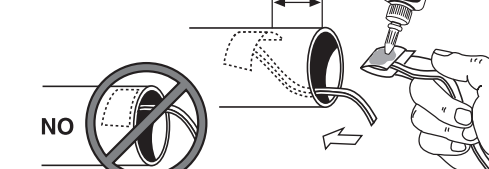

5. Apply glue to shock cord mount and insert in body tube. Hold until glue sets. Let dry.

ROCKET FINISHING

NOTE: We have found Testors spray primers (Testors #2948 White Primer), Testors One Coat Lacquer spray paints (color of your choice), Testors Model Master spray paints (color of your choice) and Testors Gloss Lacquer (#1961) to be excellent for providing a long lasting and durable finish on your rocket. Always be sure to spray your models outside or in a well ventilated area.

STEPS TO A QUALITY FINISH

1. Insert shock cord into body tube and hold in place with paper.
2. Lightly sand body tube, fins and nose cone with fine sandpaper (#320 or #400 grit).
3. Apply glue fillet to fins and launch lug joints.
 - a. Let glue to dry overnight.
4. Use a stick inserted into the engine tube end of the rocket for painting.
5. Hold the upper section by the screw eye with a clip or pliers for painting.
6. If using the upper section as a payload, insert a small nail into the base of the nose cone for painting.
7. We recommend a good filler/primer to be applied to the balsa fins and nose cone before painting.
8. Apply 1-2 light coats of primer to rocket body and nose cone, lightly sanding with fine sandpaper (#320 or #400 grit) between coats.
 - a. Let dry between each coat.
9. Apply gloss white to the upper and lower sections and the nose cone if separate.
 - a. Let paint dry overnight (24 hours is best).
10. Apply ring of masking tape above the fins.
11. Cover upper white paint with protective covering (plastic bag works well).
12. Spray bottom gloss black.
 - a. Let paint dry overnight (24 hours is best). Remove masking tape and protective cover.
13. Apply self-stick decals where shown.

