



EstesRockets.com

# TRI-FLYER

0647

AGES  
10+



Skill Level

**BEGINNER**

## MODEL ROCKET INSTRUCTIONS

### KEEP FOR FUTURE REFERENCE

**IMPORTANT:** Please record date found on decal and keep for future reference. \_\_\_\_\_

**READ ALL INSTRUCTIONS.** Make sure you have all parts and supplies. Test fit all parts before applying glue. Refer to your glue manufacturer's dry times during build.

### SUPPLIES



YELLOW GLUE



PLASTIC CEMENT



PENCIL

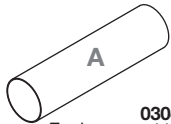

**030408**  
Engine mount tube



**030162-2**  
Engine block



**030164-2**  
Green adapter ring **x2**

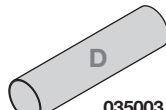

**035003**  
Yellow engine spacer tube



**030174-5**  
Red coupler

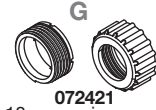

**072421**  
18mm engine retainer set



**072654**  
Nose cone pin

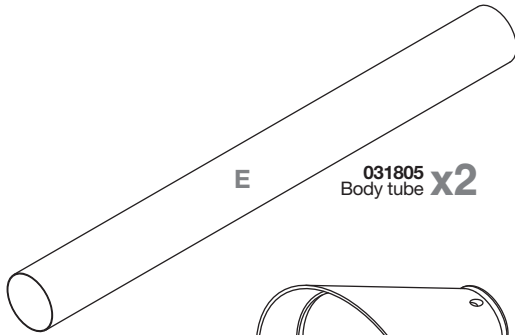

**031805**  
Body tube **x2**

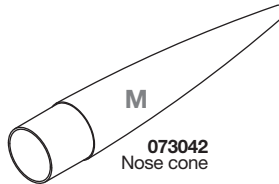

**073042**  
Nose cone

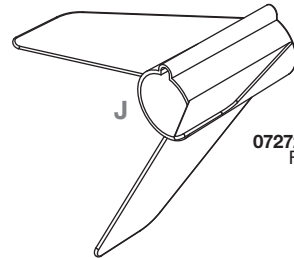

**072720**  
Fin



**072721**  
Fin ring

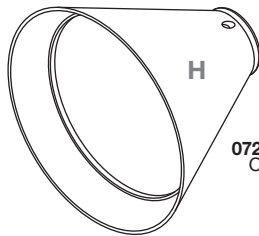

**072718**  
Cone

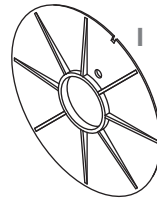

**072719**  
Cone ring

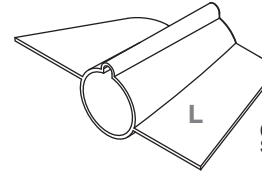

**072722**  
Spin fin



**072723**  
Spin fin ring

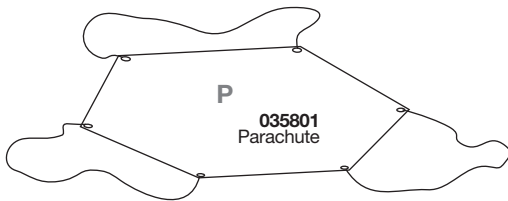

**035801**  
Parachute

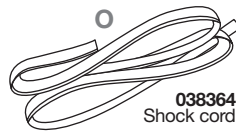

**038364**  
Shock cord

**090001A-0647**  
Self stick decals

**090001B-0647**  
Self stick decals



### ASSEMBLE ENGINE MOUNT

**1.** Make a pencil mark  $\frac{1}{4}$  in. from end of yellow engine spacer tube **D**.

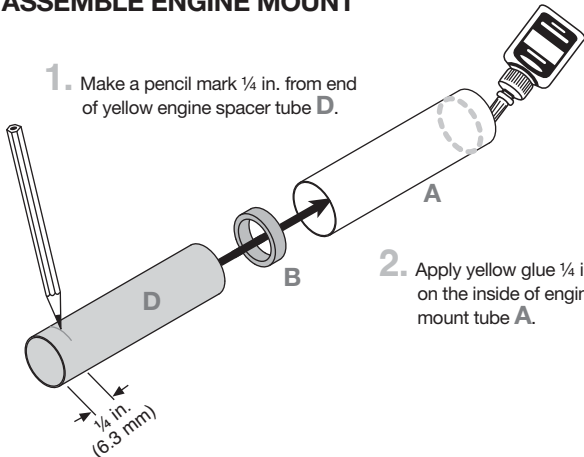

**2.** Apply yellow glue  $\frac{1}{4}$  in. on the inside of engine mount tube **A**.

**3.** Insert engine block **B** into engine mount tube **A**. Insert yellow spacer tube **D** up to the pencil mark to push the engine block in place.

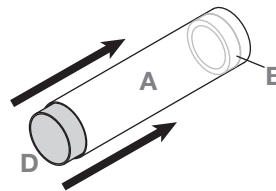

**4.** Quickly remove yellow spacer tube **D**.

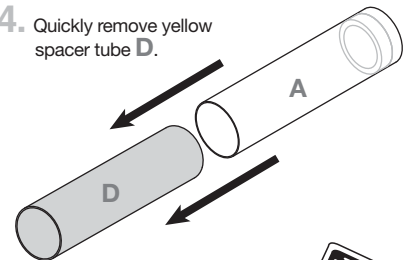

**5.** Apply yellow glue  $\frac{1}{4}$  in. from end of engine tube **A**.

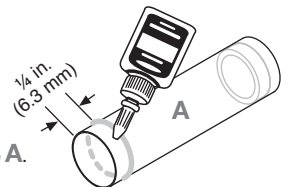

## ASSEMBLE ENGINE MOUNT (continued)

6. Place green adapter ring **C** onto the end of engine tube **A** using engine retainer **G** (notched side facing towards engine tube) to set the distance.

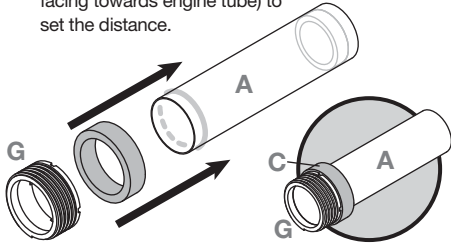

7. Remove engine retainer **G**.

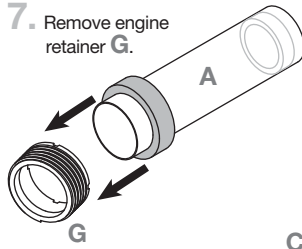

8. Apply yellow glue to the end of engine tube **A**, that has the engine block.

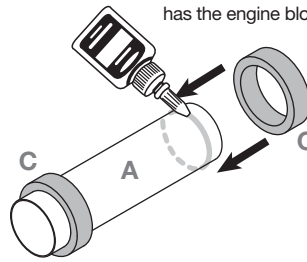

9. Place the other green adapter ring **C** onto the end of engine tube **A**.

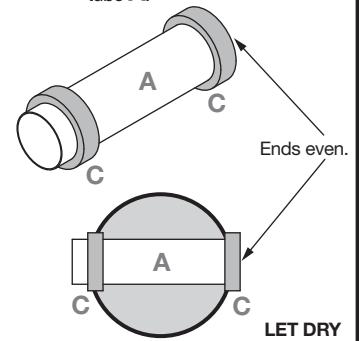

## ASSEMBLE BODY

1. Apply yellow glue to inside of body tube **E**. If need be, use a stick to apply glue 2 in. deep.

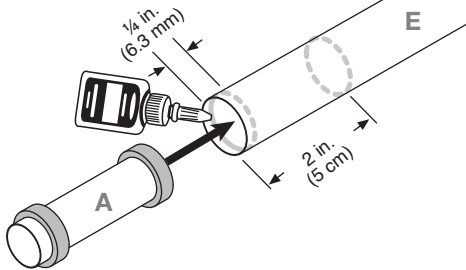

2. Insert engine mount assembly into body tube **E**. Ensure that the end of the green adapter **C** is even with the end of body tube **E**.

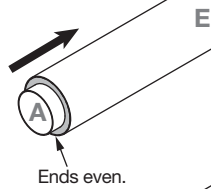

3. Apply yellow glue to inside of the opposite end of body tube **E**.

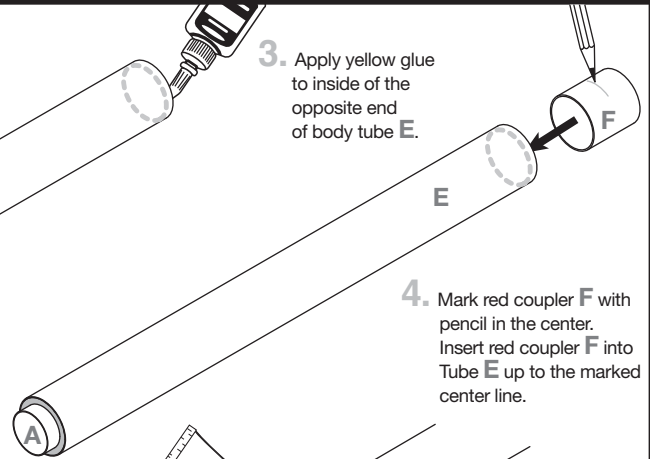

4. Mark red coupler **F** with pencil in the center. Insert red coupler **F** into Tube **E** up to the marked center line.

5. Apply yellow glue to the inside of the second body tube **E**. Insert red coupler **F** into second body tube **E**. Fit both body tubes together tightly.

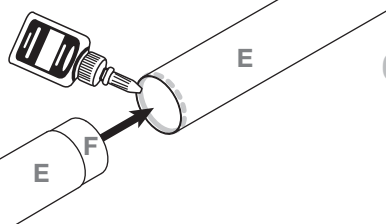

6. Apply plastic cement to the end of engine mount tube **A**. Place engine retainer **G** onto engine mount tube **A**, notched end facing body tube.

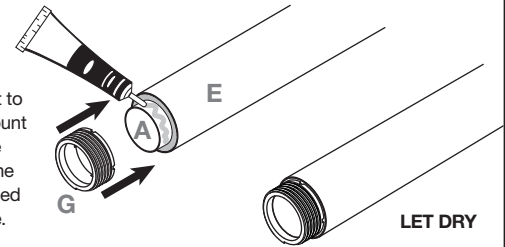

## ASSEMBLE NOSE CONE

1. Apply plastic cement to inside of nose cone **M**.

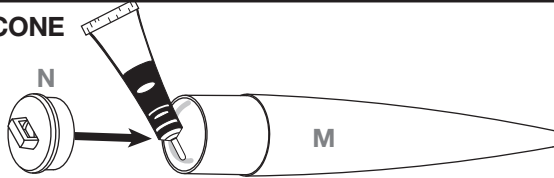

2. Insert nose cone pin **N** nose cone **M**.

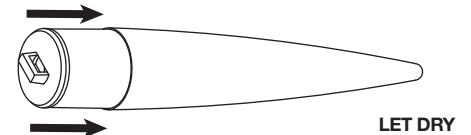

## INSTALL SHOCK CORD / PARACHUTE ATTACHMENT

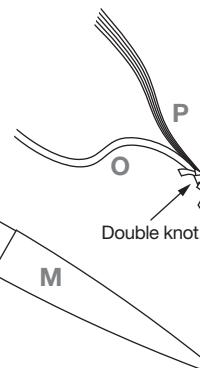
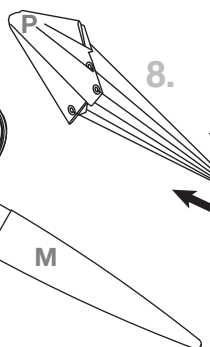
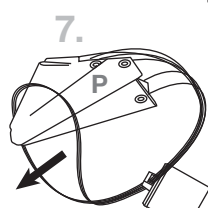
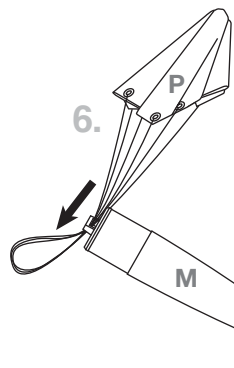
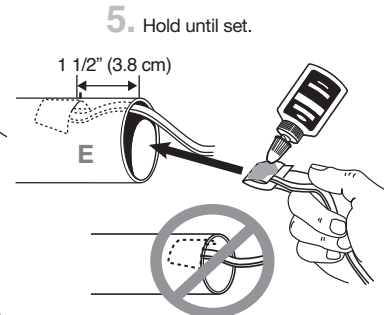
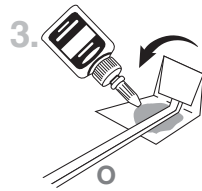
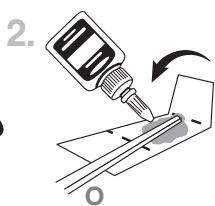
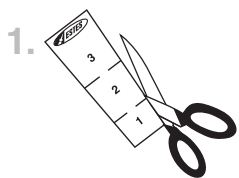

9. Tie other end of shock cord **O** to nose cone pin **N**, using a double knot.

### Shock cord mount:

Make a copy if you want to keep instructions.



3

2

1

## FIN OPTION PREPARATION

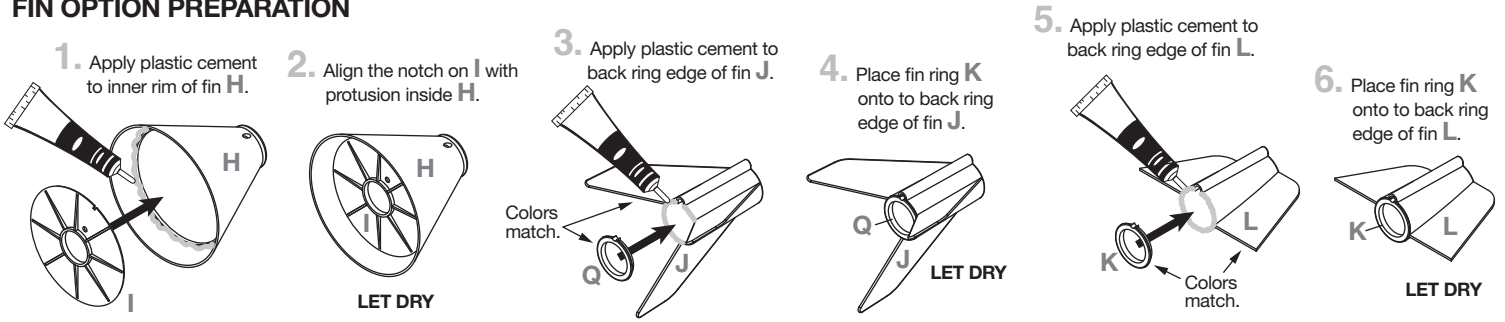

## TEST FIT FIN OPTIONS

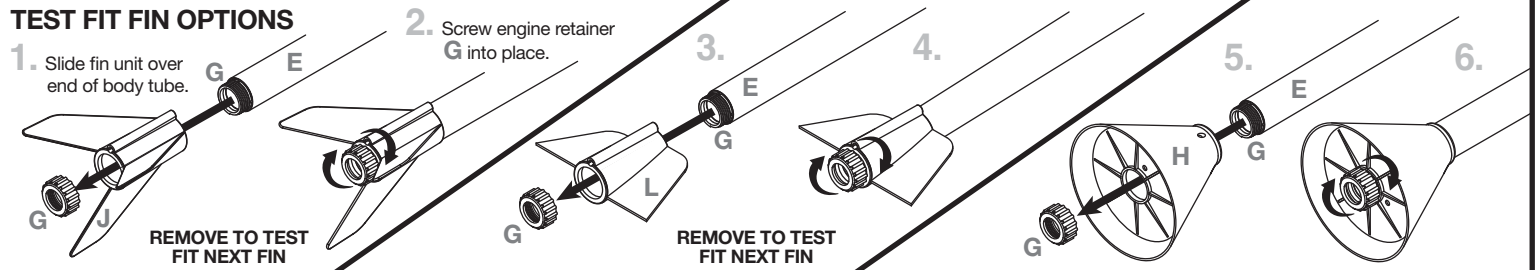

## APPLY STICKERS

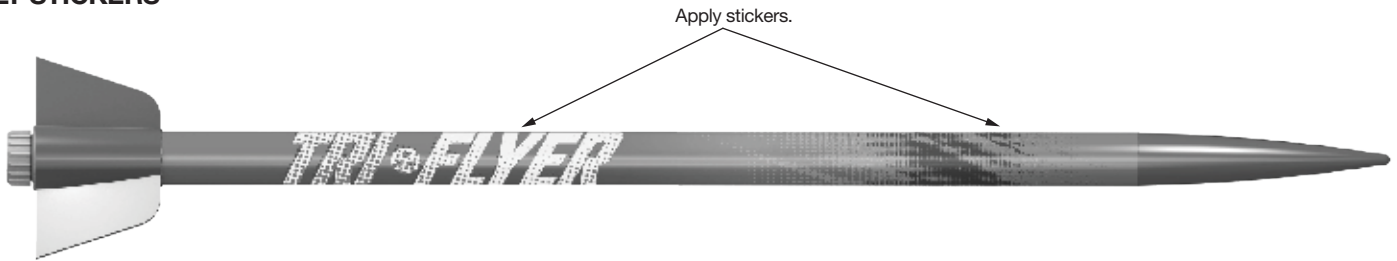

## PREPARE FLIGHT RECOVERY

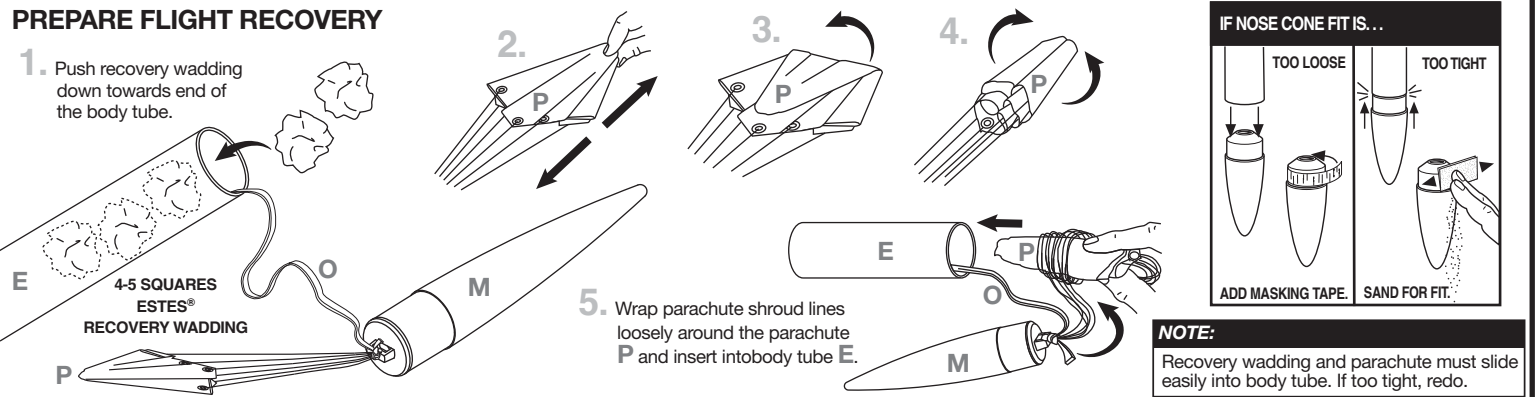

## PREPARE ENGINE

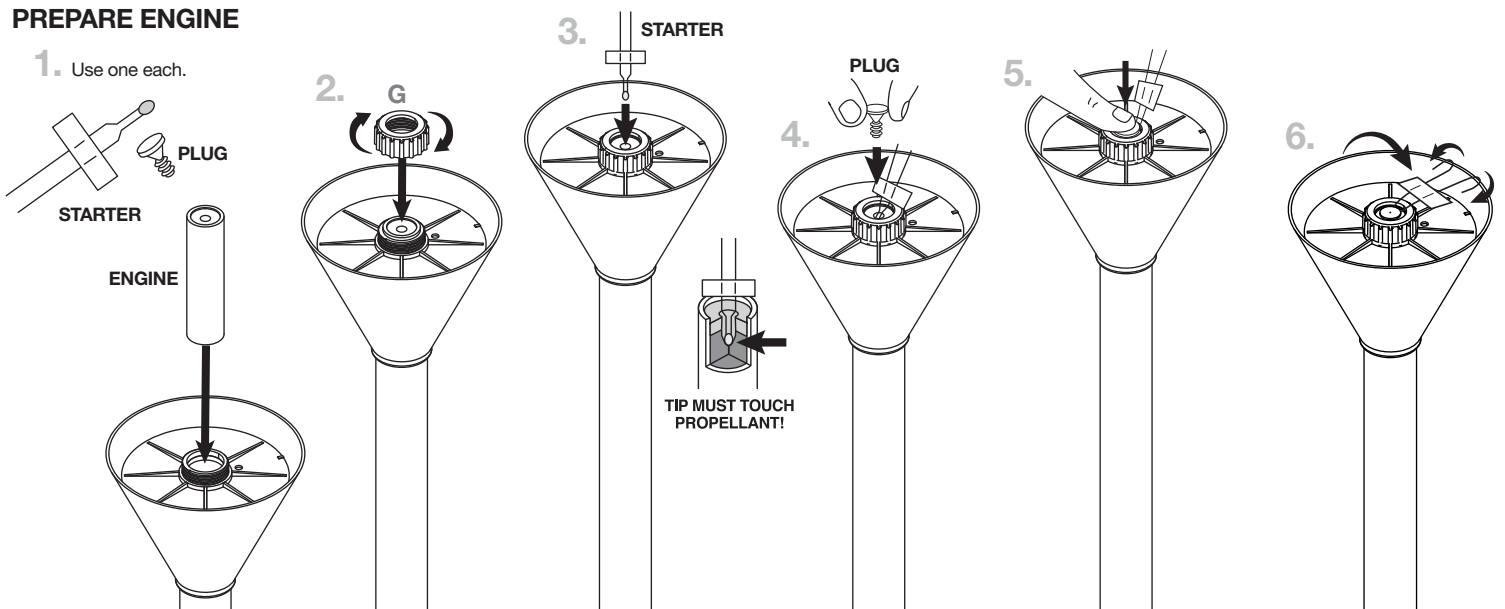

# COUNTDOWN AND LAUNCH

**NOTE:**

Always keep the key **OUT** until final countdown.

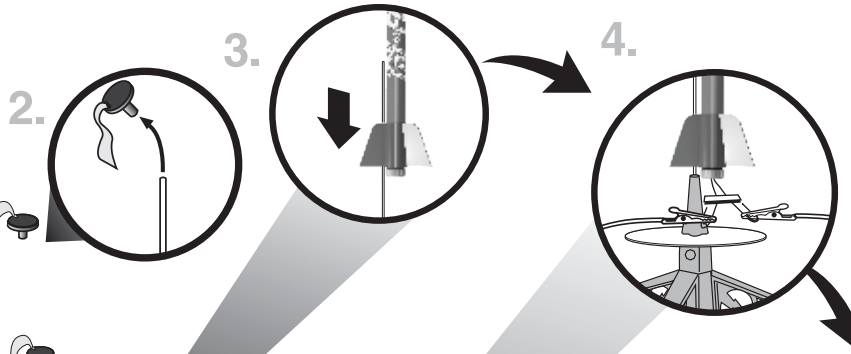

5. Fully extend your launch controller wire before launching.

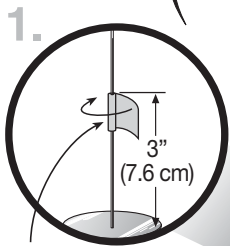
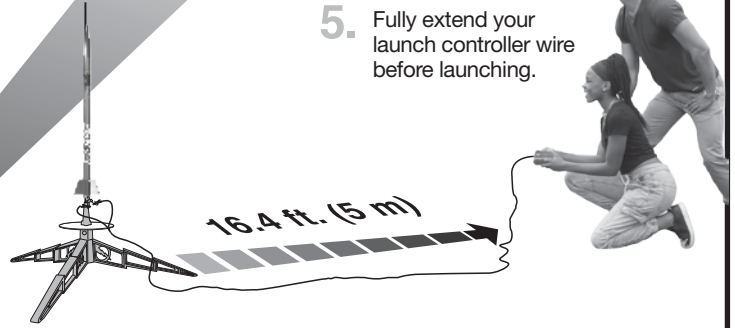

**MASKING TAPE**

**KEY**

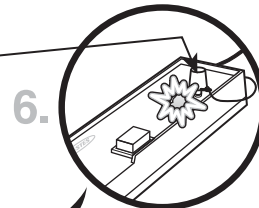

Insert key, push down hard. Bulb will light.

10.

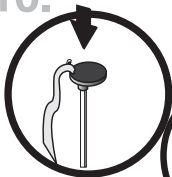

9.

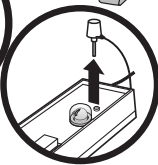

8.

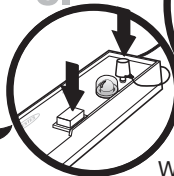

7.



While holding key down **FIRMLY**, press launch button until **LIFTOFF!**

**NOTE:**

Estimated weight:  
 With cone fin: 2.4 oz. (68 g)  
 With tri fin: 1.98 oz. (56.1 g)  
 With spin fin: 1.9 oz. (53.9 g)

**ESTES® LAUNCH SUPPLIES NEEDED (Sold Separately)**

- Porta-Pad® II Launch Pad
- Electron Beam® Launch Controller
- Recovery Wadding
- Starters (with engines)
- Plugs (with engines)
- Estes® Engines: B6-2, B4-4, B6-4, C5-3, C6-3

**PRECAUTIONS**



NAR SAFETY CODE



**NO DRY GRASS OR WEEDS**

**PRE-LAUNCH CHECK** For safety, never launch a damaged rocket. Check the rocket's body, nose cone and fins. Also, check the engine mount, recovery system and launch lug(s). Repair any damage before launching the rocket.

**FLYING YOUR ROCKET** Choose a large field (500 ft. [152 m] square) free of dry weeds and brown grass. The larger the launch area, the better your chance of recovering your rocket. Launch only with little or no wind and good visibility. Always follow the National Association of Rocketry (NAR) SAFETY CODE (enclosed).

**MISFIRES TAKE THE KEY OUT OF THE CONTROLLER. WAIT ONE MINUTE BEFORE GOING NEAR THE ROCKET.** Disconnect the micro-clips and remove the engine. Take the plug and starter out of the engine. A burned starter means the starter tip was not touching engine propellant. Install a new starter; be sure the tip is touching propellant inside the engine. Push the plug in place. Repeat steps under Countdown and Launch.

