



# Wolverine

0816

## PARTS LIST

- (A) 1 Balsa Nose Cone.....BNC-50BC
- (B) 1 Body Tube ..... BT-50H
- (C) 1 Engine Mount Tube .....BT-5BJ
- (D) 1 Paper Adapter .....RA-550
- (E) 1 Engine Hook .....EH-3
- (F) 1 Launch Lug .....LL-2A
- (G) 1 Die Cut Fin.....BF-0816
- (H) 1 Decal.....KD-0816
- (I) 1 Shock Cord.....SC-1
- (J) 1 Parachute ..... PK-10R
- (K) 1 Screw Eye.....SE-2
- (L) 1 Shock Cord Mount & Canopy .....SP-0816
- (M) 1 Dummy Engine.....EC-8
- (N) 1 Display Stand Card ..... 09014
- (O) 1 Instructions w/Marking Guide .....0816/2327-72

In addition to the materials above you will need scissors, a sharp hobby knife or single edge razor blade, sandpaper, masking tape, sanding sealer, and paint or dope. (Enamel based spray paint works best.)

## NOTE:

Read the instructions carefully before beginning work on your rocket. Then start construction, following each step in order, checking off each step as it is completed.

## WARRANTY

ESTES model rocket engines, kits, launch systems, and supplies are guaranteed against manufacturing defects. Any part or item found defective will be repaired or replaced without charge providing the defective part is returned postpaid to Estes Industries' Customer Service Department, Penrose, Colorado 81240. For fastest service, please send only the defective part.

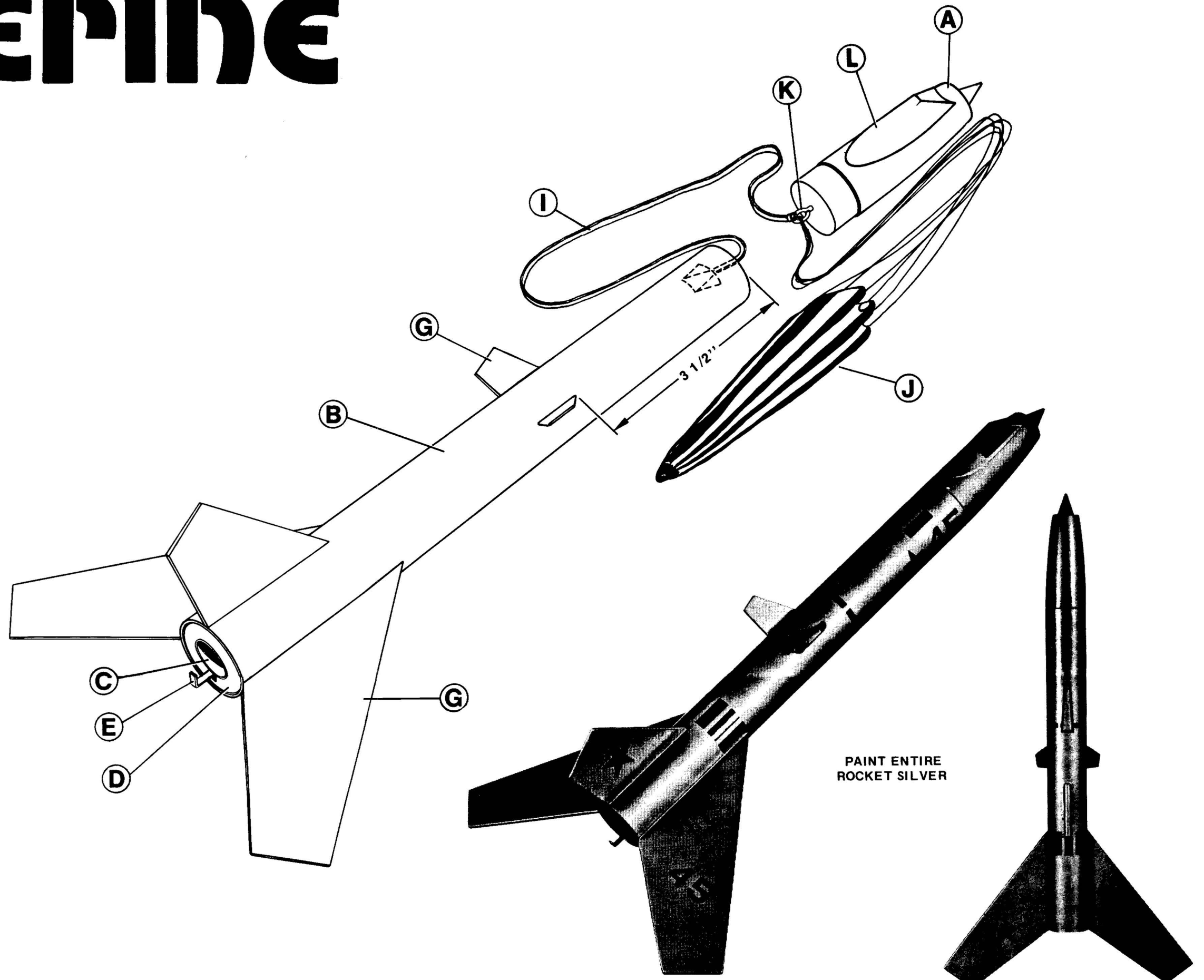

# Wolverine

0816

## PARTS LIST

- (A) 1 Balsa Nose Cone.....BNC-50BC
- (B) 1 Body Tube ..... BT-50H
- (C) 1 Engine Mount Tube .....BT-5BJ
- (D) 1 Paper Adapter .....RA-550
- (E) 1 Engine Hook .....EH-3
- (F) 1 Launch Lug .....LL-2A
- (G) 1 Die Cut Fin.....BF-0816
- (H) 1 Decal.....KD-0816
- (I) 1 Shock Cord.....SC-1
- (J) 1 Parachute ..... PK-10R
- (K) 1 Screw Eye.....SE-2
- (L) 1 Shock Cord Mount & Canopy .....SP-0816
- (M) 1 Dummy Engine.....EC-8
- (N) 1 Display Stand Card ..... 09014
- (O) 1 Instructions w/Marking Guide .....0816/2327-72

In addition to the materials above you will need scissors, a sharp hobby knife or single edge razor blade, sandpaper, masking tape, sanding sealer, and paint or dope. (Enamel based spray paint works best.)

## NOTE:

Read the instructions carefully before beginning work on your rocket. Then start construction, following each step in order, checking off each step as it is completed.

## WARRANTY

ESTES model rocket engines, kits, launch systems, and supplies are guaranteed against manufacturing defects. Any part or item found defective will be repaired or replaced without charge providing the defective part is returned postpaid to Estes Industries' Customer Service Department, Penrose, Colorado 81240. For fastest service, please send only the defective part.

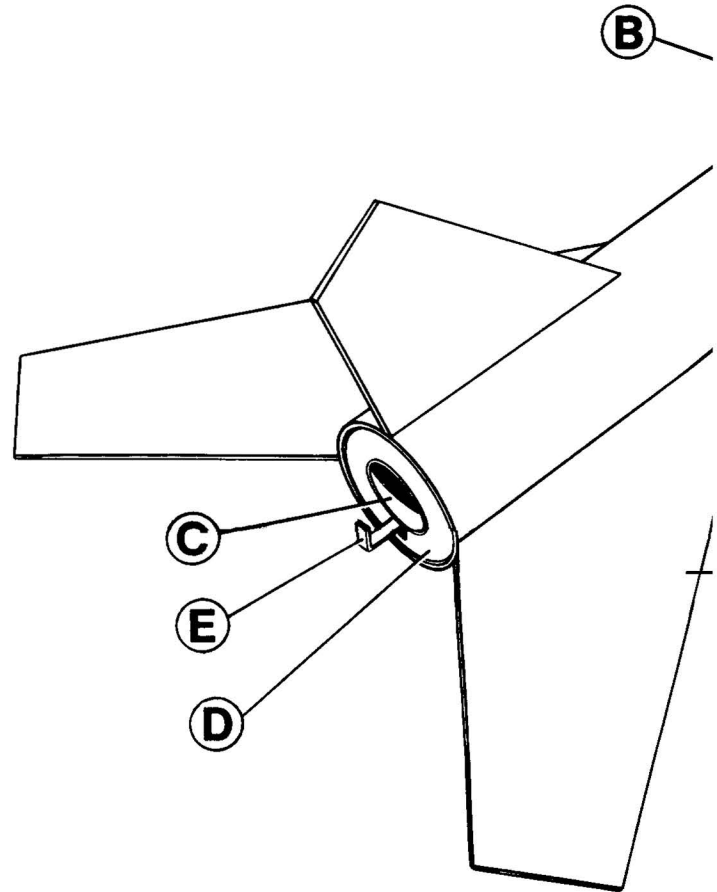

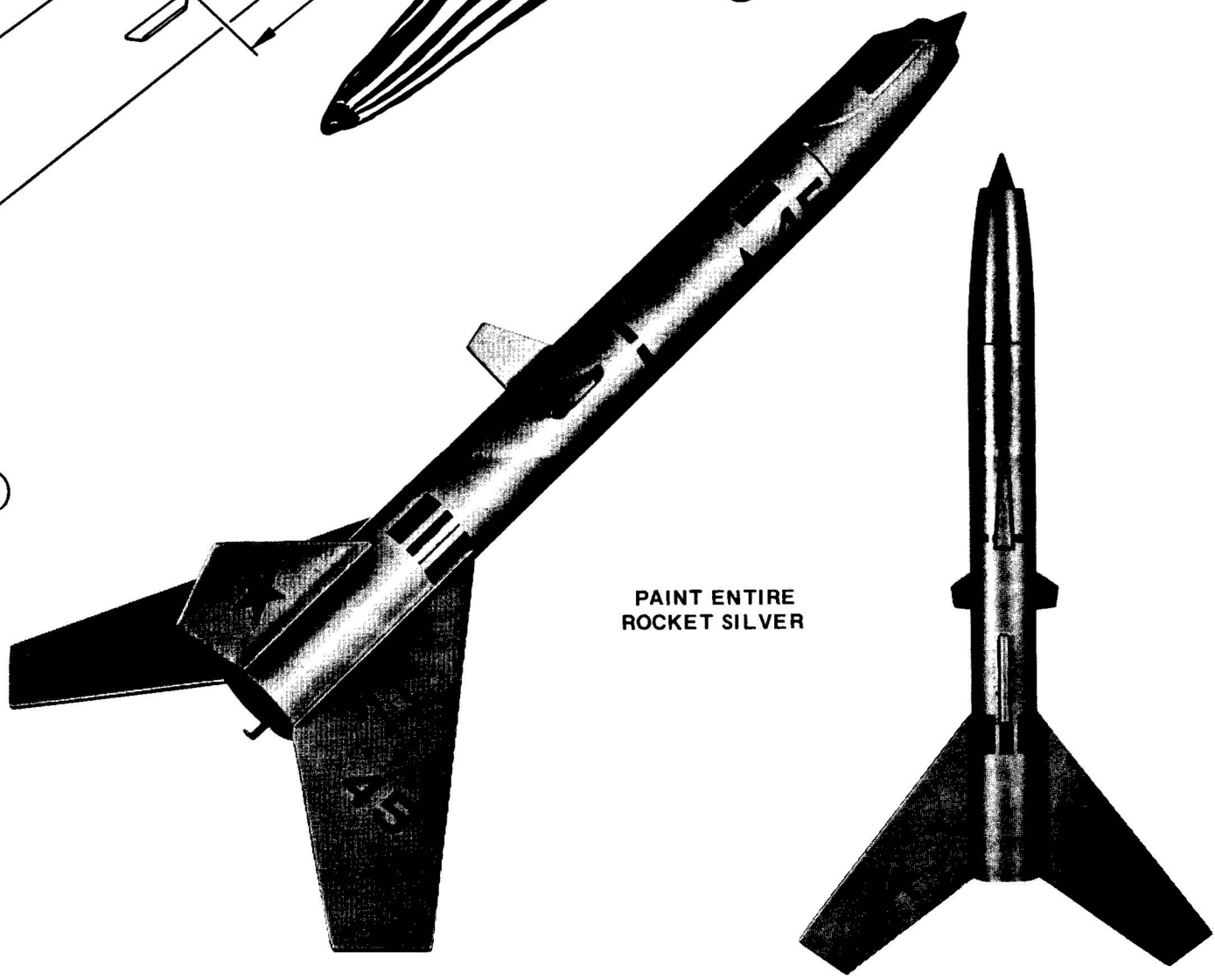
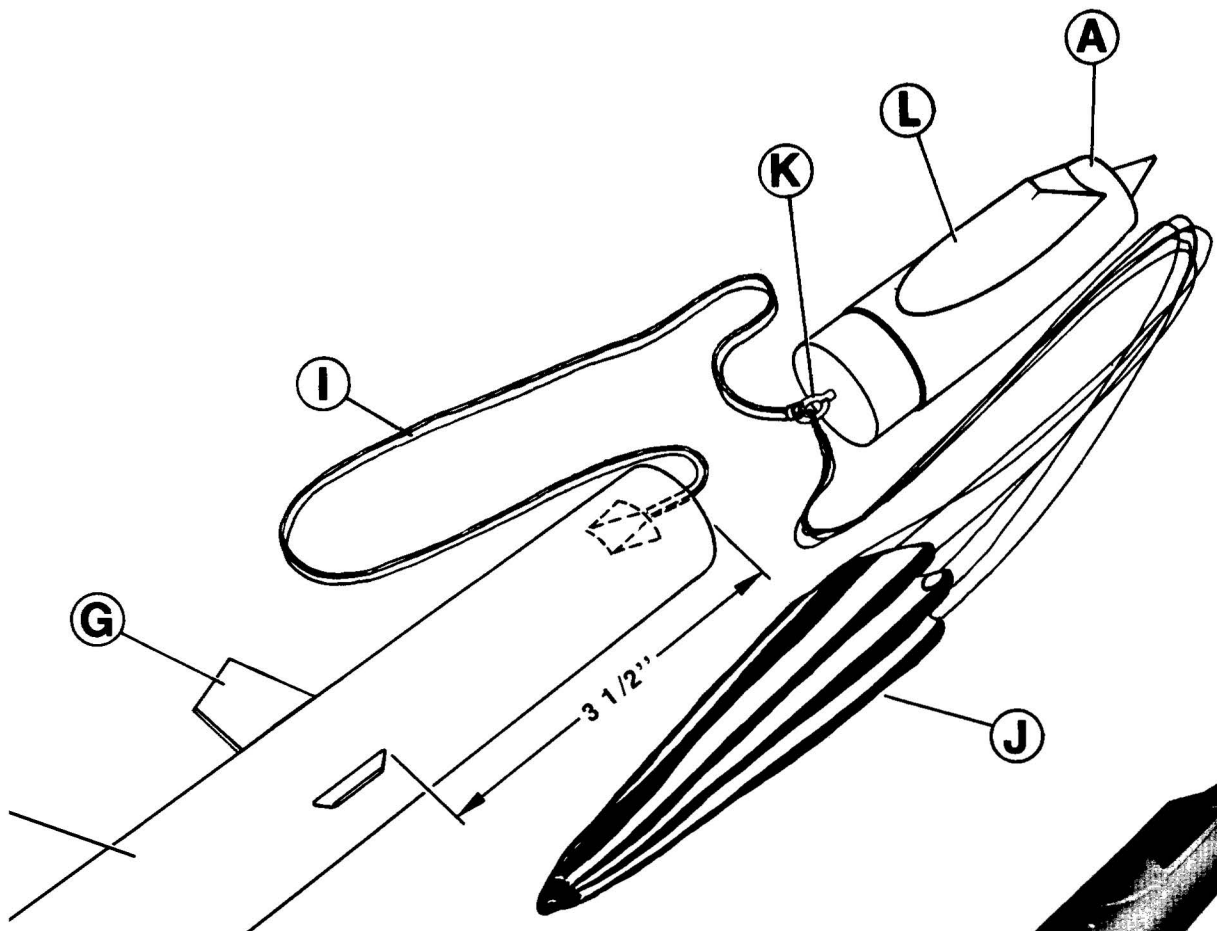

PAINT ENTIRE  
ROCKET SILVER

# ASSEMBLY INSTRUCTIONS

**1** Cut a 1/8" wide slit 1-1/2" from one end of the engine mount tube. Insert the engine hook into the slit. Wrap one layer of tape around the middle of the tube over the hook as shown. Apply glue over the slit where the hook enters the tube.

**2** Glue the rings on in the positions shown, with the notched ring over the engine hook. Let this assembly dry completely.

**3** Locate the centers of the shroud lines and knot the lines together at this point. Make sure the tape discs hold the shroud lines securely on the parachute.

**4** Smear glue around the inside of the body tube about 3/4" from one end. Immediately slide the engine mount unit into place so the end of the engine mount tube is even with the rear of the body tube. Do not pause during this operation or the glue may stick with the mount in the wrong place. Apply glue to joint between end of body tube and paper adapter ring.

**5** Cut out the body tube marking guide from instructions near Misfire Procedure. Wrap it around the rear of the body tube so the ends of the guide are in line with engine hook. Mark the tube at each arrow point. Using a door frame or drawer edge, draw lines the length of the body tube on the marks. Refer to overall layout drawing for positioning of forward fins.

**6** Fine sand the balsa sheet, then carefully remove the die cut fins from the sheet. Free the edges with a sharp hobby knife. Sand all fins to an airfoil cross-section.

**7** Rub a line of glue into the root edge of each fin and allow to dry. Position and glue the fins on the alignment lines in the positions shown. Align each fin straight away from the body tube. Apply a glue fillet to both sides of each fin joint after the glue is completely dry.

**8** Glue the launch lug to the body next to the alignment line, 2-1/2" from the rear of the body tube.

**9** Cut out the shock cord mount. Pre-fold it on the dotted lines. Apply glue to section 1 and lay the shock cord end onto the glue. Fold this first section over. Spread glue over the back of the first section and the exposed part of section 2. Lay the shock cord as shown and fold over again. Clamp the unit together with your fingers until the glue sets.

**10** Apply glue to the inside of the body tube at the front over an area about 1" to 1-3/4" from the end. The glued area should be the same size as the shock cord mount. Press the mount into the glue, and hold it until the glue sets.

**11** Cut out the canopy on the heavy outlines. Fold inward on the dotted lines. Roll the sides down around a pencil. Glue the front to the sides. Glue the canopy to the nose cone.

**12** Insert the screw eye into the base of the nose cone. Remove and squirt a small amount of glue into the hole. Re-insert the screw eye.

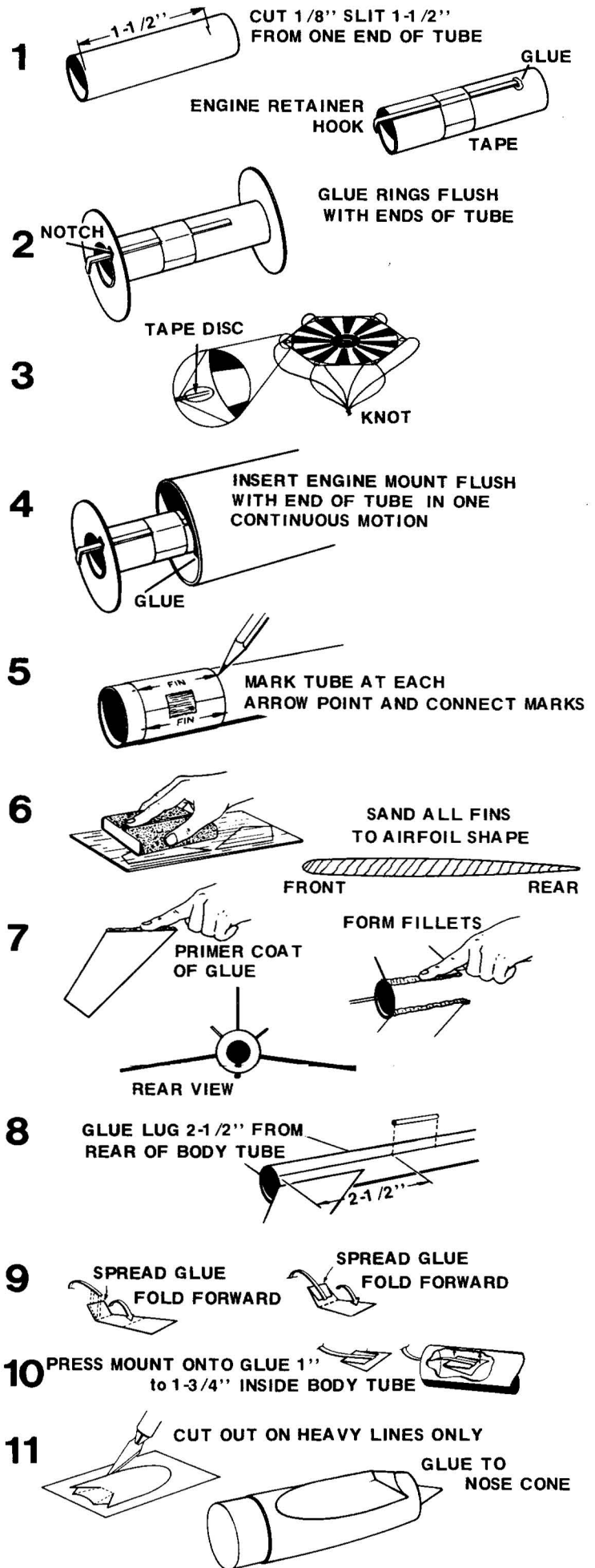

13 Tie the free end of the shock cord and shroud lines from the parachute to the screw eye.

14 Apply two or more coats of sanding sealer to all balsa surfaces. Sand lightly with extra fine sandpaper between coats. Repeat until all pores are filled and the surfaces smooth. Give the rocket two light base coats of silver. Follow with a heavier coat of silver to give "wet look". Apply decals as shown in the decor photo.

15 Assemble the display stand according to the instructions on the back of the card.

## COUNTDOWN CHECKLIST

14. Pack four squares of crumpled recovery wadding loosely into body tube.

13. Fold the parachute into a triangular shape. Roll 'chute tightly as shown and wrap shroud lines around it. If 'chute is too large, unroll and repack until it slides easily into the rocket. A very tight fit may prevent parachute from ejecting properly.

Pack shock cord neatly into rocket. NOTE: DO NOT pack parachute until you are actually ready to launch. For maximum parachute reliability, lightly dust the 'chute with ordinary talcum powder before each flight, especially in colder weather.

12. Slide nose cone into place. Nose cone should separate easily from rocket body tube, but not be extremely loose. If fit is too tight, sand inside of body tube end and shoulder of nose cone with fine sandpaper.

If nose cone is too loose, add a wrapping of transparent tape or masking tape to the shoulder of the nose cone.

11. Select an engine and install an igniter as directed in the engine instructions. Use 1/2A3-2T engine for first flight. Engines recommended for use with this rocket are 1/2A3-2T and A3-4T.

10. Insert engine into rocket. Engine hook must latch securely over the end of the engine.

9. Disarm the launch panel – remove safety key.

8. Place rocket on launch pad making sure rocket slides freely on launch rod. Clean the micro-clips and attach them to the igniter.

7. Clear the launch area, alert recovery crew and trackers. Check for low flying aircraft and unauthorized persons in the recovery area.

6. Arm the launch panel – insert safety key.

5    4    3    2    1    LAUNCH!!

## MISFIRE PROCEDURE

Occasionally the igniter will heat and burn in two without igniting the engine. This is almost always caused by a failure to install it correctly. Disarm the launch panel, remove the model, clean the igniter residue from the nozzle, and install a new igniter. Follow the launching procedure again.

12



13

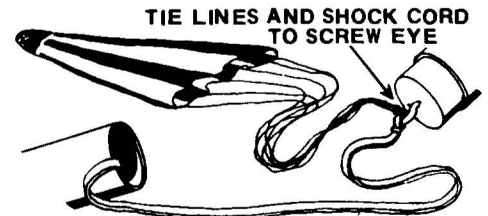

14

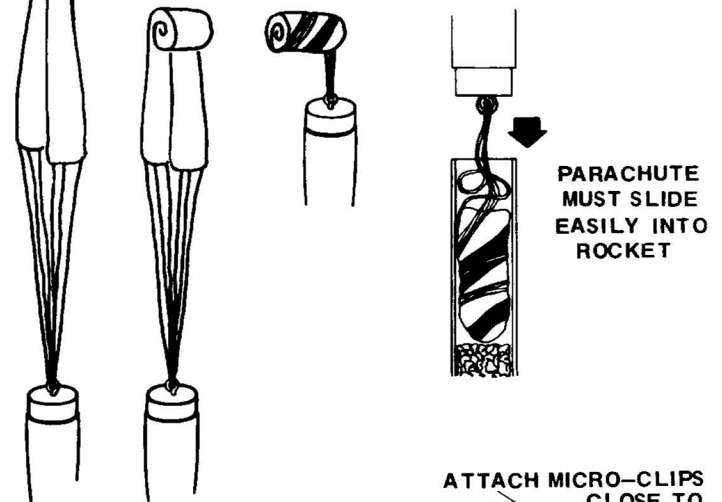
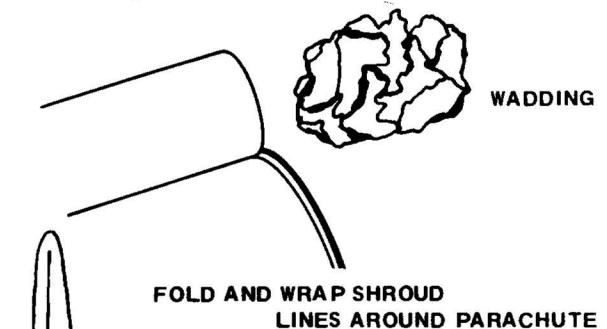
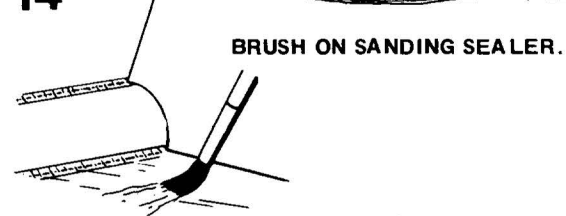

BF-0816

82270

SONIA

VERTICAL FIN

GARAGE

THE L.S. STARRETT CO.  
ATHOL, MASS., U.S.A.

No. C303SR

TEMPERED

7

11

8

10

9

8

10

8

11

7

12

6

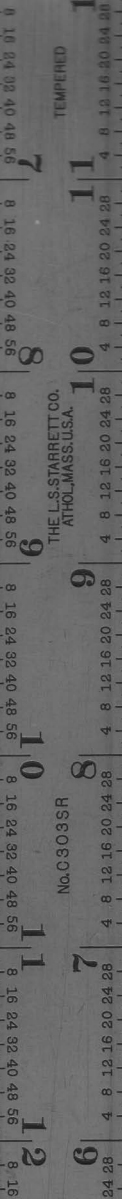



**SP-0816**

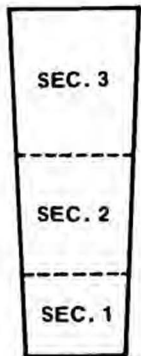

**SHOCK CORD MOUNT**

**82252**





45

45



45

45

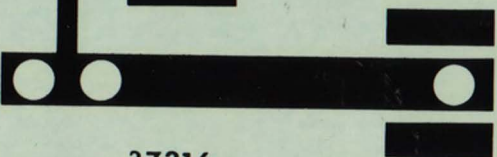

WOLVERINE

37316

KD-0816 ESTES INDUSTRIES

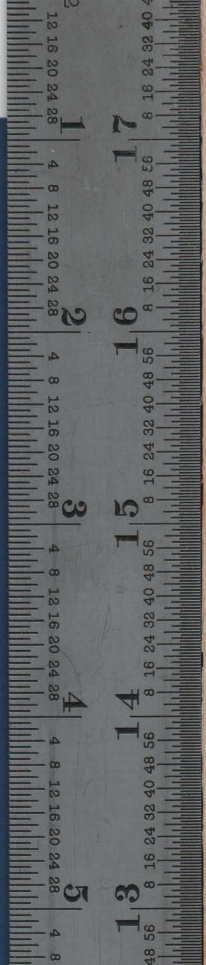



**45**

**45**



**45**



**45**

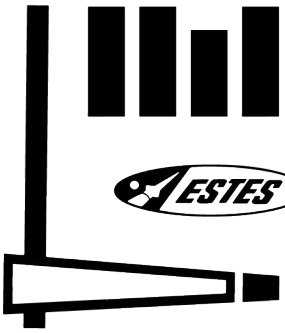
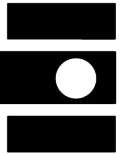
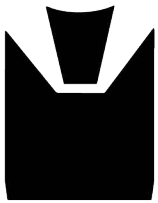

**WOLVERINE**



# THE BADDER WOLVERINE



- RUSSIAN HYPERSONIC INTERCEPTOR
- FUTURISTIC NEAR-SPACE DESIGN
- TWO COLOR RUSSIAN DECALS
- SCRAM-JET APPEARANCE

## SKILL LEVEL 7

1-Beginner 2-Intermediate 3-Chiefman 4-Advanced 5-Expert

## SPECIFICATIONS

Length 11.25" (28.9 cm.)

Weight 0.875 oz. (24.8 g.)

Body Dia. 0.875" (24.8 mm.)

Parachute Recovery

## RECOMMEND ENGINE(S)

1/2A3-2T A3-4T

Use 1/2A3-2T for first flights.

Engines and launcher not included.