





A DAMON COMPANY

ESTES INDUSTRIES
1295 H Street
Penrose, CO 81240 USA

NASA X-15™

FLYING MODEL ROCKET #0889

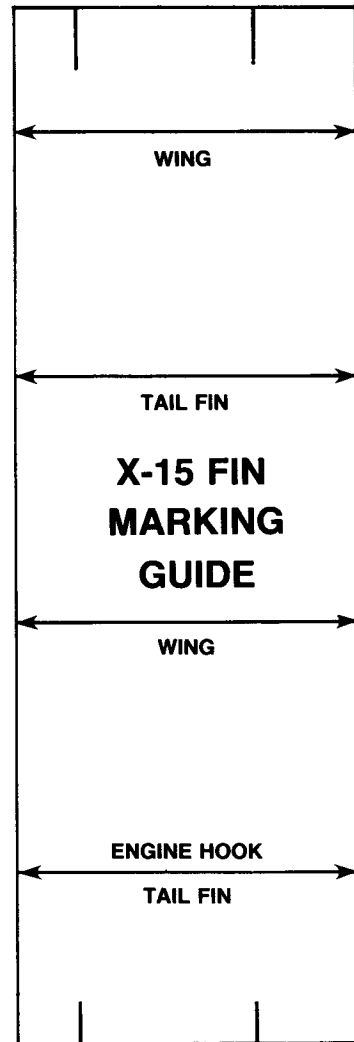

PARTS AND SUPPLIES

Locate the parts shown below and lay them out on the table in front of you. In addition to the parts included in the kit you will also need:

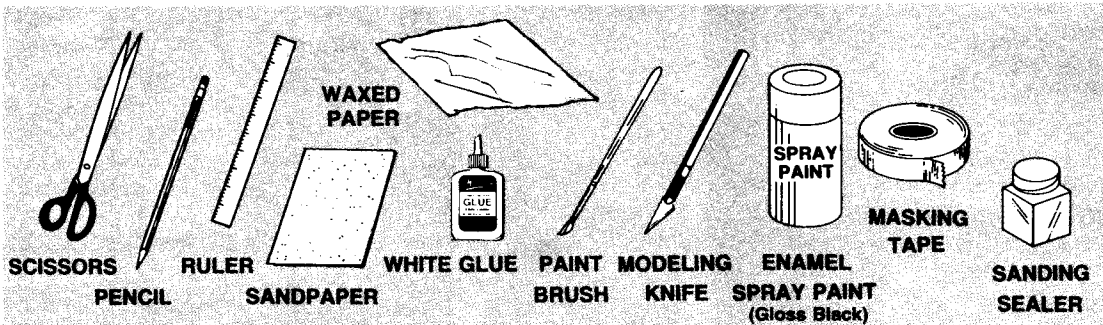

ASSEMBLY TIP

Read all instructions before beginning work on your model. Make sure you have all parts and supplies. Test fit all parts together before applying any glue. If any parts don't fit properly, sand as required for precision assembly.

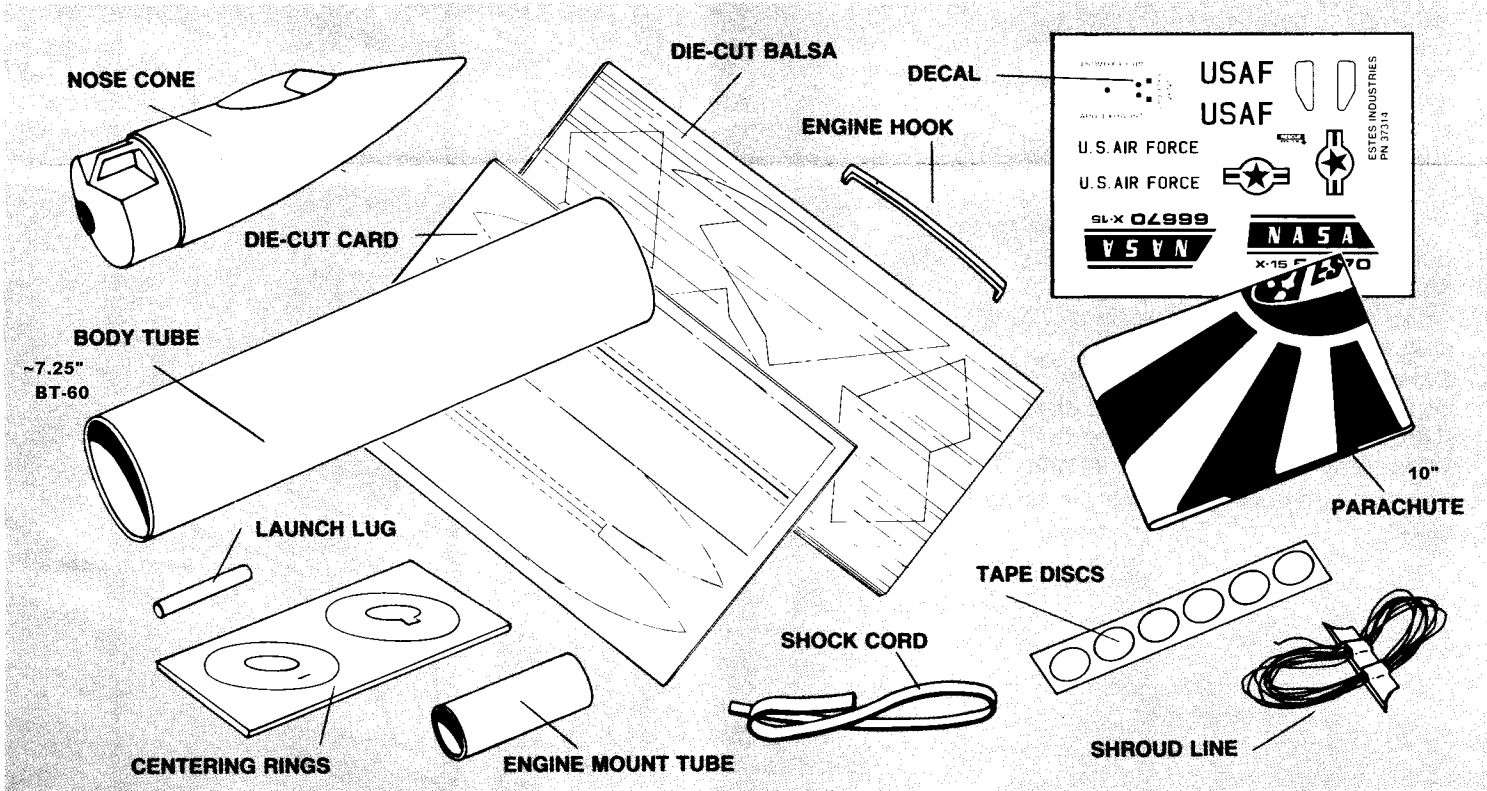

ROCKET ASSEMBLY

- 1**
- A. Mark engine mount tube at 1 inch and $1\frac{3}{8}$ inches from one end of tube.
- B. Cut $\frac{1}{8}$ inch long slit at $1\frac{3}{8}$ inch mark.
- C. Insert one end of engine hook into slit.
- D. Wrap masking tape twice around assembly at 1 inch mark.
- E. Slide adapter ring with slit in it onto front of tube even with end of tube. Glue both sides of ring tube/joint.
- F. Slide slotted adapter ring onto rear of tube even with end of tube. Glue both sides of ring/tube joint.

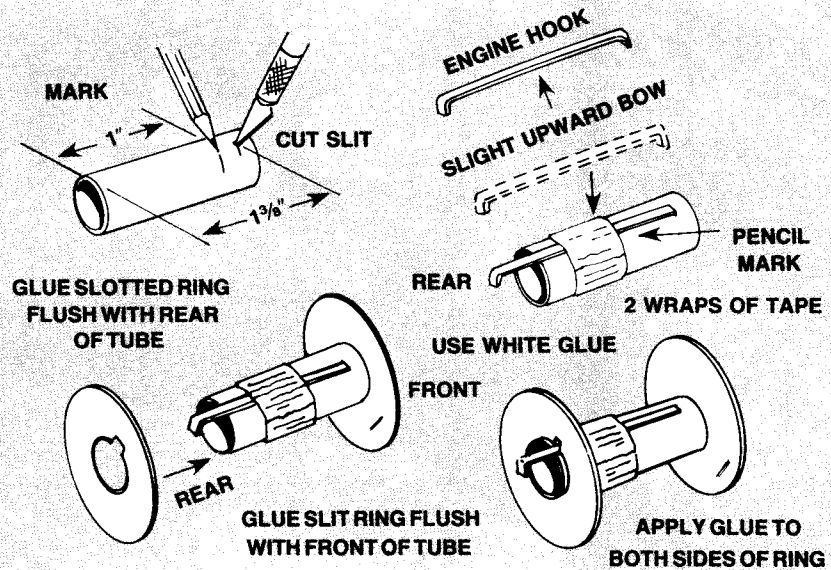

- 2**
- A. Widen slit in ring of engine mount.
- B. Pass shock cord through slit in ring.
- C. Tie a double knot in end of shock cord.
- D. Pull shock cord tight against ring. Apply glue to knot to secure it to adapter ring.

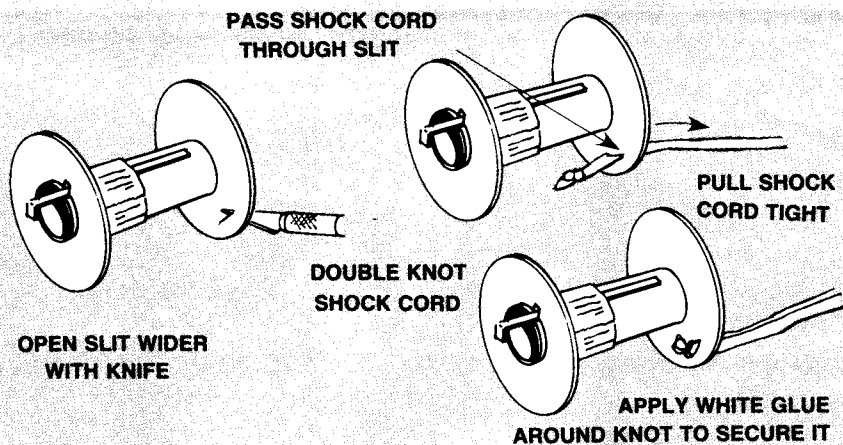

- 3**
- A. Fine sand balsa die-cut sheet. Carefully remove fins by freeing edges with sharp knife.
- B. Stack alike fins together. Sand all edges smooth.

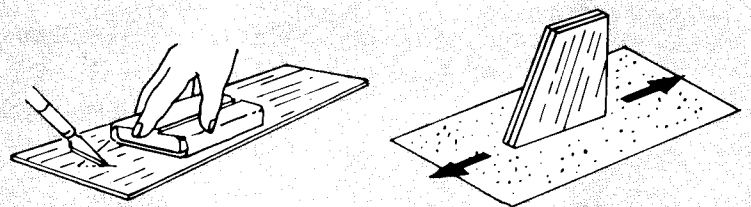

- 4**
- A. Sort and identify the parts.
- B. Assemble wing parts over a piece of waxed paper, on a flat surface. Apply glue to edge of part to be joined.
- C. Press parts together. Use a ruler to make sure bottom edges of parts are straight. If not, adjust parts to make edge straight. Wipe away excess glue and let dry.
- D. Assemble other wing assembly in same manner.

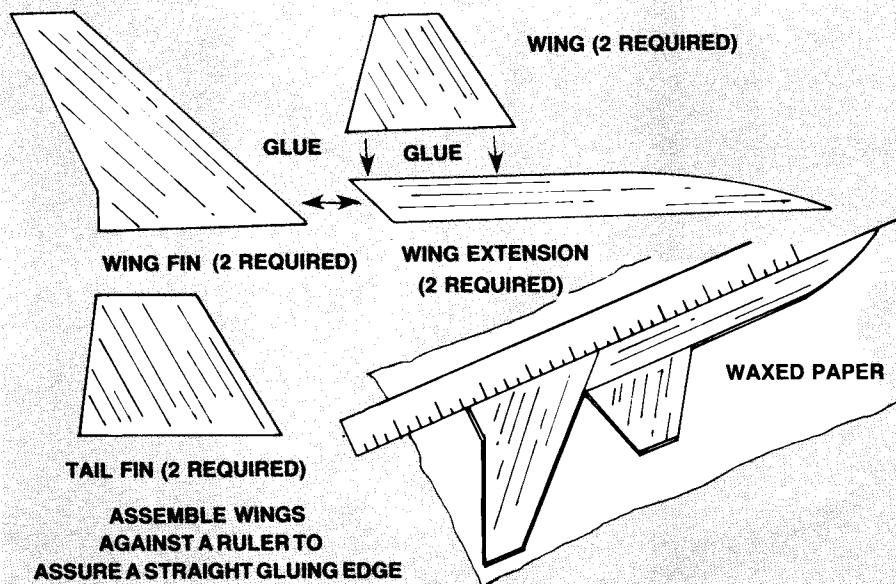

5

- A. Smear glue inside body tube 1/2 inch from one end.
- B. Pass shock cord through body tube and push engine mount into tube until end of engine hook is even with end of tube.
- C. Apply glue to inside of ring/tube joint.

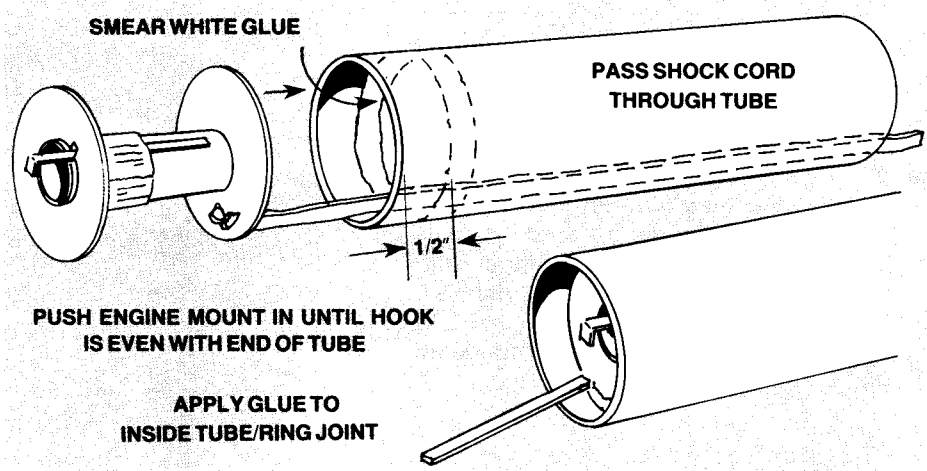

6

- A. Cut out tube marking guide from front of instructions.
- B. Wrap guide around tube and tape. Mark tube at arrows.
- C. Draw straight lines connecting each pair of marks. Extend lines length of tube.

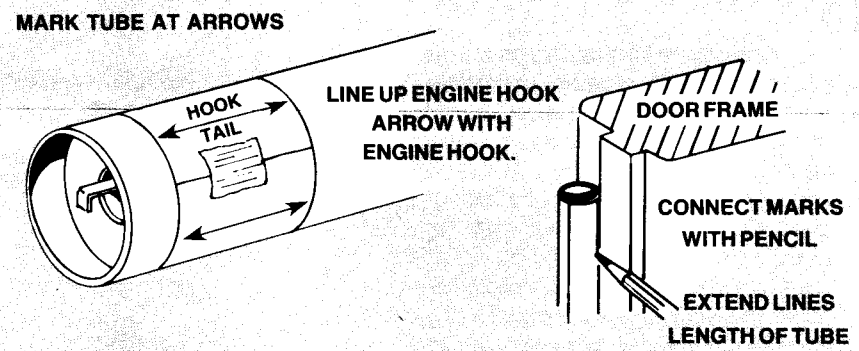

7

- A. Position and glue wings on opposing alignment lines as shown one at a time. Let each dry several minutes before applying the next one.
- B. Adjust wings to project straight out from tube.
- C. Do not set rocket on wings until glue is DRY.
- D. Allow wings to dry before proceeding to next step.

WINGS MUST BE ATTACHED CORRECTLY FOR STABLE FLIGHT!

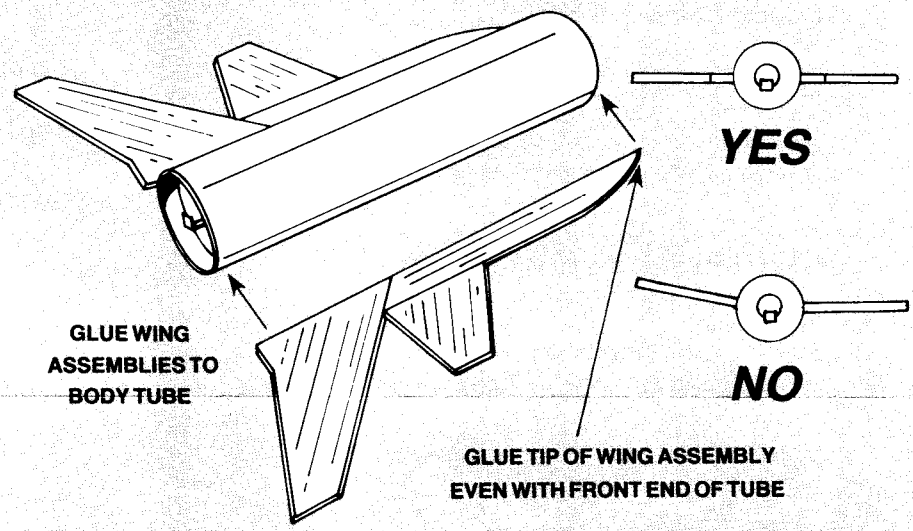

8

- A. Apply a glue reinforcement to each side of all wing/body tube joints.
- B. Support rocket horizontally until glue dries.

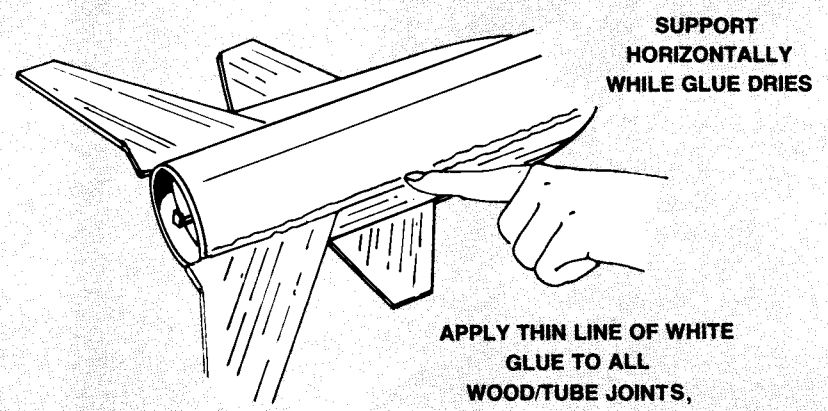

9

- A. Remove the wing shrouds, two left and two right, from the die-cut card.
- B. Lay wing shroud on flat surface with shiny side down. Carefully fold glue tab over onto shroud.
- C. Make two rights and two left shrouds in same manner.

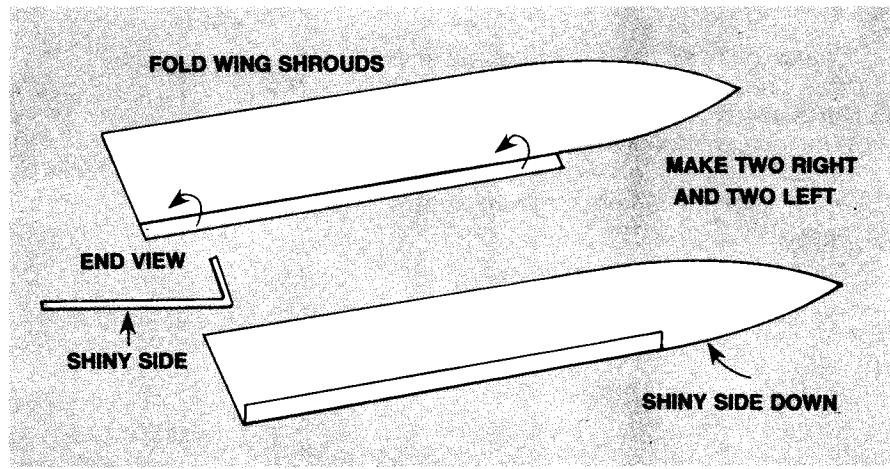

10

- A. Apply glue to glue tab on shroud and position on top of wing assembly. The rear of shroud should be even with end of tube and even with edge of wing assembly.
- B. After glue has set apply glue to edges of shroud and bend shroud over against body tube and hold until glue sets. Make sure shroud is glued securely to body tube and wing assembly with no gaps.
- C. Repeat assembly procedures for remaining shrouds. Apply a bead of glue to joints of shroud to help fill seams of joint. Smooth glue with finger.

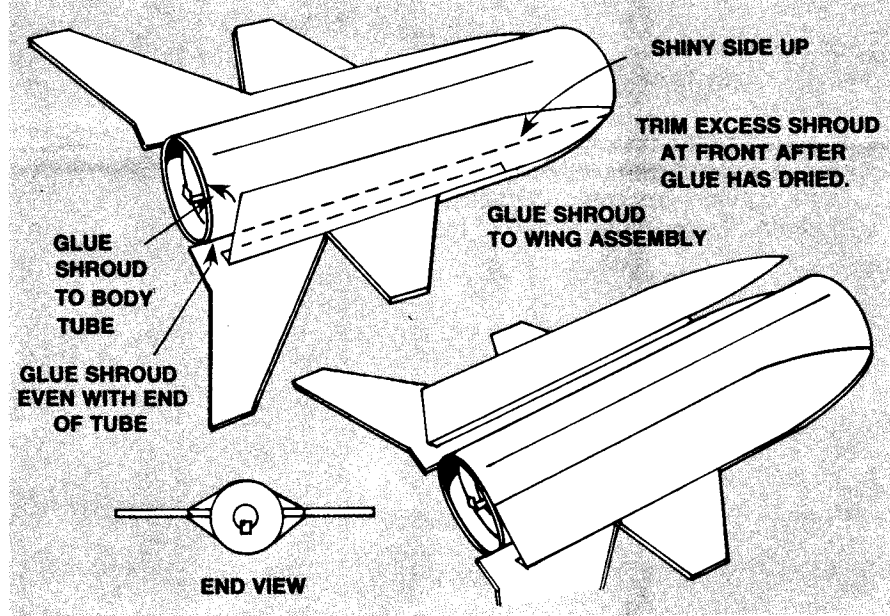

11

- A. Glue tail fins on top and bottom alignment lines. Make sure rear of each tail is even with end of tube.
- B. Adjust tail to project straight out from tube and perpendicular to wings.

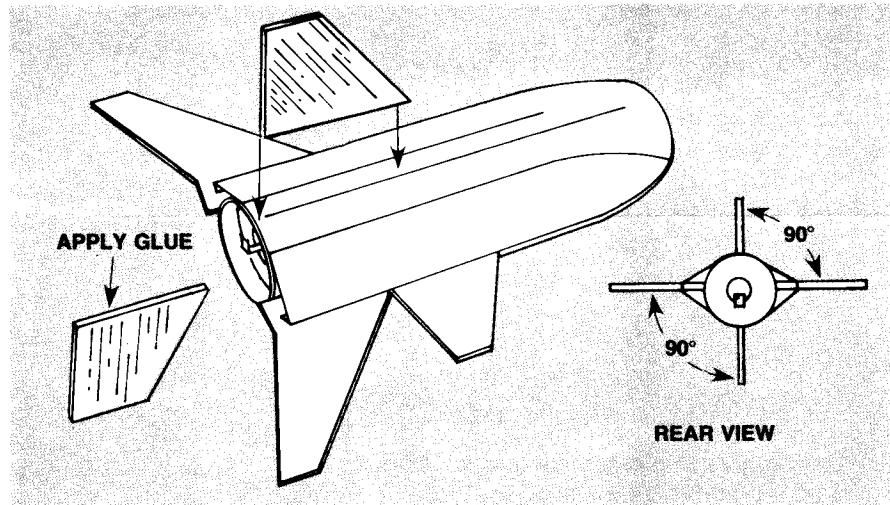

12

Glue launch lug straight on shroud/body tube joint 3 inches from rear of tube.

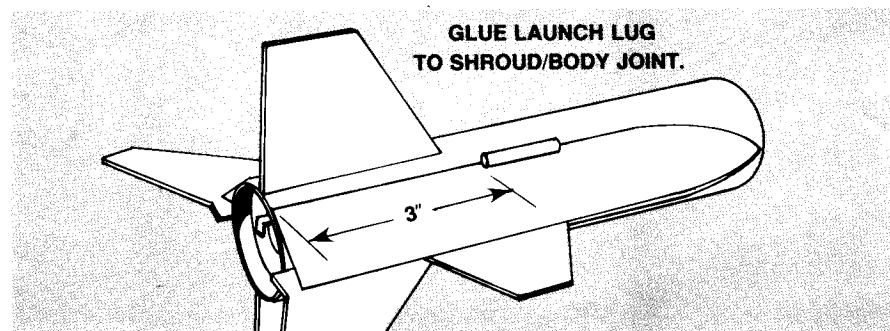

13

- A. Apply glue reinforcements to all wing/body tube joints.
- B. Support rocket horizontally until glue dries.

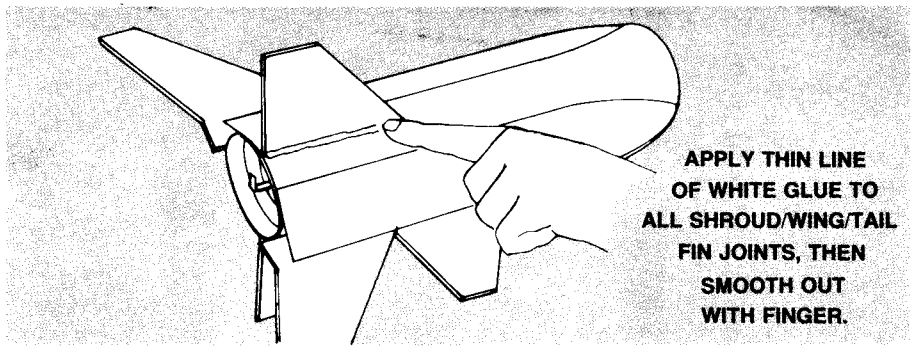

14

- A. Trim excess plastic from around sides of nose cone with a sharp knife. Also remove any excess plastic from inside molded eyelet.
- B. Wipe nose cone with damp cloth to remove oil and dirt.

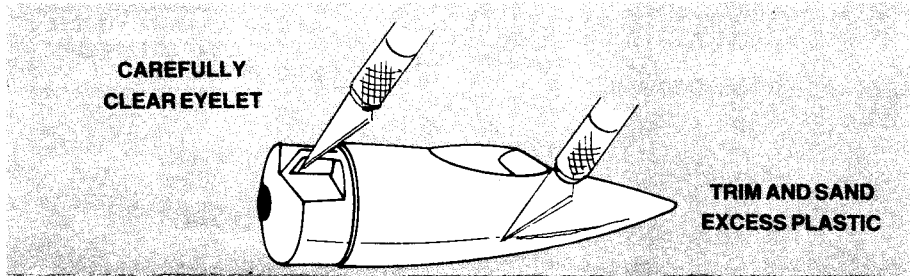

15

- A. Cut out parachute on edge lines.
- B. Cut three 22 inch lengths of shroud line.
- C. Form small loops with shroud line ends and press onto sticky side of tape discs.
- D. Attach tape discs with line ends to top of parachute as shown.
- E. Firmly press tape discs into place until both tape discs and parachute material are molded around shroud line loops.
- F. Pass shroud line loops through loop on nose cone. Pass parachute through loop ends and pull lines against the nose cone.
- G. Tie free end of shock cord to nose cone eyelet.
- H. Fold parachute, then insert parachute and nose cone into rocket.

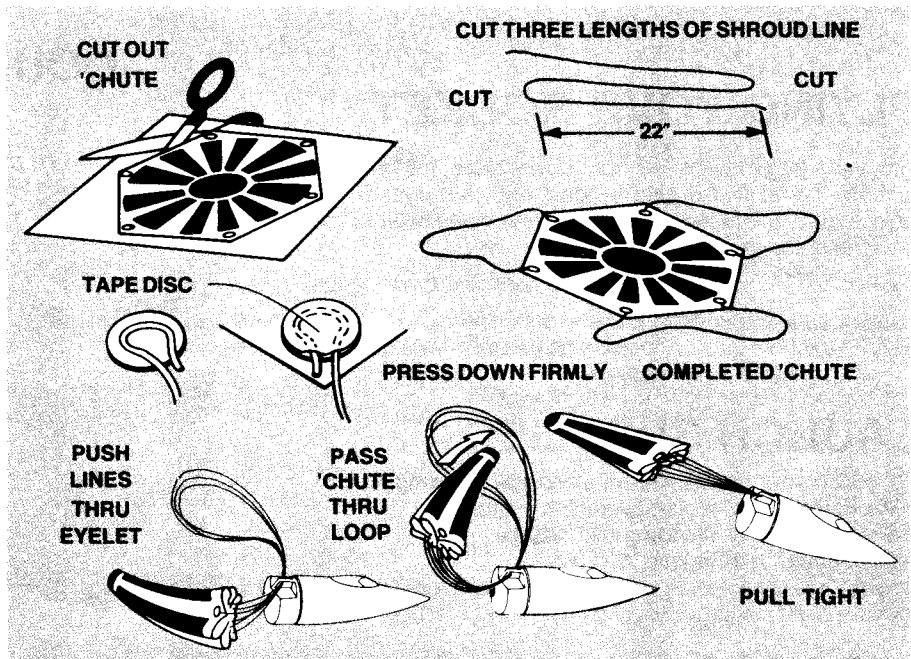

FINISHING YOUR ROCKET

Apply sanding sealer to all paper and wood parts. When sealer is dry, lightly sand parts. Repeat sanding and sealing until parts are smooth. Spray paint entire model gloss black. Follow instructions on spray can for best results. Allow paint to dry overnight before applying decals.

Refer to illustration and photo on panel for decal placement. To apply decals, cut out each decal, trim away clear as close to detail as possible. Dip in lukewarm water for 20 seconds, hold until it uncurls, slip decal off backing sheet onto model. and blot excess water.

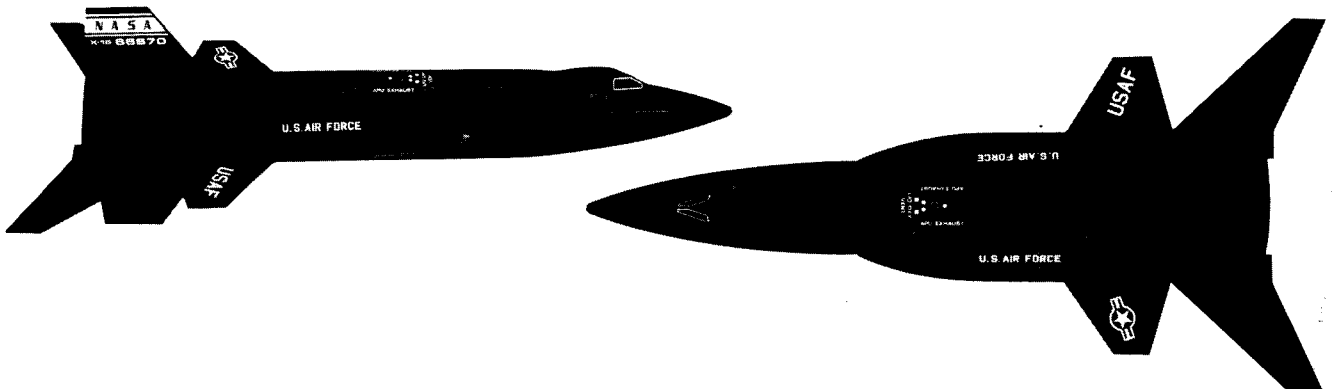

ROCKET PREFLIGHT

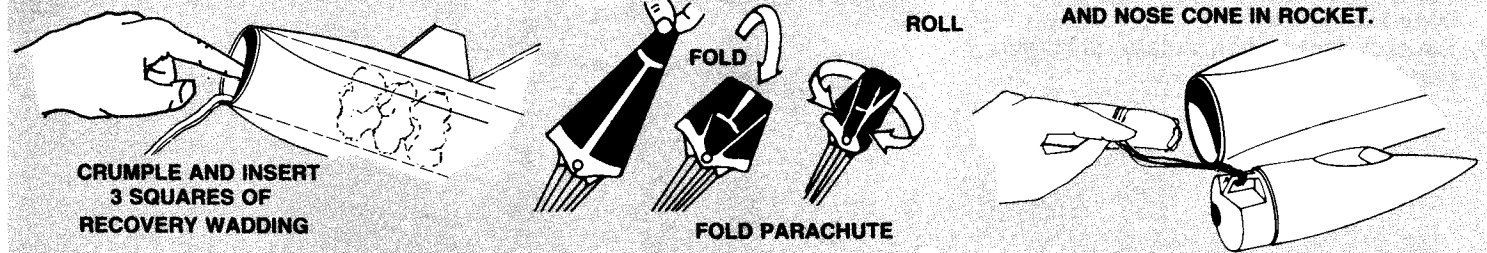

PREPARE ENGINE

SEPARATE THE IGNITERS

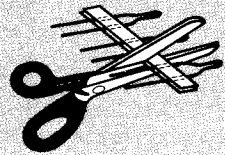

ENGINE

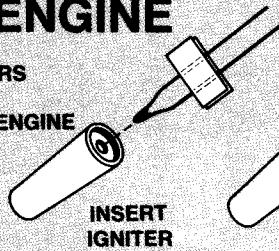

IGNITER TIP MUST TOUCH PROPELLANT DEEP INSIDE NOZZLE OPENING

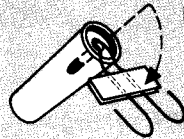

APPLY AND FIRMLY PRESS TAPE DISC OR MASKING TAPE IN PLACE

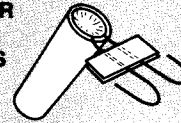

INSTALL ENGINE IN ROCKET

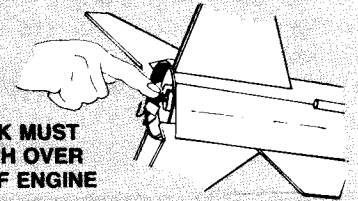

FLYING YOUR ROCKET

Choose a large field away from power lines, tall trees, and low flying aircraft. Try to find a field at least 250 feet square. The larger the launch area, the better your chance of recovering your rocket. Football fields and playgrounds are great.

Launch area must be free of dry weeds and brown grass.

Launch only during calm weather with little or no wind and good visibility. Parachute may be dusted with talcum powder to avoid sticking.

LAUNCH SUPPLIES

To launch your rocket you will need the following items:

- An Estes model rocket launching system
- Estes Recovery Wadding (No. 2274)
- Recommended Engine: A10-3T

Use A10-3T engine for your first flight to become familiar with your rocket's flight pattern.

MISFIRES

Failure of the rocket engine to function properly is nearly always caused by a failure to install the igniter correctly. This failure permits the igniter to heat and burn into two pieces without igniting the engine.

FOR YOUR SAFETY AND ENJOYMENT

Always follow the NAR-HIA* MODEL ROCKETRY SAFETY CODE while participating in any model rocketry activities.

*National Association of Rocketry-The Hobby Industry of America

COUNTDOWN AND LAUNCH

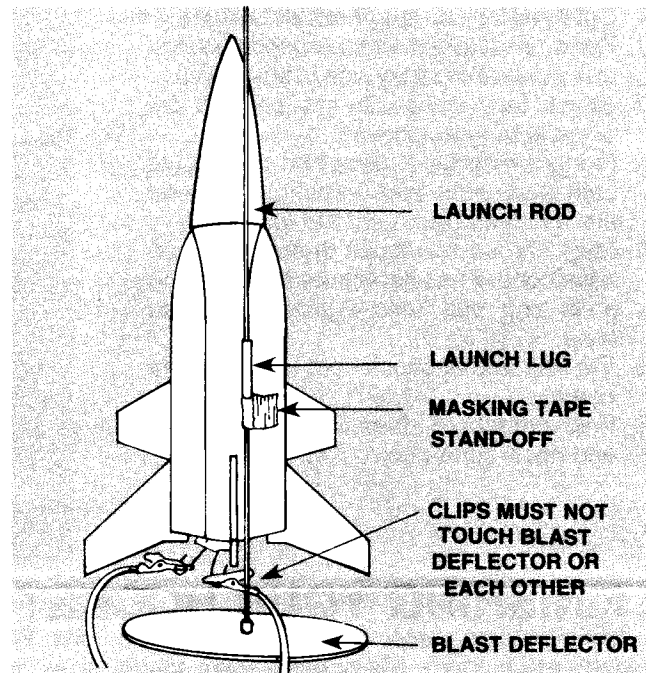

- ⑩ REMOVE SAFETY KEY to disarm the launch controller.
- ⑨ Remove safety cap and slide launch lug over launch rod to place rocket on launch pad. Make sure the rocket slides freely on the launch rod.
- ⑧ Attach micro-clips to the igniter wires. Arrange the clips so they do not touch each other or the metal blast deflector.
- ⑦ Move back from your rocket as far as launch wire will permit, (at least 15 feet).
- ⑥ INSERT SAFETY KEY to arm the launch controller. Give audible countdown 5...4...3...2...1

LAUNCH!!! PUSH AND HOLD LAUNCH BUTTON UNTIL ENGINE IGNITES

Remove safety key—Replace cap on rod.

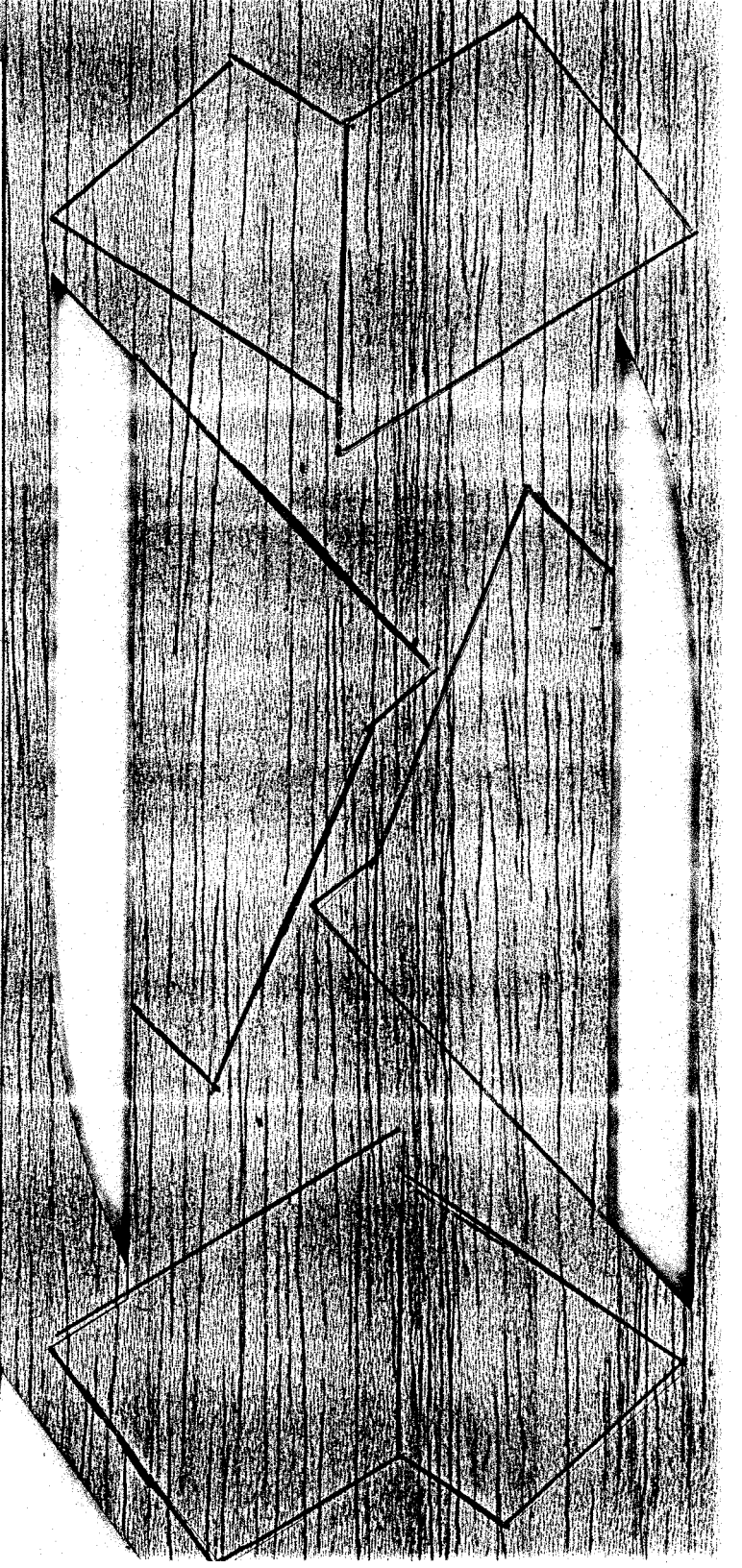

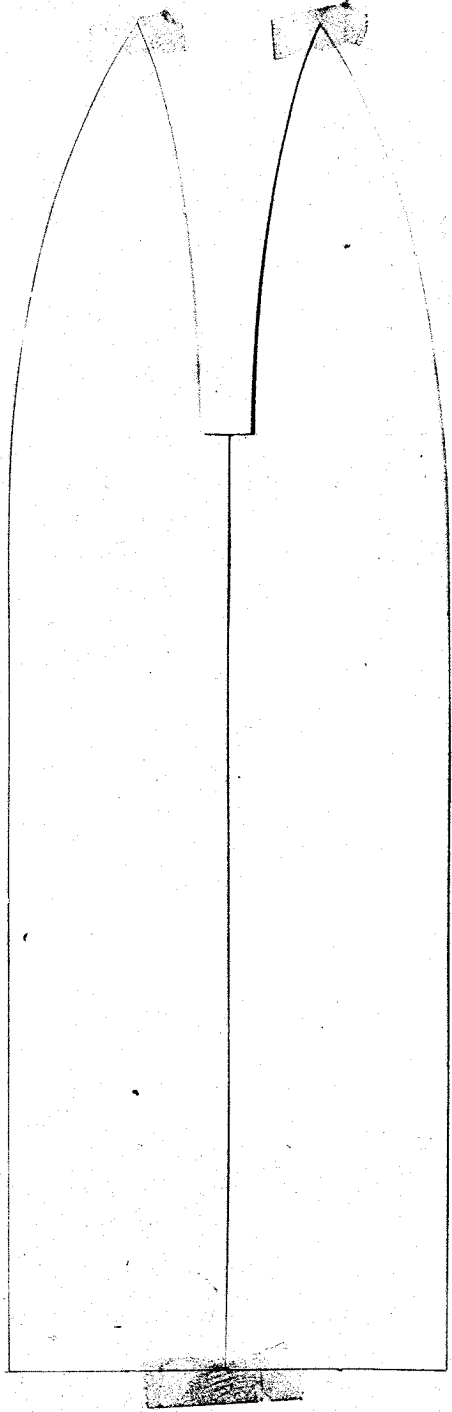
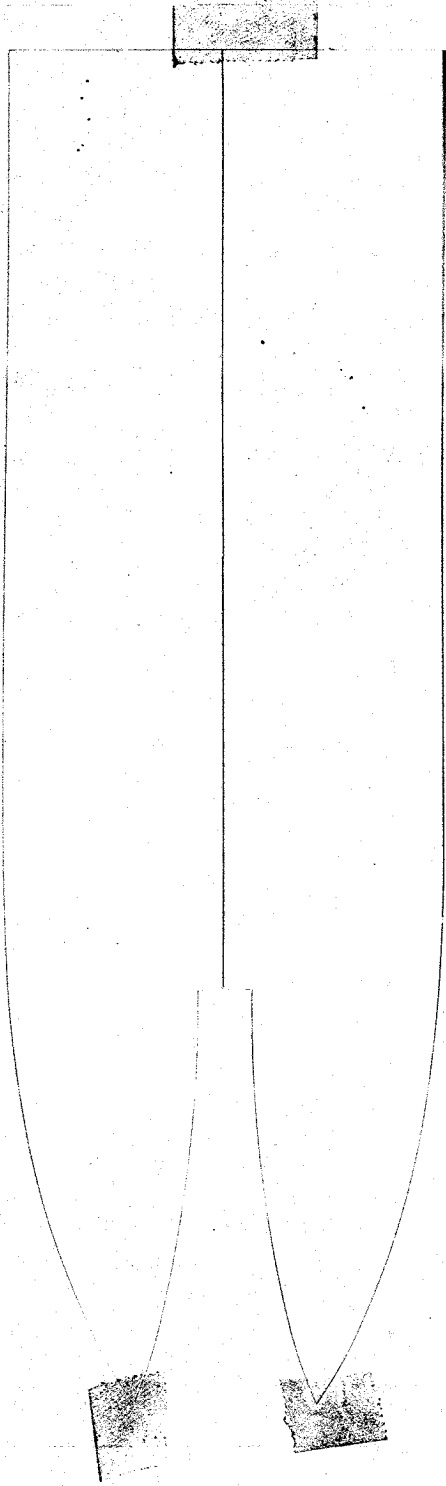

APU EXHAUST



APU EXHAUST

U.S. AIR FORCE

U.S. AIR FORCE

USAF

USAF



51-X 04999

NASA

NASA

X-15 66670

ESTES INDUSTRIES
PN 37314

APU EXHAUST



APU EXHAUST

USAF
USAF



U.S. AIR FORCE

U.S. AIR FORCE



**ESTES INDUSTRIES
PN 37314**

07999

X-15

NASA

X-15

66670

NASA