



shown. Pass the shroud line loop ends through the nose cone screw eye. Pass the parachute through the loop ends and pull the lines tight against the screw eye. "Set" the knot with a drop of glue. Tie the free end of the shock cord to the screw eye with a double knot.

**11** Using extra-fine sandpaper, sand all balsa surfaces until smooth. Coat these surfaces with sanding sealer and sand again with extra-fine grit sandpaper. The smoother the surface of the rocket, the better it will fly. Let sealer dry, then give the rocket a clean base coat of gloss white paint or dope and let dry overnight. For suggested paint scheme, paint nose cone black and fins red. Add decorative tape to customize, if desired. For greater visibility, give it a bright coat of fluorescent orange paint.

**LAUNCHING COMPONENTS**

To launch your rocket you will need the following items:

- An Estes model rocket launching system.
- Flameproof recovery wadding (Estes Cat. No. 2274)
- Estes 1/2A6-2, A8-3, B4-4, B6-6, or C6-7 model rocket engines. Use a 1/2A6-2 engine for the first flight.

Be sure to follow the HIAA-NAR\* Model Rocketry Safety Code when carrying out your model rocketry activities.

\* HIAA - Hobby Industry Association of America  
NAR - National Association of Rocketry

**COUNTDOWN CHECKLIST**

**T-14** Pack four squares of loosely crumpled recovery wadding into the body tube.

**T-13**

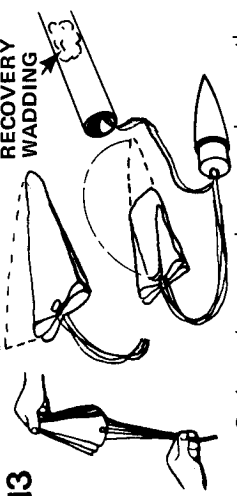

Gather the parachute as shown, then fold into a triangular shape. Fold again and insert into rocket body.

**NOTE:** DO NOT pack parachute until you are actually ready to launch. For maximum parachute reliability, lightly dust the chute with ordinary talcum powder before each flight, especially in cold weather.

**T-12** Pack parachute, shroud lines, and shock cord neatly into the body tube. Slide nose cone into place. Nose cone should separate easily from rocket body tube. Refer to step 1 for fitting procedure.

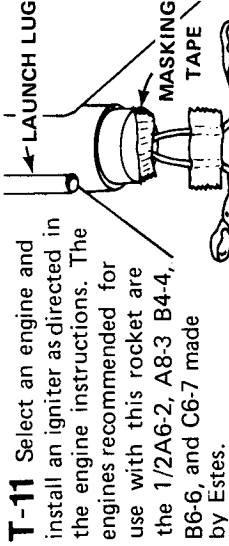

**T-11** Select an engine and install an igniter as directed in the engine instructions. The engines recommended for use with this rocket are the 1/2A6-2, A8-3 B4-4, B6-6, and C6-7 made by Estes.

Use a 1/2A6-2 engine for your first flight.

**T-10** Wrap the rear of the engine with enough masking tape so that it makes a tight fit in the body tube. This fit must be tight to obtain proper parachute deployment. Insert the engine into the rocket so the rear of the engine projects 1/4" from the rear of the body tube.

**T-9** Disarm the launch panel -- REMOVE SAFETY KEY.

**T-8** Slide launch rod through rocket launch lug and place rocket on launching pad. Make sure the rocket slides freely on the launch rod. Clean the micro-clips and attach them to the igniter leads. Arrange the clips so they do not touch each other or the metal blast deflector.

**T-7** Clear the launch area, alert recovery crew and trackers. Check for low flying aircraft and unauthorized persons in the recovery area.

**T-6** Arm the launch panel -- INSERT SAFETY KEY.

**-5-4-3-2-1-LAUNCH!!**

**MISFIRE PROCEDURE**

Occasionally the igniter will heat and burn into two pieces without igniting the engine. This is almost always caused by a failure to install it correctly. Disarm the launch panel, remove the model, clean the igniter residue from the nozzle, and install a new igniter. Follow the launching procedure again.

# Sky Hook

**SKILL LEVEL 1 - Recommended for Beginning Rocketeers**

## BEFORE YOU START

Read all instructions before beginning work on your model. Make sure you have all parts and materials. When you are thoroughly familiar with the assembly procedure, begin construction. Check off each step as you complete it. In each step, test-fit the parts together before applying any glue. If some part doesn't fit properly, sand lightly or build up as needed for precision assembly.

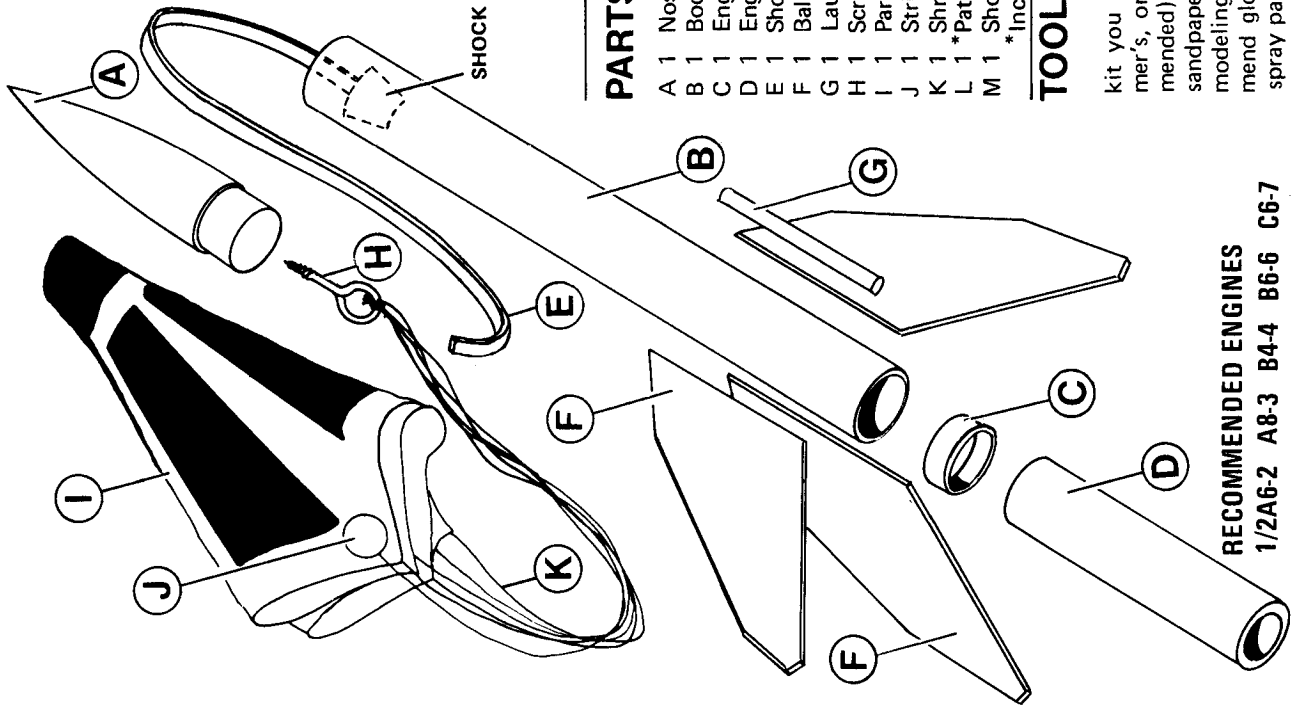

## PARTS LIST

Part	Description	Quantity
A 1	Nose Cone (BNC-30N)	70250
B 1	Body Tube (BT-30F)	30346
C 1	Engine Block (EB-30A)	30228
D 1	Engine Casing (EC-2)	35010
E 1	Shock Cord (SC-1B)	85734
F 1	Balsa Fin Stock (BFS-20)	32102
G 1	Launch Lug (LL-2B)	38178
H 1	Screw Eye (SE-1)	38251
I 1	Parachute (PK-12A)	85564
J 1	Strip Tape Discs (TD-3F)	38406
K 1	Shroud Line Cord (SLT-72)	38237
L 1	Pattern Sheet	82838
M 1	Shock Cord Mount (SCM-30)	84442

\* Included in kit but not illustrated.

## TOOLS AND MATERIALS

In addition to the parts included in this kit you will need white glue (Titebond glue, Elmer's, or similar household white glue is recommended), scissors, pencil, fine and extra-fine grit sandpaper, sanding sealer, masking tape, and a modeling knife. To paint your model we recommend gloss white and fluorescent orange enamel spray paint.

## RECOMMENDED ENGINES

- 1/2A6-2
- A8-3
- B4-4
- B6-6
- C6-7

# ASSEMBLY INSTRUCTIONS

**1** Fit the nose cone first. Insert the nose cone (part A) into one end of the body tube (part B). The nose cone should fit snugly enough so that it will be held in straight alignment, but loose enough so that only slight pressure is necessary to remove it. If it is too tight, sand the shoulder slightly. If the fit is too loose, wrap the shoulder with masking tape to bring it to a proper fit. Remove the nose cone and set it aside to use later in final assembly.

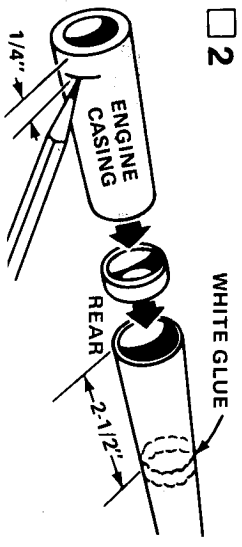

**2** The engine block (part C) is to be placed 2-1/2" from the rear of the rocket body. Mark the empty engine casing exactly 1/4" from one end and set it aside for a moment. Put a large dab of glue near the end of your little finger (or use a brush if you prefer) and spread the glue around the inside of the tube as far up as your finger will reach. Try not to get any glue near the very end of the tube or the engine block may "freeze" in the wrong place as you attempt to put it in place. Carefully insert the engine block just inside the end of the tube in which you have just spread the glue. Put the engine casing just marked against the engine block and push it forward into the tube until the mark on the casing is just even with the rear edge of the tube. The engine block will pick up enough glue as it passes up into place to anchor it in place securely. **CAUTION: DO NOT STOP** until it is in place and then remove casing immediately!

**3** Cut out the shock cord mount (part M). Crease it on the dotted lines by folding. Spread glue on the first section (1) and lay the end of the shock cord (part E) into the glue. Fold over and apply glue to the back of the first section and the exposed part of section 2. Lay the shock cord as

shown and fold over again. Clamp the unit together with your fingers until the glue sets.

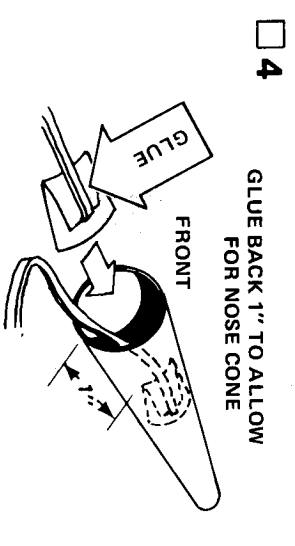
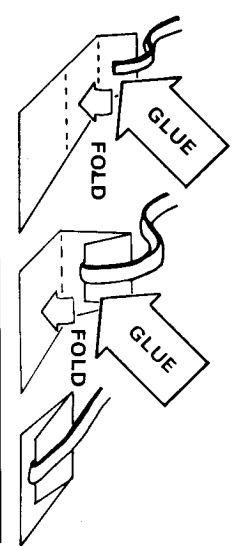

**4** Apply glue to the back of the shock cord mount. Press the mount into the body tube as shown allowing at least 1" for the nose cone and hold in place until the glue sets.

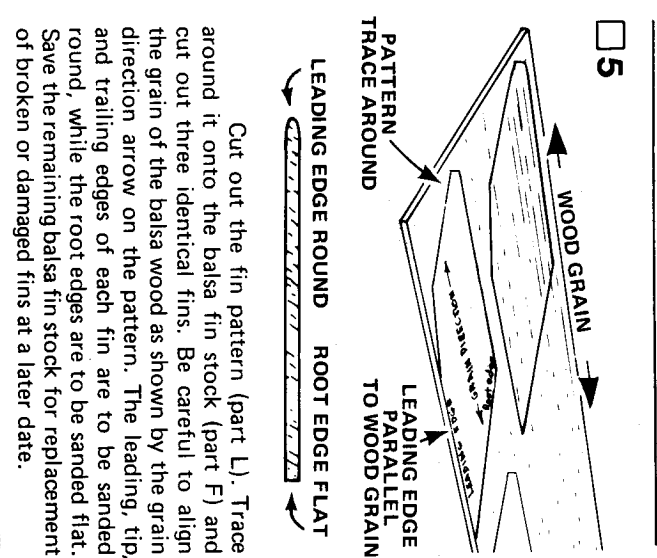

**5** Cut out the fin pattern (part L). Trace around it onto the balsa fin stock (part F) and cut out three identical fins. Be careful to align the grain of the balsa wood as shown by the grain direction arrow on the pattern. The leading, tip, and trailing edges of each fin are to be sanded flat, while the root edges are to be sanded flat. Save the remaining balsa fin stock for replacement of broken or damaged fins at a later date.

**6** GUIDE EVEN WITH BODY TUBE

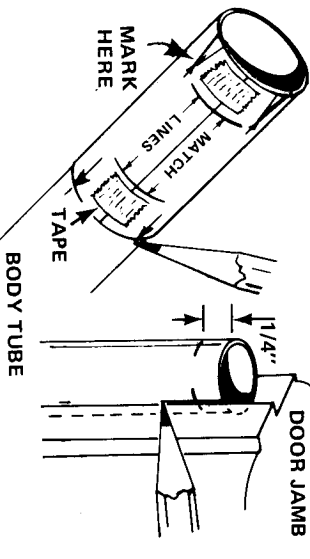

**7** Cut out the body tube marking guide. Wrap it around the rear end (the end into which you put the engine block) of the body tube so the arrow points are toward the front end of the tube — the rear edge flush with the rear edge of the tube as shown. Mark the tube at each of the six arrow points. Connect each pair of marks with a straight line drawn against door jamb as shown. Mark each line 1/4" from the rear of body tube.

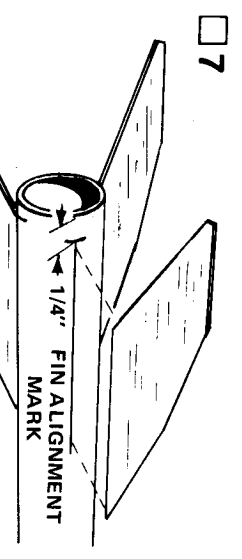

**8** Apply glue to the root edge of one fin and place it on one of the guide lines drawn in step 6. The rear tip of the root edge should be 1/4" from the rear edge of the tube. The fin should stick straight out from the body tube with the root edge parallel to the centerline (an imaginary line through the tube center, lengthwise) of the body tube. Hold fin until glue sets enough to support fin. Repeat this step with the other two fins.

**9** Trim launch lug even with the fin

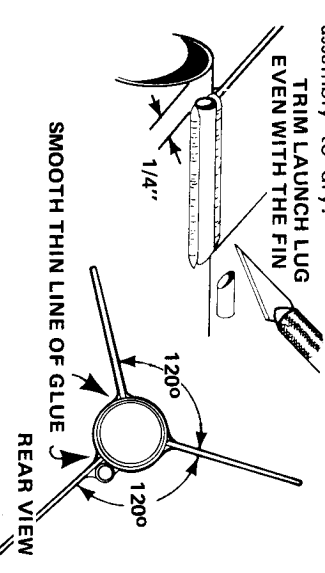

**10** Turn the screw eye into the center of the base of the nose cone — unscrew it, and squirt glue into the hole. **REPLACE THE EYE**

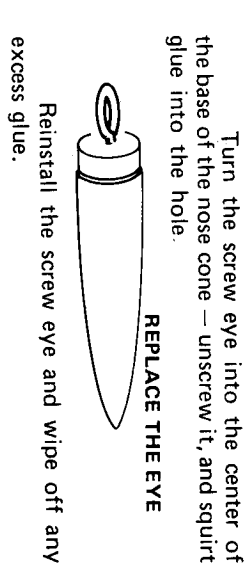

**11** Rub tape disc firmly onto parachute

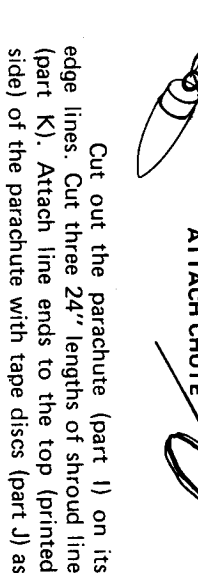

**12** Cut out the parachute (part I) on its edge lines. Cut three 24" lengths of shroud line (part K). Attach line ends to the top (printed side) of the parachute with tape discs (part J) as

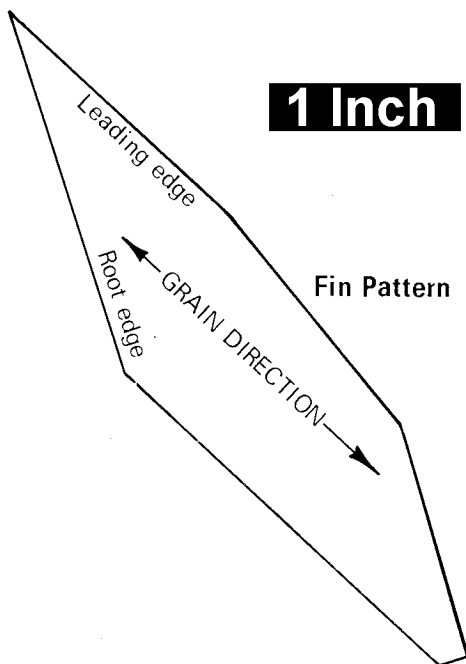
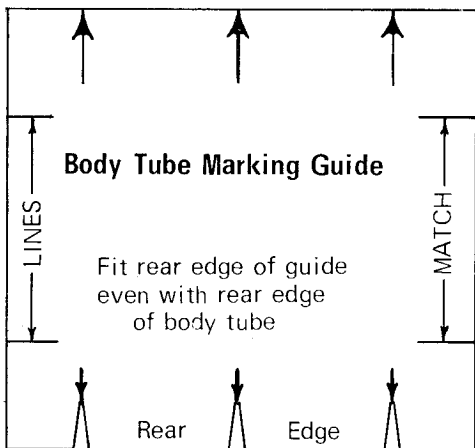

### CONSTRUCTION TIP

Your work will be more precise if you will use a straightedge to guide your cuts as you remove the parts from this sheet.



A DAMON COMPANY

**ESTES INDUSTRIES**  
**PENROSE, CO 81240 USA**

# Sky Hook



- Terrific Performance
- Easy to Build



## SKILL LEVEL

**1-Beginner** 2-Intermediate 3-Advanced 4-Dvanced 5-Expert

## SPECIFICATIONS

Length 12" (305 mm)  
Body Dia. 0.75" (19.1 mm)

Weight 0.7 oz. (20 g)  
Finish: Gloss

## RECOMMENDED IGNITERS

UG402 240 844 848 CS7  
Use UG402 for first flights.

This is a hobby kit requiring assembly.  
Launch system, igniter, pin and  
finishing supplies are not included.

# 1288

**ESTES**

**ESTES INDUSTRIES**  
PHOENIX, COLORADO, U.S.A.