

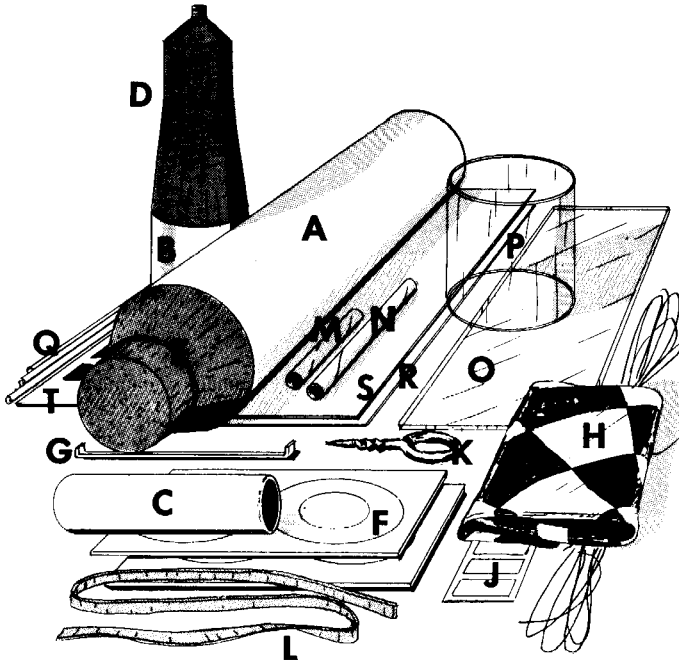

PARTS LIST



Your Saturn V semi-scale model rocket kit consists of the following parts as illustrated in the drawing at right:

- (A) 1 Body Tube--Part #BT-60AJ
- (B) 1 Body Tube--Part #BT-52AG
- (C) 1 Engine Mount Tube--Part #BT-20J
- (D) 1 Nose Cone--Part #BNC-52AG
- (E) 1 Balsa Adapter--Part #TA-5260A
- (F) 4 Adapter Rings--Part #RA-2060
- (G) 1 Engine Holder--Part #EH-2
- (H) 1 12" Parachute--Part #PK-12A
- (I) 72" Shroud Line Cord--Part #SLT-12
- (J) 6 Tape Strips--Part #TD-2F
- (K) 1 Screw Eye--Part #SE-2
- (L) 1 Shock Cord--Part #SC-1
- (M) 1 Launching Lug--Part #LL-2A
- (N) 1 Launching Lug--Part #LL-2B
- (O) 1 Sheet Plastic Fin Material--Part #CFS-40
- (P) 1 Plastic Tube--Part #JT-60P
- (Q) 3 1/12" Diameter Wood Dowels--Part #WD-2
- (R) 1 Fin "Stick-On"--Part #SP-39A
- (S) 1 Wrap-On Sheet--Part #SP-39B
- (T) 1 Pattern Sheet--Part #SP-39C

In addition to the materials included in your kit you will also need the following parts and tools:

1. Modeling knife or single edge razor blade
2. Extra strong white glue.
3. Scissors
4. Clear Butyrate Dope
5. Fine and extra fine grit sandpaper
6. Pencil or ball point pen
7. Sanding sealer and brush-on paint or dope

DO NOT USE BUTYRATE DOPE OVER SPRAY ENAMELS!

Read the entire assembly instructions carefully before beginning work on your rocket. Then start construction, following each step in order, checking off each step as it is completed.

ASSEMBLY INSTRUCTIONS

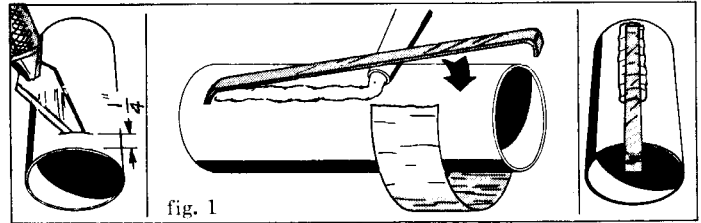

1. Measure 1/4 inch from one end of the BT-20J engine mount tube and punch a slot for the forward hook of the EH-2 engine holder. Spread a 1" long line of glue along the tube, from the slit toward the rear, where the engine holder will fit. Hook one end of the EH-2 engine holder into the slit and lay in into the line of glue. Hold the engine holder in place with a strip of tape while the glue hardens.

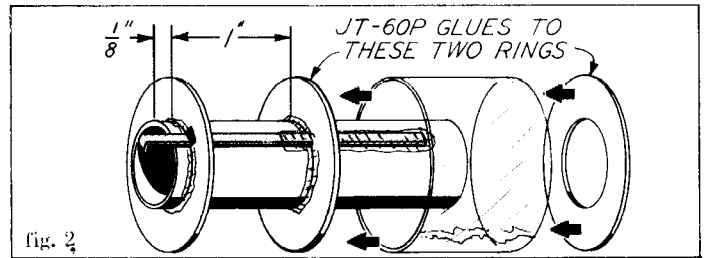

2. Punch out three of the 20-60 paper adapter rings. (Don't throw the cards away--they'll be needed later in step #8.) Make a 1/8" square notch on the inside of one of the rings. Slip this ring onto the rear end of the engine holder tube, positioning it so the notch is over the engine holder and the ring is about 1/8" from the end of the tube. Slip the second ring onto the other end of the tube, positioning it one inch from the first ring. Run a fillet of glue around both ring-tube joints, making sure no glue gets into the notch in the first ring. Put the plastic tube in place as shown in the drawing. Slip the third 20-60 ring onto the engine mount tube so it holds the plastic tube against the second ring. Run a fillet of glue around the ring-tube joint and set the assembly aside to dry.

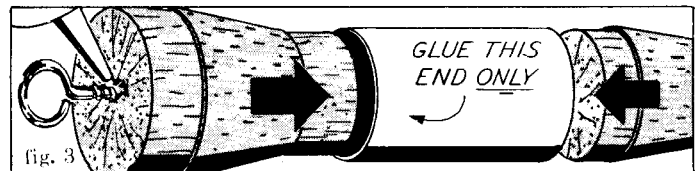

3. Spread glue around the inside of one end of the BT-52AG body tube and slip the small end of the TA-5260 adapter into this end of the tube. Slip the BNC-52AG nose cone into the other end of the tube. Do not glue the nose cone in place. Turn the screw eye into the center of the adapter. Remove the screw eye, squirt glue into the hole, and replace the eye.

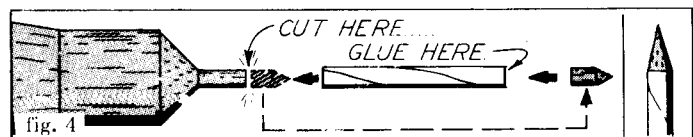

4. Cut the tip from the BNC-52AG nose cone as shown. Glue the LL-2A launching lug (the shorter one) to the main part of the nose cone and glue the tip piece into the other end as illustrated.

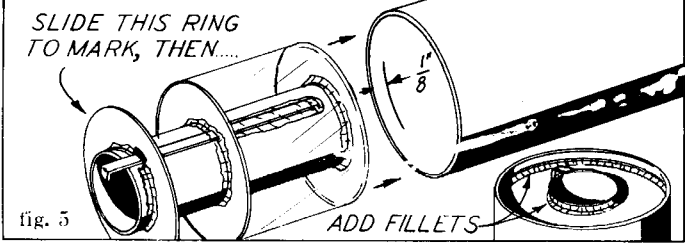

5. Draw a line around the inside of the BT-60AJ body tube, 1/8 inch from the end of the tube. Slip the engine mount assembly into the body until the rear ring is even with the line. Spread a glue fillet around the joint of the body tube and the rear ring. Holding the body in a vertical position, drip glue onto the upper ring and spread the glue around the ring-tube joint with a length of dowel, artist's paint brush or similar tool. Support the assembly in a vertical position while the glue dries.

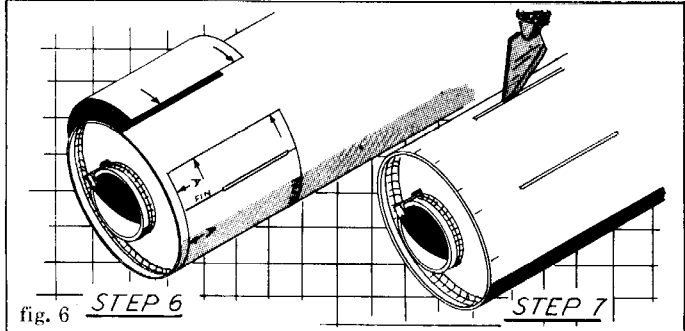

6. Carefully cut out the tube marking guide. Cut out the "FIN SLOT" areas. Wrap the guide around the rear of the body tube with the rear of the guide at the rear of the tube. Mark the tube at each of the indicated positions. The positions marked "A" indicate the ends of the engine shroud formers. Remove the marking guide and extend the marks up the tube to a point beyond where the upper edge of the fin will go.

7. Very carefully cut out the fin slots from the body tube. The plastic tube is under the area of the slots, so cut lightly to avoid damaging the plastic.

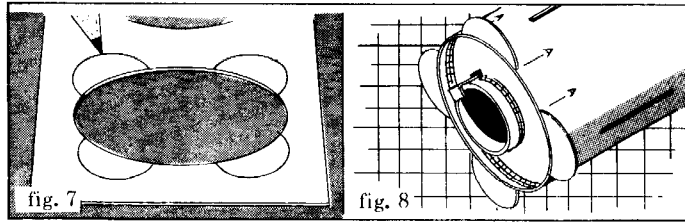

8. Cut out the shroud former pattern from the pattern sheet. Place it on the card that the 20-60 rings were punched from as shown in fig. 7. Four formers will be needed. After tracing around the pattern, cut out the formers. Spread glue along the inside edge of one of the formers and center it on a fin line between two of the shroud former lines. Make sure the formers are even with the end of the tube.

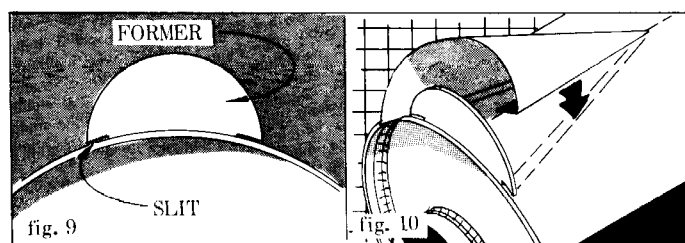

9. Cut out the four engine shrouds. Roll the shrouds around the sharpened end of a pencil to form a half cone. Fold the glue tabs under. Using the tip of a modeling knife or the corner of a razor blade, cut a small slit under the edges of the shroud formers. Spread glue along one of the glue tabs on one of the engine shrouds. Hook the end of the glue tab under the edge of the former and lay the tab onto the body tube so that the tip of the shroud is centered on the fin line. Spread glue on the remaining tab and roll the shroud around the former, tucking the tab under the edge of the former. Repeat this step with the remaining shrouds.

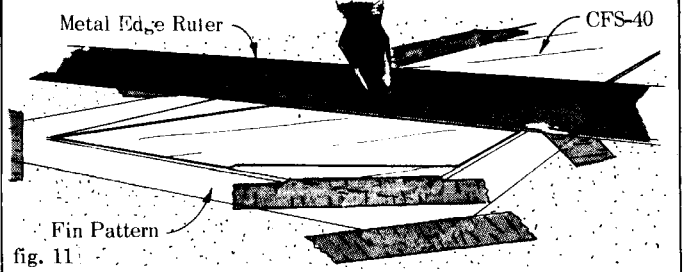

10. Cut out the square containing the fin pattern on the dotted line. Tape the square to your cutting board. Place the CFS-40 fin stock over the pattern and tape in place as shown above. Using a metal edge ruler make several cuts along the edge lines of the fin. Remove the fin stock from the pattern and snap out the fin. Repeat this step to make the other three fins.

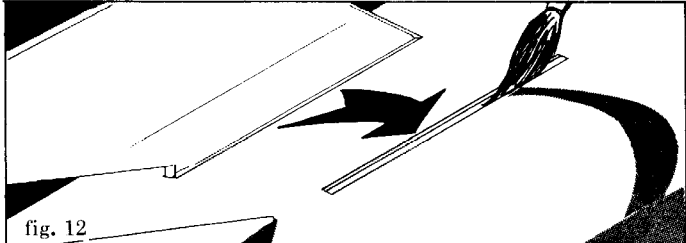

11. With the tip of a small brush, apply a generous amount of clear dope in one of the fin slots. Insert the root edge of a fin into the slot and hold it in place for a few minutes to give the dope a chance to dry, gluing the fin in position. If you were careful when you cut the fin slots the fin will automatically be aligned correctly—but check to be sure anyway. Repeat this step with the other three fins.

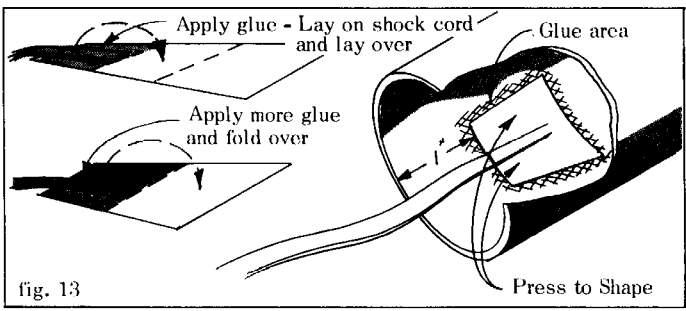

12. Cut out the shock cord mount. Prefold it on the dotted lines, then flatten it out. Smear glue over section 1. Lay the end of the shock cord in place and fold section 1 over. Apply glue to the back of section 2 and fold again. Clamp the unit together with your fingers while the glue sets. Apply glue to the inside of the body tube over an area approximately 1" to 2" from the front end. The glue should cover a shape approximately the same as the shock cord mount. Press the mount onto the glue and hold it until the glue sets.

PLEASE STUDY FIGURES 14 AND 15 AT TOP OF NEXT PAGE BEFORE DOING NEXT STEPS.

13. Attach the wrap-ons in the order shown in fig. 14. Do not cut out a wrap-on until you are ready to put it in place. Starting with wrap-on #1, cut it out and spread a thin layer of white glue on the back side. Wrap it around the upper end of the BT-52 body tube so the front edge of the wrap-on is 0.15" (1/8") from the front edge of the body tube. Wrap-on #2 covers the 52-60 adapter. Cut out the wrap-on and check its fit on the adapter. If necessary, sand the balsa until the wrap-on fits perfectly. Apply glue to the back of the wrap-on and attach it in place. The rear edge of wrap-on #3 fits against the front of wrap-on #2.

14. Attach wrap-on #4 to the BT-60 body tube at its front. Mark the body 2-7/8 inches from its front end. This mark is the position of the front edge of the #5 wrap-on. Glue #5 on place with the dividing lines between black and white sections straight ahead of the fins so a black area is ahead and to the left of a fin position and a white area is ahead and to the right of the fin position. Attach #6 so its rear edge is even with the front edges of the fins. Finally, cut out the four sections of wrap-on #7. These sections are glued between the engine shrouds. The rear edges of the #7 pieces should be even with the rear edge of the tube.

15. Glue the LL-2B launching lug to the body tube between wrap-ons #5 and #6. Position the lug so it is 1/4" to the left of a dividing line on one of the #7 wrap-ons as shown.

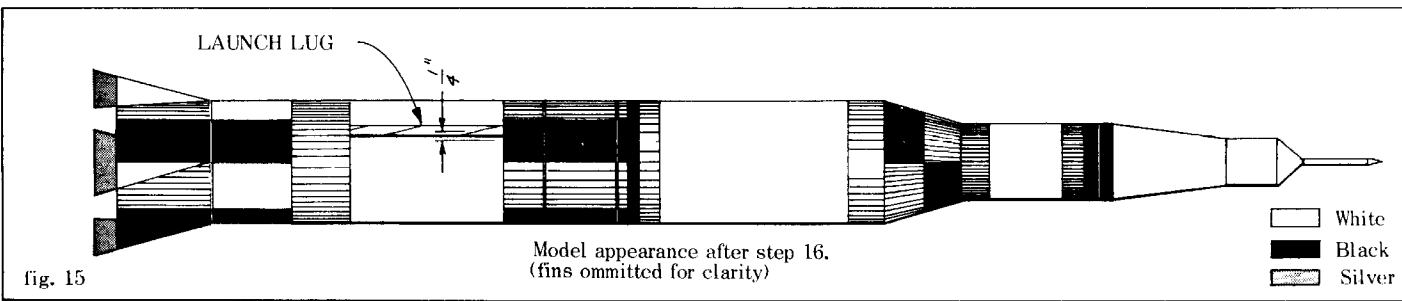
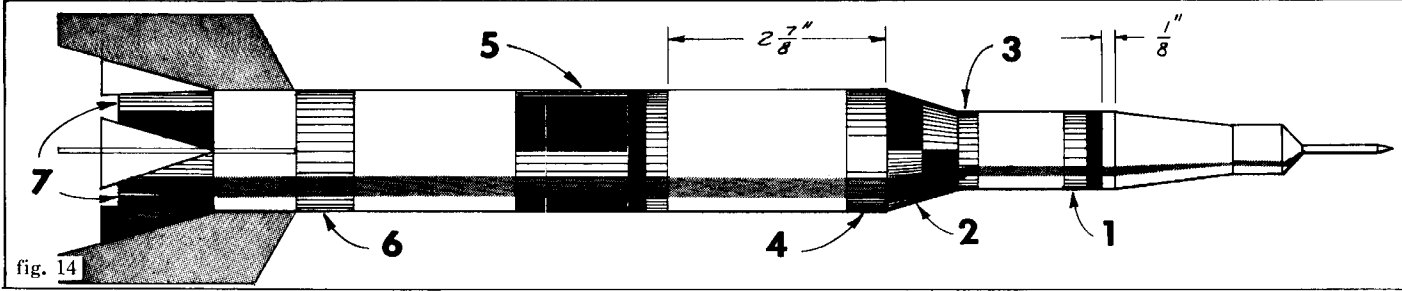

16. Most of the painting on this model is taken care of by the wrap-ons. It is still necessary to paint the nose cone and the areas between the wrap-ons. All areas are painted white except the section between wrap-ons #6 and #7. Between these two wrap-ons the paint pattern follows the pattern of wrap-on #7—white above the wrap-on's white area and black above black. This pattern is carried out over the engine shrouds, too. The left half of each shroud down to the rear of the body is painted black. Below the rear of the body the shroud should be painted silver. The short section of tube above wrap-on #1 is painted black. Brush-on dope or enamel paint is recommended for this model.

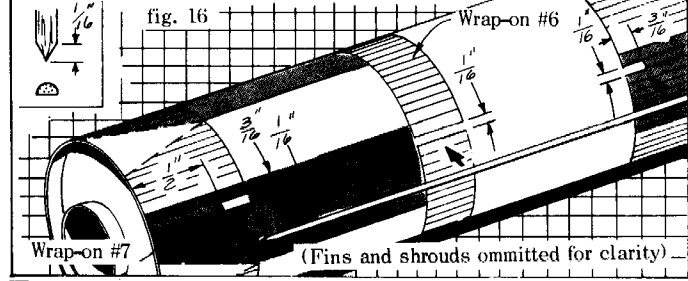

17. Install the systems tunnels. To do this, scrape or sand one piece of WD-2 dowel to the half-round section shown in the upper corner of the illustration. Cut two 5 inch lengths from this dowel and sand the ends to a point as shown in the upper corner of fig. 16. Cut out and peel off the sections of the wrap-ons which will be under the dowel as shown. Spread glue in the areas you have just cut out and lay one of the 5 inch systems tunnels into it. Repeat this step on the other side of the rocket, directly opposite the first tunnel.

18. Sand down one side of one dowel slightly as shown in the upper corner of fig. 16. Cut eight pieces from this dowel, each 9/16" long. Point the front end of each piece as illustrated in the lower corner of fig. 17 (Ullage Motor). Apply glue to the bottom of one of these ullage motor pieces and attach it to wrap-on #5 in the position shown, 7/16" from the rear of the wrap-on and at the edge of a white area. The next motor goes on the edge of a black area, the same distance from the rear of the wrap-on, followed by one on the right edge of a white area, etc. Continue this procedure with the remaining ullage motors.

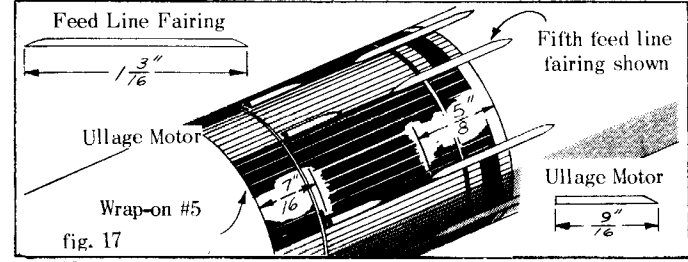

19. Form 5 feed line fairings to the shape illustrated in the upper corner of fig. 17. Scrape or sand the bottom of a dowel to flatten it slightly, then cut 5 pieces 1-3/16" long and point the ends. Spread glue on the flat side of one feed line fairing. This fairing goes on wrap-on #5. Install a feed line fairing above each fin. The fifth fairing goes half-way between two of the others.

20. Using a very fine brush, painting the ullage motors and feed line fairings white. The systems tunnels are painted white where they pass through a white area and black where they pass through a black area.

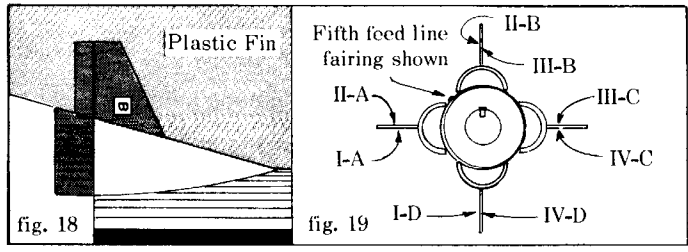

21. Cut out fin #II-B around its edge and strip off the backing paper. Attach the paper fin to the plastic fin that is located just right of the fifth feed line fairing. The line on the paper fin should be lined up with the rear edge of the body tube. Fin #II-A attaches to the plastic fin which is just to the left of the fifth feed line fairing. Apply the other fins in the same way, checking their positions against the front view above.

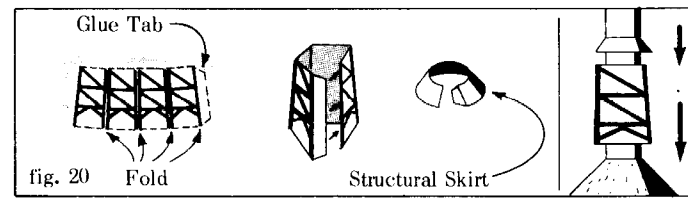

22. Cut out the tower as shown in fig. 20. Fold the tower at the points indicated to form a box. Spread glue on the glue tab and tuck the tab behind the free end of the box. Cut out the "structural skirt", roll into a cone, and glue. After these pieces have dried, slip the tower over the "escape motor" on the front of the nose cone. Spread glue around the upper edge of the tower and slide the skirt into place on top of the tower.

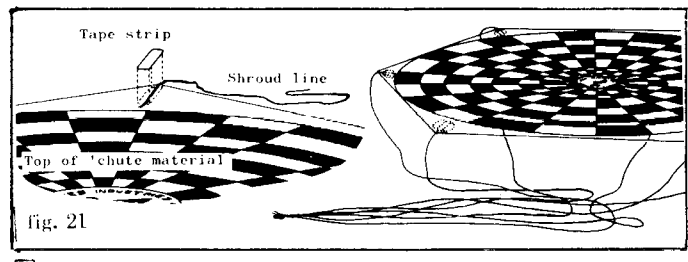

23. Cut out the parachute along its edge lines. Cut six pieces of shroud line, each twelve inches long. Lay the end of a shroud line on the spot indicated at the corner of the "chute" and secure it in place with tape strip as shown. Tie the free ends of the shroud lines together, then tie them to the screw eye in the base of the TA-5260A adapter. Tie the shock cord to the screw eye.

COUNTDOWN CHECKLIST

While your Saturn V model will fly with a payload of up to 1 ounce weight, it is not necessary to include anything in the payload section when launching. Be sure the nose cone fits tightly before flying — especially if there is a payload aboard. The engines recommended for this model are the A8-3, B6-4 and C6-5. Use A8-3 engines for the first test flights.

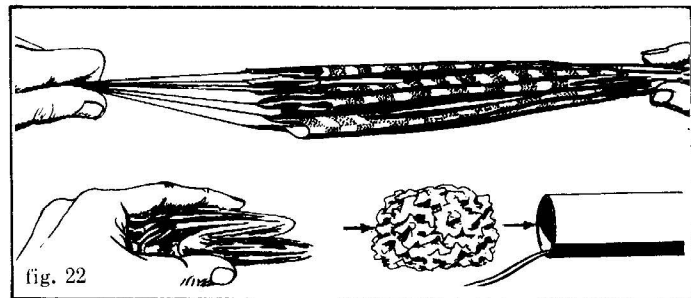

10. Pack flameproof wadding into the body tube. The wadding should extend about one and one-half inches up the tube. Fold the parachute carefully and pack it on top of the wadding. Pack the shroud lines and shock cord on top of the 'chute and slide the nose cone assembly into place.

9. Insert an igniter in the engine as directed in the instructions that came with the engines. Slip the engine into place in the engine mount.

8. Place the rocket on the launcher, clean the micro-clips and attach them to the igniter wires.

7. Clear the area. Check for low flying aircraft. Alert your recovery crew and trackers.

6. Arm the launch panel.

-5- -4- -3- -2- -1- LAUNCH!

SATURN V DATA

Overall Data

Saturn V (Directed by Marshall Space Center-NASA)

Height — 364.5 feet
Diameter — 33.0 feet
Weight (Net) — 6,100,000 pounds
Payload Limits — 285,000 pounds
into earth orbit
98,000 pounds into
Lunar trajectory

S-1C Stage (The Boeing Company)

Height — 138 feet
Diameter — 33 feet
Engines — 5 Rocketdyne F-1
Propellants — Liquid Oxygen (346,400 gal.)
Kerosene (RP-1) (214,200 gal.)
Thrust — 1,500,000 pounds per engine
(7,500,000 pounds total)
Stage Burn Time — 150 seconds

S-1IC Stage (North American Rockwell Corp.)

Height — 81.5 feet
Diameter — 33 feet
Weight (loaded) — 1,064,000 pounds
Engines — 5 Rocketdyne J-2
Propellants — Liquid Hydrogen and Liquid Oxygen
Thrust — 200,000 pounds per engine
Stage Burn Time — 360 seconds

S-1VB Stage (McDonnell Douglas Corp.)

Height — 58.0 feet
Diameter — 21.7 feet
Weight — 265,000 pounds
Engine — 1 Rocketdyne J-2
Propellants — Liquid Hydrogen and Liquid Oxygen
Thrust — 200,000 pounds
Stage Burn Time — 120 seconds (approx.)

Service Module (North American Rockwell Corp.)

Height — 22 feet
Diameter — 13.8 feet
Weight — 55,000 pounds
Propellants — Hypergolic
Thrust — 22,000 pounds
Engine can be stopped and re-started up to 50 times.

Command Module (North American Rockwell Corp.)

Height — 12 feet
Diameter — 13.8 feet at base
Weight — 13,500 pounds

Launch Escape System (North American Rockwell Corp.)

Height — 33 feet
Weight — 8200 pounds
Diameter — 26 inches
Escape Motor Thrust — 150,000 pounds

Apollo 11 rises past the launch tower at pad 39A to begin man's first lunar landing mission.

Photo Credit — NASA

* Print at 600dpi *



A SUBSIDIARY OF DAMON

SP-39B

SATURN V

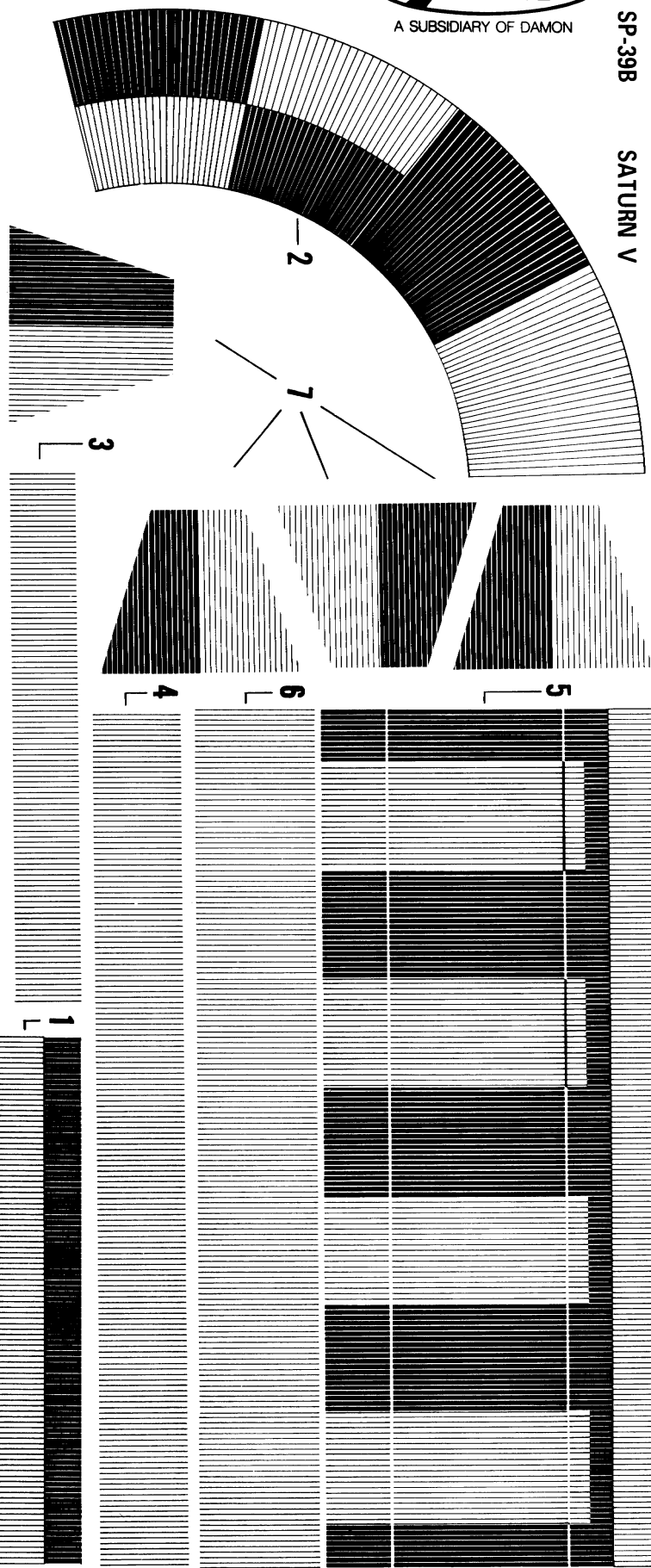



A SUBSIDIARY OF DAMON

ENGINE SHROUDS

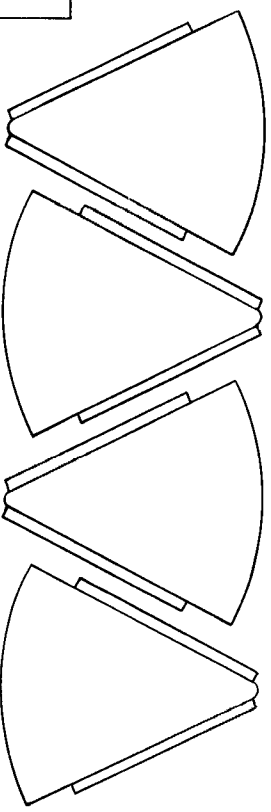

STRUCTURAL SKIRT



SHROUD FORMER

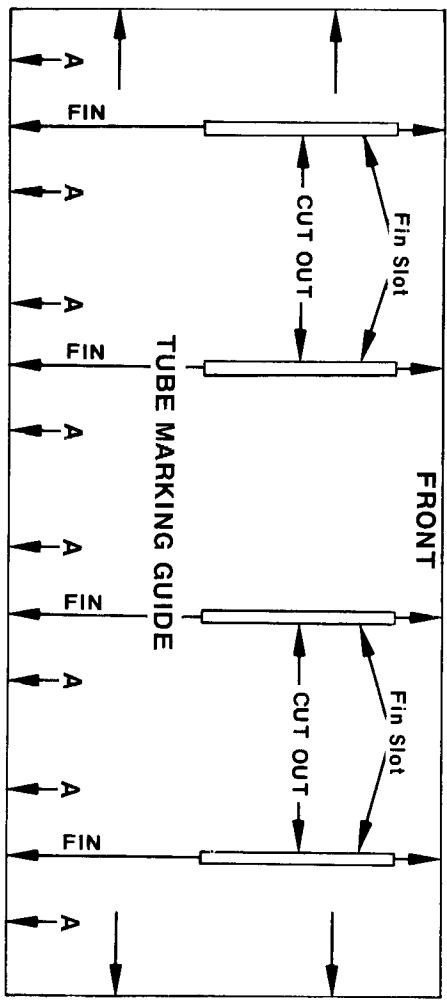
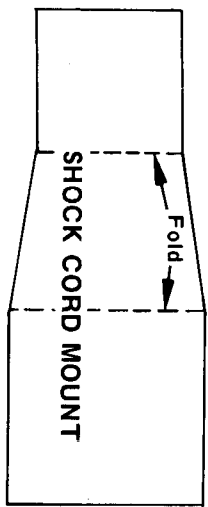

FIN PATTERN

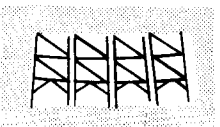
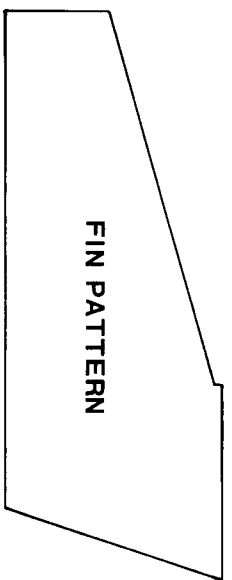

TOWER

cut out just inside grey area

II-A



I-A



III-B



II-B · IV-C



III-C



I-D

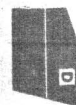

IV-D



SP-39A

