





A SUBSIDIARY OF DAMON
ESTES INDUSTRIES
 PENROSE, COLO. 81240

NIKEX

ASSEMBLY INSTRUCTIONS

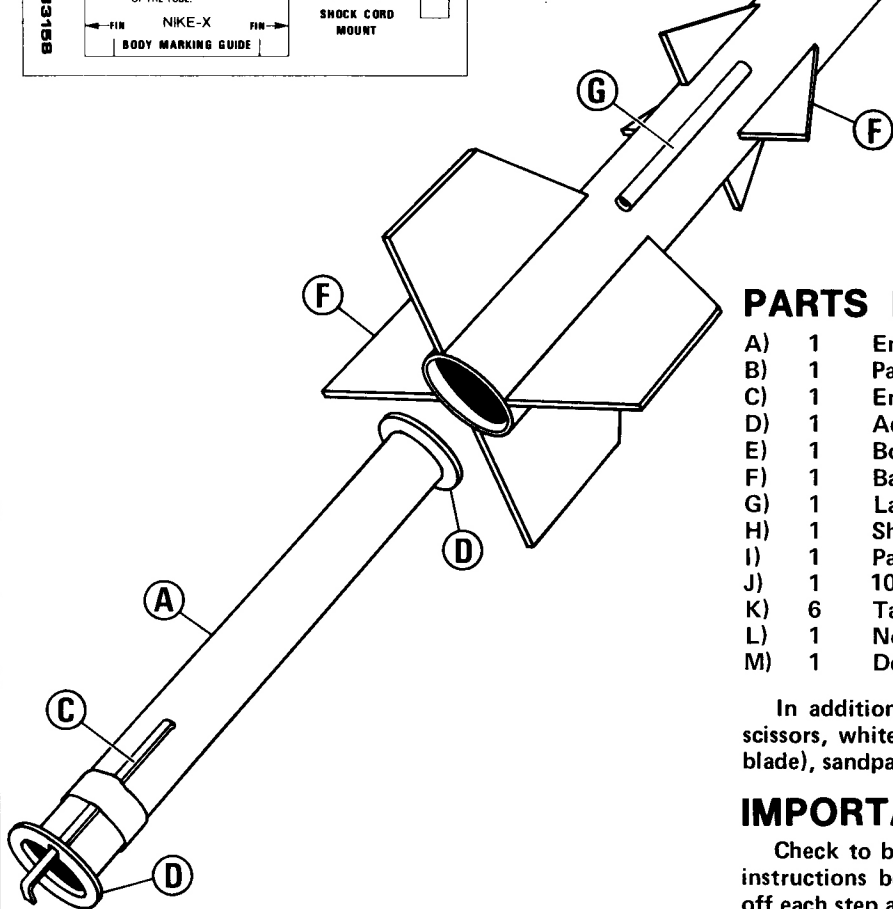
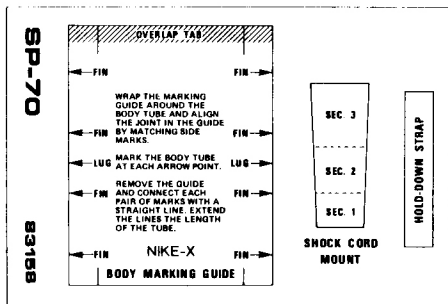
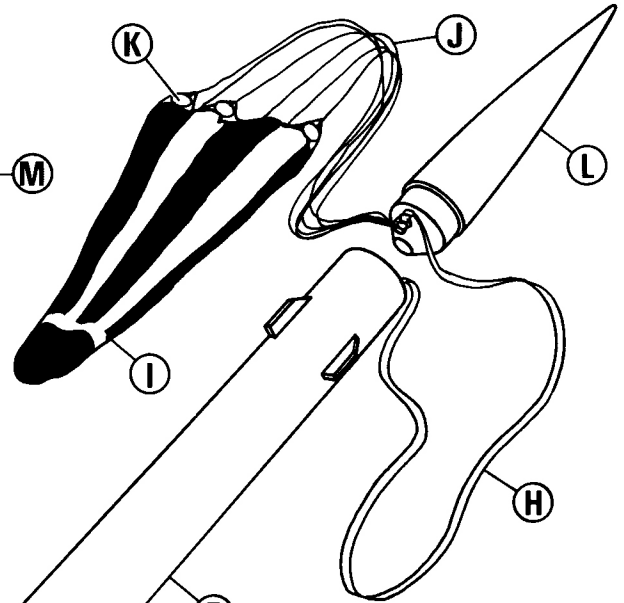
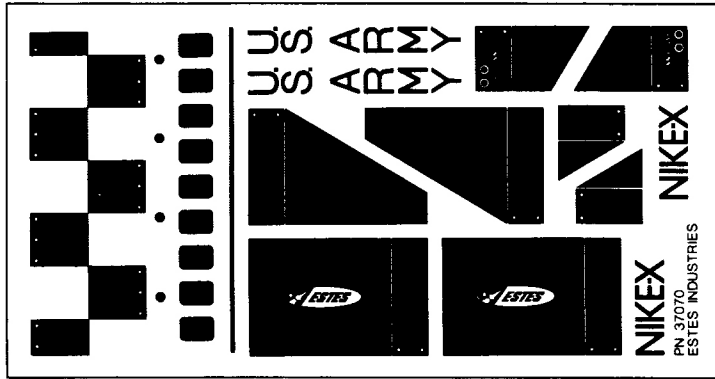

PARTS LIST

A)	1	Engine Mount Tube type BT-20B	30320
B)	1	Pattern Sheet type SP-70	83158
C)	1	Engine Hook type EH-2	35025
D)	1	Adapter Ring Set type RA-2055	30126
E)	1	Body Tube type BT-55	30382
F)	1	Balsa Fin Sheet type BF-70	32282
G)	1	Launch Lug type LL-2B	38178
H)	1	Shock Cord type SC-1	85730
I)	1	Parachute type PK-18A	85566
J)	1	108" Shroud Line Cord type SLT-108	38239
K)	6	Tape Discs type TD-3F	38406
L)	1	Nose Cone type PNC-55AC	71070
M)	1	Decal type KD-70	37070

In addition to the parts included in this kit you will need scissors, white glue, a sharp model knife (or single edge razor blade), sandpaper, sanding sealer, and paint.

IMPORTANT:

Check to be sure your kit is complete, then read the entire instructions before beginning to assemble your rocket. Check off each step as you complete it.

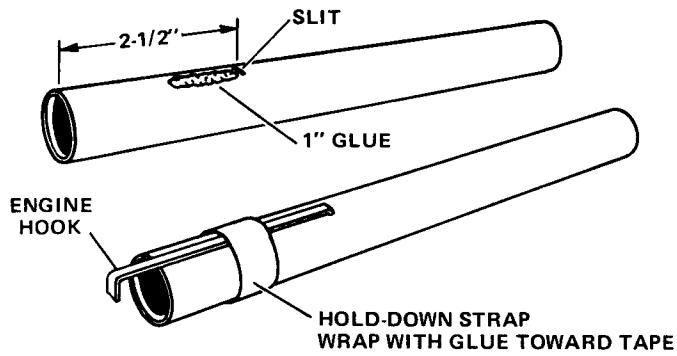

1 Mark the engine mount tube (part A) 2-1/2" from one end. Cut a 1/8" long slit in the tube at the mark as shown. Cut out the hold-down strap from the pattern sheet (part B). Apply a 1" long line of glue to the tube as shown. Push one end of the engine hook (part C) into the slit and press the main part of the hook into the glue. Apply glue to one side of the hold-down strap and wrap it tightly around the middle of the tube over the engine hook.

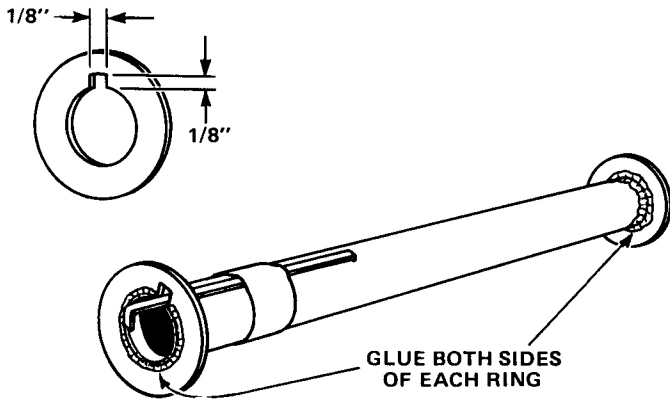

2 Punch out the adapter rings (part D) from the die-cut card. Cut a 1/8" square notch in one ring as shown. Slide the notched ring onto the end of the engine mount tube from which the hook projects. Slide the other ring onto the opposite end of the tube. Apply a line of glue at the ring/tube joint on both sides of each ring. Let this assembly dry.

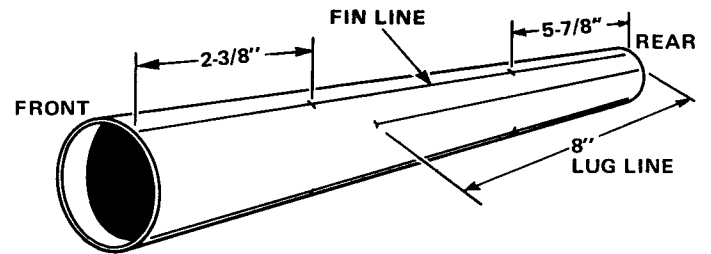
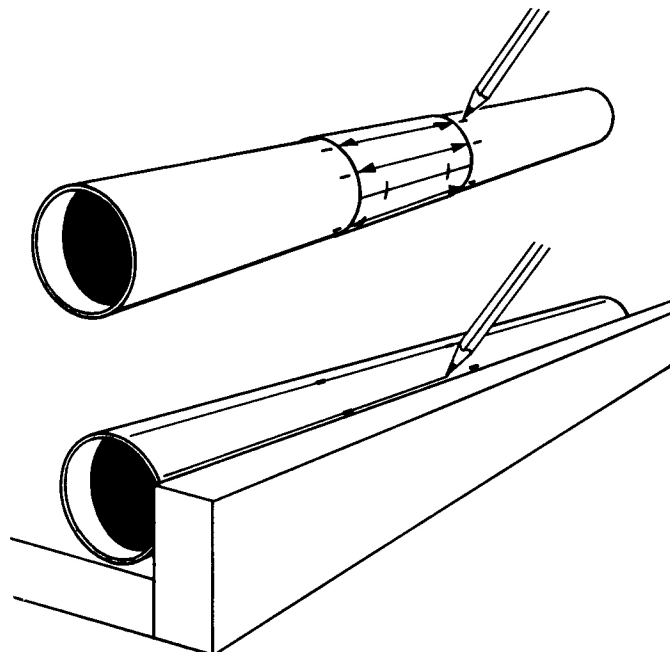

3 Cut out the tube marking guide and wrap it around the body (part E). Mark the body tube at each of the arrow points. Draw straight lines the length of the tube through each fin mark. Draw a straight line 8" forward from the rear of the body at the launch lug mark. Use the edge of a drawer front or a door frame as a guide to keep the lines straight on the body. Mark the fin lines 5-7/8" from rear end of the body and 2-3/8" from front end.

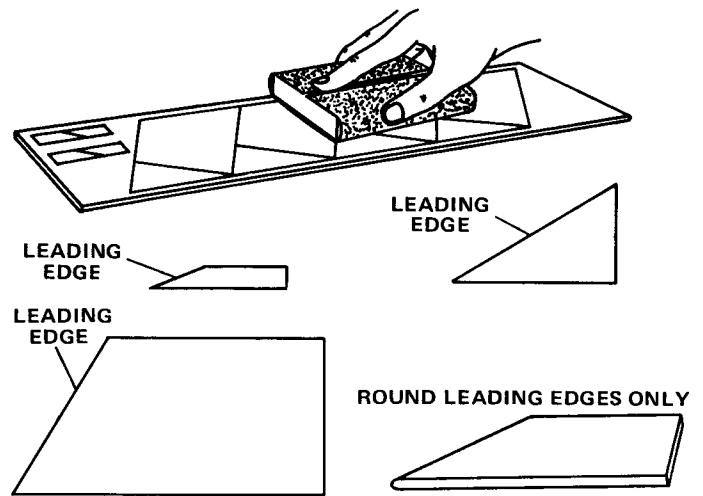

4 Fine sand the balsa sheet (part F), then carefully remove the die-cut fins from the sheet. Free the edges with a sharp knife. Sand the leading edges of the fins round. Leave all other edges square.

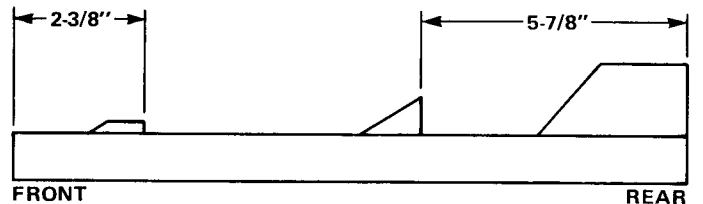

5 Rub a line of glue into the root edge of each fin and allow to dry. Glue the fins to the body on the alignment lines drawn in step 3. Refer to the illustration to be sure you mount the fins in the correct positions. Adjust the fins so they project straight away from the body tube. Do not set the rocket on its fins while the glue is wet.

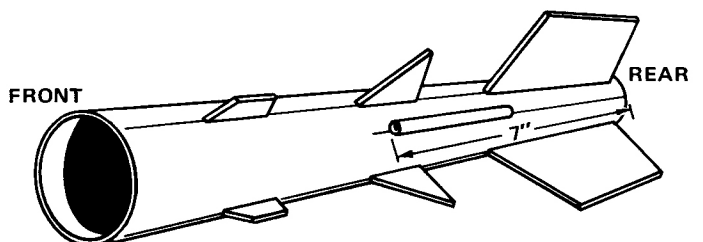

6 Glue the launch lug (part G) to the body on its line. The front of the lug should be 7" from the rear of the body. Align it straight on the body.

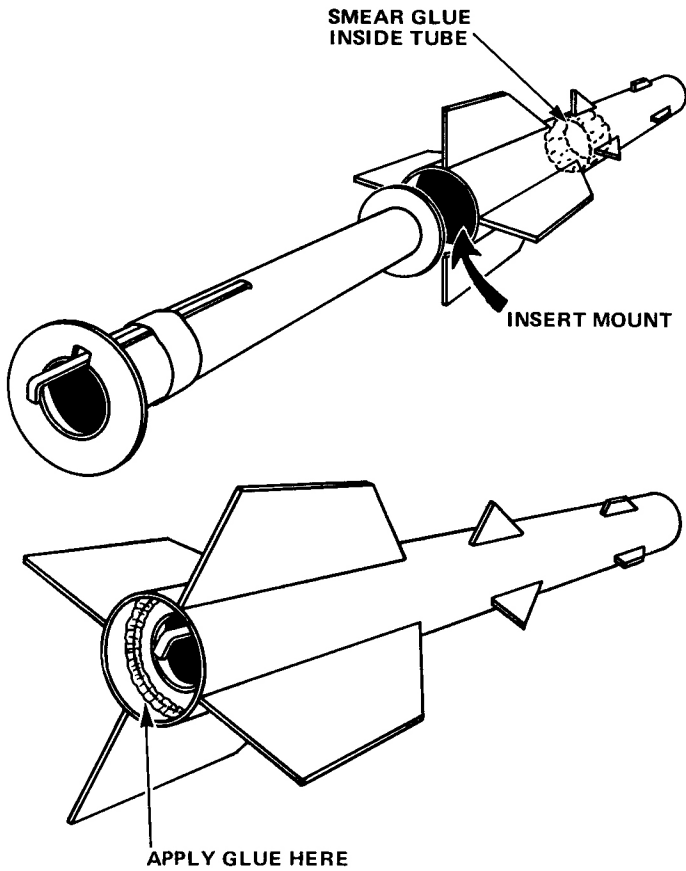

7 Smear glue around the inside of the body tube rear as far in as possible (but not more than 8-1/2" in). Immediately insert the engine mount unit, being careful to aim it so the engine hook will be at the rear. Push the engine mount in with one smooth motion until the end of the hook is even with the end of the tube. Apply a line of glue to the joint between the rear ring and the body. Set the rocket on its forward end while the glue dries.

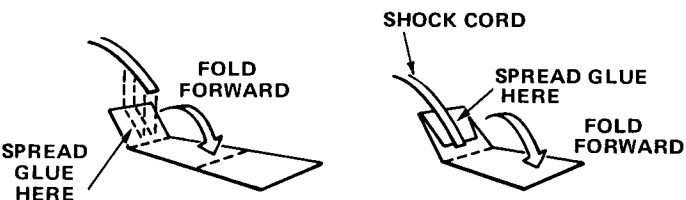

8 Cut out the shock cord mount from the pattern sheet. Pre-fold it on the dotted lines. Apply glue to section 1 and lay the shock cord (part H) into the glue. Fold over and apply glue to the back of the first section and the exposed part of section 2. Lay the shock cord as shown and fold over again. Clamp the unit together with your fingers until the glue sets.

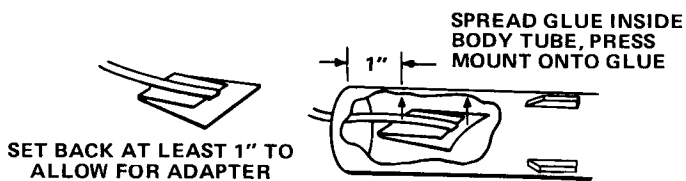

9 Apply glue to the inside of the body at the front over an area about 1" to 2" from the end. The glued area should be the same size as the shock cord mount. Press the mount into the glue as shown and hold it until the glue sets.

FILLETS SHOWN ARE SLIGHTLY EXAGGERATED

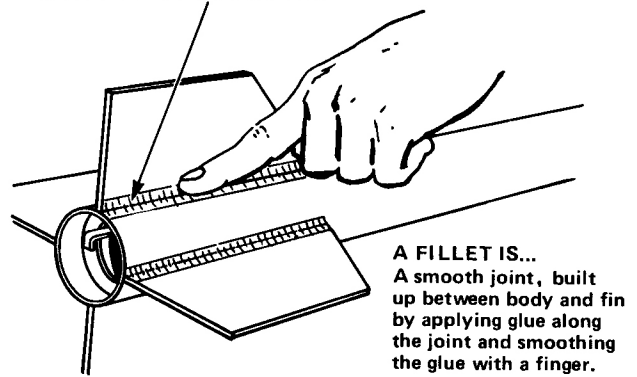

10 Apply a glue fillet to each fin joint. Holding the rocket horizontally, apply a line of glue to the joint and smooth it out with your finger. Support the rocket horizontally until the glue dries.

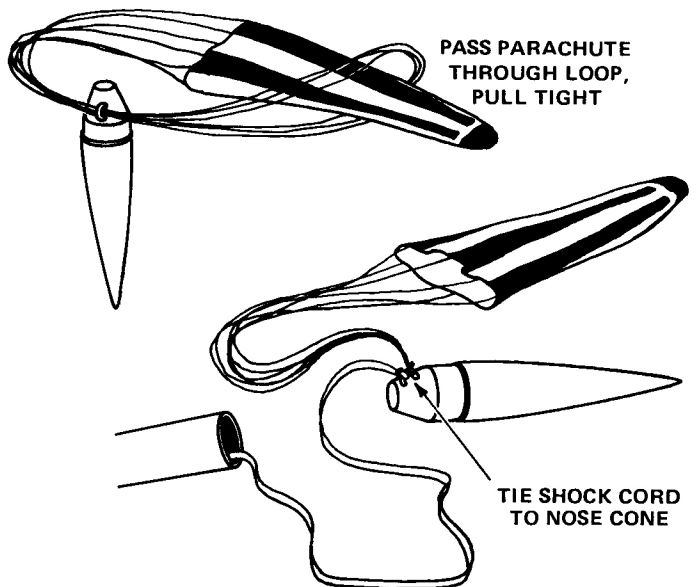
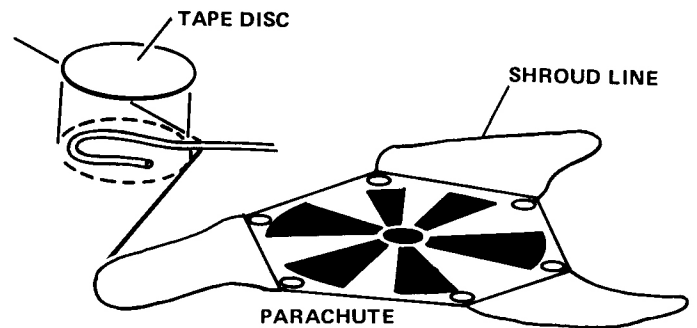

11 Cut out the parachute (part I) on its edge lines. Cut three 36" lengths of shroud line (part J). Attach line ends to top surface of parachute with tape discs (part K) as shown. Pass shroud line loops through ring on nose cone (part L). Pass parachute through loop ends and draw lines tight against ring. Set knot with a drop of glue. Tie free end of shock cord to nose cone.

12 Apply two or more coats of sanding sealer to all balsa surfaces. Sand lightly with extra fine sandpaper between coats. Repeat until pores are filled and surfaces look and feel smooth. Paint entire rocket white. Paint inside of body tube and ring at rear red.

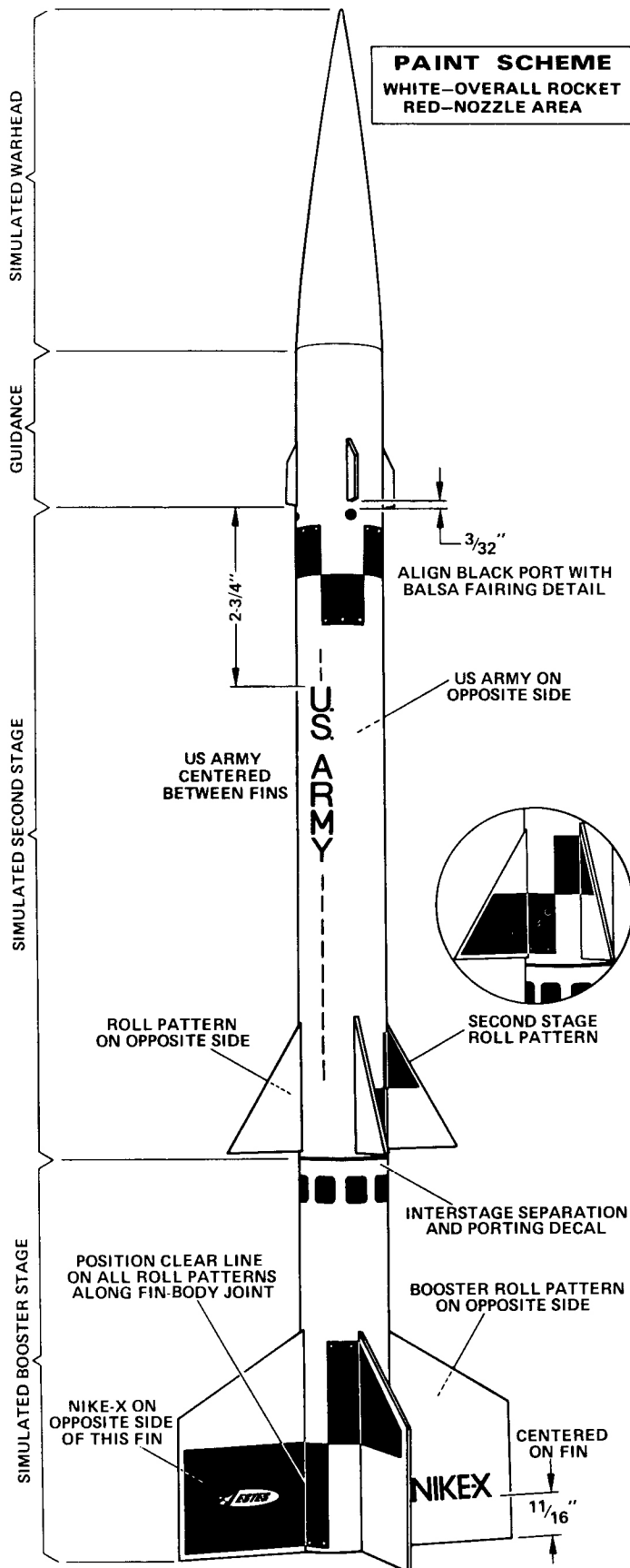

13 When all paint is dry, apply decals (part M). Cut out a decal section, dip it in lukewarm water for 10 seconds, and hold it until it uncurls. Slip the decal off the backing sheet and onto the model. Blot excess water away. For best results, let the model dry overnight and apply a coat of clear spray to protect the decals.

COUNTDOWN CHECKLIST

14 Pack eight to ten squares of crumpled recovery wadding loosely into body tube.

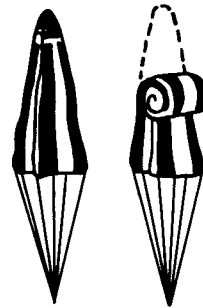

FOLD AND WRAP SHROUD LINES AROUND PARACHUTE

INSERT AFTER WADDING

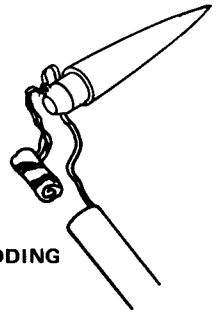

13 Fold the parachute into a triangular shape. Roll 'chute tightly as shown and wrap shroud lines around it. If 'chute is too large, unroll it and repack until it slides easily into rocket. A fit that is too tight may prevent parachute from ejecting properly.

12 Pack shock cord neatly into rocket.

NOTE: DO NOT pack parachute until you are actually ready to launch. For maximum parachute reliability, lightly dust the 'chute with ordinary talcum powder before each flight, especially in cold weather.

Slide nose cone into place. Nose cone should separate easily from rocket body tube, but should not be extremely loose. If it is too tight, sand inside of body tube end and shoulder of nose cone with extra fine sandpaper.

If nose cone is too loose, add a wrapping of transparent tape or masking tape to the shoulder of the nose cone.

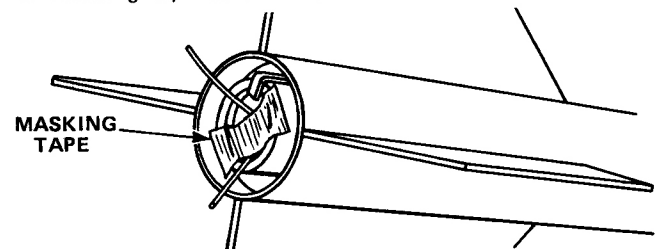

11 Select an engine and install an igniter as directed in the engine instructions. Engines recommended for use with this rocket are A8-3, B4-4, B6-4, and C6-5.

10 Insert engine into rocket. Engine hook must latch securely over end of engine.

9 Disarm the launch panel---remove safety key.

8 Place rocket on launch pad, making sure rocket slides freely on launch rod. Clean the micro-clips and attach them to the igniter.

7 Clear the launch area, alert recovery crew and trackers. Check for low flying aircraft and unauthorized persons in the recovery area.

6 Arm the launch panel---insert safety key.

5 4 3 2 1 LAUNCH!!

MISFIRE PROCEDURE

Occasionally the igniter will heat and burn in two without igniting the engine. This is almost always caused by a failure to install it correctly. Disarm the launch panel, remove the model, clean the igniter residue from the nozzle, and install a new igniter. Follow the launching procedure again.

SP-70

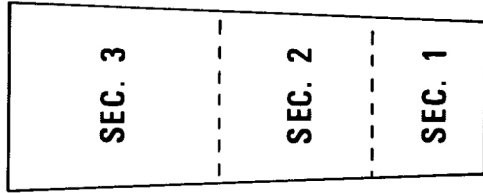
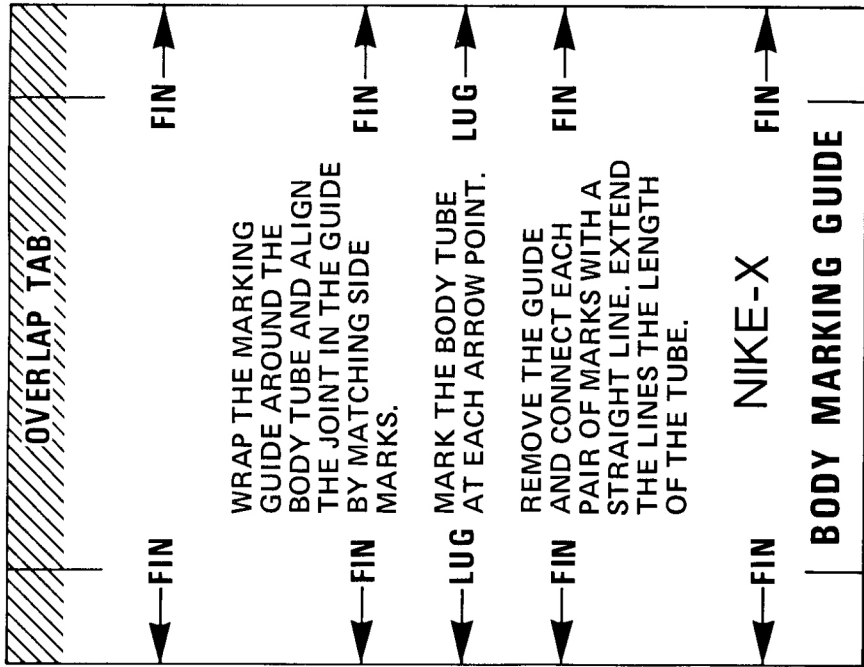

SHOCK CORD MOUNT

HOLD-DOWN STRAP

1 Inch

1 Inch

1 Inch

1 Inch

1 Inch

1 Inch

1 Inch

1 Inch

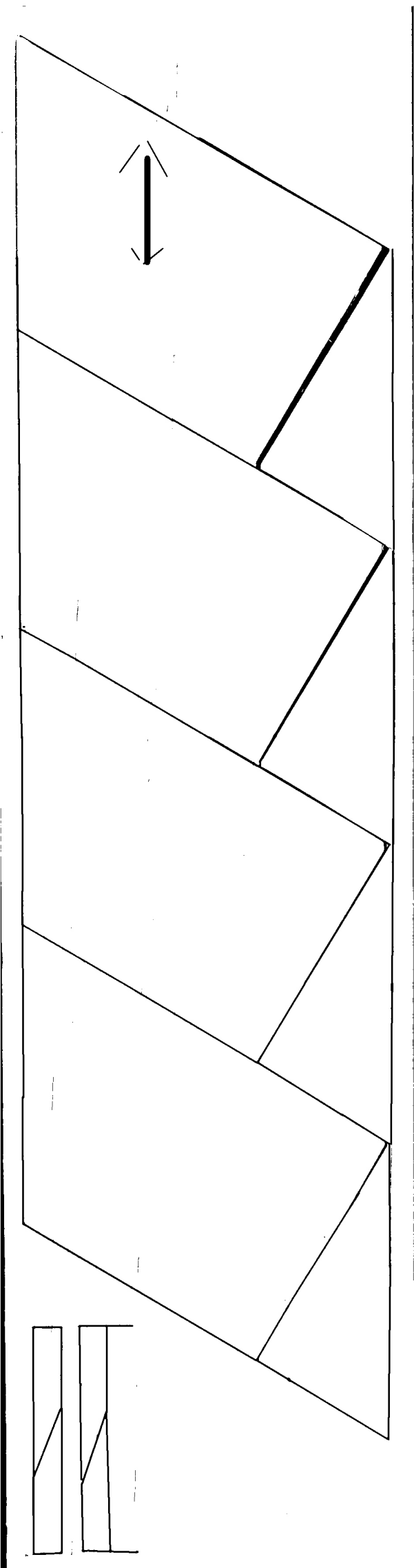

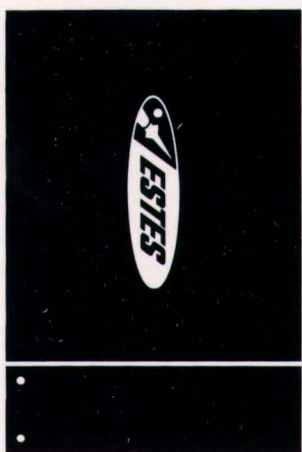
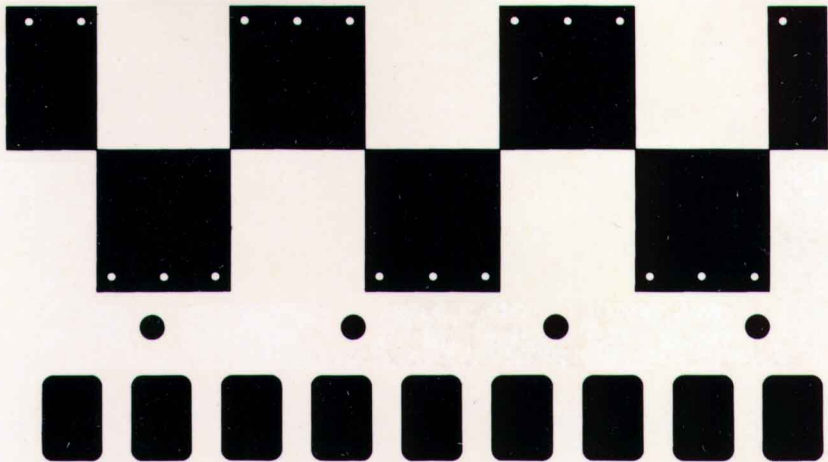

U. S. A R M Y
U. S. A R M Y

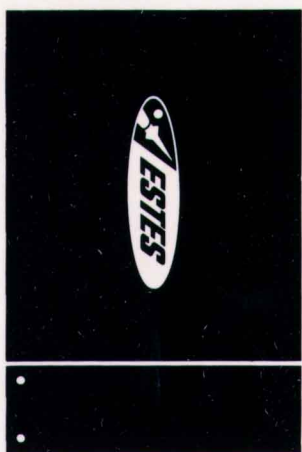

○ ○
TEST CONN.

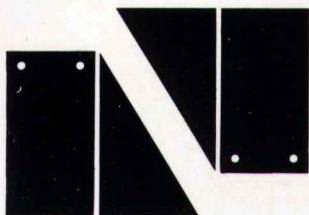

○ ○
TEST CONN.

NIKE-X

PN 37070
ESTES INDUSTRIES

NIKE-X

