





A SUBSIDIARY OF DAMON

RUSSIAN VOSTOK

LAUNCH VEHICLE FOR THE
FIRST MANNED ORBITAL FLIGHT.

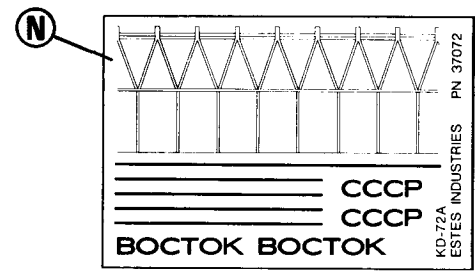
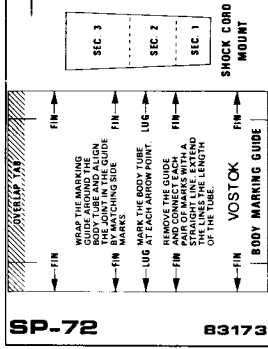
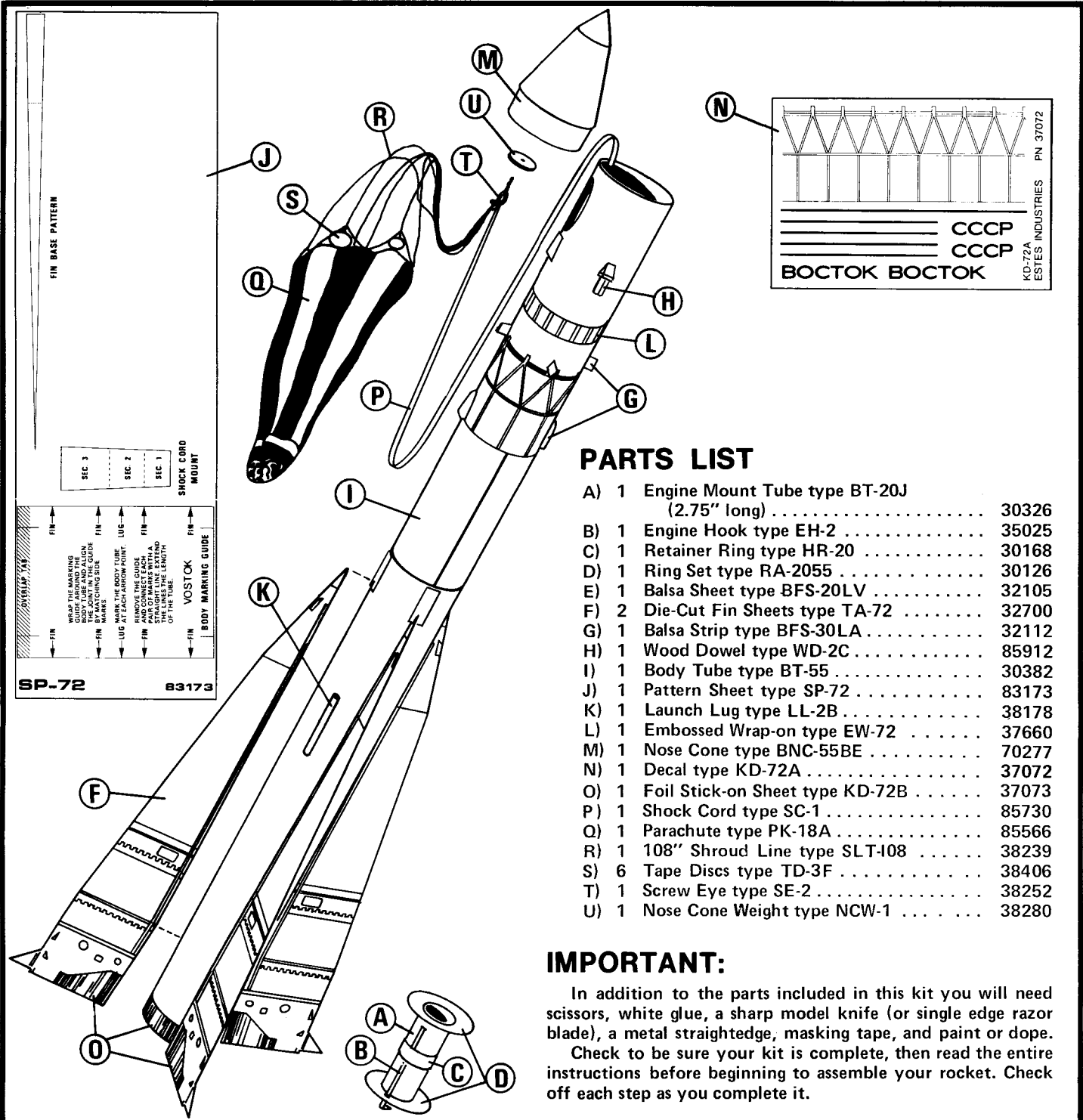

PARTS LIST

A)	1	Engine Mount Tube type BT-20J (2.75" long)	30326
B)	1	Engine Hook type EH-2	35025
C)	1	Retainer Ring type HR-20	30168
D)	1	Ring Set type RA-2055	30126
E)	1	Balsa Sheet type BFS-20LV	32105
F)	2	Die-Cut Fin Sheets type TA-72	32700
G)	1	Balsa Strip type BFS-30LA	32112
H)	1	Wood Dowel type WD-2C	85912
I)	1	Body Tube type BT-55	30382
J)	1	Pattern Sheet type SP-72	83173
K)	1	Launch Lug type LL-2B	38178
L)	1	Embossed Wrap-on type EW-72	37660
M)	1	Nose Cone type BNC-55BE	70277
N)	1	Decal type KD-72A	37072
O)	1	Foil Stick-on Sheet type KD-72B	37073
P)	1	Shock Cord type SC-1	85730
Q)	1	Parachute type PK-18A	85566
R)	1	108" Shroud Line type SLT-108	38239
S)	6	Tape Discs type TD-3F	38406
T)	1	Screw Eye type SE-2	38252
U)	1	Nose Cone Weight type NCW-1	38280

IMPORTANT:

In addition to the parts included in this kit you will need scissors, white glue, a sharp model knife (or single edge razor blade), a metal straightedge, masking tape, and paint or dope. Check to be sure your kit is complete, then read the entire instructions before beginning to assemble your rocket. Check off each step as you complete it.

ASSEMBLY INSTRUCTIONS

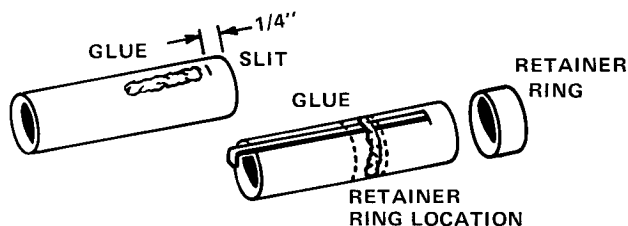

1 Cut a 1/8" long slit in the engine mount tube (part A), 1/4" from one end as shown. Apply a 1" long line of glue to the tube as shown. Push one end of the engine hook (part B) into the slit and press the main part of the hook into the glue. Apply a line of glue around the middle of the tube and slide the retainer ring (part C) over tube and hook onto the glue.

CUT 1/8" NOTCH IN ONE ADAPTER RING

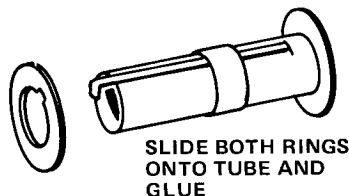

2 Cut a 1/8" square notch in the inside edge of one adapter ring (part D). Slide the notched ring onto the end of the engine mount tube from which the hook projects. Slide the other ring onto the opposite end of the tube. Apply a line of glue at the ring/tube joint on both sides of each ring. Let this assembly dry.

POSITION PATTERNS AS SHOWN

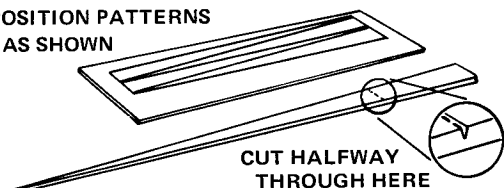

BEND TO THIS ANGLE

3 Using the fin base pattern on the pattern sheet (part J), mark four fin base pieces on the balsa sheet (part E). Cut out the fin bases using a very sharp knife with a metal straightedge for a guide. Cut notch halfway through the balsa at the dotted line on the pattern and bend the base slightly at this point.

DO NOT GET GLUE ON ANY PART OF FIN OTHER THAN ALONG EDGE

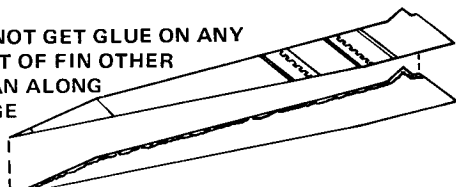

4 Separate a matching pair of fin halves from the die-cut sheet (part F). Apply a line of glue to the inner face of one half just along the outside edge. Do not get glue on any other parts of the fin. Press the matching fin halves together with their edges even and set aside to dry. Repeat with the other three fin sets.

MAKE TWO FORWARD PIECES

TOP VIEW

1/8" 3/32"

SIDE VIEW

1/16" 1/4"

GLUE 5/16" LONG DOWELS TOGETHER AND TO FORWARD PIECES



5 Make two separation piston assemblies. Cut and sand to the shape shown two forward pieces using the balsa strip (part G). Cut four 5/16" long pieces from the dowel (part H)

and sand their ends until all four are the exact same length. Glue all parts together to form the complete assemblies shown. Set on plastic or waxed paper while the glue dries.

INSERT ENGINE MOUNT SO HOOK END IS EVEN WITH OUTER TUBE END

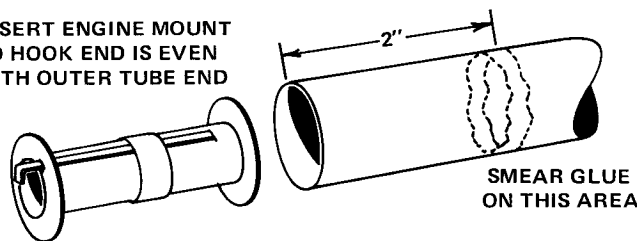

6 Apply a line of glue around the inside of the body tube (part I), 2" from one end. Insert the engine mount assembly, unnotched ring first, until the projecting end of the engine hook is even with the end of the body tube. Apply a line of glue to the joint between the rear ring and the body. Set the tube on its forward end while the glue dries.

MARK BODY AT EACH ARROW POINT

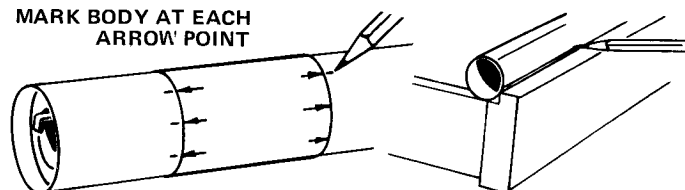

USE EDGE OF DRAWER OR DOOR FRAME AS A GUIDE

7 Cut out the tube marking guide from the pattern sheet. Wrap the guide around the body tube and mark the body at each arrow point. Draw straight lines the length of the tube through each fin mark. Draw a straight line 9" forward from the rear of the body at the launch lug mark. Use the edge of a drawer or door frame as a guide to keep the lines straight on the body.

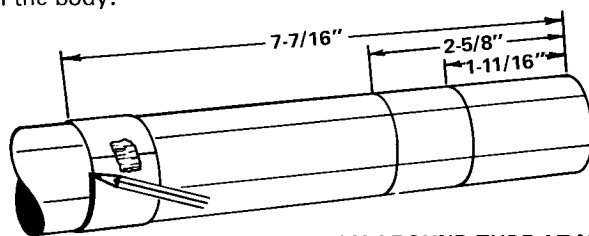

DRAW LINE COMPLETELY AROUND TUBE AT MARKS

8 Mark one of the fin lines at points 1-11/16", 2-5/8" and 7-7/16" from the front of the body tube. Wrap the tube marking guide around the body with its edge even with one mark and draw a line completely around the tube at this point. Repeat for the other two marks.

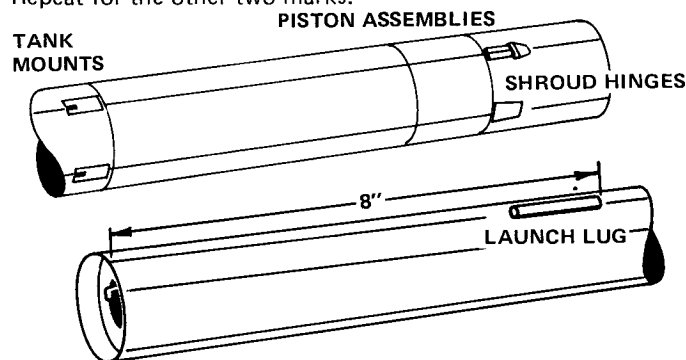

9 Glue the piston assemblies and shroud hinges from the die-cut fin sheet to the body with their rear edges on the forward line as shown, each centered on its fin line. Glue the front tank mounts to the body, centered on the fin lines, with their front edges on the rear line. Glue the launch lug (part K) to the launch lug line with its front edge 8" from the rear of the body.

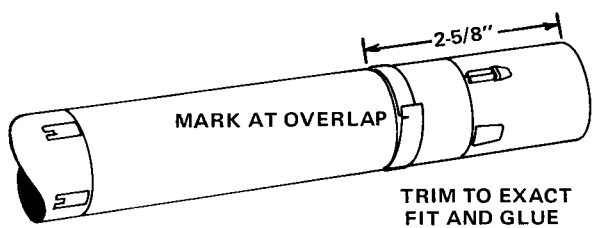

TRIM TO EXACT FIT AND GLUE

10 Wrap the embossed wrap-on (part L) around the body and mark it where it laps over itself. Trim on this mark so the wrap-on fits exactly around the body. Spread a thin layer of glue on the back of the wrap-on and position it on the body with its rear on the second line from the front. Hold it in place until the glue sets.

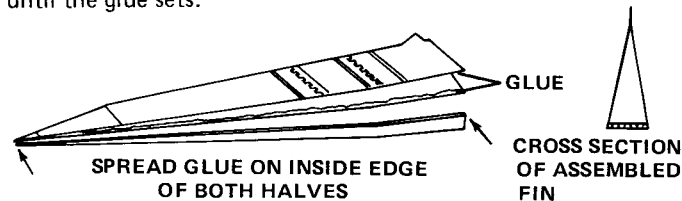

SPREAD GLUE ON INSIDE EDGE OF BOTH HALVES

11 Check the fit of the fin bases inside the root edges of the fins. Sand as necessary for an even fit. Apply a thin line of glue to the inside root edges of a fin and work the base piece into place, starting at the front. With the base lined up even in the fin, set it aside to dry and assemble the other three fins.

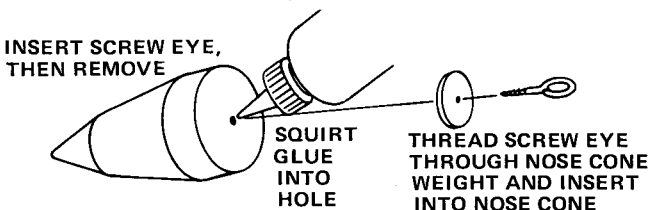

12 Insert the screw eye (part T) into the base of the nose cone (part M). Remove screw eye and squirt glue into the hole. Install the nose cone weight (part U) on the screw eye and reinsert the screw eye into the hole in the nose cone.

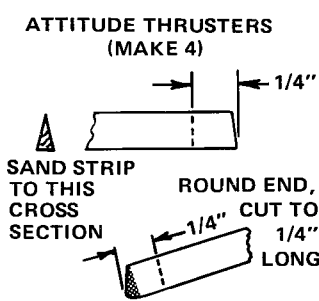
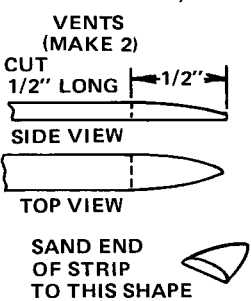

13 Make two vents and four attitude control thrusters from the balsa strip (part G). Make the vents first, sanding the forward shaped portion while still attached to the stick, then cut the formed part off and make another. Sand a 1-1/2" length on one end of the balsa to the triangular shape shown for the attitude thrusters, then round the end and cut 1/4" from the end to make the first thruster. Repeat for the other three.

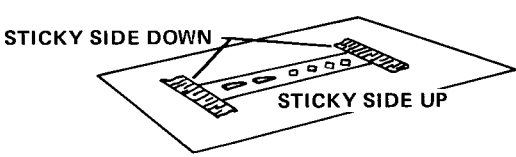

14 Tape a piece of masking tape, sticky side up, on a sheet of cardboard. Stick the root sides of the attitude thrusters and the vents to the masking tape. Apply two or more coats of sanding sealer to all balsa parts (the nose cone, the parts already on the body, and the parts on the masking tape). Sand lightly with extra fine sandpaper between coats. Repeat until pores are filled and surfaces look and feel smooth.

15 Apply a light, even coat of white paint to the body, the nose cone, and the parts on the masking tape. Let dry completely, then follow with another coat until a good, complete, white paint finish is achieved. Let these parts dry completely.

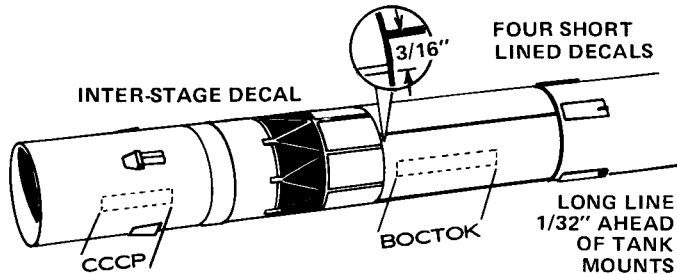

16 When the paint is dry, apply decals (part N). Start with the long, thin line. Cut it out, dip it in lukewarm water for 10 seconds, and hold it until it uncurls. Slip the decal off the backing sheet and onto the body, wrapping it around the body 1/32" ahead of the tank mounts. Blot excess water away. Apply the four shorter lines straight forward from the first decal as shown. Apply the inter-stage decal so its rear is even with the front of the four lines. Finally, apply the red letter decals on opposite sides of the body in the positions shown.

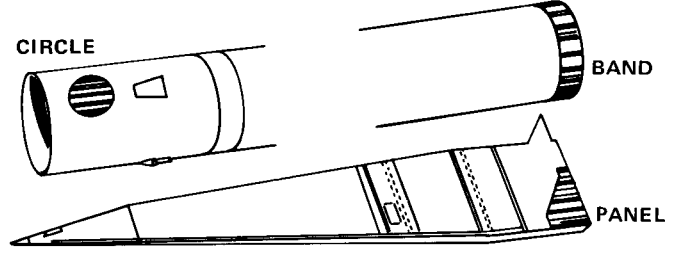

17 Apply the foil stick-ons (part O). Wrap the long band around the rear of the body so its seam is at a fin line. Apply the eight panels to the fins and the hatch circle to the body centered between a hinge and the front of the body.

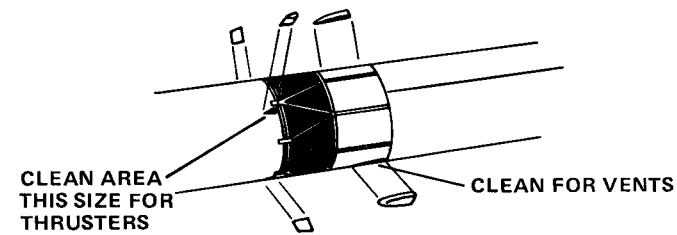

18 When the decals have dried completely, apply a coat of clear spray to protect them. Mark the locations of the attitude thrusters and the vents as shown. With a sharp knife blade, carefully scrape through the decal and the paint to the body at these locations. Glue the thrusters and vents to the body.

19 If the fin lines drawn in step 7 do not show through the paint, draw a light pencil line straight back from the center of each tank mount. Use a guide to make sure the lines run perfectly straight on the body. Mark each line 2" from the rear of the body.

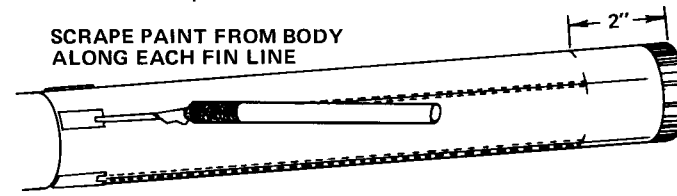

20 Scrape a 1/16" wide strip of paint from the body along each line, starting at the rear of the tank mounts and continuing to the marks made in the last step.

COUNTDOWN CHECKLIST

- 14** Pack eight to ten squares of crumpled recovery wadding loosely into body tube.

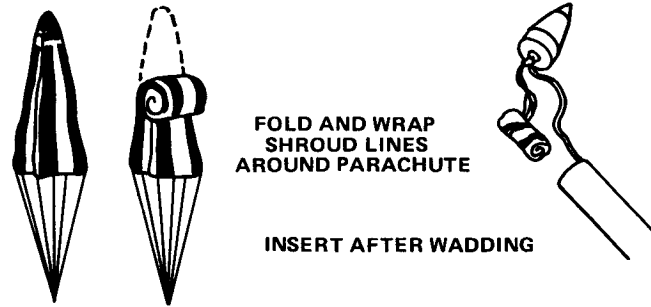

- 13** Fold the parachute into a triangular shape. Roll 'chute tightly as shown and wrap shroud lines around it. If 'chute is too large, unroll and repack until it slides easily into rocket. A very tight fit may prevent parachute from ejecting properly.

NOTE: DO NOT pack parachute until you are actually ready to launch. For maximum parachute reliability, lightly dust the 'chute with ordinary talcum powder before each flight, especially in cold weather.

- 12** Pack shock cord neatly into rocket.

Slide nose cone into place. Nose cone should separate easily from rocket body tube, but should not be extremely loose. If it is too tight, sand inside of body tube end and shoulder of nose cone with extra fine sandpaper.

If nose cone is too loose, add a wrapping of transparent tape or masking tape to the shoulder of the nose cone.

- 11** Select an engine and install an igniter as directed in the engine instructions. Engines recommended for use with this rocket are A8-3, B6-4, B14-5 and C6-5.

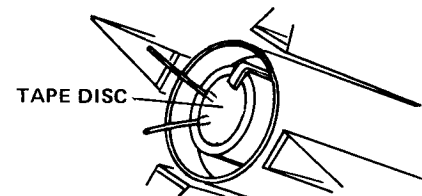

- 10** Insert engine into rocket. Engine hook must latch securely over end of engine.

- 9** Disarm the launch panel--remove safety key.

- 8** Place rocket on launch pad making sure rocket slides freely on launch rod. Clean the micro-clips and attach them to the igniter.

- 7** Clear the launch area, alert recovery crew and trackers. Check for low flying aircraft and unauthorized persons in the recovery area.

- 6** Arm the launch panel--insert safety key.

5 - 4 - 3 - 2 - 1 LAUNCH !!

MISFIRE PROCEDURE

Occasionally the igniter will heat and burn in two without igniting the engine. This is almost always caused by a failure to install it correctly. Disarm the launch panel, remove the model, clean the igniter residue from the nozzle and install a new igniter. Follow the launching procedure again.

ESTES INDUSTRIES, PENROSE, COLO. 81240

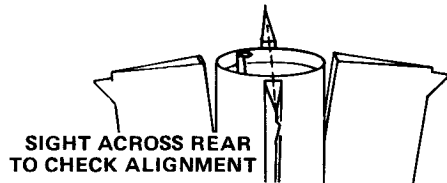
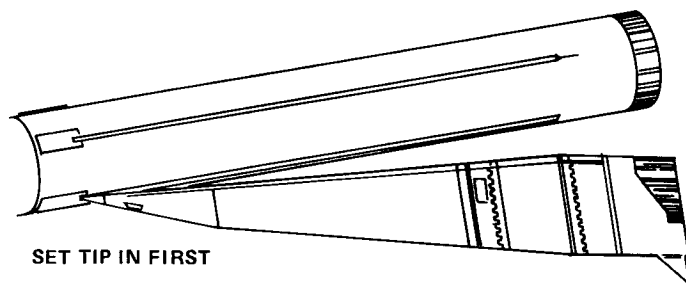

- 21** Apply a line of glue along the center of a fin base from the front to the bend. Stick the front of the fin into the slot in the tank mount and press the base of the fin to the body, making sure fin is centered on the fin line. Attach the other fins in the same manner. Set the model on its nose while the glue dries. While the glue is drying, sight across the rear of the body to make sure the fins are pointing straight out from the body. Make any necessary adjustments immediately.



- 22** Cut out the shock cord mount from pattern sheet. Pre-fold it on the dotted lines. Apply glue to section 1 and lay the shock cord (part P) into the glue. Fold over and apply glue to the back of the first section and the exposed part of section 2. Lay the shock cord as shown and fold over again. Clamp the unit together with your fingers until the glue sets.

SPREAD GLUE INSIDE BODY TUBE, PRESS MOUNT ONTO GLUE

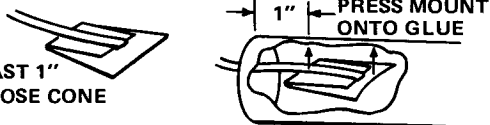

- 23** Apply glue to the inside of the body at the front over an area about 1" to 2" from the end. The glued area should be the same size as the shock cord mount. Press the mount into the glue as shown and hold it until the glue sets.

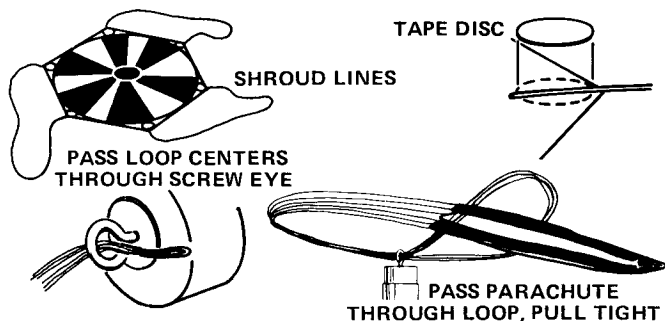

- 24** Cut out the parachute (part Q) on its edge lines. Cut three 36" lengths of shroud line (part R). Attach line ends to top of parachute with tape discs (part S) as shown. Pass shroud line loops through screw eye. Pass parachute through loop ends and draw lines tight against screw eye. Set knot with a drop of glue. Tie free end of shock cord to screw eye.

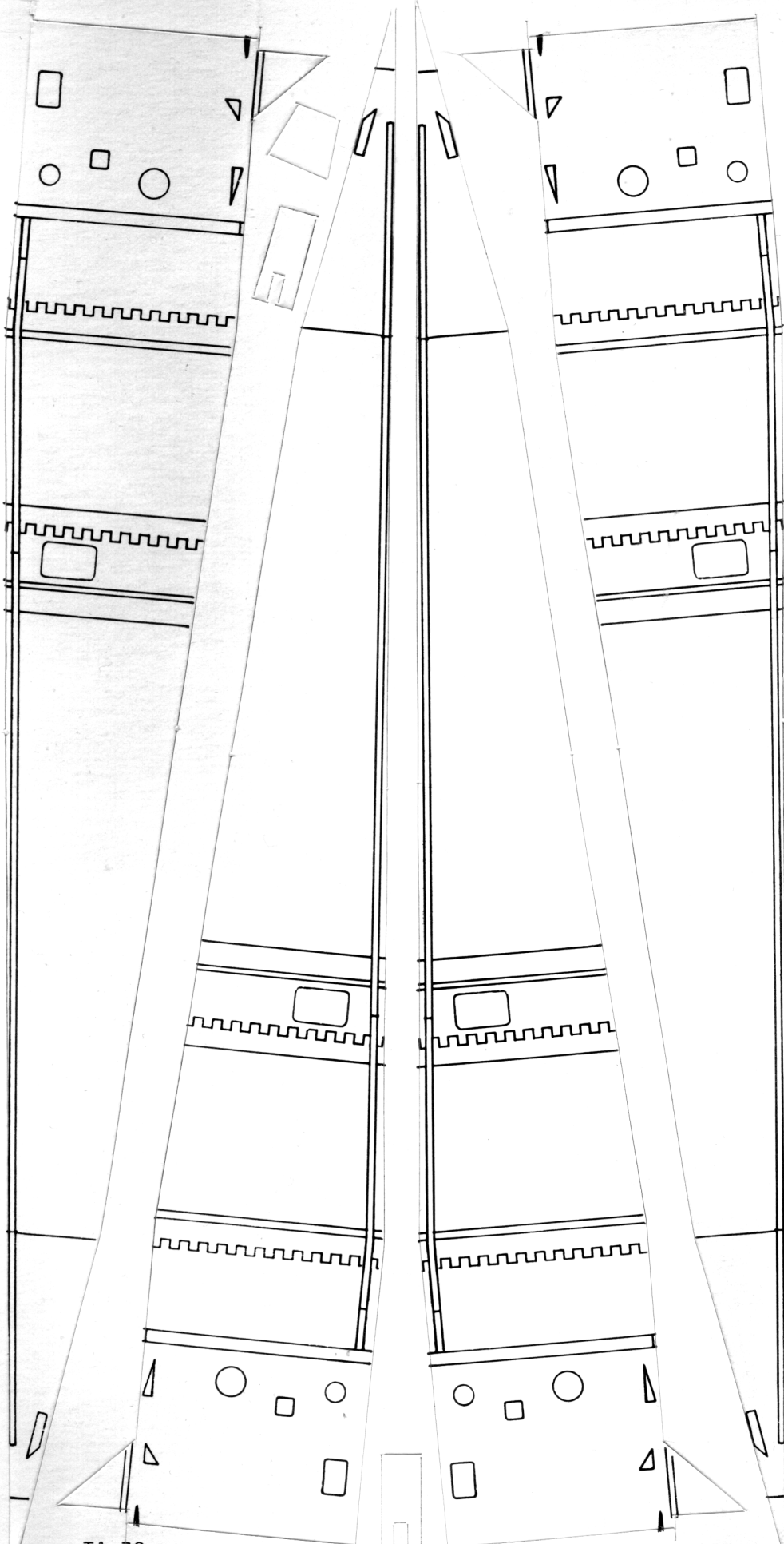

TA-72

PN 32700

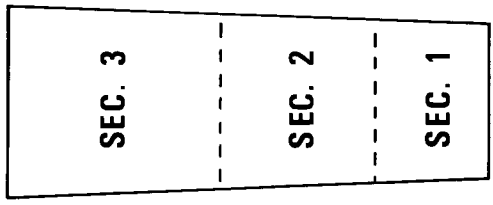
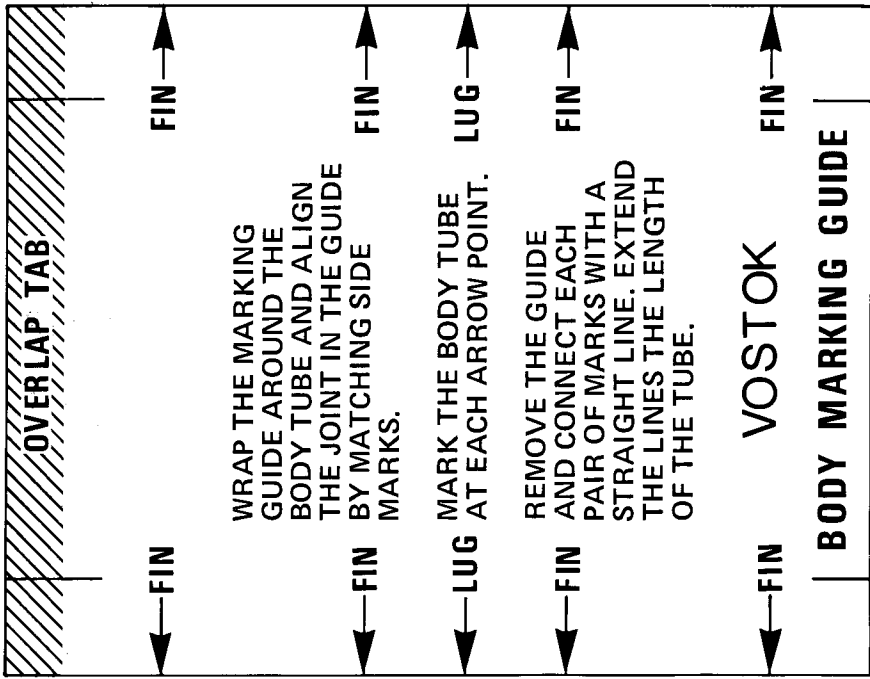

SHOCK CORD MOUNT

FIN BASE PATTERN

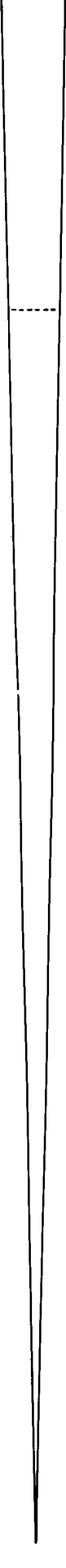



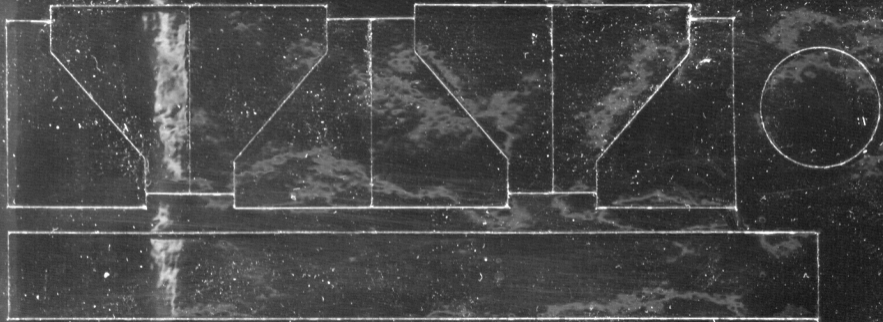

ВОСТОК ВОСТОК

**СССР
СССР**

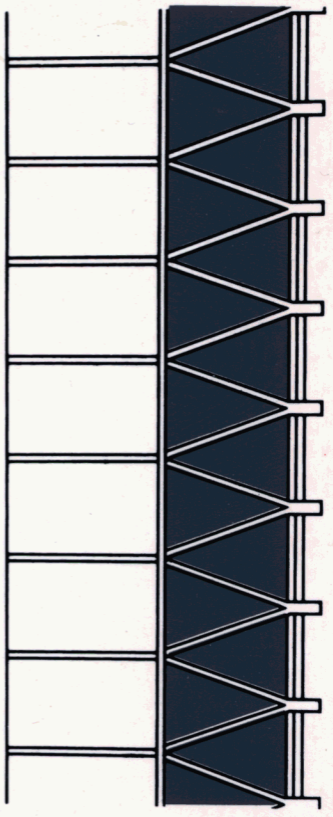

KD-72A

ESTES INDUSTRIES

PN 37072

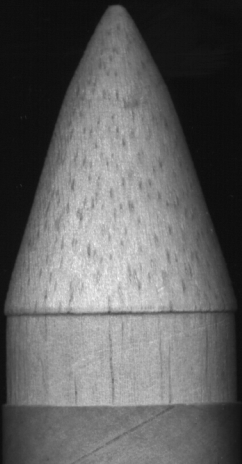

4 8 12 16 20 24 28

32

1

4 8 12 16 20 24 28

2

4 8 12

95 87 07 26 42 91 8

21

95 87 07 26 42 91 8

91

95 87 07



RUSSIAN MISSION BOSTON



- RUSSIAN SPACE VEHICLE
- PREPARING FOR LAUNCH
- LAUNCHING SOYUZ ROCKET
- SAFE LANDING FLIGHT
- RETURNING SPACE VEHICLE

Name _____
 Address _____
 City _____ State _____ Zip _____
 Phone _____
 E-mail _____
 Date _____