

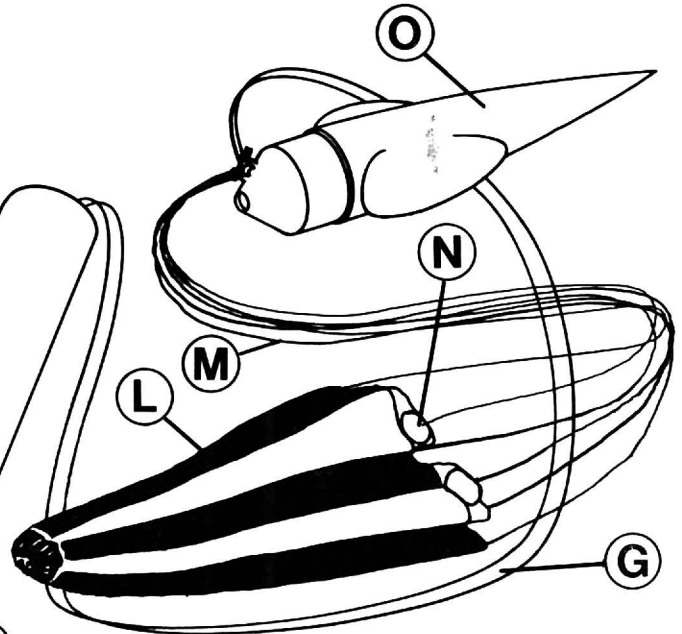

Alien INVADER

KIT NO. 1281

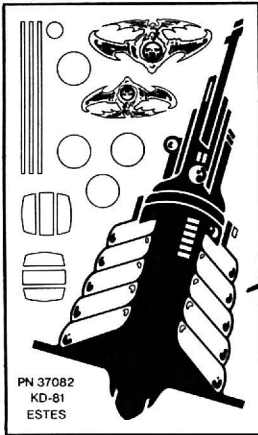
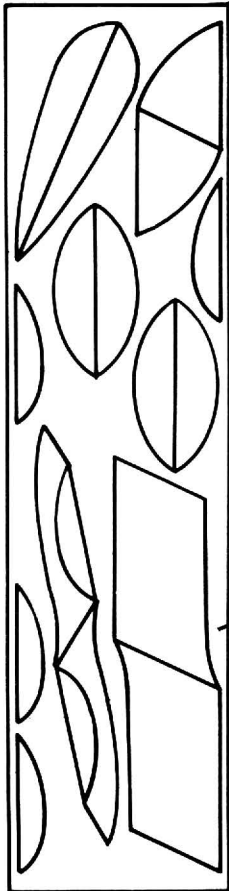

PARTS LIST

		PART NO.
A)	1	Balsa Fin Sheet (type BF-81)..... 32293
B)	1	Pattern Sheet (type SP-81)..... 83203
C)	1	Engine Mount Tube (type BT-20J) 30326
D)	1	Engine Hook (type EH-2) 35025
E)	1	Split Adapter Ring (type AR-2050S)... 80425
F)	1	Adapter Ring (type AR-2050) 30164
G)	1	Shock Cord (type SC-1)..... 85730
H)	1	Body Tube (type BT-50L)..... 30366
I)	2	Ram Body Tubes (type BT-50J)..... 30362
J)	2	Launch Lugs (type LL-2A)..... 38175
K)	1	Wood Dowel (type WD-1S)..... 85904
L)	1	Parachute (type PK-12A) 85564
M)	1	72" Shroud Line Cord (type SLT-72) .. 38237
N)	6	Tape Discs (type TD-3F) 38406
O)	1	Nose Cone (type PNC-50CA)..... 71005
P)	1	Decal (type KD-81) 37082

In addition to the parts included in this kit you will need scissors, white glue, a sharp model knife (or single edge razor blade), sandpaper, sanding sealer, and paint.

IMPORTANT:

Read all instructions before beginning work on your model. Make sure you have all parts and materials. When you are thoroughly familiar with the assembly procedure, begin construction. Check off each step as you complete it. In each step, test-fit the parts together before applying any glue. If some part doesn't fit properly, sand lightly or build up as appropriate for precision assembly.



A SUBSIDIARY OF DAMON

ESTES INDUSTRIES
PENROSE, COLO. 81240

ASSEMBLY INSTRUCTIONS

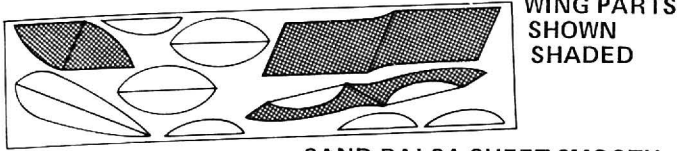

SAND BALSA SHEET SMOOTH AND REMOVE WING PARTS

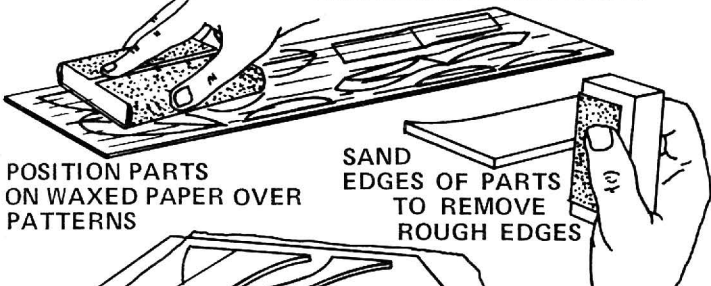

LINE UP ROOT EDGES USING EDGE OF RULER AND WEIGHT PARTS DOWN

1 Fine sand the balsa sheet (part A), then carefully remove the wing panels, using a sharp knife or single edge razor blade to free the edges. Sand the edges of the wing panels slightly to remove any rough edges—but be careful to leave the edges square and sharp-cornered. Cut the wing assembly patterns from the pattern sheet (part B) on the dotted line. Cover the wing assembly patterns with waxed paper. Glue the wing panels together, positioning them on the waxed paper over the patterns. Use a straight edge to be sure all root edges are straight. Weight down the parts to hold them in place while the glue dries.

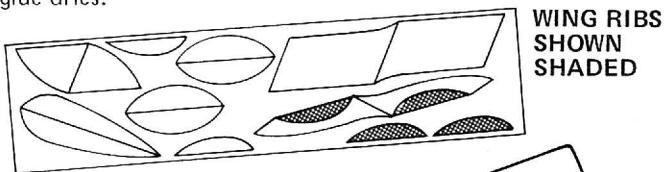

POSITION FRONT EDGE OF RIB 1/16" FROM FRONT OF WING



2 Carefully remove the wing ribs from the balsa sheets. Sand their edges smooth, then apply glue and position them on the wings in the positions shown in the assembly patterns. The front of each rib should be 1/16" from the front of the wing. Be careful to not disturb the wing panels.

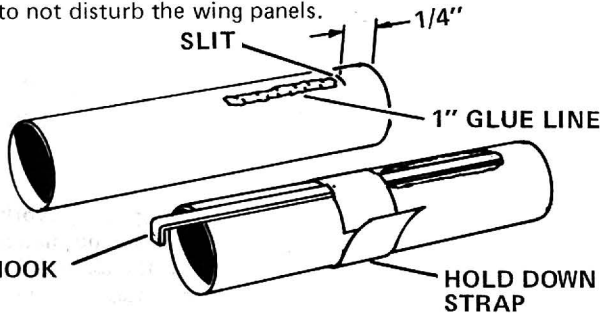

3 Mark the engine mount tube (part C) 1/4" from one end. Cut a 1/8" long slit in the tube at the mark as shown. Cut out the hold-down strap from the pattern sheet. Apply a 1" long line of glue to the tube as shown. Push one end of the engine hook (part D) into the slit and press the main part of the hook into the glue. Apply glue to one side of the hold-down strap and wrap it tightly around the middle of the tube over the engine hook.

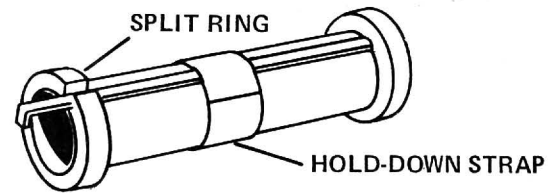

HOOK MUST BE FREE TO RAISE IN SLOT

4 Glue the split adapter ring (part E) to the engine mount tube even with the rear end (the end with the overhanging hook) so the slot is over the hook. Avoid getting glue in the slot. Glue the other ring (part F) to the front of the engine mount against the end of the hook as shown.

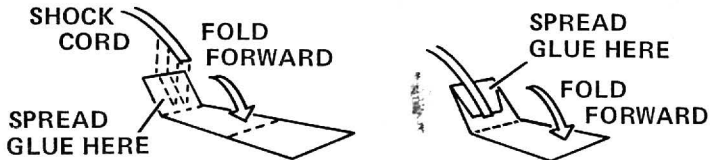

5 Cut out the shock cord mount from the pattern sheet. Crease it on the dotted lines by folding. Spread glue on the first section (1) and lay the end of the shock cord (part G) into the glue. Fold over and apply glue to the back of the first section and the exposed part of section 2. Clamp the unit together with your fingers until the glue sets.

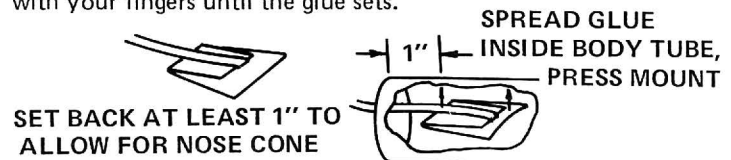

6 Apply glue to the inside of the body tube (part H) at one end over an area about 1" to 2" from the end. The glued area should be the same size as the shock cord mount. Press the mount into the glue as shown and hold it until the glue sets.

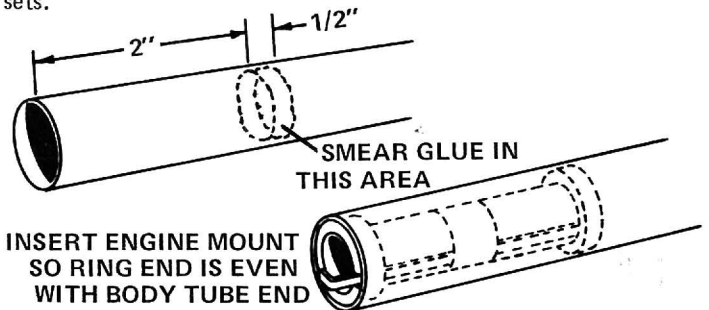

7 Install the engine mount assembly in the end of the body tube opposite the shock cord mount. Smear glue around the inside of the body tube to cover an area about 2" to 2-1/2" from the end of the tube. Immediately insert the engine mount unit, being careful to position it so the engine hook will stick out of the end of the tube. Push the engine mount in with one smooth motion until the ends of the tubes (and the split ring) are even.

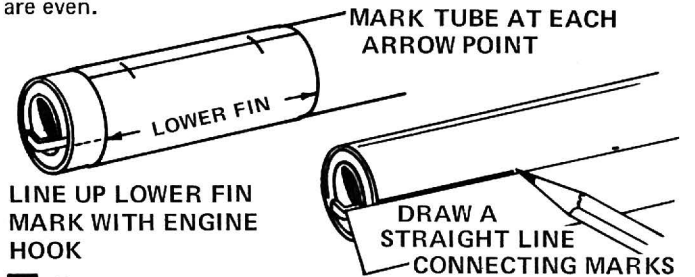

8 Cut out the body tube marking guide from the pattern sheet. Wrap it around the rear of the body so the lower fin mark is in line with the engine hook. Mark the tube at each arrow point, front and rear. Draw a straight line connecting each matching front and rear mark (use a ruler when drawing lines). Extend the wing lines forward 7". Extend the launch lug lines forward 5".

POSITION TOP OF WING
EVEN WITH WING
LINE ON BODY



9 When the wing assemblies have dried, glue them to the body next to the alignment lines as shown. To glue, apply a line of glue to the root edge of a wing half and rub it into the wood. Allow several moments for the glue to set. Apply another line of glue and position the wing on the tube. Refer to the illustration to be sure you position the wing correctly. The rear of the wing must be even with the rear of the body.

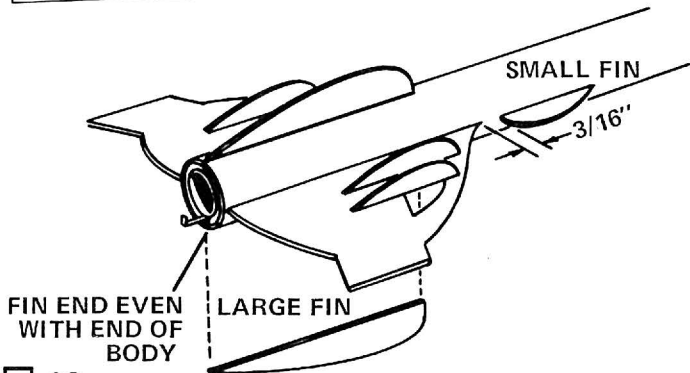
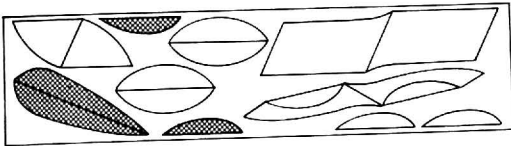

10 Carefully remove the body fins from the balsa sheet and sand their edges smooth. Glue the two large fins to the body, centered on the alignment lines, so their smaller ends are even with the rear of the body. Glue the two small fins to the body, exactly in line with the wings, 3/16" ahead of the wings. The small end of these fins should point forward.

MARK TUBE AT EACH
ARROW POINT

DRAW STRAIGHT LINES
THROUGH MARKS

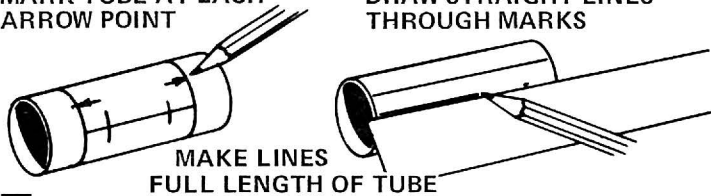

11 Cut out the ram tube marking guide from the pattern sheet. Wrap it around the middle of a ram tube (part I), and mark the tube at each arrow point, front and rear. Draw a straight line connecting each matching front and rear mark (use a ruler). Repeat for the other tube.

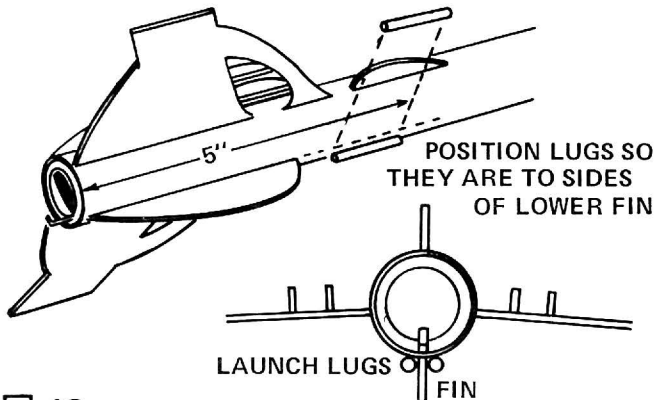

12 Glue the launch lugs (part J) to the body. The front of each lug should be 5" from the rear of the body tube. Position the lugs so they are to each side of the bottom fin as shown.

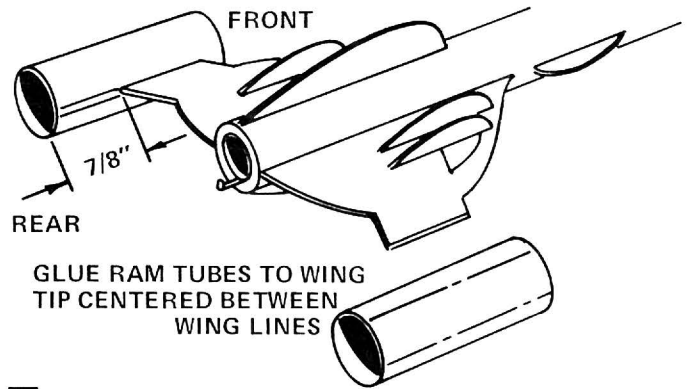

13 Mark the wing tip lines on each ram tube 7/8" from one end. Glue the ram tubes to the wing tips, centered between the wing lines, so the rear of each tube is 7/8" from the rear of the wing tip.

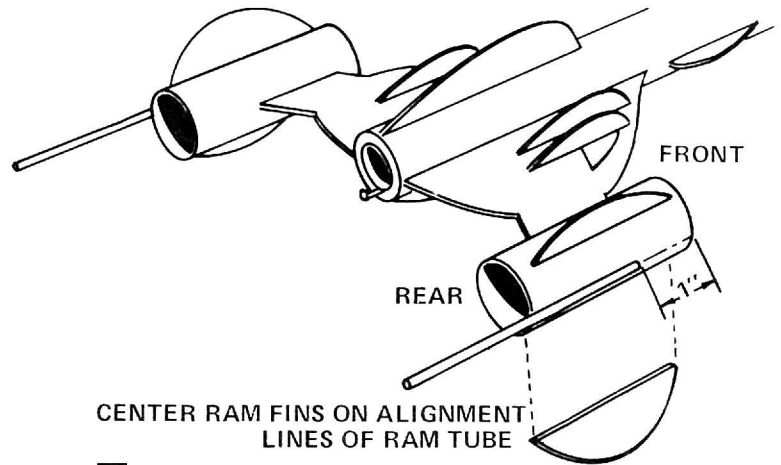

14 Carefully remove the ram tube fins from the balsa sheet. Glue the ram fins to the ram tubes on the alignment lines, positioning them so they are centered on the tube. Cut the dowel (part K) into two pieces, each 3-3/4" long. Glue the dowels to the ram tubes on the alignment lines so the front of each dowel is 1" from the front of its tube.

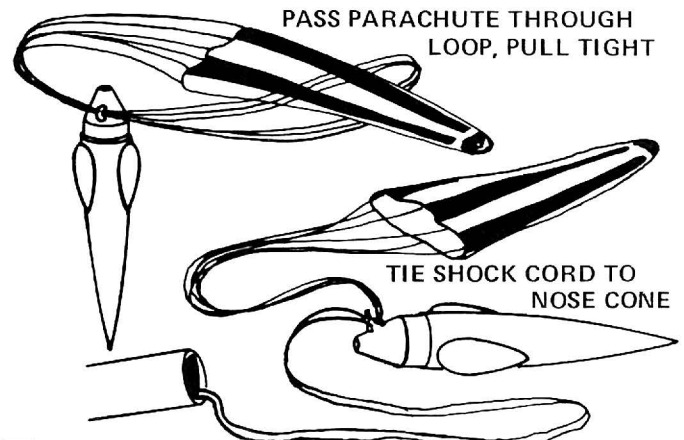
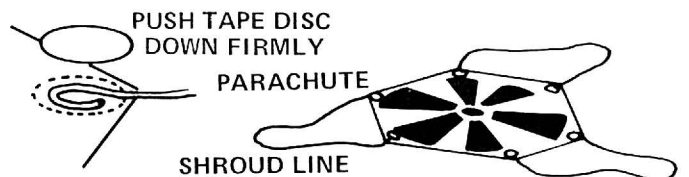

15 Cut out the parachute (part L) on its edge lines. Cut three 24" lengths of shroud line (part M). Attach line ends to the top of the parachute with tape discs (part N) as shown. Pass the shroud line loops through the ring on the nose cone (part O). Pass the parachute through the loop ends and draw the lines tight against the ring. Set the knot with a drop of glue. Tie the free end of the shock cord to the nose cone ring.

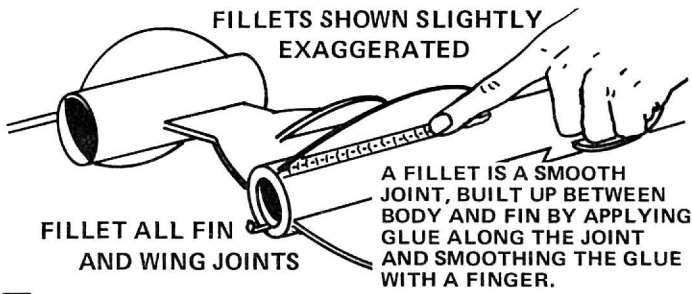

16 Apply a glue fillet to each fin and wing joint. Holding the rocket horizontally (level), apply a line of glue to both sides of each fin joint. Smooth out the glue with your finger. Keep the rocket level until the glue dries.

17 When all glue on the outside of the model is dry, prepare the balsa parts for painting. Apply at least two coats of sanding sealer to the fins and wings. Let dry and sand lightly between coats. Do this until the tiny holes in the wood are filled and everything looks and feels smooth.

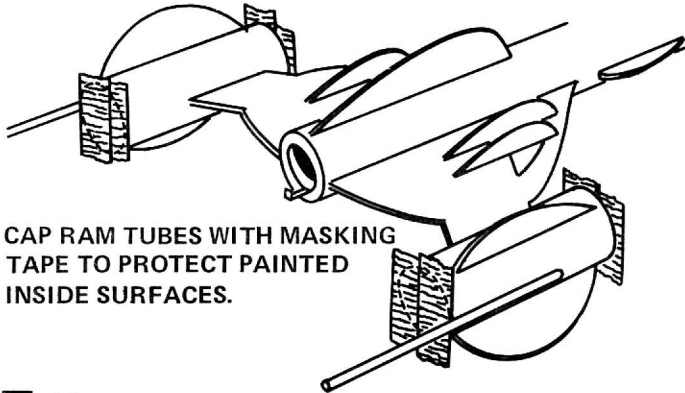

18 Give the entire rocket a spray base coat of white enamel (it may be easier to use brush-on enamel for the insides of the ram tubes only). When the base coat is dry, paint the insides of the ram tubes bright fluorescent orange. Cap the ends of the ram tubes with masking tape. Paint the outside of the rocket using a light color (yellow or orange) for the forward body--from the front fin forward including nose cone. Use black for the remaining rear section of the rocket.

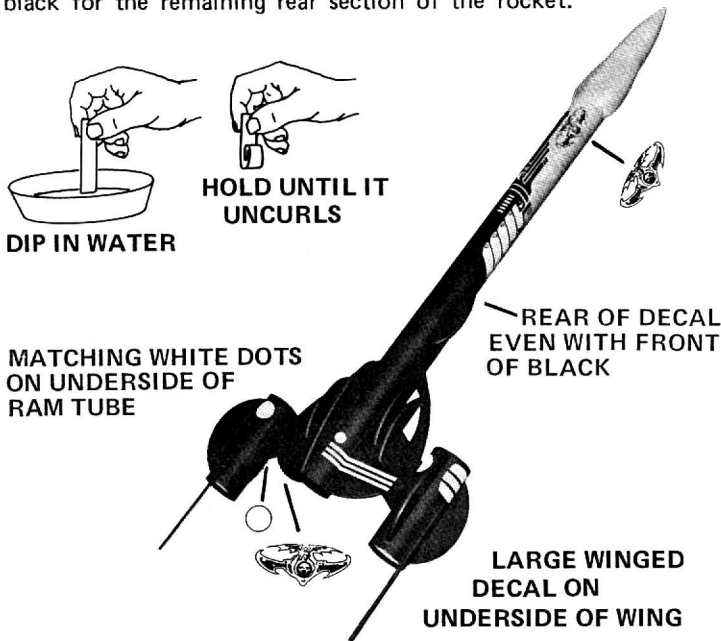

19 When all paint is dry, apply decals (part P) as shown in the photo. Cut out a decal section, dip it in lukewarm water for 10 seconds, and hold it until it uncurls. Slip the decal off the backing sheet and onto the model. Blot excess water away. For best results, let the model dry overnight and apply a coat of clear spray to protect the decals.

COUNTDOWN CHECKLIST

Be sure to follow the HIAA - NAR Model Rocketry Safety Code when carrying out all your model rocketry activities.

T-14 Pack four squares of loosely crumpled recovery wadding into body tube.

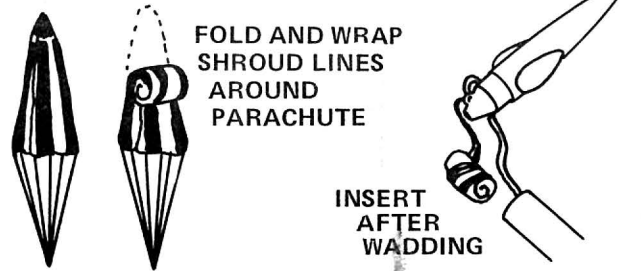

T-13 Fold the parachute into a triangular shape. Roll 'chute tightly as shown and wrap shroud lines around it. If 'chute is too large, unroll it and repack until it slides easily into rocket. A fit that is too tight may prevent parachute from ejecting properly.

NOTE: DO NOT pack parachute until you are actually ready to launch. For maximum parachute reliability, lightly dust the 'chute with ordinary talcum powder before each flight, especially in cold weather.

T-12 Pack shock cord neatly into rocket.

Slide nose cone into place. Nose cone should separate easily from rocket body tube, but should not be extremely loose. If it is too tight, sand inside of body tube end and shoulder of nose cone with extra fine sandpaper.

If nose cone is too loose add a wrapping of transparent tape or masking tape to the shoulder of the nose cone.

T-11 Select an engine and install an igniter as directed in the engine instruction. Engines recommended for use with this rocket are the 1/2A6-2, A8-3, B4-4, B6-4, and C6-5 made by Estes.

Use an A8-3 engine for your first flight.

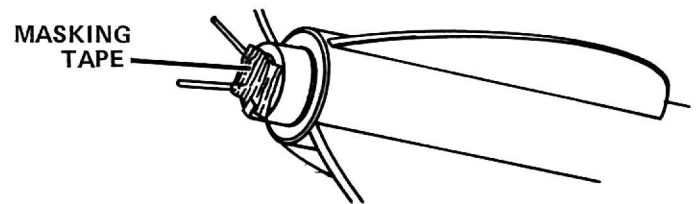

T-10 Insert engine into rocket. Engine hook must latch securely over end of engine.

T-9 Disarm the launch panel--remove safety key.

T-8 Place rocket on launch pad, making sure rocket slides freely on launch rod. Clean the micro-clips and attach them to the igniter.

T-7 Clear the launch area, alert recovery crew and trackers. Check for low flying aircraft and unauthorized persons in the recovery area.

T-6 Arm the launch panel--insert safety key.

5 4 3 2 1 LAUNCH!!

MISFIRE PROCEDURE

Occasionally the igniter will heat and burn in two without igniting the engine. This is almost always caused by a failure to install it correctly. Disarm the launch panel, remove the model, clean the igniter residue from the nozzle, and install a new igniter. Follow the launching procedure again.

3/32"

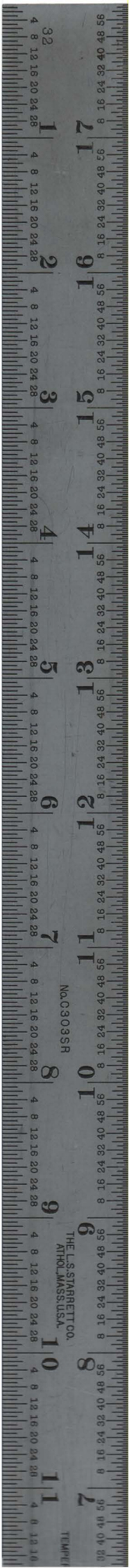
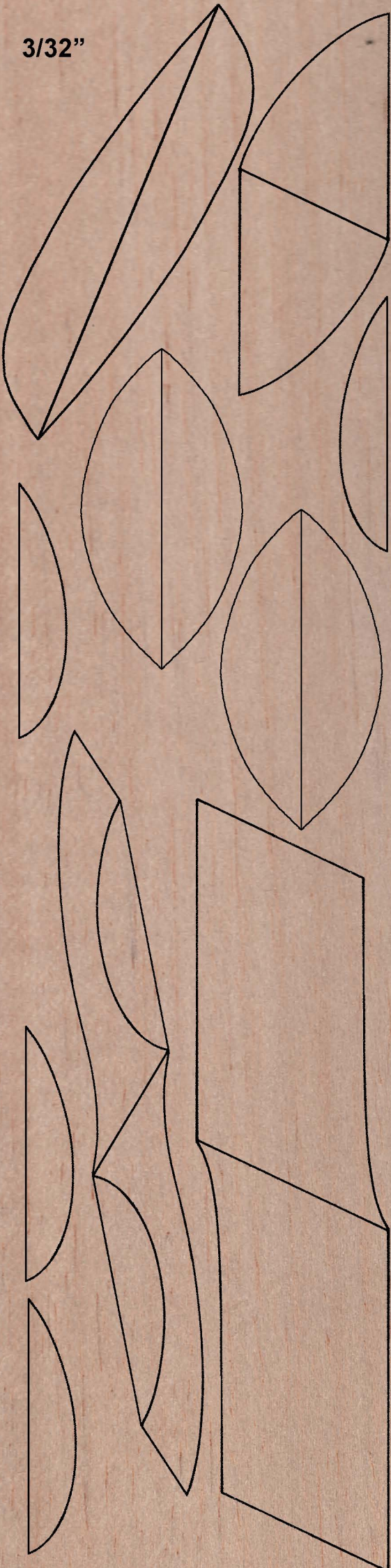

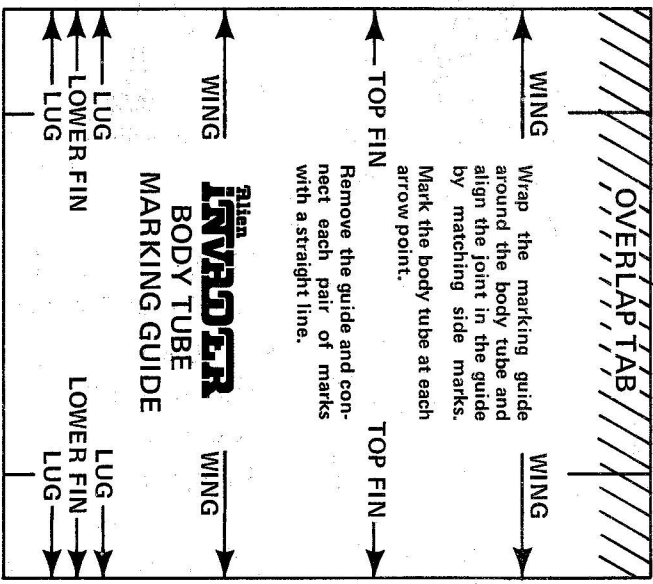
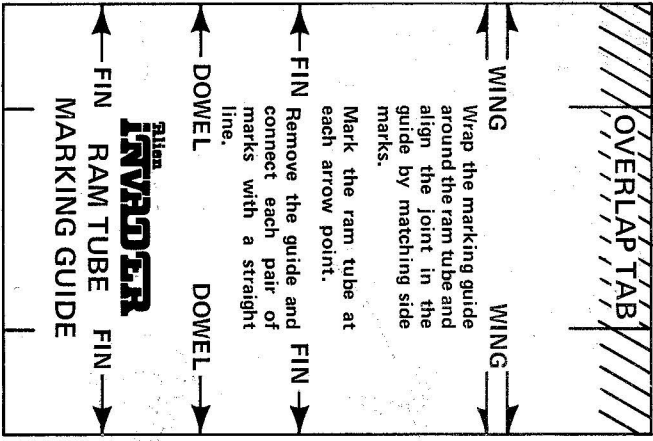
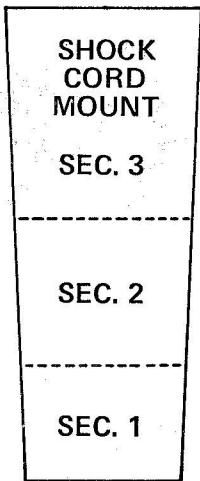

THIS EDGE 4 3/8"

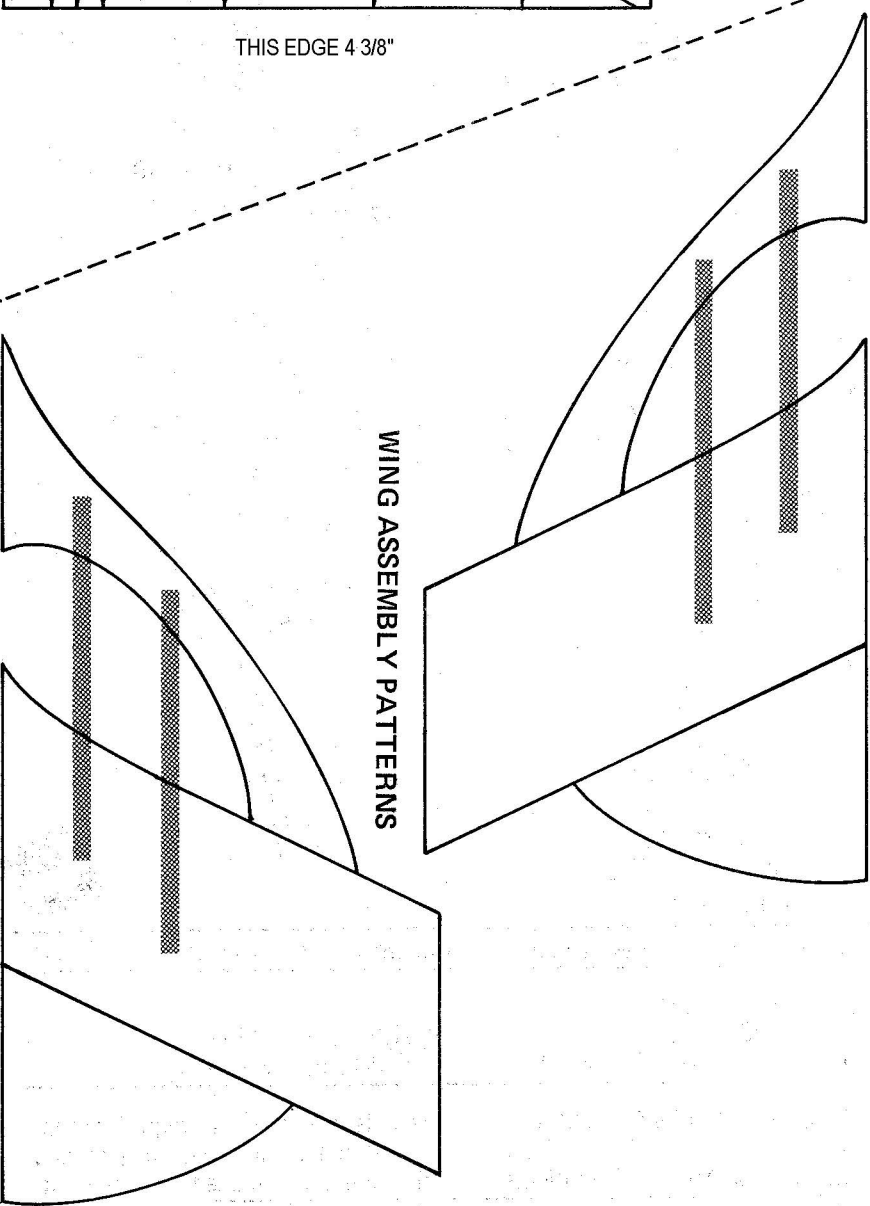

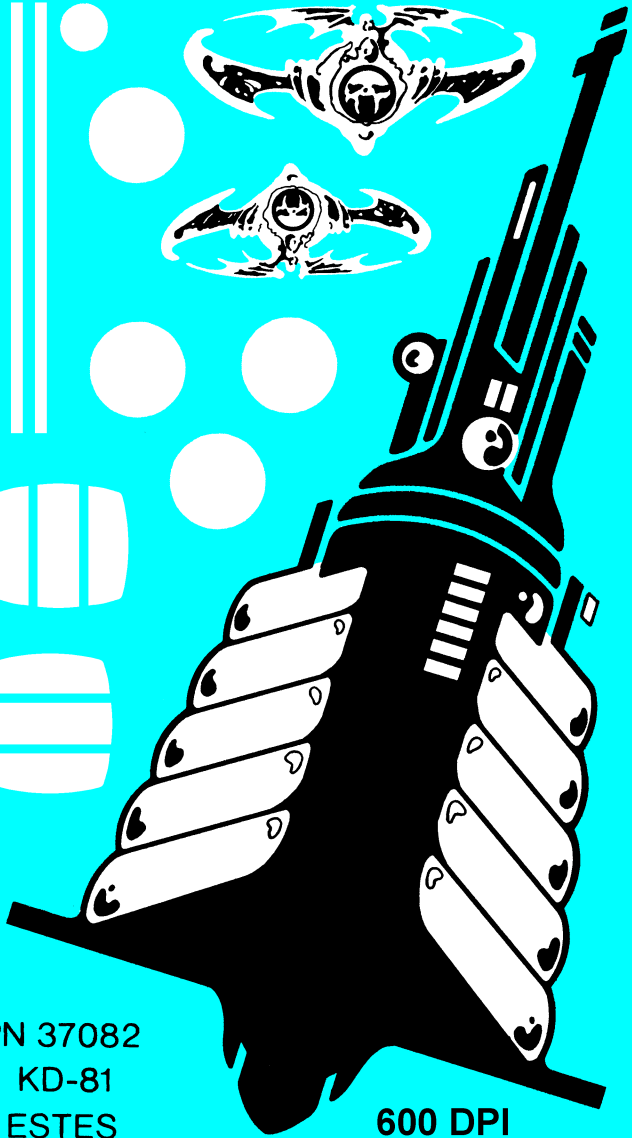
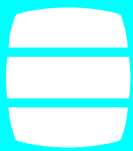
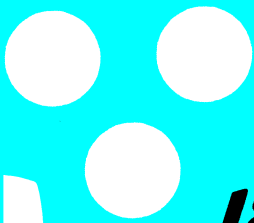

PN 37082
KD-81
ESTES

600 DPI

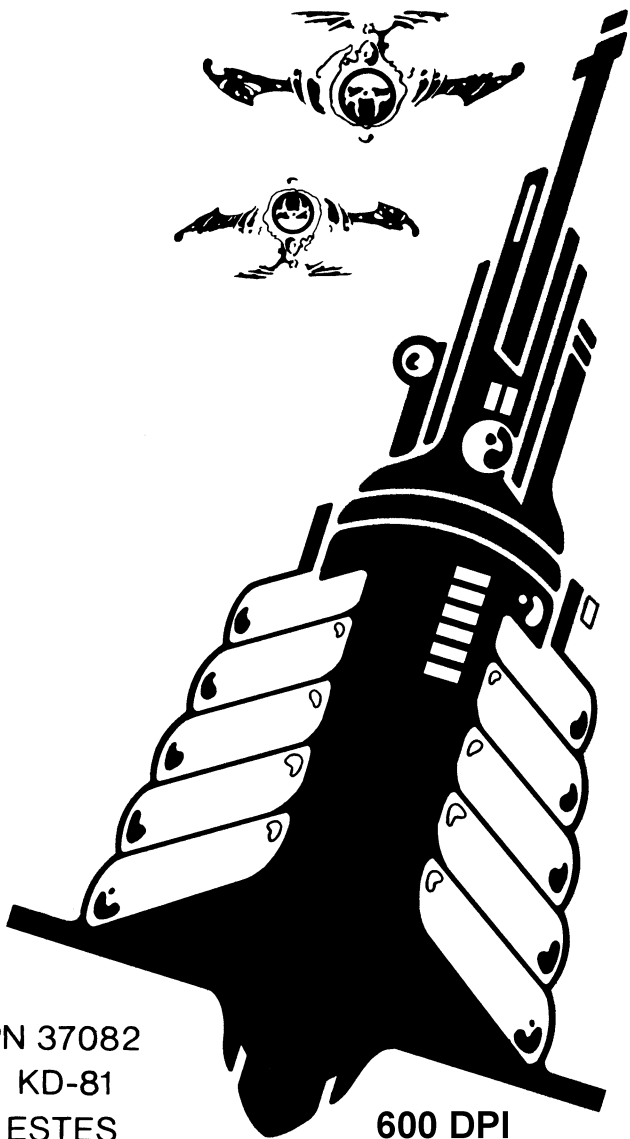

PN 37082
KD-81
ESTES

600 DPI

PARTS LIST KIT NO. 1281 - Alien Invader

Quantity	Description	Type	Number	Details1	Details2	Details3	Details4	Comment
1	BALSA FIN STOCK	BFS-30L	3170	3/32" thick	3" wide	12" long	0.09375	BF-81 - Scan
1	Pattern Sheet	SP-81	83203					Scan
1	PAPER BODY TUBE	BT-20J	30326	2.75" long	0.710" ID	0.736" OD	0.013" wall	
1	ENGINE HOLDER	EH-2	3141/35025	2.8" long	.100" wide	.025" thick		Reg. & D
1	SPLIT ADAPTER RING	AR-2050S	80425				BT-20 in BT-50	
1	CENTERING RING	AR-2050	30164				BT-20 in BT-50	
1	Shock Cord	SC-1	85730	18 " long	1/8" wide			Rubber
1	PAPER BODY TUBE	BT-50L	30366	12.7" long	0.950" ID	0.976" OD	0.013" wall	
2	PAPER BODY TUBE	BT-50J	30362	2.75" long	0.950" ID	0.976" OD	0.013" wall	
2	LAUNCH LUG	LL-2A	2321/38175	5/32" ID	1/8" rod	1-1/4" long		
1	DOWEL	WD-1S	85904	1/8" dia.	7.5" long			Wood
1	Parachute	PK-12A	2263/85564	12" dia.				
1	Shroud Line	SLT-72	38237	72"				
6	Tape Disc	TD-3F	38406	1/2" dia.				6x
1	PLASTIC NOSE CONE	PNC-50CA	71005	4 13/16"	.974" dia.	.750" shoulder	BT-50	
1	Decal	KD-81	37082					Scan

ESTES

Flying Model Rocket



ESTES
 A SUBSIDIARY OF DANCO
Flying Model Rocket

NEW!
BLISS INVERTER



- Plastic Forward Command Hull
- Simulated Engineering Section
- Realistic Atmospheric Propulsion Units
- Mysterious Alien Decor
- Unique Interplanetary Design

MODEL LEVEL 3
 2-Internals 3-Collars 4-Aligners 3-Engines

SPECIFICATIONS:
 Height 20.5" (520mm) Weight 1.02oz (29g)
 Body Dia. 0.976" (24.8mm) 120-Piece Kit Price

RECOMMENDED ENGINES:
 M247 283 644 E63
 E45 Use A8-3 for launch

There is a 20% air freighting surcharge on all international orders and U.S. air mail orders outside the U.S.

ESTES ESTES INDUSTRIES

FLY ESTES
Model Rockets
 Recreating Hobby for Ages 10 to Adult

ESTES INDUSTRIES



