

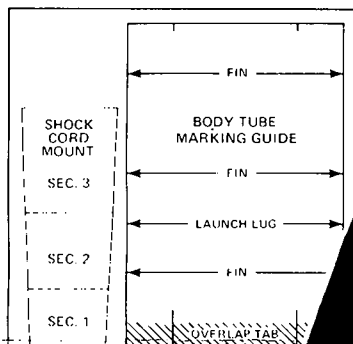

SCAMP

KIT NO. 1286



SP-86 ESTES INDUSTRIES
PN83222

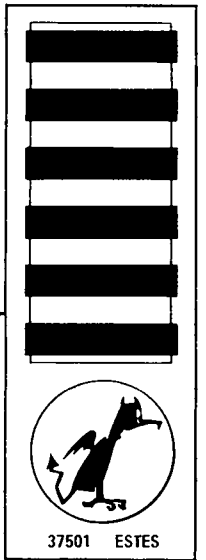
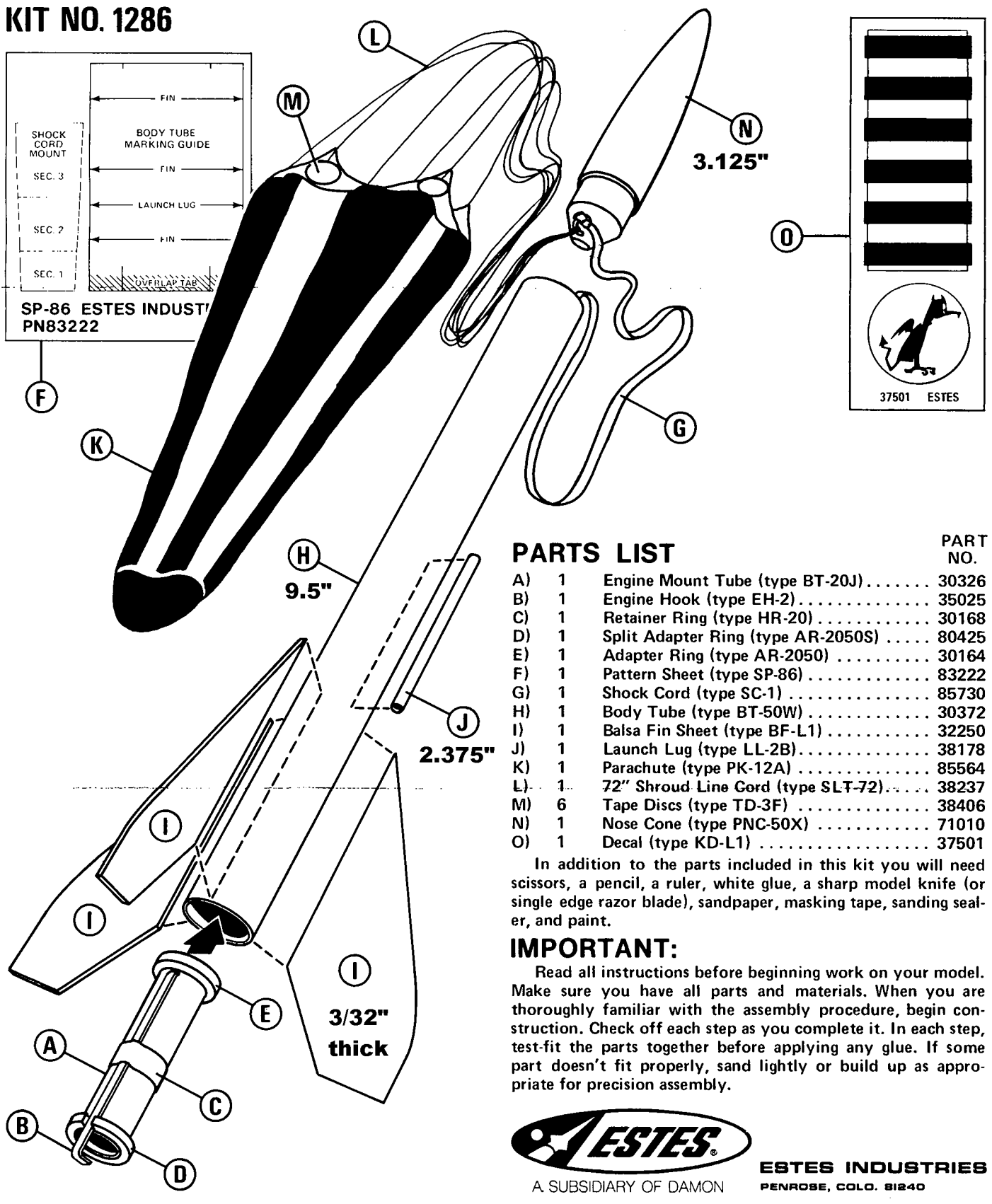

PARTS LIST

		PART NO.
A)	1	Engine Mount Tube (type BT-20J) 30326
B)	1	Engine Hook (type EH-2) 35025
C)	1	Retainer Ring (type HR-20) 30168
D)	1	Split Adapter Ring (type AR-2050S) 80425
E)	1	Adapter Ring (type AR-2050) 30164
F)	1	Pattern Sheet (type SP-86) 83222
G)	1	Shock Cord (type SC-1) 85730
H)	1	Body Tube (type BT-50W) 30372
I)	1	Balsa Fin Sheet (type BF-L1) 32250
J)	1	Launch Lug (type LL-2B) 38178
K)	1	Parachute (type PK-12A) 85564
L)	1	72" Shroud Line Cord (type SLT-72) 38237
M)	6	Tape Discs (type TD-3F) 38406
N)	1	Nose Cone (type PNC-50X) 71010
O)	1	Decal (type KD-L1) 37501

In addition to the parts included in this kit you will need scissors, a pencil, a ruler, white glue, a sharp model knife (or single edge razor blade), sandpaper, masking tape, sanding sealer, and paint.

IMPORTANT:

Read all instructions before beginning work on your model. Make sure you have all parts and materials. When you are thoroughly familiar with the assembly procedure, begin construction. Check off each step as you complete it. In each step, test-fit the parts together before applying any glue. If some part doesn't fit properly, sand lightly or build up as appropriate for precision assembly.



A SUBSIDIARY OF DAMON

ESTES INDUSTRIES
PENROBE, COLO. 81240

PEEL DECAL FROM BACKING.
FOR ACCURATE POSITIONING AS
SHOWN ON DECOR LAYOUT,
DIP DECAL IN MILD SOAP
SOLUTION.

APPLY DECAL TO MODEL.

SMOOTH OUT ANY
BUBBLES WITH A DRY RAG.

14 When all paint is dry, apply decals (part O). Peel a decal section from the backing, dip it in mildly soapy water, and position it on the model. Blot excess water away. For best results, let the model dry overnight and apply a coat of clear spray to protect paint and decals.

DECOR LAYOUT

BASE COLOR YELLOW

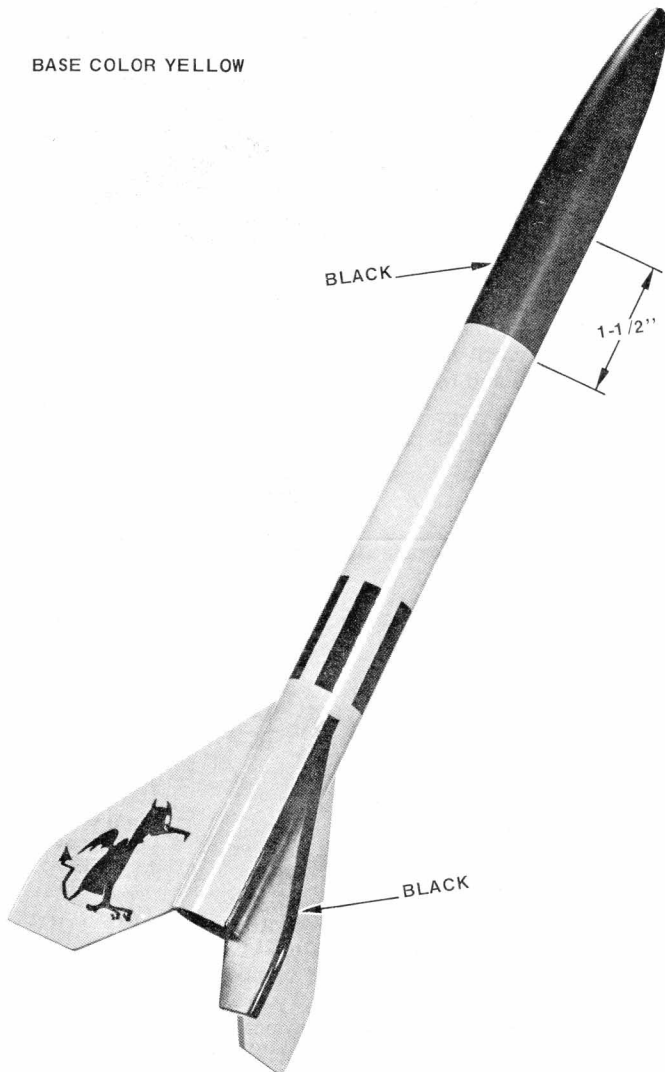

COUNTDOWN CHECKLIST

Be sure to follow the HIAA - NAR Model Rocketry Safety Code when carrying out all your model rocketry activities.

T-14 Pack four squares of loosely crumpled recovery wadding into body tube..



FOLD AND WRAP
SHROUD LINES
AROUND
PARACHUTE



INSERT AFTER
WADDING

T-13 Fold the parachute into a triangular shape. Roll 'chute tightly as shown and wrap shroud lines around it. If 'chute is too large, unroll it and repack until it slides easily into rocket. A fit that is too tight may prevent parachute from ejecting properly.

NOTE: DO NOT pack parachute until you are actually ready to launch. For maximum parachute reliability, lightly dust the 'chute with ordinary talcum powder before each flight, especially in cold weather.

T-12 Pack shock cord neatly into rocket, then slide nose cone into place. Nose cone should separate easily from rocket body tube, but should not be extremely loose. If it is too tight, sand inside of body tube end and shoulder of nose cone with extra fine sandpaper.

If nose cone is too loose, add a wrapping of transparent tape or masking tape to the shoulder of the nose cone.

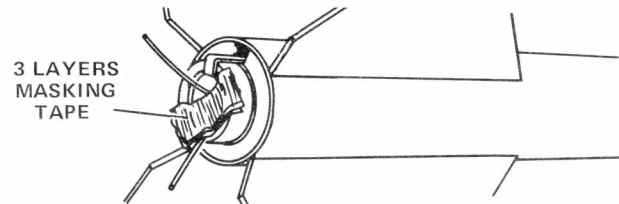

T-11 Select an engine and install an igniter as directed in the engine instructions. Engines recommended for use with this rocket are the 1/2A6-2, A8-3, B4-4, B6-4, and C6-5 made by Estes.

Use an A8-3 engine for your first flight.

T-10 Insert engine into rocket. Engine hook must latch securely over end of engine.

T-9 Disarm the launch panel--remove safety key.

T-8 Place rocket on launch pad, making sure rocket slides freely on launch rod. Clean the micro-clips and attach them to the igniter.

T-7 Clear the launch area, alert recovery crew and trackers. Check for low flying aircraft and unauthorized persons in the recovery area.

T-6 Arm the launch panel--insert safety key.

5 4 3 2 1 LAUNCH!!

MISFIRE PROCEDURE

Occasionally the igniter will heat and burn into two pieces without igniting the engine. This is almost always caused by a failure to install it correctly. Disarm the launch panel, remove the model, clean the igniter residue from the nozzle, and install a new igniter. Follow the launching procedure again.

SCAMP ASSEMBLY INSTRUCTIONS

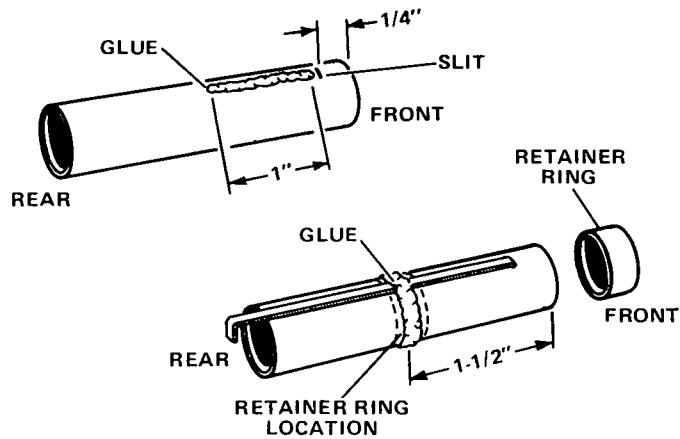

1 Cut a 1/8" long slit in the engine mount tube (part A), 1/4" from one end as shown. Apply a 1" long line of glue to the tube as shown. Push one end of the engine hook (part B) into the slit and press the main part of the hook into the glue. Apply a line of glue around the middle of the tube and slide the retainer ring (part C) over tube and hook onto the glue.

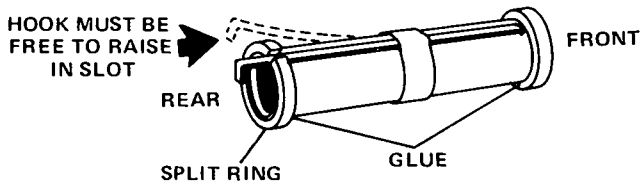

2 Glue the split adapter ring (part D) to the engine mount tube even with the rear end (the end with the over-hanging hook) so the slot is over the hook. Avoid getting glue in the slot. Glue the other ring (part E) to the front of the engine mount against the end of the hook as shown.

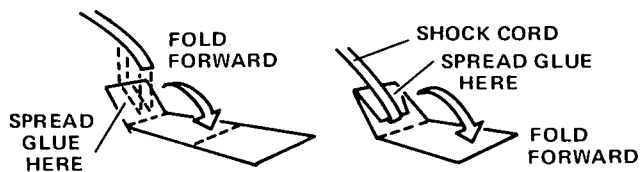

3 Cut out the shock cord mount from the pattern sheet (part F). Crease it on the dotted lines by folding. Spread glue on the first section (1) and lay the end of the shock cord (part G) into the glue. Fold over and apply glue to the back of the first section and the exposed part of section 2. Lay the shock cord as shown and fold over again. Clamp the unit together with your fingers until the glue sets.

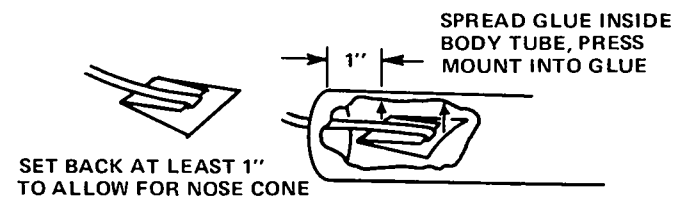

4 Apply glue to the inside of the body tube (part H) at one end over an area about 1" to 2" from one end. The glued area should be the same size as the shock cord mount. Press the mount into the glue as shown and hold it until the glue sets.

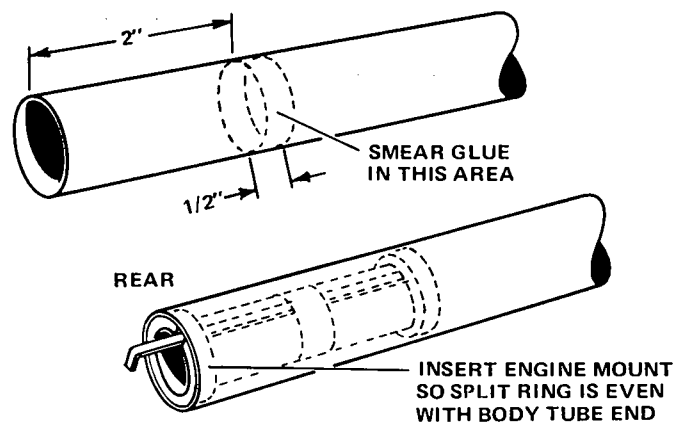

5 Smear glue around the inside of the other end of the body tube to cover an area about 2" to 2-1/2" from the end of the tube. Immediately insert the engine mount unit, being careful to position it so the engine hook will stick out of the end of the tube. Push the engine mount in with one smooth motion until the ends of the tubes (and the split ring) are even.

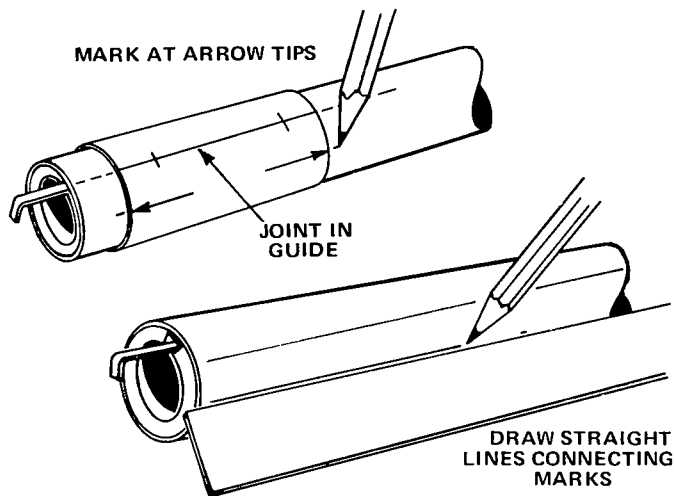

6 Cut out the body tube marking guide from the pattern sheet. Wrap it around the rear of the body so the joint in the guide is in line with the engine hook. Mark the tube at each arrow point, front and rear. Draw a straight line connecting each matching front and rear mark. (Use a ruler when drawing lines.) Extend the launch lug line forward 5".

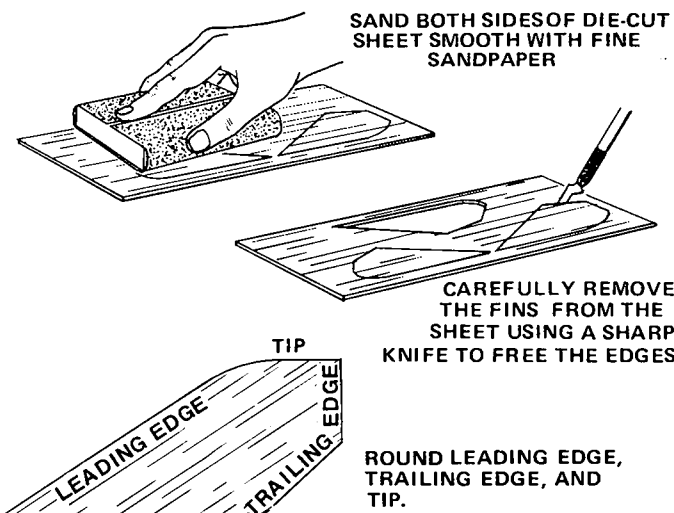

7 Fine-sand the balsa sheet (part I), then carefully remove the die-cut fins from the sheet. Free the edges with a sharp knife. Sand the leading, trailing, and tip edges of the fins round. Leave the other edges square.

RUB A LINE OF GLUE INTO
ROOT EDGE OF EACH FIN

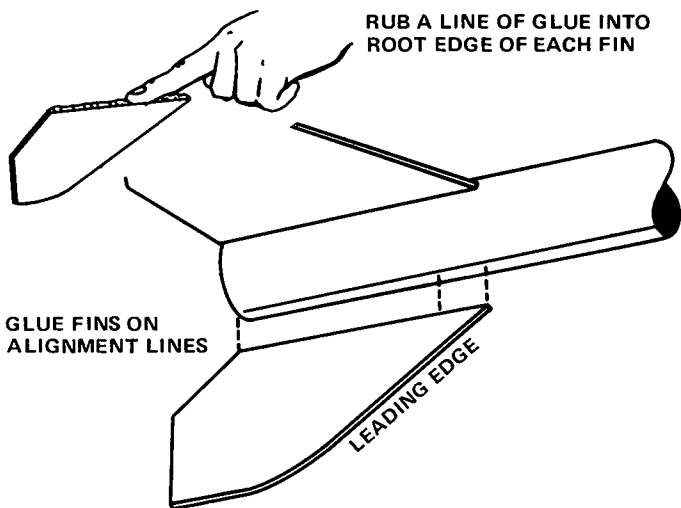

GLUE FINS ON
ALIGNMENT LINES

LEADING EDGE

8 Rub a line of glue into the root edge of each fin and allow to dry. Glue the fins to the body on the fin alignment lines drawn in step 6. Refer to the illustration to be sure you position the fins correctly. Adjust the fins so they project straight away from the body tube. Do not set the rocket on its fins while the glue is wet.

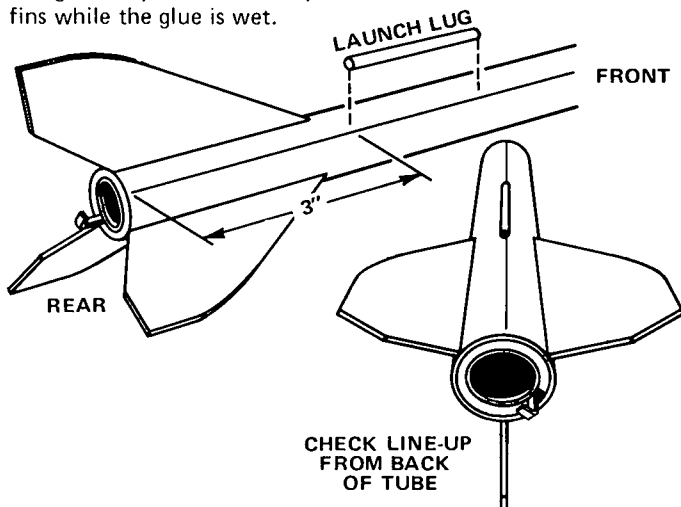

CHECK LINE-UP
FROM BACK
OF TUBE

9 Glue the launch lug (part J) to the body on its line. The rear of the lug should be 3" from the rear of the body. Align it straight on the body.

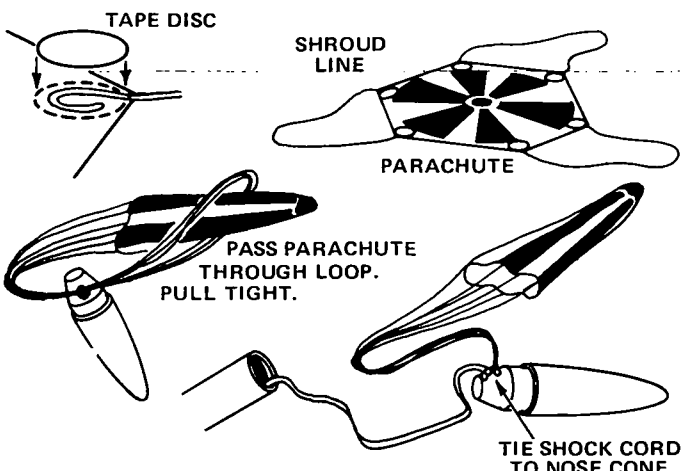

10 Cut out the parachute (part K) on its edge lines. Cut three 24" lengths of shroud line (part L). Attach line ends to the top of the parachute with tape discs (part M) as shown. Pass the shroud line loops through the ring on the nose cone (part N). Pass the parachute through the loop ends and draw the lines tight against the ring. Set the knot with a drop of glue. Tie the free end of the shock cord to the nose cone.

FILLETS SHOWN ARE
SLIGHTLY EXAGGERATED

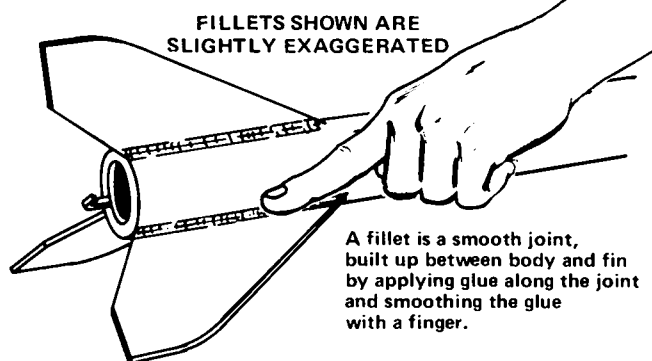

A fillet is a smooth joint, built up between body and fin by applying glue along the joint and smoothing the glue with a finger.

11 Apply a glue "fillet" to each fin joint. Holding the rocket horizontally (level), apply a line of glue to both sides of each joint. Smooth out the glue with your finger. Keep the rocket level until the glue dries.

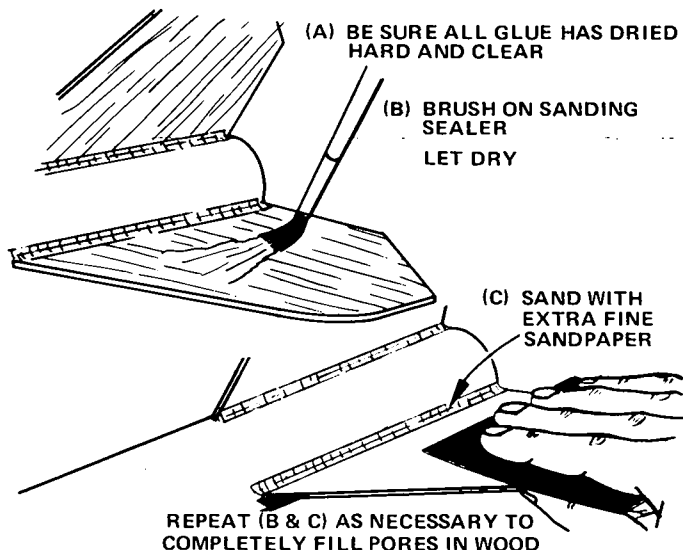

REPEAT (B & C) AS NECESSARY TO COMPLETELY FILL PORES IN WOOD

12 When all glue on the outside of the model is dry, prepare the balsa parts for painting. Apply at least two coats of sanding sealer to the fins. Let dry and sand lightly between coats. Do this until the tiny holes in the wood are filled and everything looks and feels smooth.

SPRAY PAINT FOR BEST RESULTS. USE STICK OR DOWEL FOR ROCKET HOLDER. SHAKE CAN BEFORE SPRAYING.

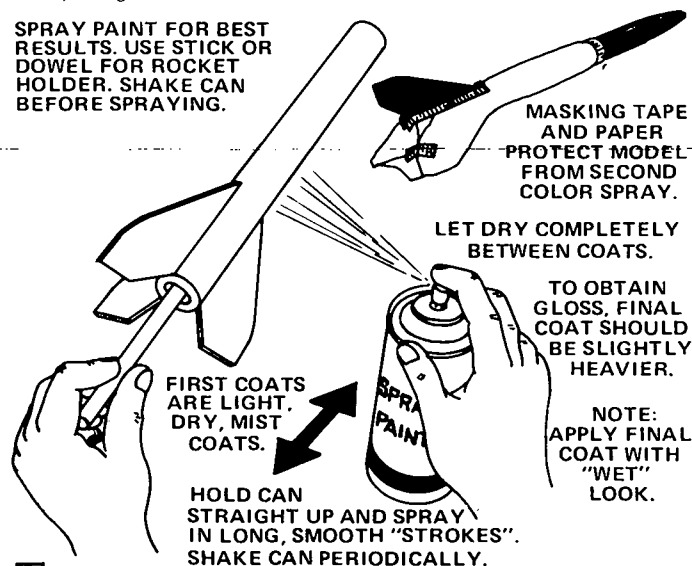

13 After the sanding sealer is completely dry, paint the entire model yellow. Let the yellow dry overnight. Apply masking tape and paper to cover and protect the areas which will remain yellow (See the Decor Layout illustration.) Paint one fin, the nose cone, and the front 1-1/2" of the body black. Carefully remove the masking tape and paper as soon as the paint is dry.

ONE INCH

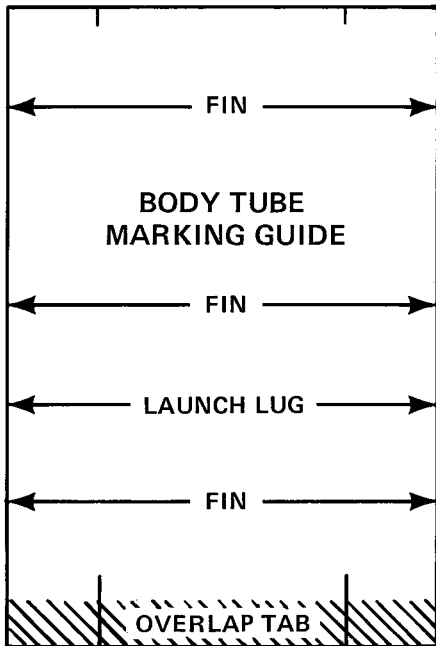

Scanned for JimZ's site 15 April 2002 by John Joseph Original kit supplied by Mario Anleu

**SP-86 ESTES INDUSTRIES
PN83222**

One Inch

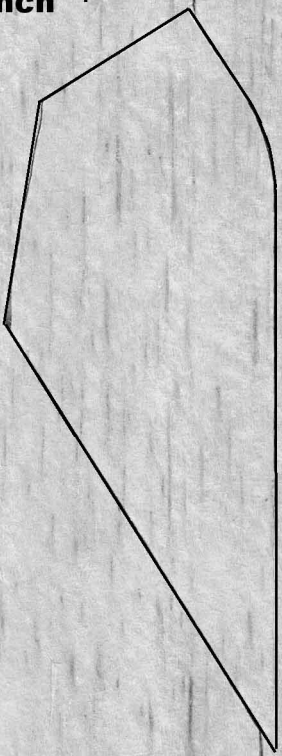

MADE IN U.S.A.

1

2

3

4



**Estes SCAMP kit
Peel-n-stick Decals**

**Scanned for JimZ's site
By John Joseph 15 April 2002**

**Original kit supplied by
Mario Anleu**



Custom SCAMP decal sheet done for JimZ's site By John Joseph 15 April 2002

Scamp figure made same size as figure on fin on package insert.

2 Figures instead of one (so you can do both sides of fin).

"Scamp" lettering added so you can add kit name to both sides of fin or rocket body.

ONE INCH

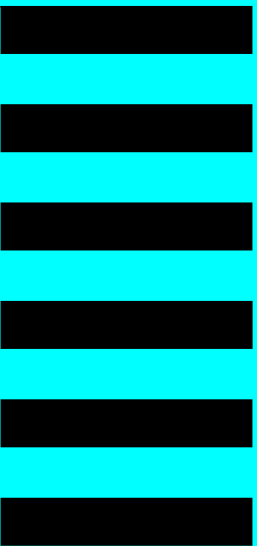

SCAMP

SCAMP

SCAMP



- Hi-Performance Plastic Nose Cone
- 12" Parachute Recovery
- Self-Stick Decals
- Die-Cut Balsa Fins
- Quick Change Engine Mount



SKILL LEVEL

1-Beginner 2-Intermediate 3-Curious 4-Advanced 5-Expert

SPECIFICATIONS

Length 13.75" (34.3cm)
Body Dia. 0.875" (22.1mm)

Weight 0.805 oz. (22.8g)
12" Parachute Recovery

RECOMMENDED ENGINES

13262 A83 814 864
814-5 C6-5
Use A83 for first flight.

This is a hobby kit requiring construction. Launch system, engine and glue are not included with this kit.

#1286



ESTES INDUSTRIES

10000 W. 10th Street, Grand Rapids, MI 49508

©1998 by Estes Industries. All Rights Reserved. Printed in the USA. Design and artwork by Mark Miller.