





Mean Machine™

#1295

FLYING MODEL ROCKET

Estes Industries
1295 H Street
Penrose, CO 81240

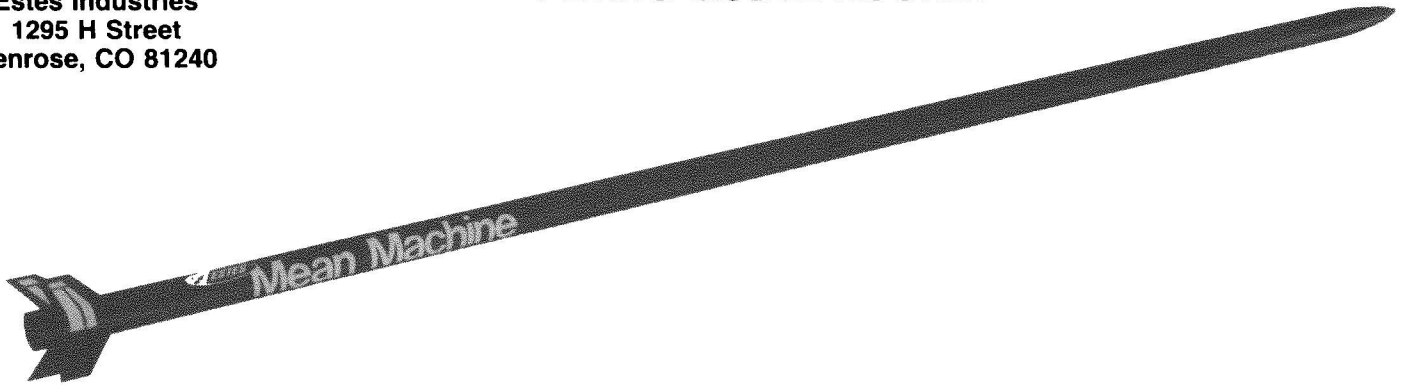

ASSEMBLY TIP

Read all instructions before beginning work on your model. Make sure you have all parts and supplies. Test-fit all parts together before applying any glue. If any parts don't fit properly, sand as required for precision assembly.

PARTS AND SUPPLIES

Locate the parts shown below and lay them out on the table in front of you. In addition to the parts included in the kit you will also need:

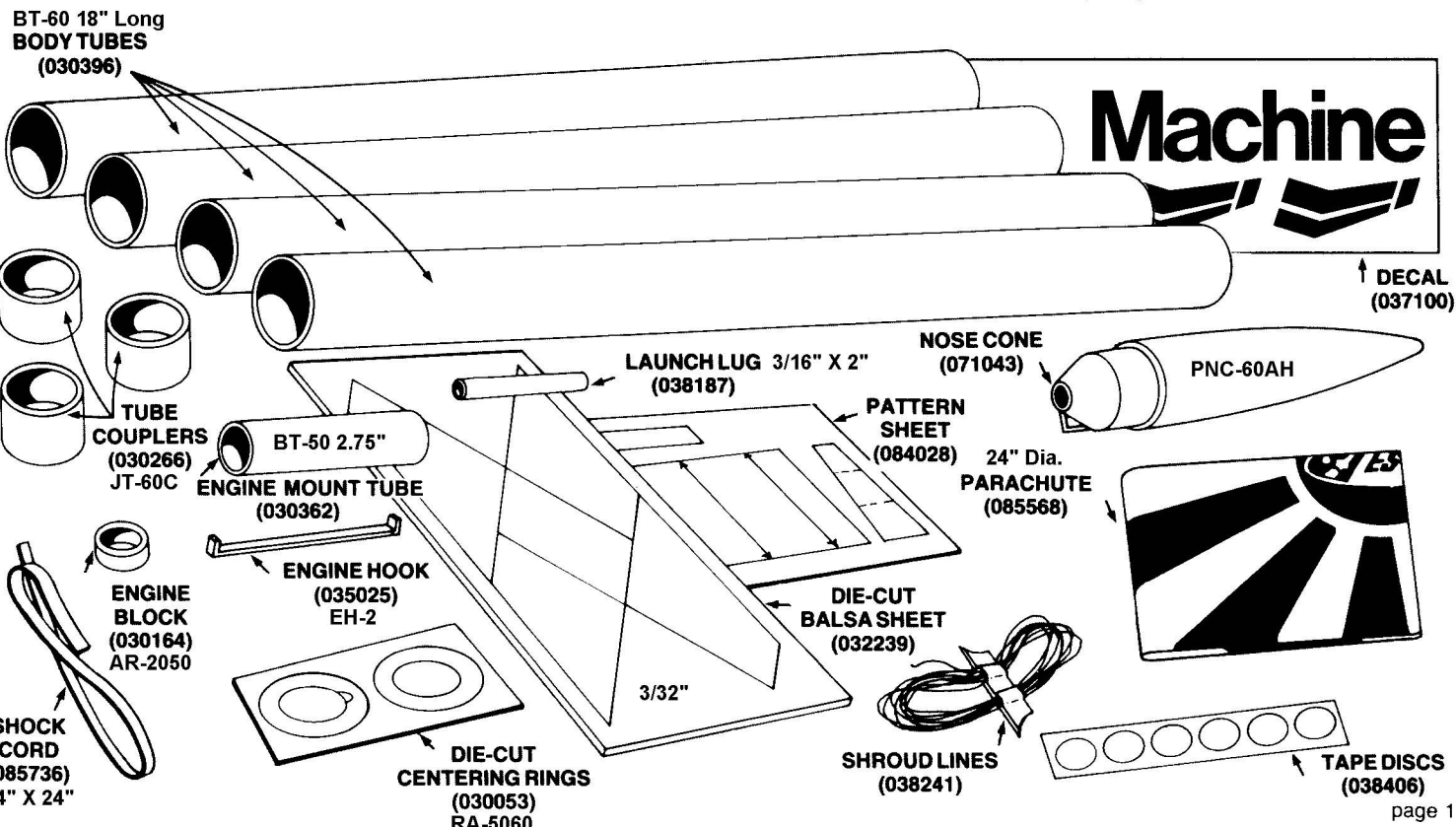

ROCKET ASSEMBLY

1

- Cut a 1/8" (3 mm) long slit 1/4" (6 mm) from one end of engine mount tube.
- Cut out the hold-down strap from pattern sheet.
- Apply 1 1/2" (38 mm) of glue to tube as shown. Push engine hook into slit and into glue. Apply glue to one side of hold-down strap and wrap it tightly around middle of tube and engine hook.
- Smear glue around inside of forward end of tube. Insert engine block and push in until it stops at engine hook.
- Remove centering rings from die-cut card. Glue one ring to each end of tube. Place notch in notched ring over engine hook. Allow this assembly to dry before completing next step.

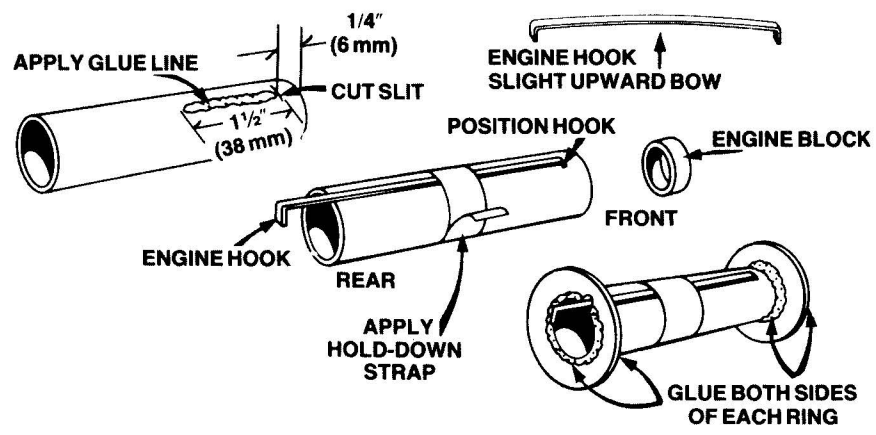

2

- Using a piece of scrap balsa, smear glue inside body tube 2" (51 mm) from one end.
- Push engine mount in until ring is 1/16" (2 mm) into body tube.

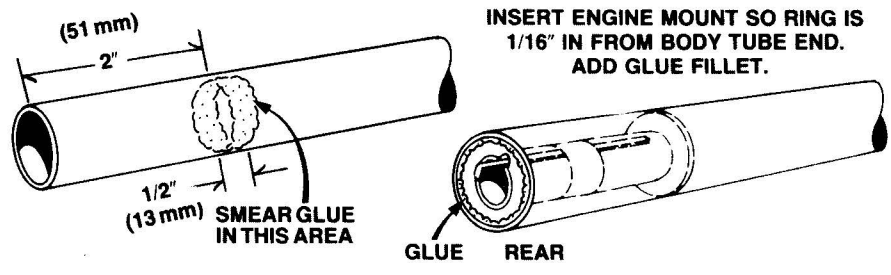

3

- Cut out body tube marking guide from pattern sheet.
- Wrap guide around tube 1" (25 mm) from rear and mark tube at arrows.
- Draw straight lines connecting each pair of marks.
- Extend launch lug line full length of tube.

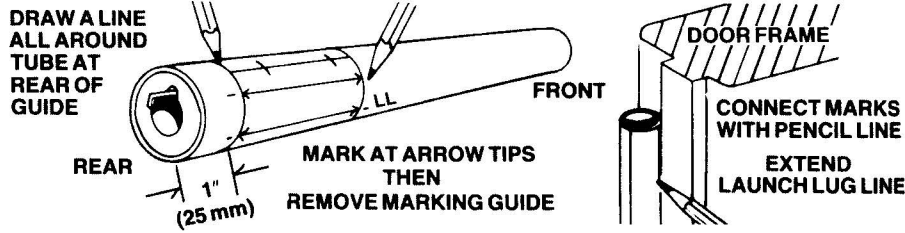

4

- Fine sand balsa die-cut sheet. Carefully remove fins by freeing edges with sharp knife.
- Stack fins together. Sand all edges smooth.
- Sand leading edges, trailing edges, and fin tips round.

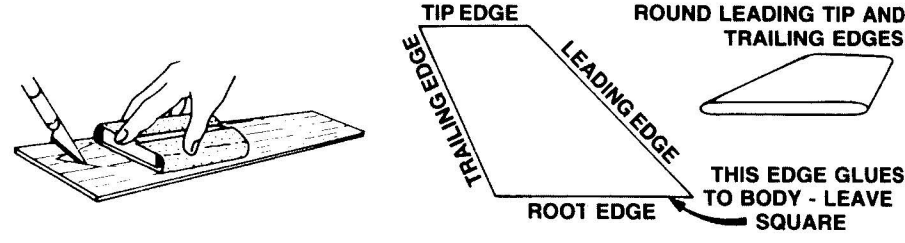

5

- Compare fins with pattern in previous step to find front (leading) and gluing (root) edges.
- Position and glue fins on alignment lines, each 1" (25 mm) from end of tube, one at a time. Let each dry several minutes before applying next one.
- Adjust fins to project straight out from tube.
- Do not set rocket on fins while glue is wet.

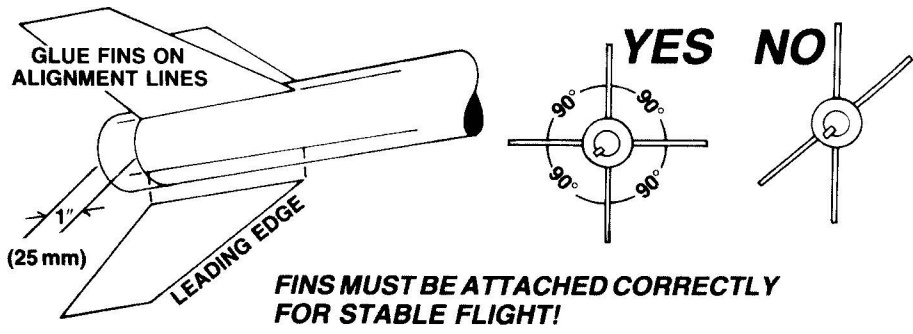

6

- Mark three tube couplers 3/4" (19 mm) from one edge.
- Smear glue about 1/4" (6 mm) inside forward end of finned body tube. Insert one coupler into tube to 3/4" (19 mm) mark. Be sure tube coupler is installed squarely.
- Smear glue and insert the remaining tube couplers into two of the three remaining body tubes per instruction of previous step. Be sure couplers are installed squarely. Allow glue to set before moving on to next step.

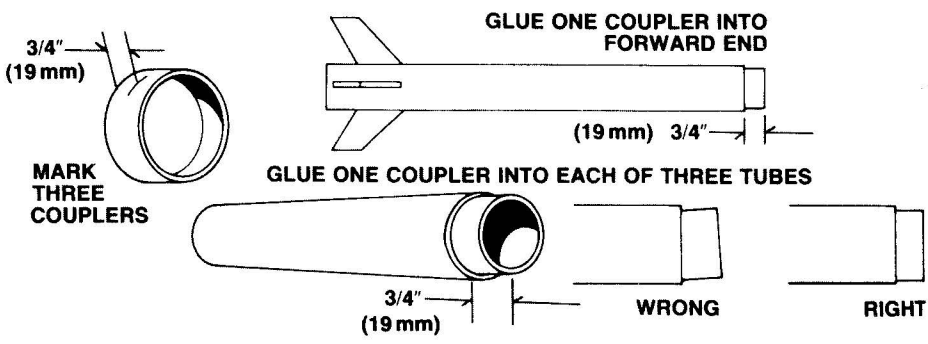

7

- A. Apply glue to inside of rear end of one tube.
- B. Slide tube over the coupler of finned tube in one smooth movement. Edges of tubes should touch all around.
- C. Sight along tubes while rotating rocket to make certain alignment of body tubes is perfectly straight.
- D. Assemble the rest of the tubes in same manner, always checking alignment of tubes with each additional tube.
- E. Lay rocket on a flat surface with fins over the edge while the glue dries.

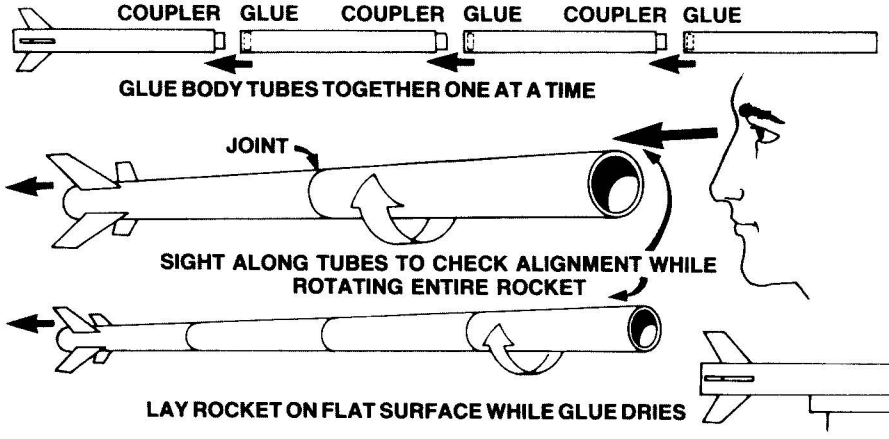

8

- A. Cut launch lug into two 1" (25 mm) lengths.
- B. Glue one launch lug straight on launch lug line 1" (25 mm) from rear of tube.
- C. Glue remaining lug on launch lug line with front edge even with joint in body tube. Align lugs straight on body tube.

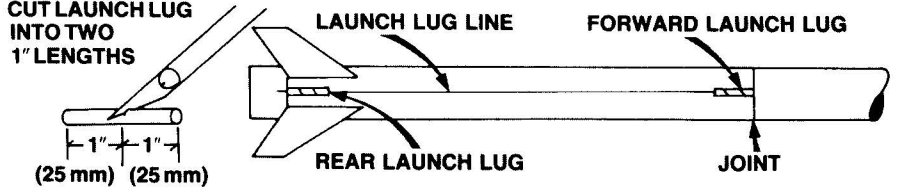

9

- A. Cut shock cord mount from pattern sheet.
- B. Crease on dotted lines by folding. Spread glue on section 1 and lay end of shock cord into glue. Fold over and apply glue to back of first section and exposed part of section 2. Lay shock cord as shown and fold mount over again.
- C. Clamp unit together with fingers until glue sets.

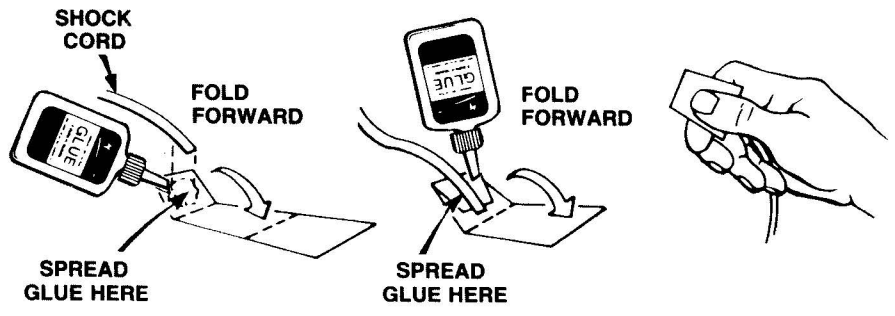

10

- A. Apply glue to inside front of body tube to cover an area no less than 1" (25 mm) to 2" (51 mm) from end. The glued area should be same size as shock cord mount.
- B. Press mount firmly into glue as shown.
- C. Hold until glue sets.

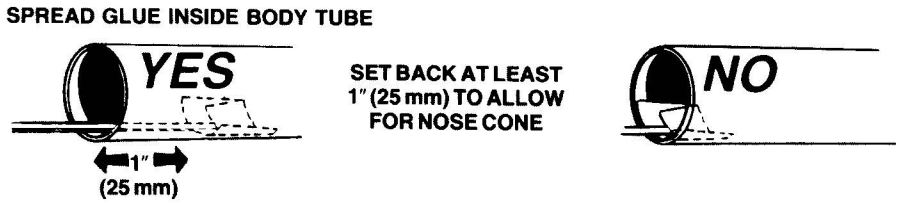

11

- A. Apply a glue reinforcement to each fin/body tube joint and each side of launch lug.
- B. Support rocket as shown until glue dries.



12

- A. Cut out parachute on edge lines.
- B. Cut three 36" (914 mm) lengths of shroud line.
- C. Form small loops with shroud line ends and press onto sticky side of tape discs.
- D. Attach tape discs with line ends to top of parachute as shown.
- E. Firmly press tape discs into place until both tape discs and parachute material are molded around shroud line loops.
- F. Pass shroud line loops through loop on nose cone. Pass parachute through loop ends and pull lines against the nose cone.
- G. Tie free end of shock cord to nose cone eyelet.

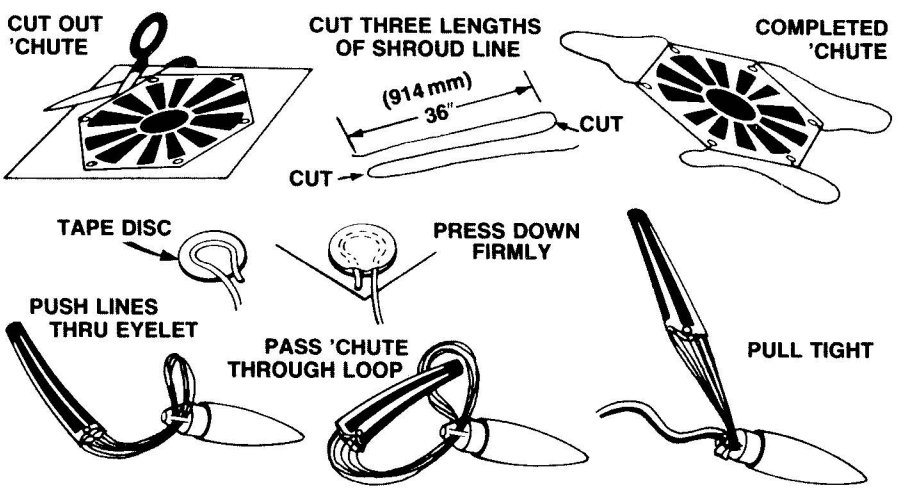

FINISHING YOUR ROCKET

Apply sanding sealer to fins. When sealer is dry, lightly sand parts. Repeat sealing and sanding until balsa grain lines are filled. Spray paint entire rocket with gloss black enamel. Follow instructions on spray can for best results. Let paint dry. Apply decals as shown. Cut each decal out, dip in lukewarm water for 20 seconds, and hold until it uncurls. Slip decal off backing sheet onto model. Blot away excess water. Let decals dry overnight and apply a coat of clear spray paint to protect decals.

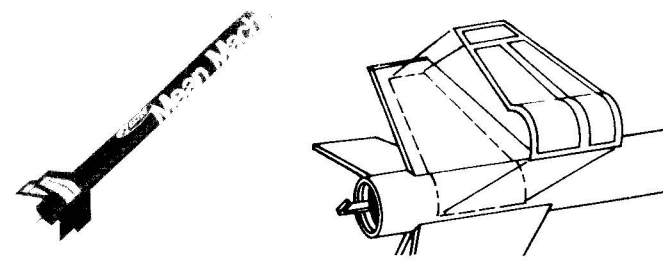

ROCKET PREFLIGHT

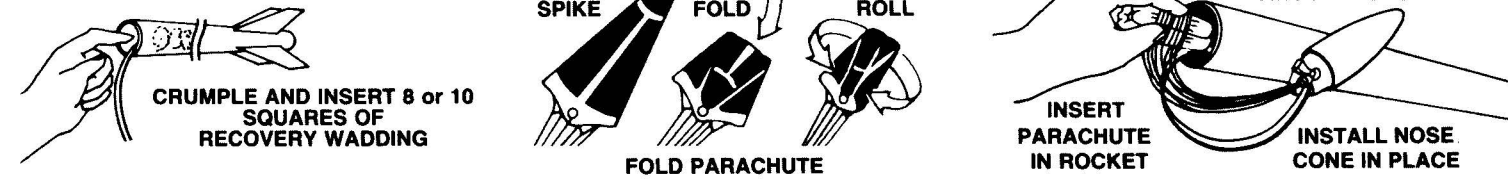

PREPARE ENGINE

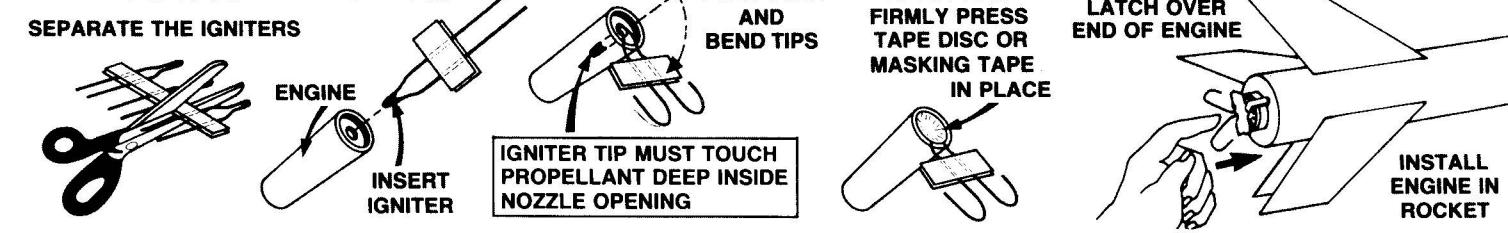

LAUNCH SUPPLIES

To launch your rocket you will need the following items:
 —An Estes model rocket launch system and launch pad
 —Estes Recovery Wadding (No. 2274)
 —3/16 inch Maxi-Rod (No.2244)
 —Recommended Engine: D12-5 *Use with Estes products only.*

FLYING YOUR ROCKET

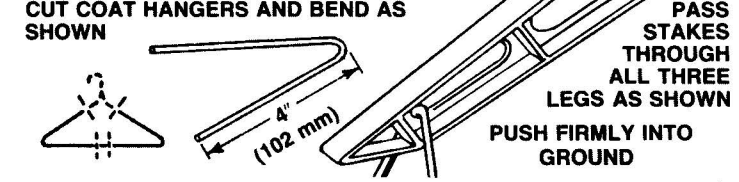

Due to the rocket's length, additional launch pad stability is required for safety. Weight down or secure your pad with bricks or coat hanger stakes using the following procedure.
 Cut three hold-down stakes from coat hangers as shown. Adjust the launch pad on level ground. Pass the stake hooks through the launch pad legs, then push the stakes firmly into the ground. Check to be sure the launch pad is held down securely before proceeding.

Choose a large field away from power lines, tall trees, and low flying aircraft. Try to find a field at least 500 feet (152 meters) square. The larger the launch area, the better your chance of recovering your rocket. Football fields and playgrounds are great.

MISFIRES

Failure of the model rocket engine to ignite is nearly always caused by incorrect igniter installation. An Estes igniter will function properly even if the coated tip is chipped. However, if the coated tip is not in direct contact with the engine propellant, it will only heat and not ignite the engine.

When an ignition failure occurs, remove the safety key from the launch control system and wait one minute before approaching the rocket. Remove the expended igniter from the engine and install a new one. Be certain the coated tip is in direct contact with the engine propellant, then tape the igniter leads firmly to base of engine as illustrated above. Repeat the countdown and launch procedure.

Always follow the NAR* MODEL ROCKETRY SAFETY CODE while participating in any model rocketry activities.

*National Association of Rocketry
 page 4

COUNTDOWN AND LAUNCH

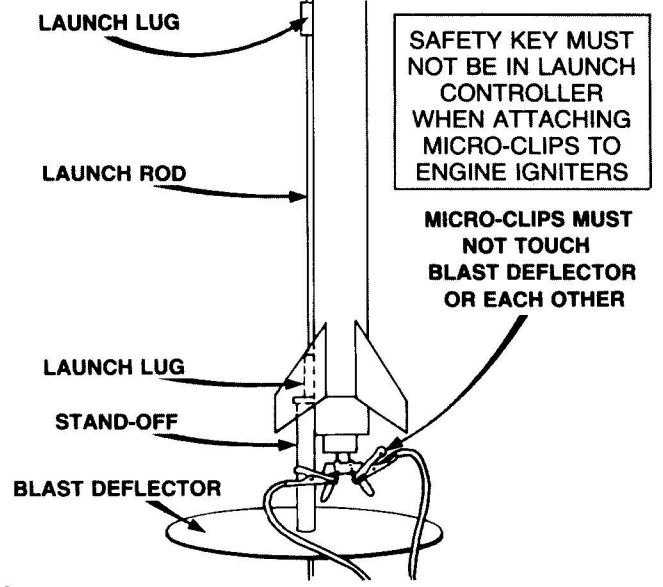

- ⑩ BE CERTAIN SAFETY KEY IS NOT IN LAUNCH CONTROLLER.
 - ⑨ Remove safety cap and slide launch lug over launch rod to place rocket on launch pad. Make sure the rocket slides freely on the launch rod.
 - ⑧ Attach micro-clips to the igniter wires. Arrange the clips so they do not touch each other or the metal blast deflector. Attach clips as close to protective tape on igniter as possible.
 - ⑦ Move back from your rocket as far as launch wire will permit (at least 15 feet - 5 meters).
 - ⑥ INSERT SAFETY KEY to arm the launch controller.
- Give audible countdown 5...4...3...2...1

LAUNCH!! PUSH AND HOLD LAUNCH BUTTON UNTIL ENGINE IGNITES

REMOVE SAFETY KEY FROM LAUNCH CONTROLLER. REPLACE SAFETY KEY AND SAFETY CAP ON LAUNCH ROD.

HOLD-DOWN STRAP

SP-95

PN 84028

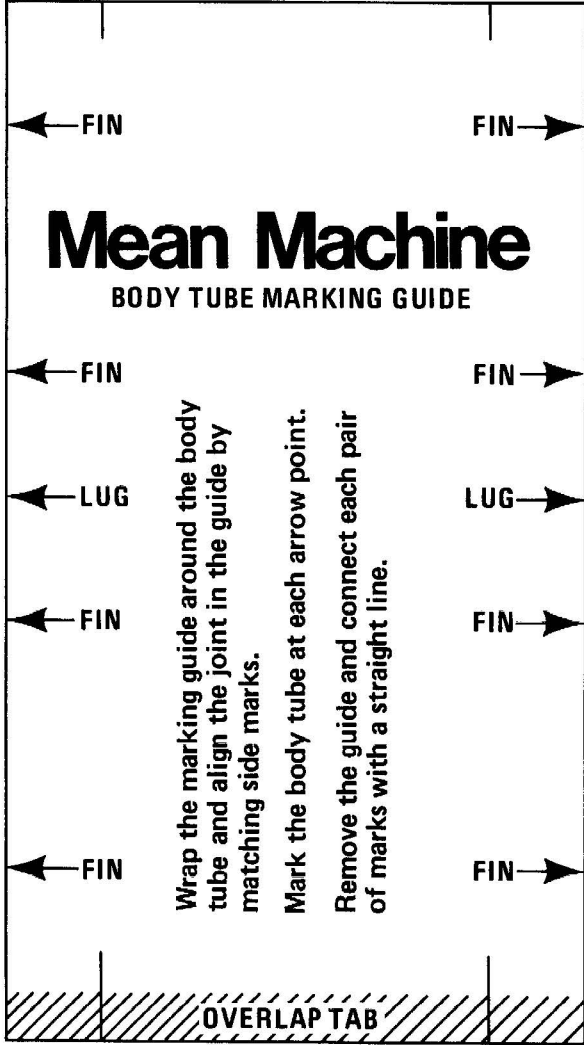

SEC. 1

SEC. 2

SEC. 3

SHOCK CORD MOUNT

3/32"
Balsa

1 Inch

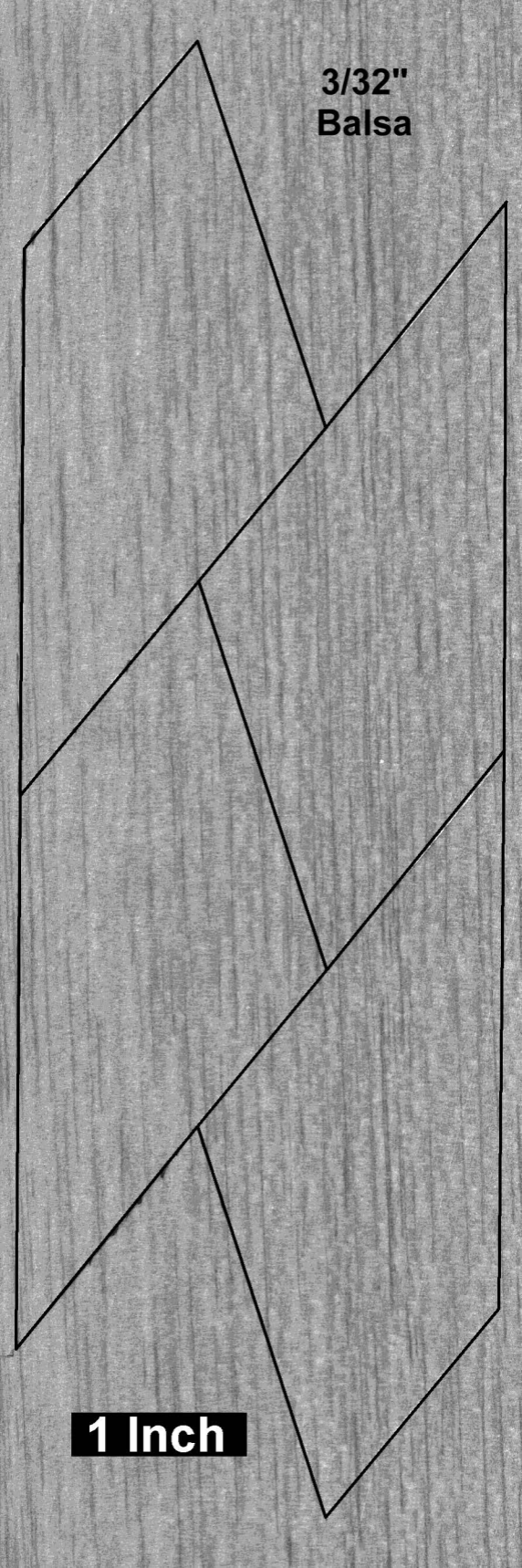



Mesari Machine

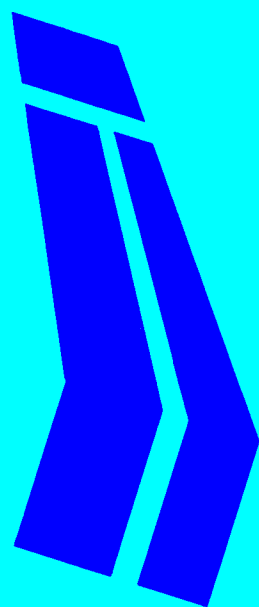
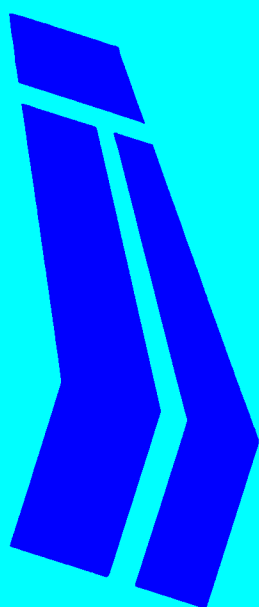
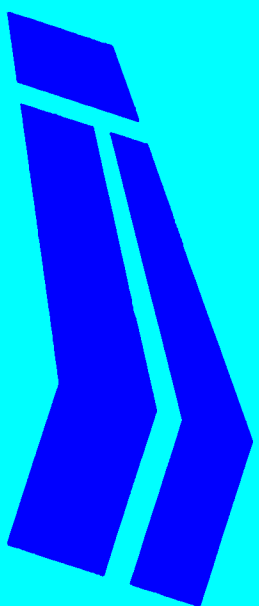
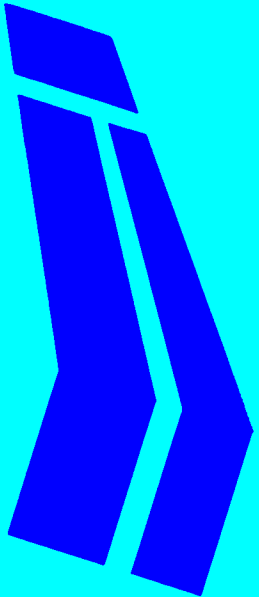

ESTES INDUSTRIES
PN 37100

600 DPI

Mean Machine

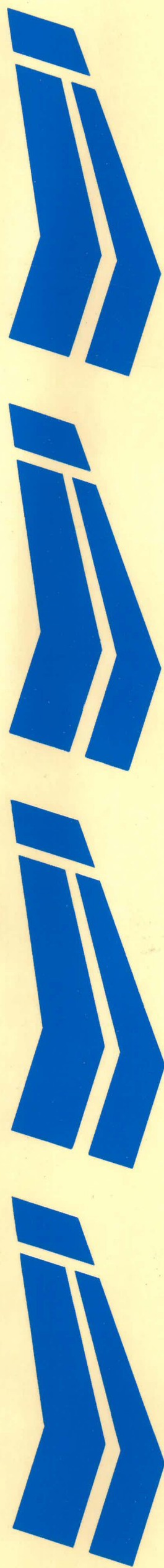

ESTES INDUSTRIES
PN 37100

600 DPI

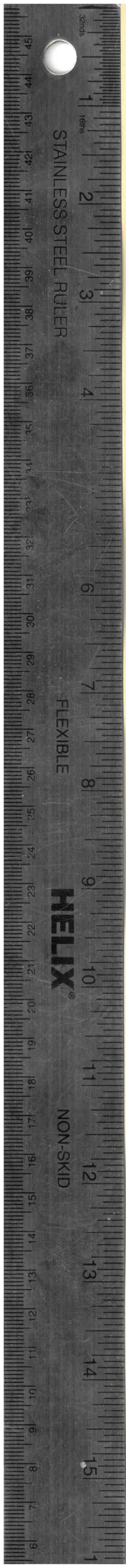

Mean Machine

FLYING
MODEL
ROCKET

SKILL LEVEL 3

- Great for Intermediate Hobbyists
- High Altitude
- Heavy Recovery
- Flights Over 100 Feet
- 10" Diameter Powered Rocket

FOR MORE INFORMATION
VISIT US AT
www.meanmachines.com

OR CALL 1-800-828-8888
TOLL FREE

OR VISIT US AT
www.meanmachines.com

OR VISIT US AT
www.meanmachines.com

OR VISIT US AT
www.meanmachines.com

OR VISIT US AT
www.meanmachines.com

OR VISIT US AT
www.meanmachines.com

OR VISIT US AT
www.meanmachines.com

OR VISIT US AT
www.meanmachines.com

OR VISIT US AT
www.meanmachines.com

OR VISIT US AT
www.meanmachines.com

OR VISIT US AT
www.meanmachines.com

OVER
100
FEET
TALL



© 2004 Mean Machines, Inc. All rights reserved.