

BATTLESTAR GALACTICA

2 engines and
1 nose fin (one not included)
1 servomotor
1 servomotor
1 servomotor
1 servomotor

SKILL LEVEL 2

Designed for individuals age
12 and older. Requires experience.

This is a hobby kit requiring assembly
instructions for ages 12 to adult. Engines,
servos, servos, glue and finishing supplies are
not included. Additional equipment for those
under 12 years of age (such as glue sticks, glue pots,

VIDEON
FLYING MODEL ROCKET

ESTES

© 1999 Estes Industries, Inc. All rights reserved.

BATTLESTAR GALACTICA™

KIT NO. 1310
SKILL LEVEL 2

COLONIAL VIPER™

IMPORTANT:

Read all instructions before beginning work on your model. Make sure you have all parts and materials. When you are thoroughly familiar with the assembly procedure, begin construction. Check off each step as you complete it. In each step, test-fit the parts together before applying any glue. If some part doesn't fit properly, sand lightly or build up as appropriate for precision assembly.

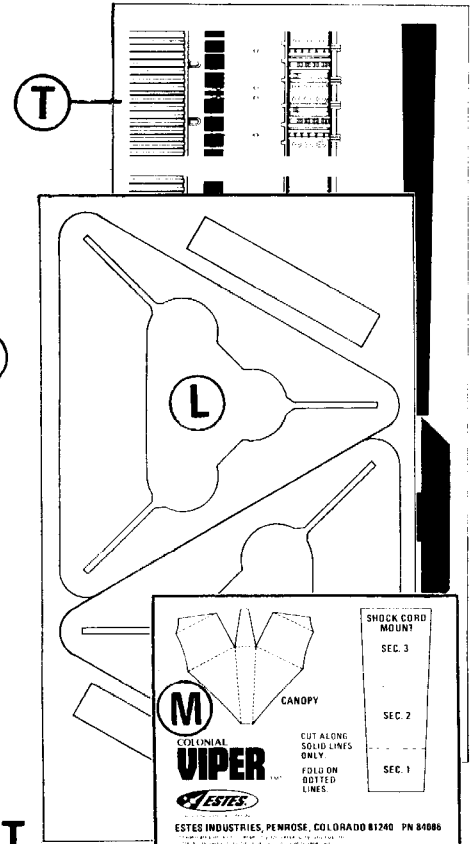
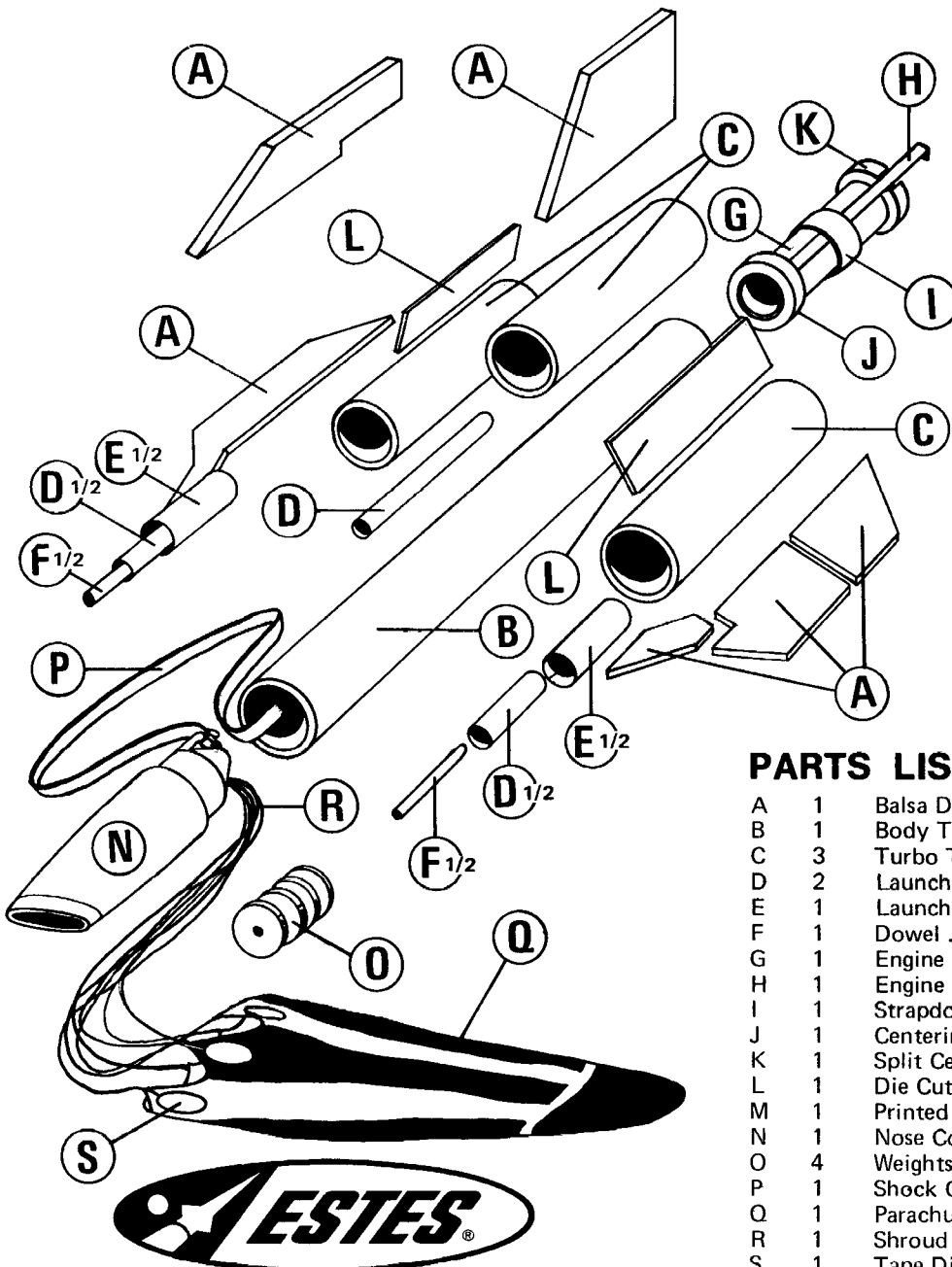

PARTS LIST

A	1	Balsa Die-Cut Sheet	32320
B	1	Body Tube (type BT-50W)	30372
C	3	Turbo Tube (type BT-52S)	30380
D	2	Launch Lug (type LL-2B)	38178
E	1	Launch Lug (type LL-3B)	38166
F	1	Dowel	85905
G	1	Engine Tube (type BT-20J)	30326
H	1	Engine Holder (type EH-2)	35025
I	1	Strapdown Ring (type HR-20)	30168
J	1	Centering Ring (type AR-2050)	30164
K	1	Split Centering Ring (type AR2050S)	80425
L	1	Die Cut Card Stock Sheet (type SP1310)	84087
M	1	Printed Paper Sheet (type SP1310A)	84086
N	1	Nose Cone (type PNC-50SV)	71002
O	4	Weights (type NCW-1A)	38280
P	1	Shock Cord (type SC-1)	85730
Q	1	Parachute (type PK-12A)	85564
R	1	Shroud Line (type SLT-72)	38237
S	1	Tape Discs (type TD-3F)	38406
T	1	Sheet of Pressure Sensitive Stickers	37551

A SUBSIDIARY OF DAMON

*Trademarks of and Licensed by Universal City Studios, Inc.
©1978 Universal City Studios, Inc. All rights reserved.

Materials needed to complete this model: modeling knife, "white" glue (Elmers, Wilhold, etc.), #320 grit fine sandpaper, balsa sanding sealer, gloss white spray paint, small bottle silver enamel, small paint brush, ruler & pencil.

ASSEMBLY INSTRUCTIONS

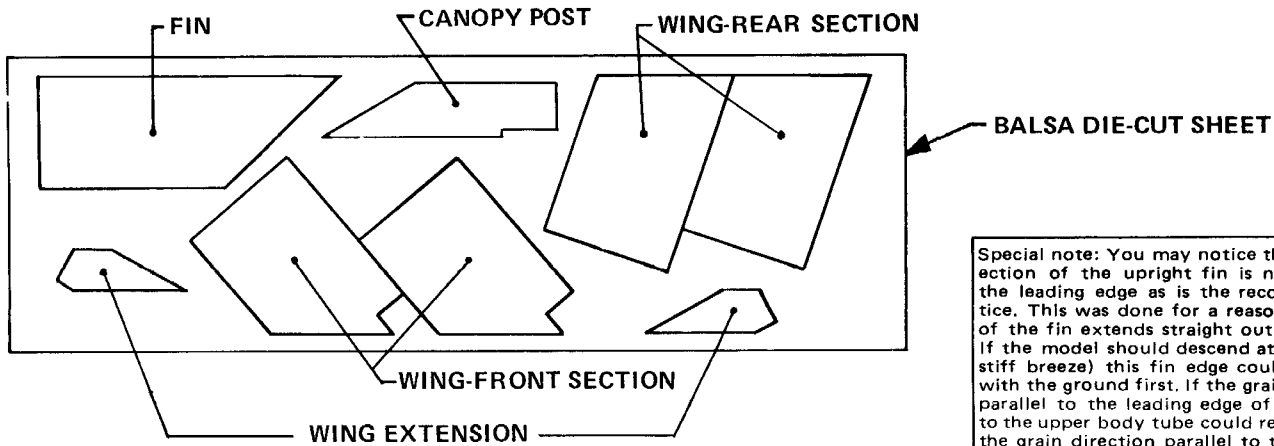

Special note: You may notice that the grain direction of the upright fin is not parallel with the leading edge as is the recommended practice. This was done for a reason. The rear edge of the fin extends straight out from the body. If the model should descend at an angle (as in a stiff breeze) this fin edge could make contact with the ground first. If the grain direction were parallel to the leading edge of the fin, damage to the upper body tube could result. By running the grain direction parallel to the body, the fin will most likely break off rather than transmitting shock to the body. Since it is much easier to glue the fin back in place than to rebuild the rocket body, the fin was designed in this manner.

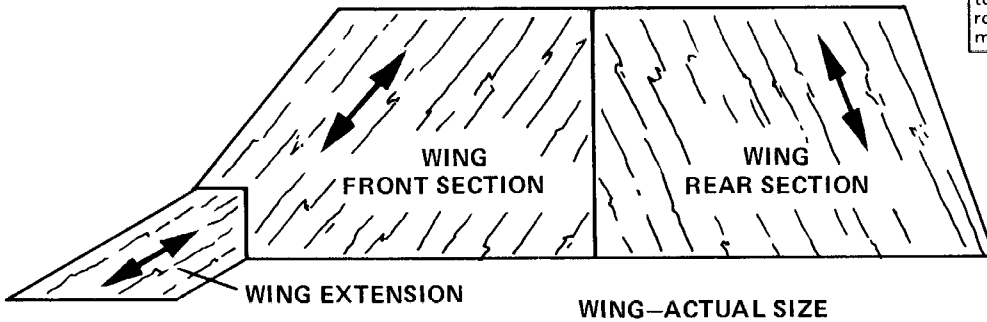

1 Locate the balsa die-cut sheet (part A). Using a sharp knife, carefully remove the parts from the sheet. Identify each part as it is removed. Lay the fin and canopy post aside for now.

Lay one set of wing parts over the template. Check the grain direction to make sure it is the same as indicated on the template. Place a piece of waxed paper or plastic wrap on a flat surface. Run a very light bead of glue along the edges of each wing piece where it glues to another piece. Wipe away excess glue, leaving a thin, smooth film on the gluing edges. Lay the parts on the plastic wrap but do not join them together.

Allow the glue to dry, then apply a second thin film of glue to the gluing edges and join the parts together. Check the parts against the template to make sure you have done the job correctly. Press the parts firmly together. Wipe away any excess glue from the surface, fold the plastic wrap over the wing and weight with a heavy book. Allow the glue to set for 45 minutes before disturbing. Repeat this step with the remaining wing.

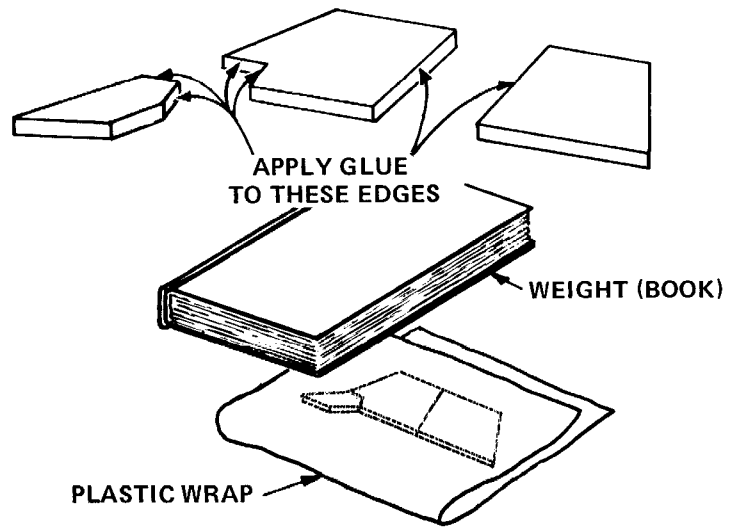

2 Locate the body tube (part B) and the three turbo tubes (part C). Place the body tube on a flat surface. Run a bead of glue along one side of a turbo tube and glue it to the side of the body tube with the ends even. Glue a second turbo tube to the other side of the body tube. Make sure all three tubes are resting flat on the surface and allow to set until the glue dries. Note that the body tube is slightly smaller in diameter than the turbo tubes. Place a mark on the top of the body tube so you do not accidentally turn it upside down when proceeding to the next step.

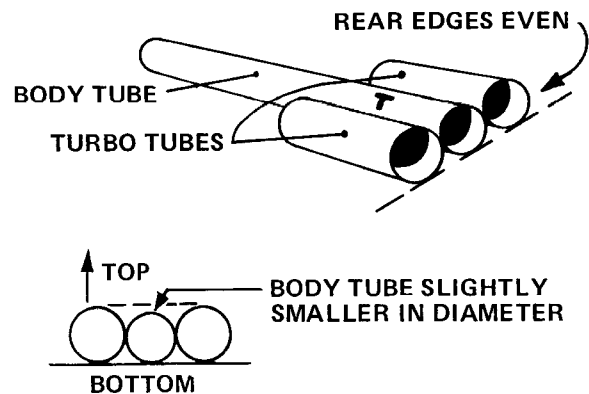

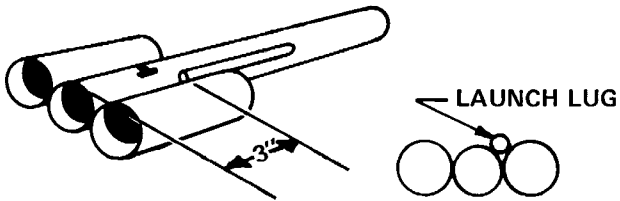

3 Glue a launch lug (part D) to the top of the body in the position shown. Make sure you use one of the two smaller launch lugs, not the large one.

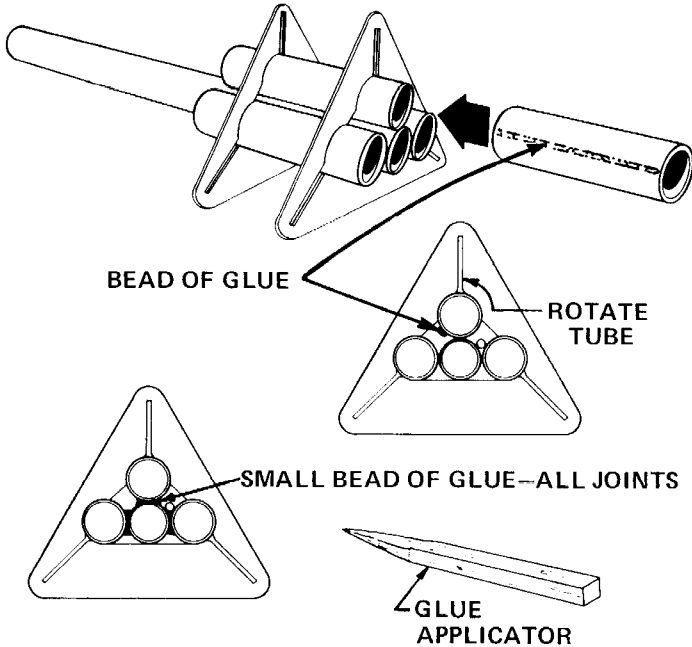

4 Locate the die-cut cardstock sheet (part L). Remove the two alignment guides from the sheet. Also, remove the two rectangular pieces and lay them aside for use later. Save the board from which these parts were removed. It will be used in step 8. Slip the guides onto the tube assembly in the position shown. Remember, the mark on the body tube should be on the top. Apply a bead of glue along the side of the remaining turbo tube. Carefully insert this tube into the alignment guide so the bead of glue does not contact the body tube. Push the turbo tube in until the rear edges of the tubes are even. Rotate the turbo tube so the bead of glue comes in contact with the body tube. To provide added strength, apply a small bead of glue to both sides of all body tube joints. Use a piece of scrap balsa with a sharpened end to apply the glue.

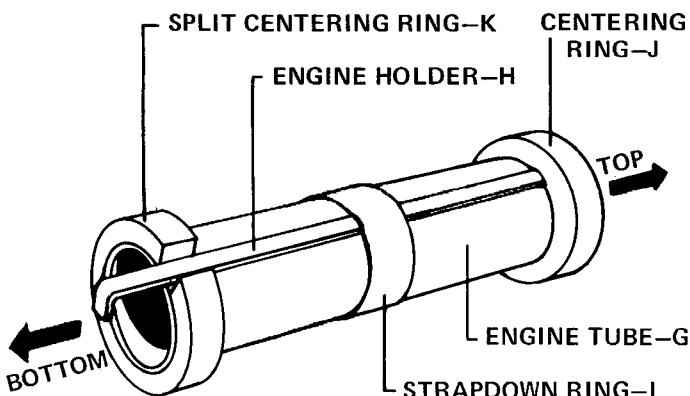

COMPLETED ENGINE MOUNT

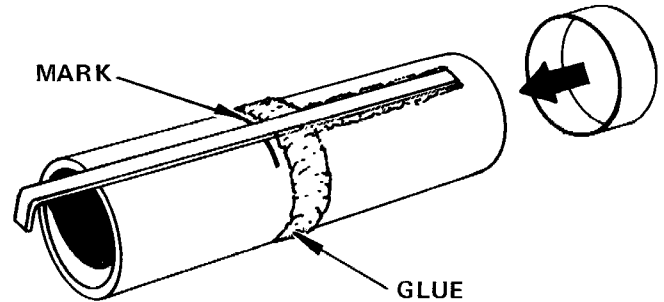
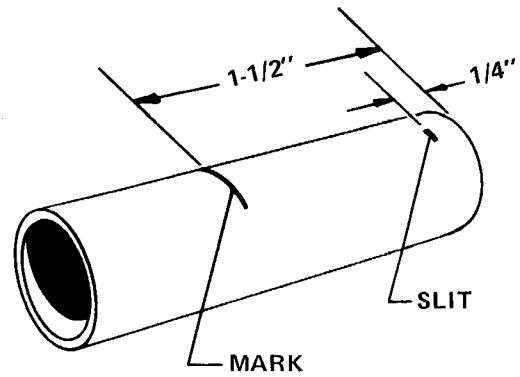

5 Locate the parts called out in the illustration below (left). Cut a 1/8" wide slit, 1/4" from the end of the tube and place a mark on the tube 1-1/2" from same end. Run a bead of glue from slit to mark. Place one end of engine holder in slit. Hold engine holder in place and run a bead of glue around tube above mark. Slide strapdown ring over top of tube and push down to mark. Glue centering ring to top and split ring to bottom of tube, flush with the ends.

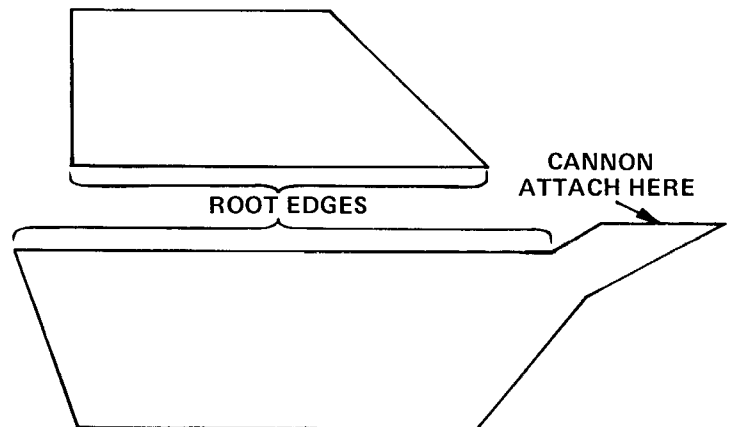

6 Remove the book-weights from the wings. If the glue is thoroughly dry, proceed with this step. If not, skip ahead and come back to this step later. Lightly sand sides and edges of fin and both wings. Keep all edges square. Apply sanding sealer to all surfaces except the root edges (edges that glue to body tubes) and the tips of the wings where the laser cannon are attached. Allow sealer to dry completely and lightly sand all surfaces. Apply a second coat of sealer, let dry and sand. The balsa should now be smooth and free of grain lines. If necessary repeat sealing and sanding a third time to obtain a good surface finish.

CUT IN TWO

Part E:



Part D:



Part F:

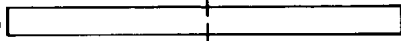

FULL SIZE VIEWS

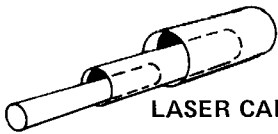

LASER CANNON—MAKE TWO

7 Locate the two launch lugs and the dowel shown in the illustration. Use the illustration as a guide to cut each of these parts into two equal lengths. Using the lower illustration as a guide, glue the parts together to make two laser cannon.

MAKE SPACERS FROM WASTE CARDSTOCK

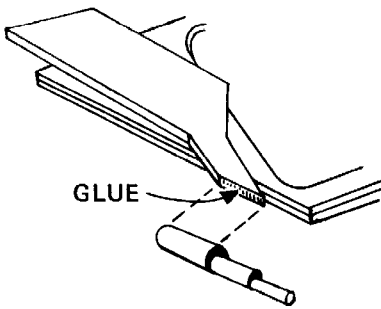

GLUE

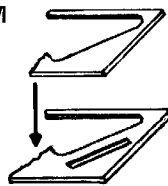

CANNON

WING

SPACERS

EVEN WITH REAR EDGE

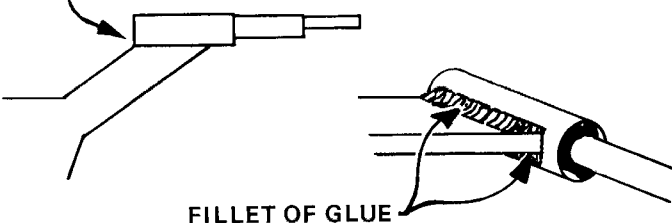

FILLET OF GLUE

8 Cut the cardstock sheet (from which guides were removed) in two. Place the cardstock, one piece on top of the other, on a flat surface. Lay a wing on top of these with the front inside edge extending out as shown. Apply glue to this edge and attach a cannon in the position shown. Allow to dry 10 minutes before moving. Repeat with remaining wing and cannon. After the glue has thoroughly dried, apply a small bead of glue to both sides of each joint. Smooth into an even fillet with your finger.

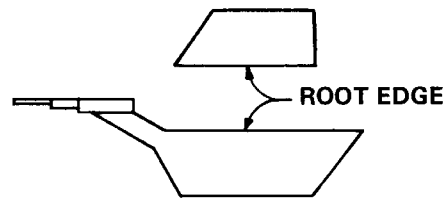

ROOT EDGE

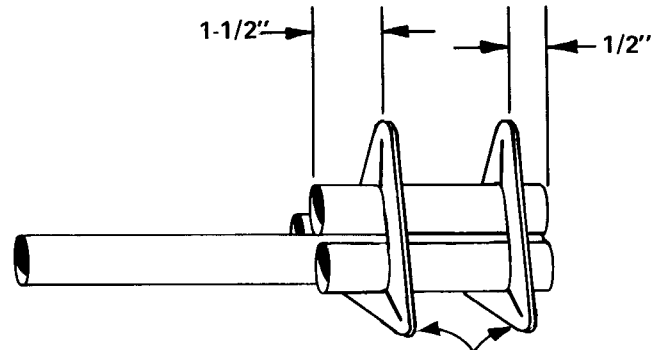

ALIGNMENT GUIDES

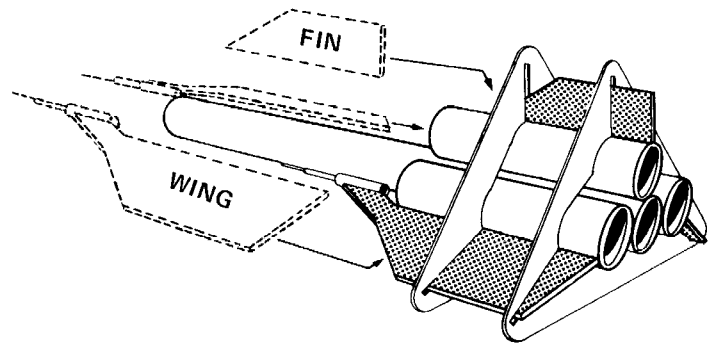

FIN

WING

9 Lightly sand the root (gluing) edge of the fin and each wing. Make sure these edges are square and true. Position the alignment guides on the fuselage as shown.

Apply a light film of glue to the root edge of the fin and each wing. Allow to dry for 3-4 minutes. Apply a second light film of glue to the fin root edge and slip it into the guide, holding the fin away from the body. Position the fin with its rear edge even with the rear of the body and press into place against the tube. Attach the wings in the same manner. Make sure you have not accidentally glued the alignment guides to the fin, wings or body, then set the assembly aside for 20 minutes before disturbing.

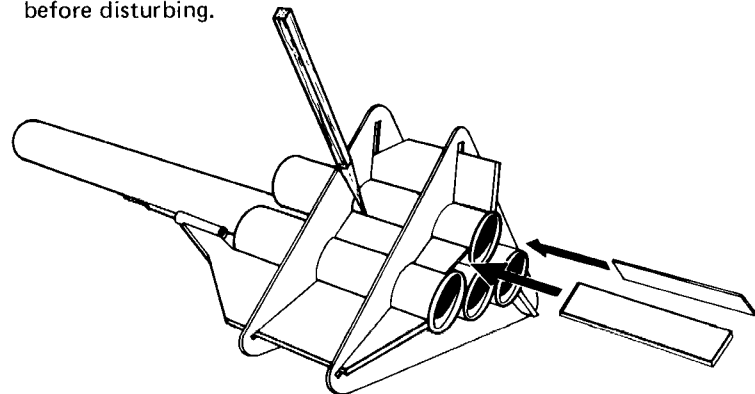

10 Locate the two cardboard strips that fit along sides of turbo tubes (previously removed from die-cut sheet). Slip these strips in place under the alignment guides as shown. Make sure rear edges of strips are flush with rear of tubes. Use the glue applicator stick to apply a very small amount of glue to the edges of the strips where they contact the tubes. Do not get any glue on the alignment guides.

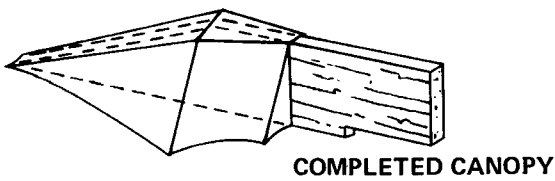

1
CUT OUT
CANOPY

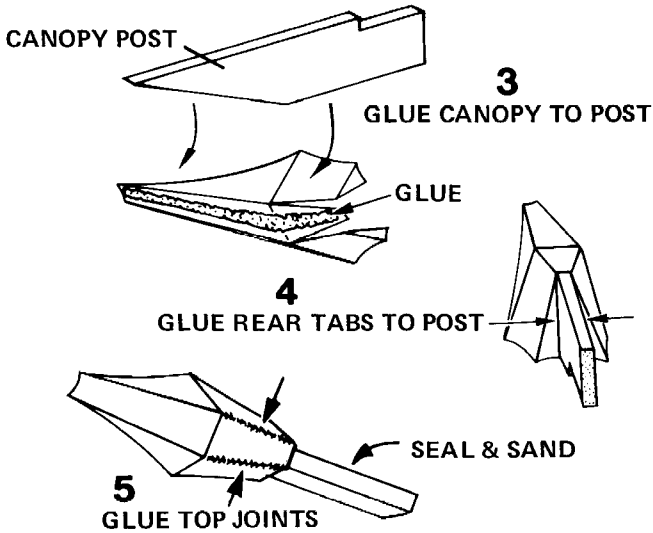
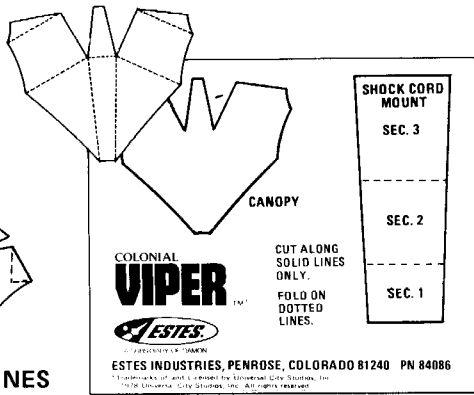

11 From the printed sheet (part M), carefully cut out the canopy along the solid lines. Using a straightedge and sharp hard-lead pencil, draw along dotted lines to facilitate folding. Fold the canopy inward along lines as shown. Locate the canopy post previously removed from the balsa sheet. Run a bead of glue along the underside of the canopy and attach post as shown. Make sure the post is centered in the canopy. Allow glue to dry, then glue the rear tabs to the sides of the post. Use the applicator stick to apply glue to these joints. Hold the tabs in place until the glue sets. Run a very light bead of glue along the seams between the sides and top of the canopy. Wipe away excess glue to form a smooth seam. When the glue has dried, seal and sand the exposed portion of the balsa post.

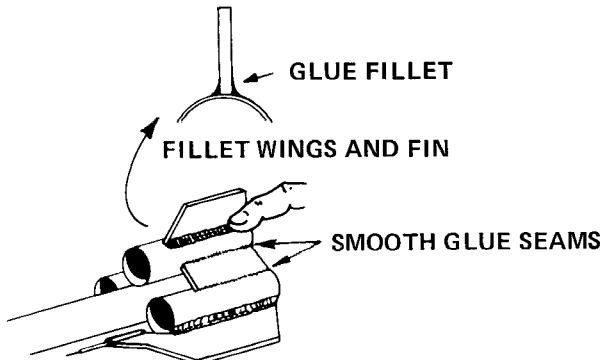

12 Remove the alignment guides from the body assembly. . . after the glue has thoroughly dried. Apply a light bead of glue to the joints between the side strips and the tubes. Wipe away excess glue, leaving smooth, even seams. Run a bead of glue along the root edges of the fin and wings. Use your finger to form the glue into smooth fillets.

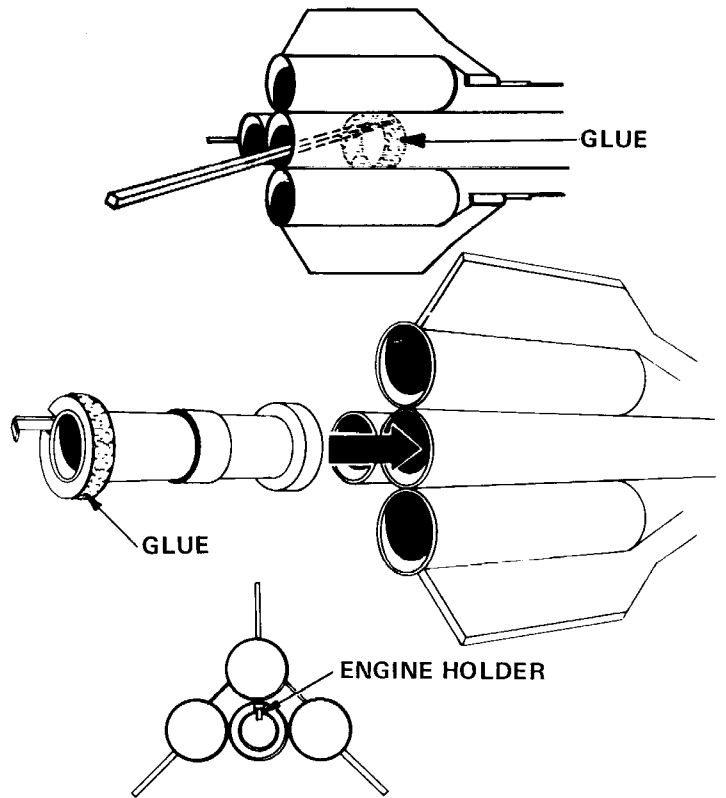

13 Assemble the engine mount to the body. !Using the applicator stick, apply a bead of glue around the inside of the body tube 2" from the rear end. Apply another bead of glue around the rear ring of the engine mount. Push the mount into the body with the engine holder pointing up. Push the mount in until it is flush with the end of the tube. Wipe away excess glue.

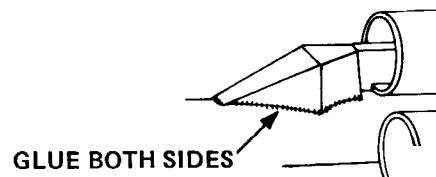
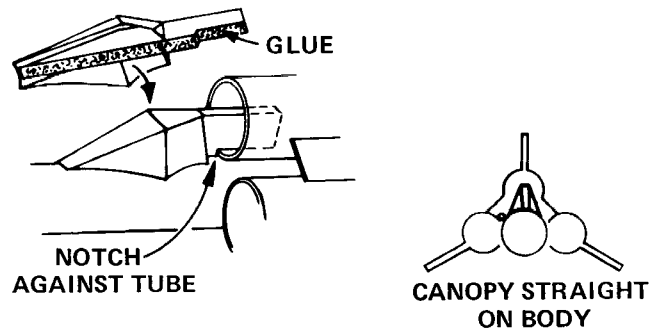

14 Attach the canopy to the body. Run a bead of glue along the bottom of the canopy post. Set the canopy in place on body tube with the notch in the post against the end of the top turbo tube. Sight down the assembly from the front to make sure the canopy is straight. Run a bead of glue along both sides of canopy where it joins the body. Wipe away excess glue, leaving a smooth seam.

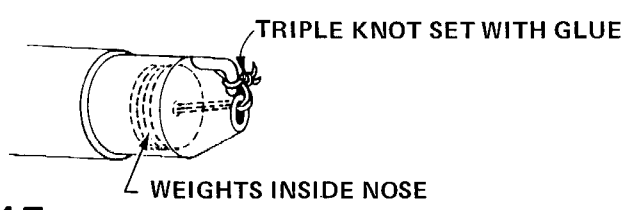
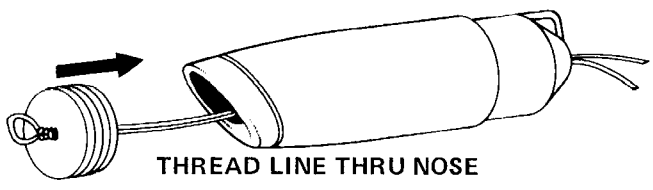
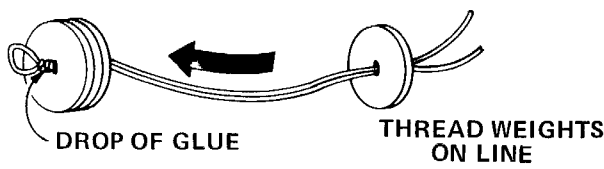
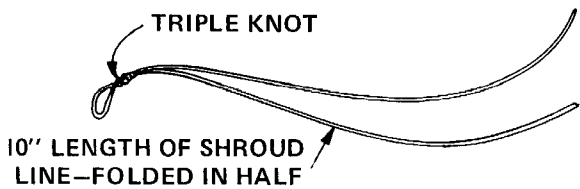
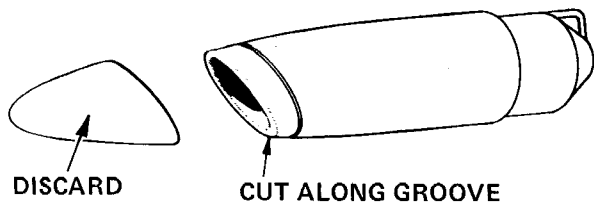

15 Locate the nose cone (part N), four weights (part O) and length of shroud line (part R). Carefully cut off the end of the nose cone along groove. Make several light cuts rather than one heavy one. Sand the end of the nose cone to round the outside edge of the opening. Cut a 10" length from the coil of shroud line. Fold the line in half and tie a triple knot in the folded end. Thread the four nose weights onto the line. Set the knot with a drop of glue. Thread the line through the nose cone from the front. Pull the line tight, securing the weights against the inside rear wall of the nose cone. Tie the line to the attachment ring and set the knot with a drop of glue. Cut off excess shroud line.

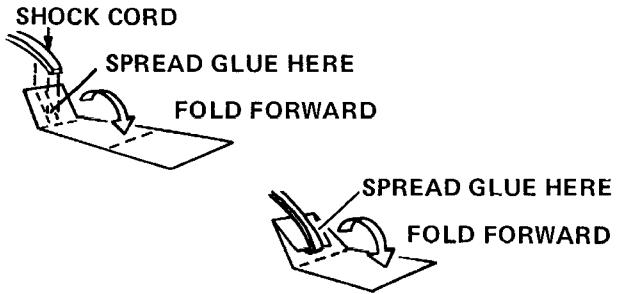

16 Cut the shock cord mount from the printed sheet (part M). Crease it on the dotted lines by folding. Spread glue on the first section (1) and lay the end of the shock cord (part P) into the glue. Fold over and apply glue to the back of the first section and the exposed part of section 2. Lay the shock cord as shown and fold over again. Clamp the unit together with your fingers until the glue sets.

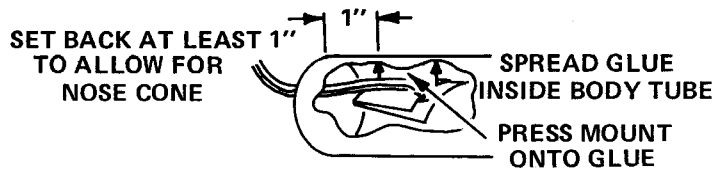

Apply glue to the inside of the front of the body tube to cover an area 1 inch to 2 inches from the end. The glued area should be the same size as the shock cord mount. Press the mount into the glue as shown. Hold it until the glue sets.

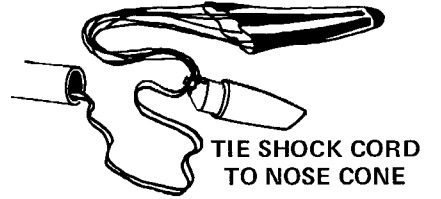
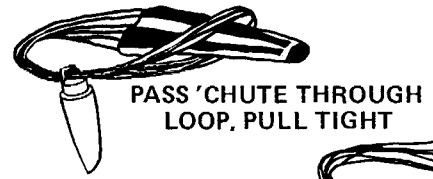

17 Locate the parachute (part Q), tape discs (part S) and the remaining length of shroud line (part R). Cut out the parachute along its edge lines. Cut the shroud line into three equal lengths. Attach the lines to the chute with tape discs as shown. Be sure the discs are pressed firmly against chute material. Pass the shroud lines through the ring at the rear of the nose cone. Pass the parachute through the loop ends and draw the lines tight against the ring. Set the knot with a drop of glue. Tie the free end of the shock cord to the ring. Fold the chute and insert, along with shock cord, into the body. Socket nose cone in place.

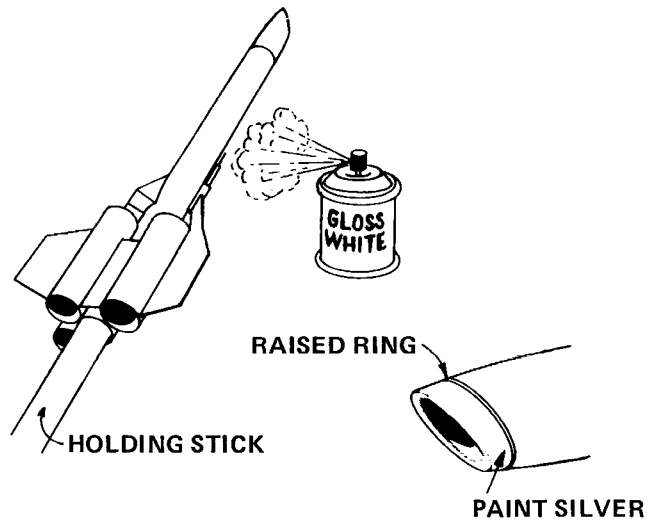

18 Locate a convenient sized piece of wood that can be fitted into the engine mount. This will serve as a holding stick while painting the model. Spray the model with two light coats of gloss white enamel, allowing 20 minutes between coats. When the paint has completely dried, brush paint the tip of the nose silver. You may wish to paint the inside of the turbo tubes black. If you do this, take care not to get black paint on the lasers, canopy or other outside portions of the body.

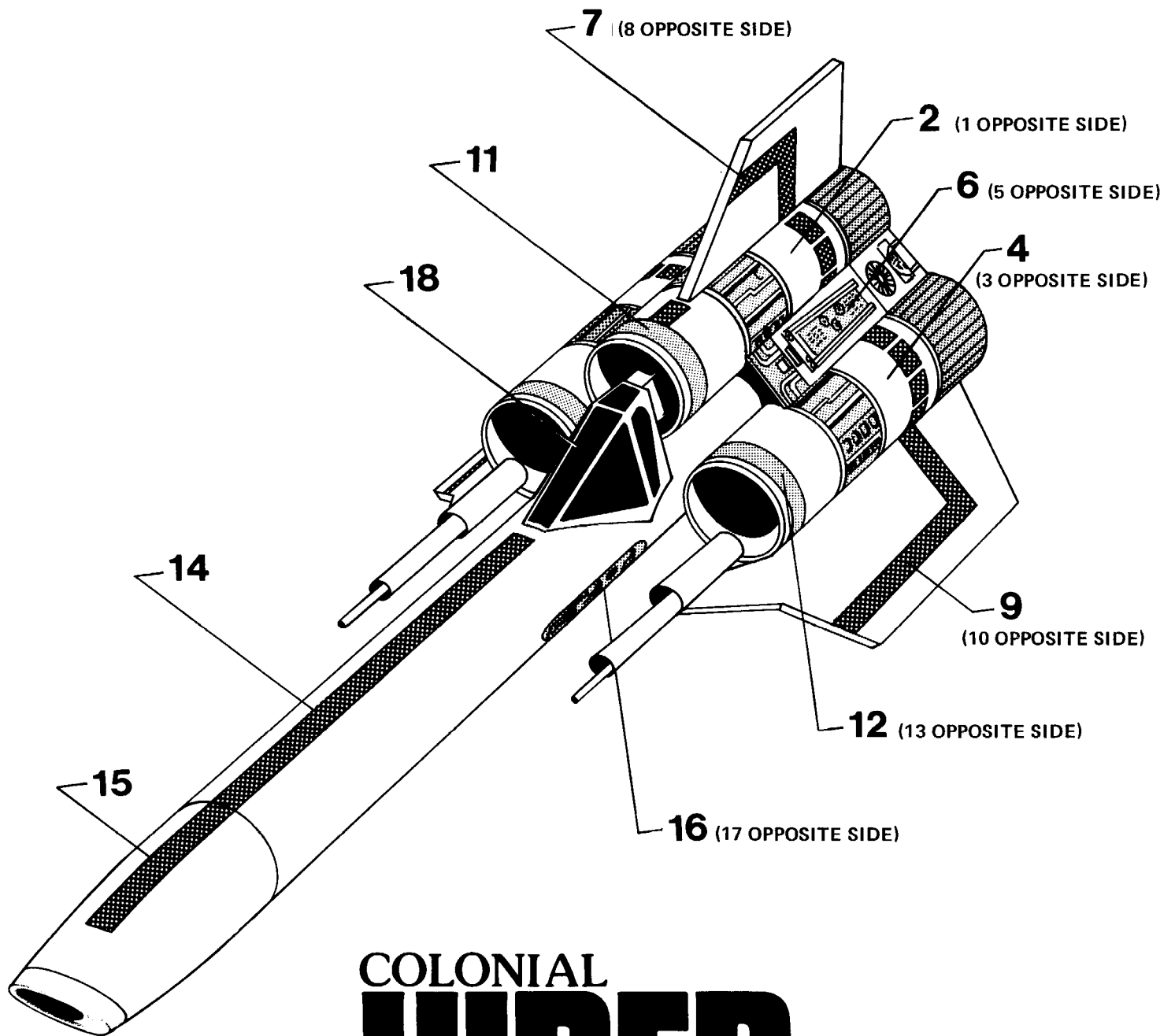

COLONIAL VIPER™

DECAL PLACEMENT

19 Locate the sheet of pressure sensitive stickers (part T). Study the illustration and the sheet before starting. All the stickers are numbered and some have a notation as to top edge. Apply the stickers, one at a time in numerical sequence, to the locations as shown. When you apply the sticker, lay it in place gently. If the location is not exactly right, lift the sticker

and re-apply. Once you are satisfied with the location, press the sticker firmly into place. Note that the front turbo rings (parts 12 & 13) are in two pieces. The portion indicated as "bottom", is applied to the underside of the turbo tube. The canopy window stickers are individual pieces and are more easily applied with small tweezers.

COUNTDOWN CHECKLIST

T-14 Pack four squares of loosely crumpled recovery wadding into body tube.

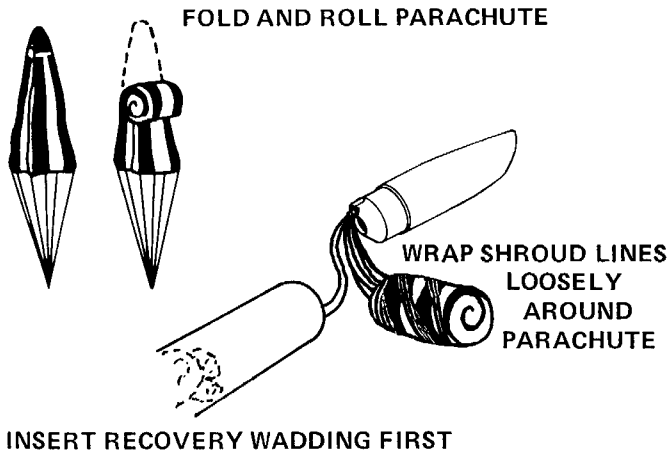

T-13 Fold the parachute into a triangular shape. Fold 'chute tightly as shown and wrap shroud lines around it. If 'chute is too large, unroll it and repack until it slides easily into rocket. A fit that is too tight may prevent parachute from ejecting properly.

NOTE: DO NOT pack parachute until you are actually ready to launch. For maximum parachute reliability, lightly dust the 'chute with ordinary talcum powder before each flight, especially in cold weather.

T-12 Pack shock cord neatly into rocket, then slide nose cone into place. Nose cone should separate easily from rocket body tube, but should not be extremely loose. If it is too tight, sand inside of body tube end and shoulder of nose cone with extra fine sandpaper.

If nose cone is too loose add a wrapping of transparent tape or masking tape to the shoulder of the nose cone.

T-11 Select an engine and install an igniter as directed in the engine instructions. Engines recommended for use with this rocket are B6-4 and C6-5. A B6-4 is recommended for the first flight.

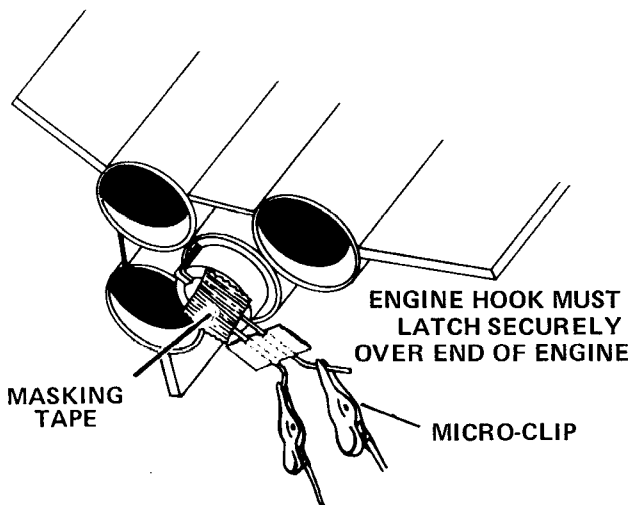

T-10 Insert engine into rocket. Engine hook must latch securely over end of engine.

T-9 Disarm the launch panel---remove safety key.

T-8 Place rocket on launch pad, making sure rocket slides freely on launch rod. Clean the micro-clips and attach them to the igniter leads.

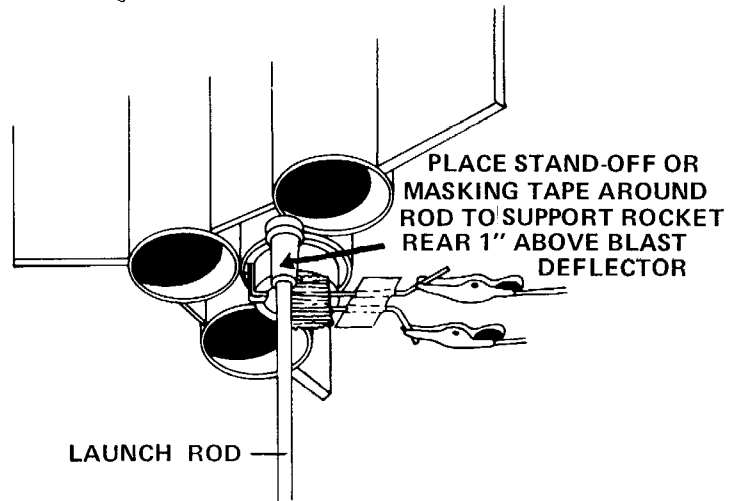

T-7 Clear the launch area, alert recovery crew and trackers. Check for low flying aircraft and unauthorized persons in the recovery area.

T-6 Arm the launch panel---insert safety key.

-5-4-3-2-1-LAUNCH!!

MISFIRE PROCEDURE

Occasionally the igniter will heat and burn in two without igniting the engine. This is almost always caused by a failure to install it correctly. Disarm the launch panel, remove the model, clean the igniter residue from the nozzle, and install a new igniter. Follow the launching procedure again.



Be sure to follow the *HIAA-NAR Model Rocketry Safety Code when carrying out your model rocket activities.
*HIAA-NAR - Hobby Industry Association of America
- National Association of Rocketry

ESTES INDUSTRIES
PENROSE, COLO. 81240 USA

3/32"

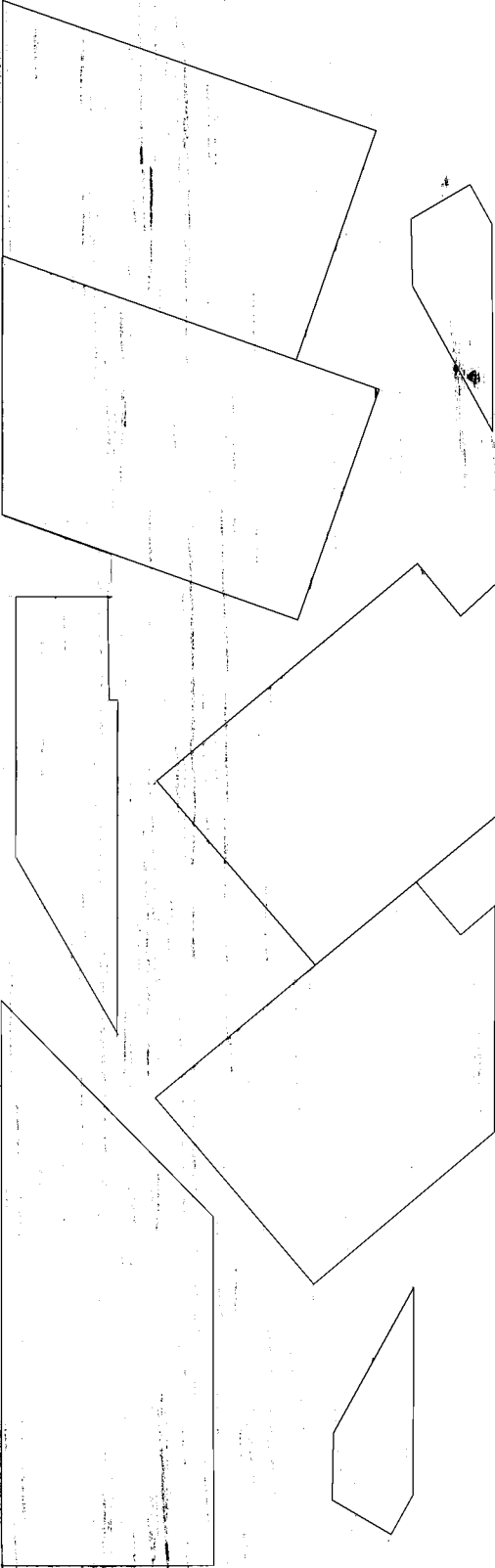

No. C303SR

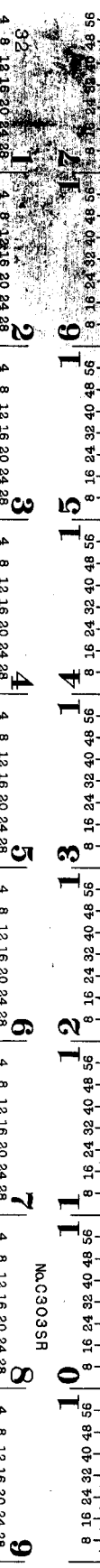
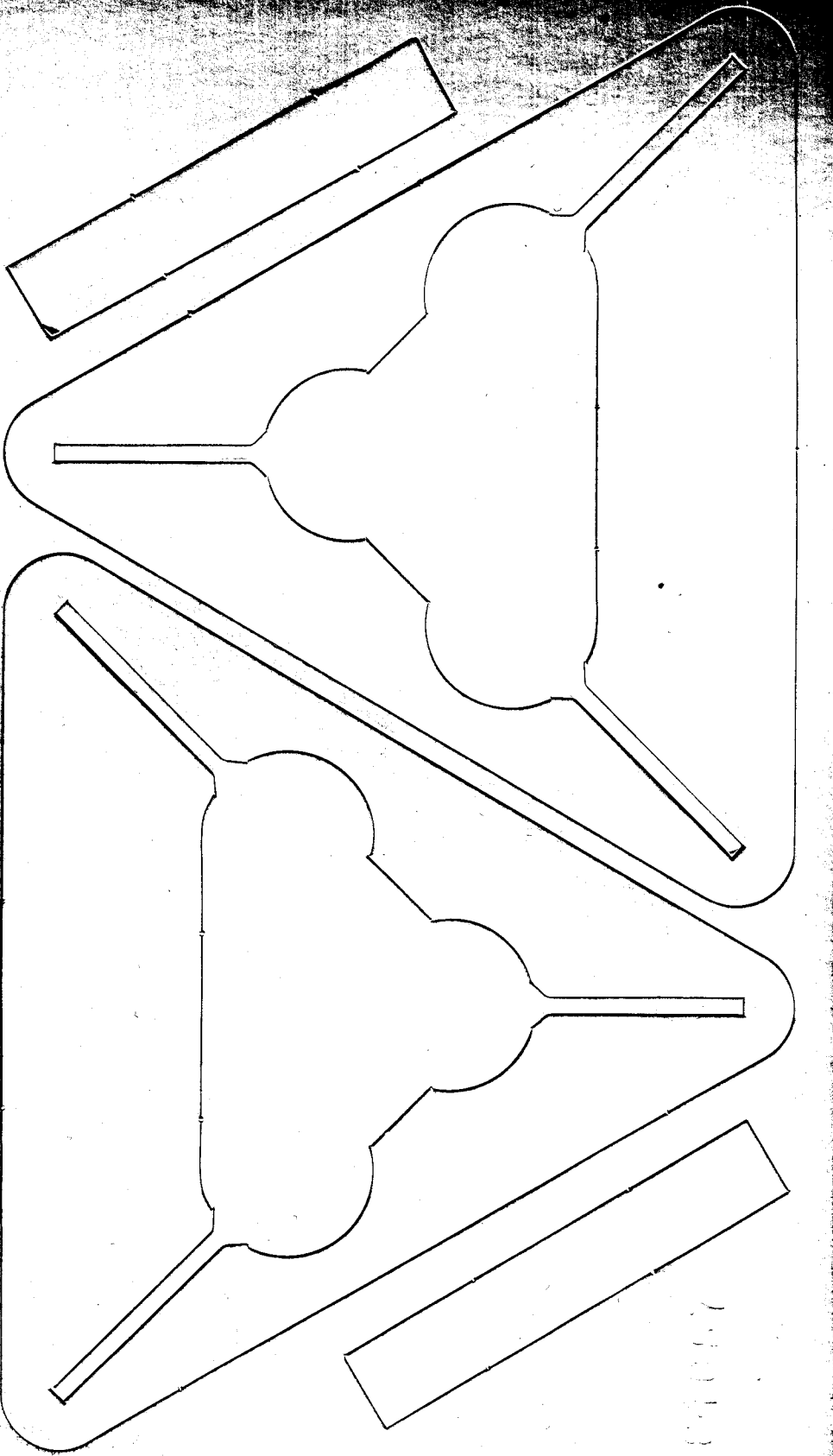

NO. C303SR

THE U.S. ATCO

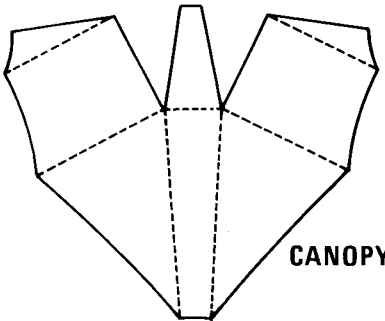

CANOPY

VIPER
STAR FIGHTER



A SUBSIDIARY OF DAMON

ESTES INDUSTRIES, PENROSE, COLORADO 81240 PN 84086

CUT ALONG
SOLID LINES
ONLY.

FOLD ON
DOTTED
LINES.

SHOCK CORD
MOUNT

SEC. 3

SEC. 2

SEC. 1



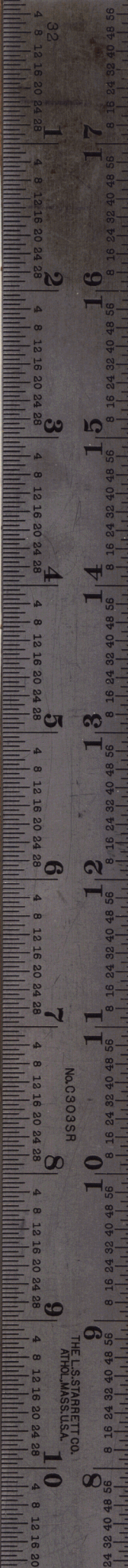

(14) FUSELAGE STRIPE

(15) NOSE STRIPE

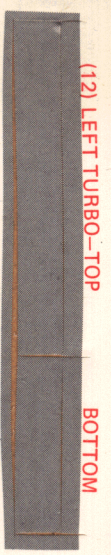

(12) LEFT TURBO-TOP

BOTTOM



(13) RIGHT TURBO-TOP

BOTTOM

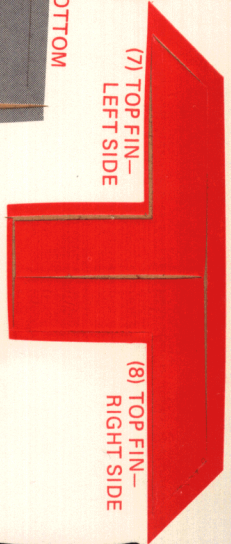

(7) TOP FIN-
LEFT SIDE

(8) TOP FIN-
RIGHT SIDE



(18) WINDOWS



(10) RIGHT WING



(11) TOP TURBO

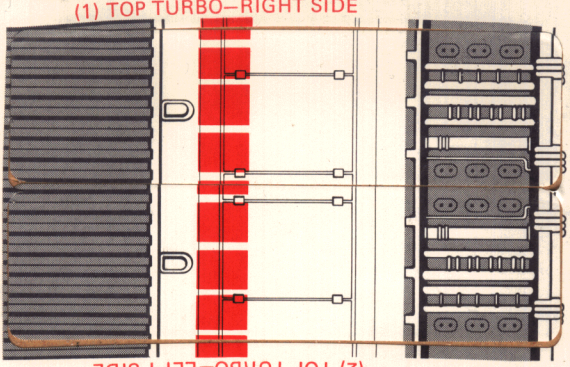

(1) TOP TURBO-RIGHT SIDE

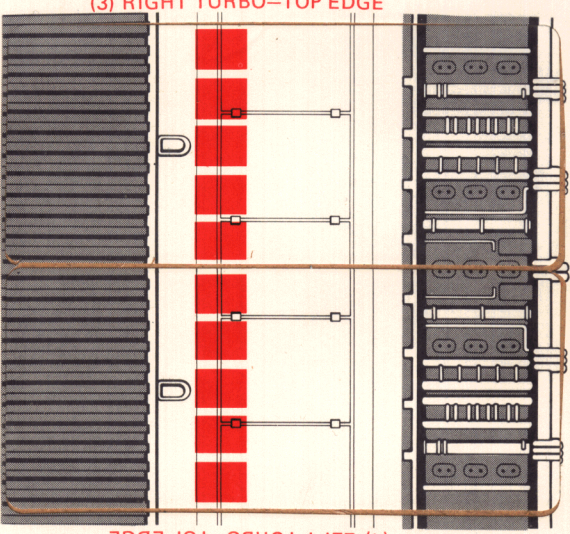

(2) TOP TURBO-LEFT SIDE

(3) RIGHT TURBO-TOP EDGE

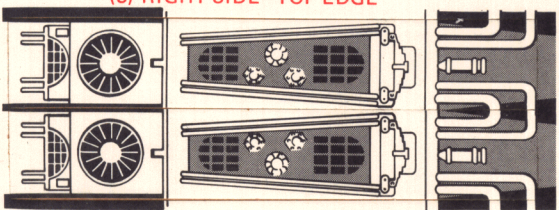

(4) LEFT TURBO-TOP EDGE

(5) RIGHT SIDE-TOP EDGE

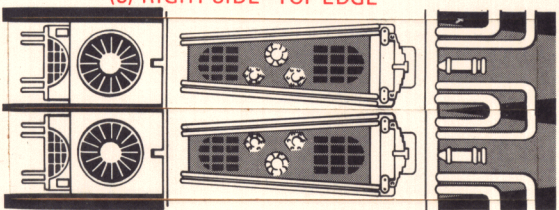

(6) LEFT SIDE-TOP EDGE

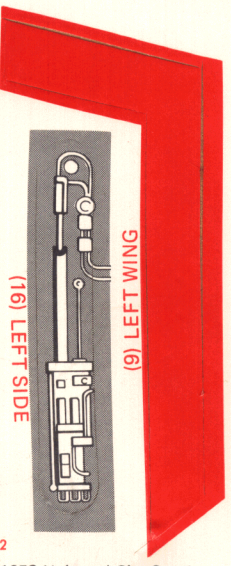

(9) LEFT WING

(16) LEFT SIDE

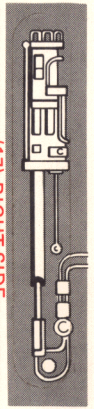

(17) RIGHT SIDE