



POLARIS

KIT NO. 1324
SKILL LEVEL 1

PARTS LIST

A	1	Main Body Tube (BT-50W)	30372
B	1	Payload Section Tube (type BT-50S)	30368
C	1	Die Cut Balsa Sheet (BF-L3)	32254
D	1	Plastic Nose Cone (PNC-50Y)	71009
E	1	Balsa Nose Block (NB-50)	70158
F	1	Launch Lug (LL-2B)	38178
G	1	Engine Mount Tube (BT-20J)	30326
H	1	Engine Hook (EH-2)	35025
I	1	Split Ring Adapter (AR-2050S)	80425
J	1	Adapter Ring (AR-2050)	30164
K	1	Mylar Ring (HR-20)	30168
L	1	Screw Eye (SE-2A)	38252
M	1	Parachute (PK-12A)	85564
N	1	Shock Cord (SC-1)	85730
O	1	Shroud Line Cord (SLT-72)	38237
P	6	Tape Discs (TD-3F)	38406
Q	1	Decal (KD-1324)	37503
R	1	Pattern Sheet	82630

IMPORTANT:

Read all instructions before beginning work on your model. Make sure you have all parts and materials. When you are thoroughly familiar with the assembly procedure, begin construction. Check off each step as you complete it. In each step, test-fit the parts together before applying any glue. If some part doesn't fit properly, sand lightly or build up as needed for precision assembly.

In addition to the parts included in this kit you will need scissors, a pencil, a metal-edged ruler, white glue, a sharp model knife (or a single edge razor blade), fine sandpaper, masking tape, sanding sealer, and paint.

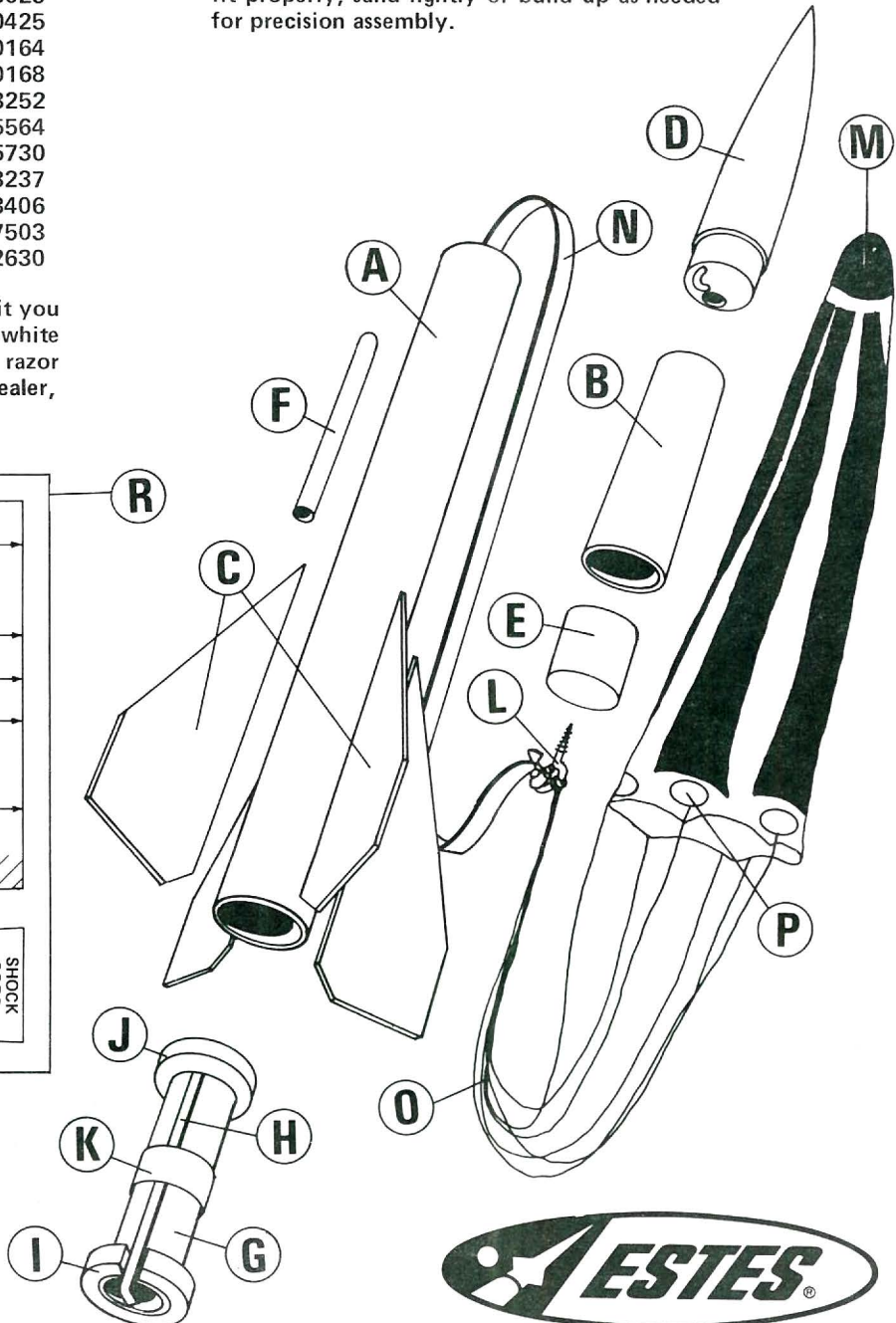
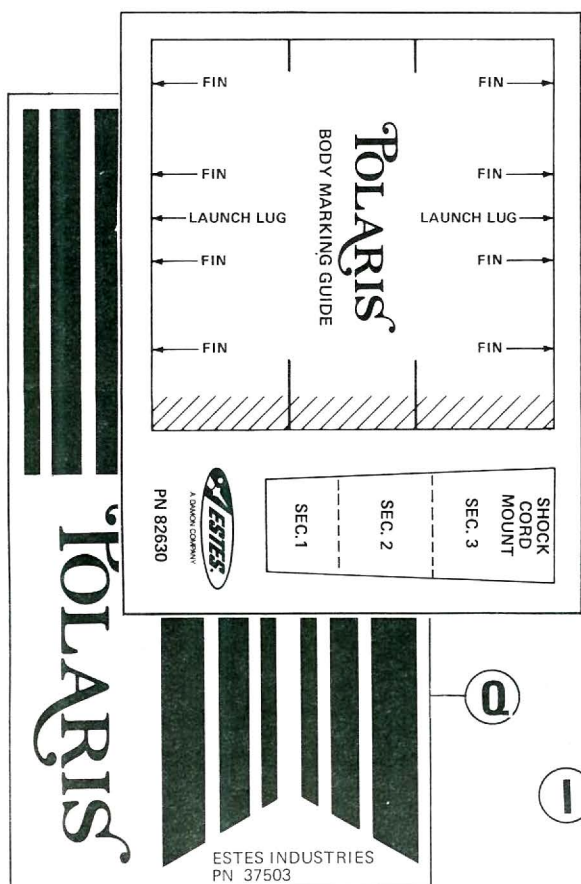

A DAMON COMPANY
ESTES INDUSTRIES
PENROSE, COLO. 81240 USA

ASSEMBLY INSTRUCTIONS

COMPLETED ENGINE MOUNT

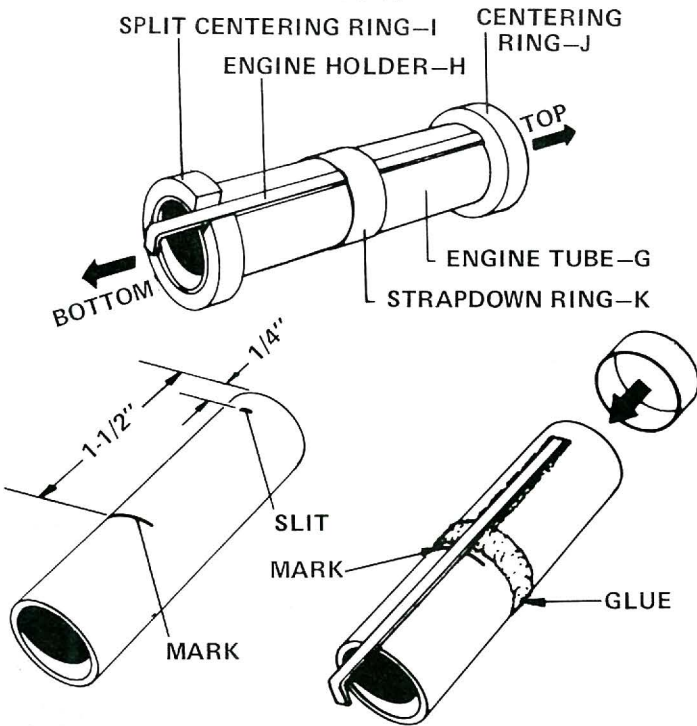

1 Locate the parts called out in the illustration above. Cut a 1/8" wide slit, 1/4" from the end of the tube and place a mark on the tube 1-1/2" from same end. Run a bead of glue from slit to mark. Place one end of engine holder in slit. Hold engine holder in place and run a bead of glue around tube above mark. Slide strapdown ring over top of tube and push down to mark. Glue centering ring to top and split ring to bottom of tube, flush with the ends.

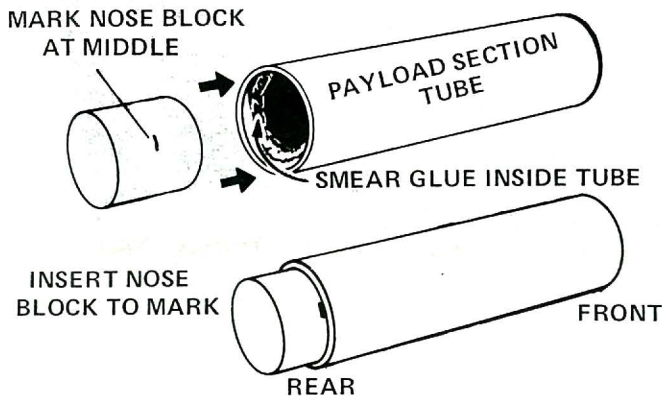

2 Mark the nose block (part E) half-way along its length. Apply a line of glue around the inside of the payload section tube (part B), about 1/8" in from one end. Slide the nose block into place in this end of the tube so the mark is even with the end of the tube.

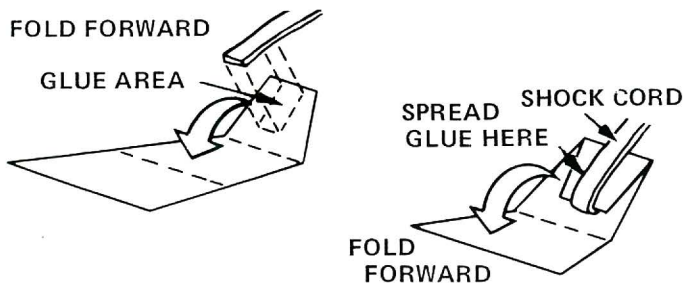

3 Cut out the shock cord mount from the pattern sheet. Crease it on the dotted lines by folding. Spread glue on the first section (1) and lay the end of the shock cord (part N) into the glue. Fold over and apply glue to the back of the first section and the exposed part of section 2. Lay the shock cord as shown and fold over again. Clamp the unit together with your fingers until the glue sets.

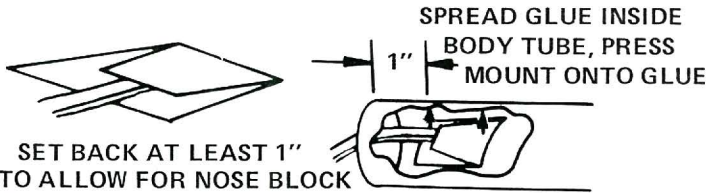

4 Apply glue to the back side of section 2 and the exposed part of section 3 of the shock cord mount. Hold the mount (wide end toward tube) as shown, and press it into place in the main body tube (part A). Make sure the front of the mount is at least 1" from the end of the tube. Hold the mount in place until the glue sets.

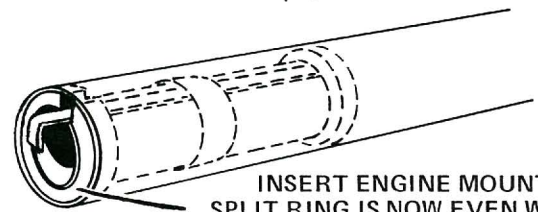
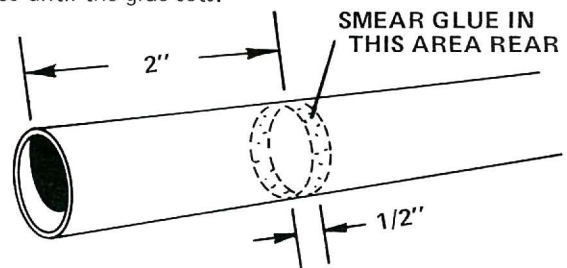

5 Smear glue around the inside of the rear end of the main body tube (the end away from the shock cord mount). The glue should cover an area about 2" to 2-1/2" from the end of the tube. Push the engine mount unit in right away--but be sure the mount is turned so the hook will stick out of the end of the tube! Push the engine mount in with one smooth motion until the ends of the tubes (and the split ring) are even.

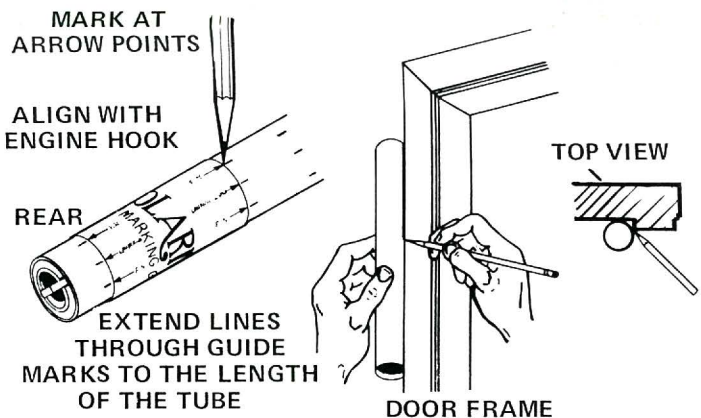

6 Cut out the body tube marking guide from the pattern sheet. Wrap it around the rear of the body so the launch lug marks are in line with the engine hook. Mark the tube at each arrow point, front and rear. Draw a straight line connecting each matching front and rear mark. (Use a door frame as a guide when drawing lines). Extend the lines to the middle of the tube.

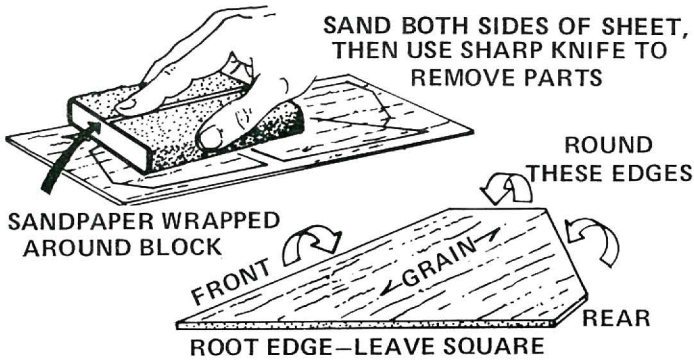

7 Fine-sand the balsa sheet (part C), then carefully remove the fins from the sheet. Free the edges with a sharp knife. Sand all edges except the root edge to a rounded shape. Make sure the root edge stays square.

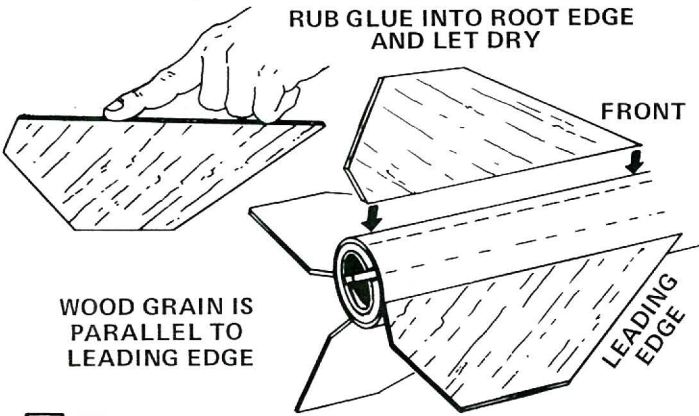

8 Rub a line of glue into the root edge of each fin and allow to dry. Glue the fins to the body on the fin alignment lines drawn in step 6. Refer to the illustration to be sure you position the fins correctly. Adjust the fins so they project straight away from the body tube. Do not set the rocket on its fins while the glue is wet.

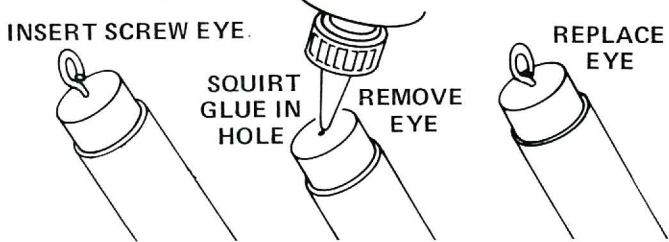

9 Insert the screw eye (part L) into the rear of the nose block. Remove the screw eye and squirt a small amount of glue into the hole. Re-insert the screw eye.

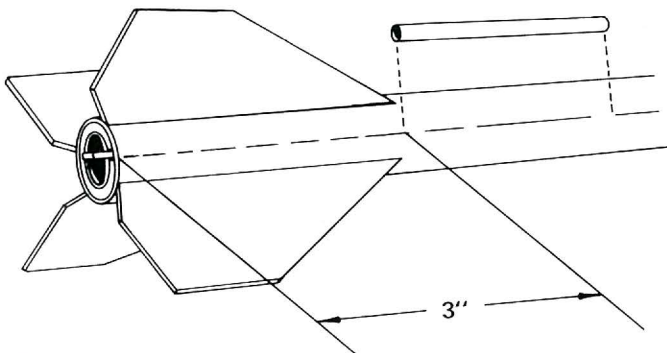

10 Glue the launch lug (part F) to the body on its line. The rear of the lug should be 3" from the rear of the body. Align the lug straight on the body.

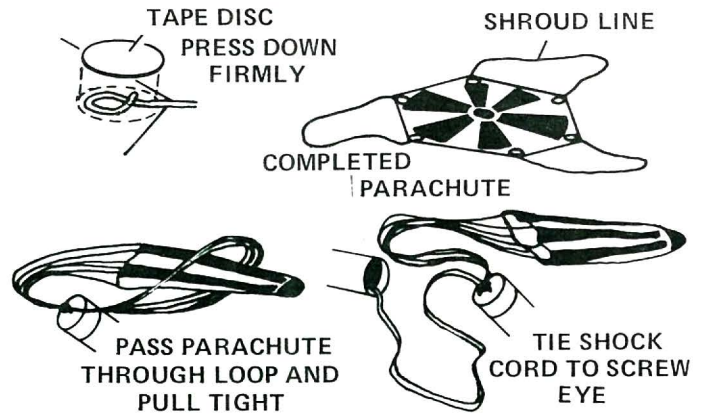

11 Cut out the parachute (part M) on its edge lines. Cut three 24" lengths of shroud line (part O). Attach line ends to the top of the parachute with tape discs (part P) as shown. Pass the shroud line loops through the screw eye on the payload section. Pass the parachute through the loop ends and pull the lines tight against the screw eye. Set the knot with a drop of glue. Tie the free end of the shock cord to the screw eye.

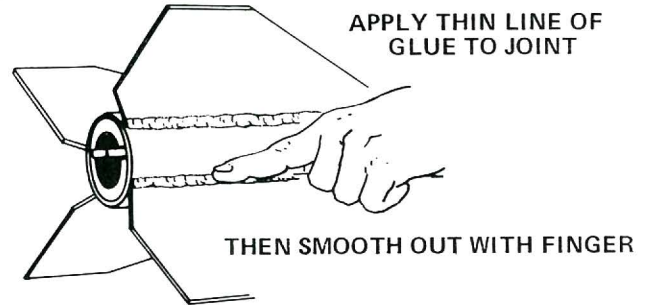

12 When the fin joints have dried, apply glue reinforcements to each joint. Holding the model level, apply a narrow line of glue to both sides of each fin joint. Smooth out the glue with your finger. Keep the model level until the glue dries.

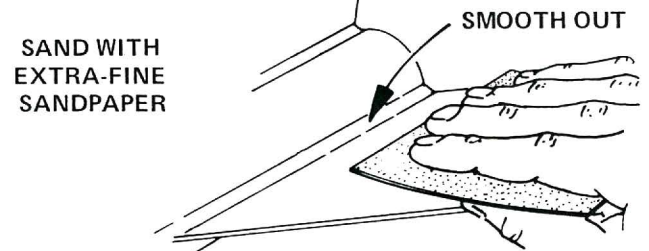
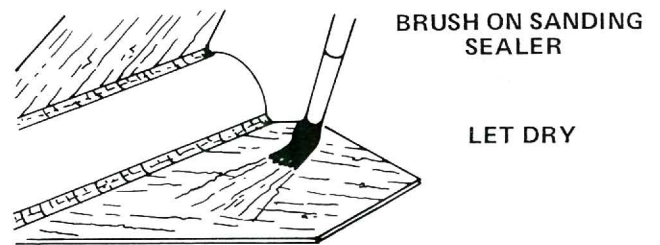

13 When all glue on the outside of the body is dry, prepare the fins for painting. Apply at least two coats of sanding sealer to the fins. Let dry and sand thoroughly between coats. Do this until the tiny holes in the wood are filled and everything looks and feels smooth. Install the nose cone (part D) in the front of the payload section. Paint the entire rocket gloss white. Let the paint dry overnight.

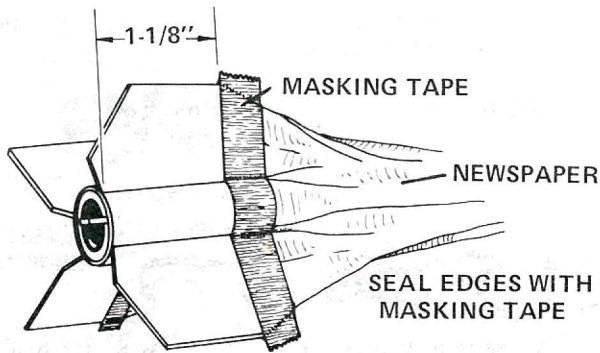

LEAVE AREAS TO BE PAINTED UNCOVERED

14 Study the photograph showing the finished (painted and decalled) model. Cover the main body 1-1/8 inch from the rear forward with masking tape and newspaper. Make sure the edges of the "masked" area are sealed down tightly with the masking tape. Paint the entire payload section with nose cone separately. Apply the gold paint in two or three very light layers. When paint surface is dry to the touch, remove the masking. Let the model dry overnight.



15 When all paint is completely dry, apply decals (part Q). Peel a decal section from the backing, dip it in mildly soapy water, and position it on the model. Blot excess water away. For best results, let the model dry overnight and apply a coat of clear spray to protect paint and decals.

COUNTDOWN CHECKLIST

Be sure to follow the HIAA-NAR* Model Rocketry Safety Code when carrying out your model rocketry activities.

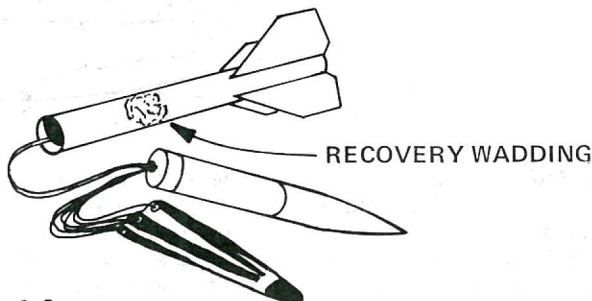

T-14 Pack four squares of loosely crumpled recovery wadding into the body tube.

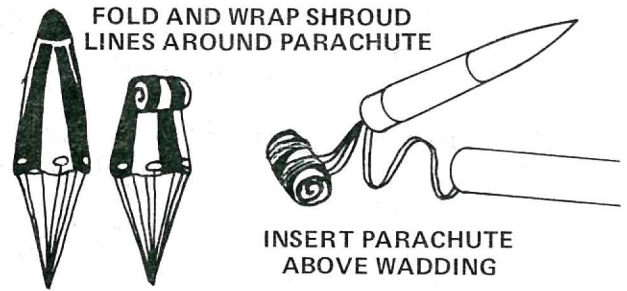

T-13 Fold the parachute into a triangular shape. Roll the 'chute tightly as shown and wrap the shroud lines around it. If 'chute is too large, unroll it and repack until it slides easily into rocket. A fit that is too tight may prevent the parachute from ejecting properly.

NOTE: DO NOT pack parachute until you are actually ready to launch. For maximum parachute reliability, lightly dust the 'chute with ordinary talcum powder before each flight, especially in cold weather.

T-12 Pack parachute, shroud lines, and shock cord neatly into the body tube. Slide payload section into place. Payload section should separate easily from rocket body tube, but should not be extremely loose. If it is too tight, sand inside of body tube and shoulder of nose block with extra-fine sandpaper. If fit is too loose, add a wrapping of transparent tape or masking tape to the shoulder of the nose block.

T-11 Select an engine and install an igniter as directed in the engine instructions. The engines recommended for use with this rocket are the 1/2A6-2, A8-3, B4-4, B6-4, and C6-5 made by Estes. Use an A8-3 engine for your first flight.

T-10 Insert engine into rocket engine mount. Engine hook must latch securely over end of engine.

T-9 Disarm the launch panel--remove safety key.

HOOK MUST LATCH SECURELY ON ENGINE

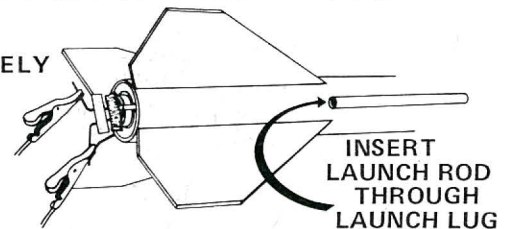

T-8 Slide launch rod through rocket launch lug and place rocket on launching pad. Make sure the rocket slides freely on the launch rod. Clean the micro-clips and attach them to the igniter leads. Arrange the clips so they do not touch each other or the metal blast deflector.

T-7 Clear the launch area, alert recovery crew and trackers. Check for low flying aircraft and unauthorized persons in the recovery area.

T-6 Arm the launch panel--insert safety key.

-5-4-3-2-1-LAUNCH!!

MISFIRE PROCEDURE

Occasionally the igniter will heat and burn into two pieces without igniting the engine. This is almost always caused by a failure to install it correctly. Disarm the launch panel, remove the model, clean the igniter residue from the nozzle, and install a new igniter. Follow the launching procedure again.

3/32"



300
DPI

1 2 3 4 5 6 7 8 9
0.1 0.2 0.3 0.4 0.5 0.6 0.7 0.8 0.9 1.0
1 2 3 4 5 6 7 8 9
1.0 2.0 3.0 4.0 5.0 6.0 7.0 8.0 9.0
10 11 12 13 14 15 16 17 18 19 20
21 22 23 24 25 26 27 28 29 30
31 32 33 34 35 36 37 38 39 40
41 42 43 44 45 46 47 48 49 50
51 52 53 54 55 56 57 58 59 60
61 62 63 64 65 66 67 68 69 70
71 72 73 74 75 76 77 78 79 80
81 82 83 84 85 86 87 88 89 90
91 92 93 94 95 96 97 98 99 100

SCALE



POLARIS

ESTES INDUSTRIES
PN 37503



32
 4 8 12 16 20 24 28
 1
 4 8 12 16 20 24 28
 2
 4 8 12 16 20 24 28
 3
 4 8 12 16 20 24 28
 4
 4 8 12 16 20 24 28
 5
 4 8 12 16 20 24 28
 6
 4 8 12 16 20 24 28
 7
 4 8 12 16 20 24 28
 8
 4 8 12 16 20 24 28
 9
 4 8 12 16 20 24 28
 10
 4 8 12 16 20 24 28
 11
 4 8 12 16 20 24 28
 12
 4 8 12 16 20 24 28
 13
 4 8 12 16 20 24 28
 14
 4 8 12 16 20 24 28
 15
 4 8 12 16 20 24 28
 16
 4 8 12 16 20 24 28
 17
 4 8 12 16 20 24 28
 18
 4 8 12 16 20 24 28
 19
 4 8 12 16 20 24 28
 20
 4 8 12 16 20 24 28
 21
 4 8 12 16 20 24 28
 22
 4 8 12 16 20 24 28
 23
 4 8 12 16 20 24 28
 24
 4 8 12 16 20 24 28
 25
 4 8 12 16 20 24 28
 26
 4 8 12 16 20 24 28
 27
 4 8 12 16 20 24 28
 28
 4 8 12 16 20 24 28
 29
 4 8 12 16 20 24 28
 30
 4 8 12 16 20 24 28
 31
 4 8 12 16 20 24 28
 32
 4 8 12 16 20 24 28

**300
 DPI**

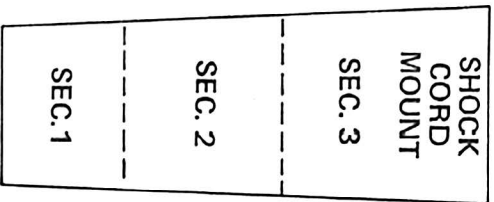
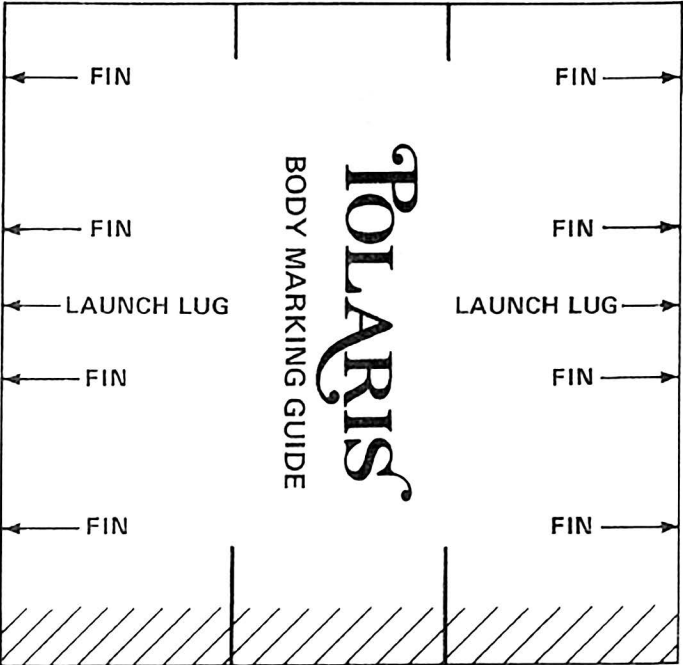

A DANAHAN COMPANY

PN 82630

PARTS LIST KIT NO. 1324 - Polaris

Quantity	Description	Type	Number	Detail1	Detail2	Detail3	Detail4	Comment
1	PAPER BODY TUBE	BT-50W	30372	9.5" long	0.950" ID	0.976" OD	0.013" wall	Glassine
1	PAPER BODY TUBE	BT-50S	30368	4" long	0.950" ID	0.976" OD	0.013" wall	Glassine
1	BALSA FIN STOCK	BFS-30	*3168	3" wide	9" long	3/32" thick	0.09375	Scan
1	PLASTIC NOSE CONE	PNC-50Y	71009	4.35" long	.974" dia.	.6" shoulder	BT-50 - Ogive	Blow Molded
1	BALSA NOSE BLOCK	NB-50	70158	1.0" long	0.950" dia.			BT-50
1	LAUNCH LUG	LL-2B	38178	5/32" ID	1/8" rod	2-3/8" long		Mylar
1	PAPER BODY TUBE	BT-20J	30326	2.75" long	0.710" ID	0.736" OD	0.013" wall	Glassine
1	ENGINE HOLDER	EH-2	35025	2.8" long	.100" wide	.025" thick		Reg. & D
1	SPLIT ADAPTER RING	AR-2050S	80425	1/4" long	.737" ID	.949" OD	0.106" wall	Green
1	CENTERING RINGS	AR-2050	30164	0.25" long	0.737" ID	0.949" OD	0.106" wall	Green
1	MYLAR RETAINER RIN	HR-20	30168	0.3" long	0.74" ID	0.76" OD	0.01" wall	BT-20
1	Screw Eye (Small)	SE-2A	38252	3/4" long				
1	Parachute	PK-12	85564	12" dia.				
1	Shock Cord	SC-1	85730	18" long	1/8" wide			Rubber
1	Shroud Line	SLT-72	38237	72"				
1	Tape Disc	TD-3F	38406	1/2" dia.				6x
1	Decal	KD-1324	37503	4" wide	7" long	Blue	Waterslide	Scan
1	Pattern Sheet	SP-1324	82630	4" wide	5.5" long	Cardstock		Scan

* Die Cut Balsa Sheet (BF-L3) Part #32254 (Also used in the coldpower Marauder #1103)



IMAGES BY
Gary Fortan



Recommended for Ages 10 to Adult. Adult Supervision Suggested for Those Under 12 Years of Age When Flying Model Rockets.

A SUBSIDIARY OF DAMON

1 MODEL KIT
Paint and Glue not included.
1 MODÈLE RÉDUIT
Peinture et Colle non comprises.

Flying Model Rocket

\$4.00

NEW! POLARIS



- Sounding Rocket Styling
- Payload Compartment
- Easy-to-apply Decal
- Plastic Nose Cone
- Die-Cut Fins
- 12" Parachute Recovery

SKILL LEVEL

1—Beginner 2—Intermediate 3—Craftsman 4—Advanced 5—Expert

SPECIFICATIONS

Length 18" (45.7 cm)
Body Dia. 0.976" (24.8mm)

Weight 1.3 oz. (37 g)
12" Parachute Recovery

RECOMMENDED ENGINES

1/2A6-2 A8-3 B4-4 B6-4 C6-5
Use A8-3 for first flights.

This is a hobby kit requiring assembly. Launch system, engines, glue, and finishing supplies are not included.

1324



ESTES INDUSTRIES
PENROSE, COLO. 81240 USA



PLEASE READ AND BECOME FAMILIAR WITH THE MODEL ROCKETRY SAFETY CODE ON THE REVERSE SIDE OF THIS CARD. PLEASE SIGN WHERE INDICATED AND KEEP THIS CODE WITH YOU DURING ALL YOUR MODEL ROCKETRY ACTIVITIES.

CAUTION-WARNING: For your safety DO NOT alter, dismantle, or unwrap model rocket engines or their ingredients in any way. Soak unwanted engines in water to destroy.

VERY IMPORTANT!

ATTENTION ESTES ROCKETEERS
Would you like to do your teacher a favor (and do a good turn for yourself at the same time)? Send us your science teacher's name and address, and we'll send him a free catalog and a teacher's guide. This guide explains ways in which model rocketry can make the science class more fun. It shows your teacher how to provide exciting "space missions" in which you and your friends learn how the big rockets operate while you are building and launching your own model rockets. Simply include your teacher's name and school address, and your own name and address on the back of this coupon. Mail it today!

BLAST-OFF!!

Join the **ESTES aerospace CLUB** and become a member of the most exciting rocket club on earth.

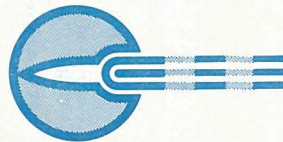

Membership includes Viper rocket kit, ID card, membership certificate, iron-on emblem, decal sheet, range box stickers, EAC stationary, Technical Manual, subscription to Model Rocket News, EAC Product Bulletin, and a variety of exclusive club services.

Lift-off For Fun!
Join Today!!

Check the appropriate space on your Rocketeer Registration/Catalog Request coupon for a free membership brochure and application.

NEW! POLARIS



- Sounding Rocket Styling
- Payload Compartment
- Easy-to-apply Decal
- Plastic Nose Cone
- Die-Cut Fins
- 12" Parachute Recovery

SKILL LEVEL

1—Beginner 2—Intermediate 3—Craftsman 4—Advanced 5—Expert

SPECIFICATIONS

Length 18" (45.7 cm)
Body Dia. 0.976" (24.8mm)

Weight 1.3 oz. (37 g)
12" Parachute Recovery

RECOMMENDED ENGINES

1/2A6-2 A8-3 B4-4 B6-4 C6-5
Use A8-3 for first flights.

This is a hobby kit requiring assembly. Launch system, engines, glue, and finishing supplies are not included.



1324



A DAMON COMPANY

ESTES INDUSTRIES
PENROSE, COLO. 81240 USA